



BIJOU

Bijou

(Formally known as S-Pod 4)

- 28' x 12'
- 1 Bedroom
- Sleeps 2-4

Feature List

Exterior

- Fusion galvanised chassis with finish warrantied for ten years
- Bonded sandwich exterior wall construction
- Coated steel pantile roof
- Distinctive folded steel bargeboards with lighting
- PVC gutters and down pipes
- Low energy exterior wall lights
- Contemporary one-piece sloping roof with overhang over deck area
- Fully glazed front sliding door
- Black with Yellow Stone highlights CanExcel cladding
- Anthracite uPVC windows with push-button security locks

Insulation

- Thermaglas uPVC double glazing
- Excellent thermal performance:
 - 60mm insulation in walls
 - 100mm insulation in roof
 - 80mm insulation in floor
 - Lagged underfloor pipes

Interior

- Open plan lounge and kitchen
- Hardwearing vinyl flooring in kitchenette, hallway and bathroom
- Luxury carpet with underlay in bedroom
- Low energy LED lighting throughout
- USB (A&C) sockets throughout

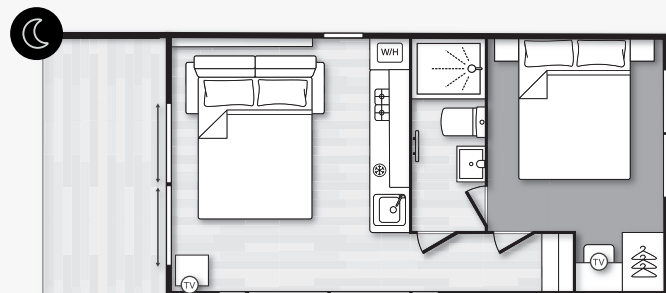
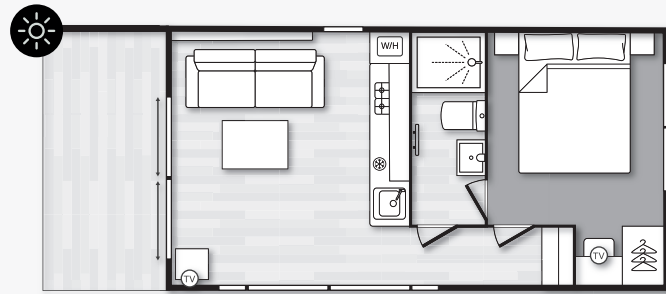

NUAGE

Nuage

(Formally known as S-Pod 6 Escape)

- 30' x 12'
- 2 Bedrooms
- Sleeps 4-6

Feature List

Exterior

- Fusion galvanised chassis with finish warrantied for ten years
- Bonded sandwich exterior wall construction
- Coated steel pantile roof
- Distinctive folded steel bargeboards with lighting
- PVC gutters and down pipes
- Low energy canopy downlights
- High peaked style roof with vaulted ceiling
- Fully glazed front sliding door
- Black with Yellow Stone highlights CanExcel cladding
- Anthracite uPVC windows with push-button security locks
- Integrated veranda with decking and side shutters

Insulation

- Thermaglas uPVC double glazing
- Excellent thermal performance:
 - 60mm insulation in walls
 - 100mm insulation in roof
 - 80mm insulation in floor
 - Lagged underfloor pipes

Interior

- Vaulted internal height 3.05m/10ft
- Open plan lounge and kitchen
- Hardwearing vinyl flooring throughout

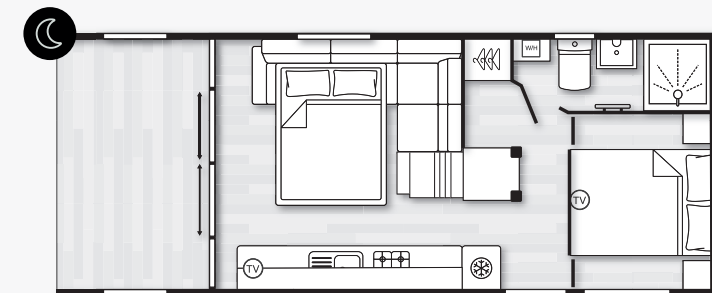
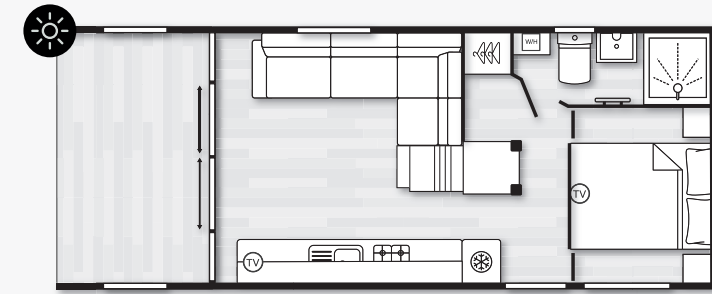

- Low energy LED lighting throughout
- USB (A&C) sockets throughout

Hallway

- Concealed storage area with single wardrobe, separate hanging rail and additional storage
- Coat hooks
- Under stair occasion seat with scatter cushion
- Bedroom partition with two sliding doors and large full-length mirror

Kitchenette & Lounge

- Glass fronted oven and grill with electronic ignition
- Flush fitted hob extractor
- Four-burner gas hob with electronic ignition
- Integrated appliances (under counter fridge & microwave oven)
- Black cast resin sink and drainer with black tap
- Marble effect worktops with glass splashback
- Fixed L-shaped sofa with scatter cushions and fold out bed
- Coffee table with dining table pop-up element
- Wall mounted TV point
- Ladder stars to upstairs bedroom
- Black out curtain and pelmet to front aspect sliding door
- Framed pictures and mirror

Options

- Acadia Green CanExcel cladding with Anthracite window frames
- Bluetooth audio connection to lounge ceiling speakers
- Integrated dishwasher
- Shaver socket
- Smart Command System

Main Bedroom

- King size lift-up bed with storage
- Duvalay Aurora mattress
- Padded headboard
- Background and reading lights
- Wall mounted TV point

Upper Bunk Bedroom

- Twin beds with bolster divide
- Duvalay mattresses
- Padded headboards
- Open bunk storage area
- Roof window with blind

Washroom

- Shower cubicle with thermostatic shower
- Dual flush WC
- Towel radiator
- LED illuminated vanity mirror with infrared sensor and demisting pad
- Tall boiler cupboard
- Extractor fan

S-Pod Specifications

	Sleeps	Double Bed	High Level Bunk Singles	Sofa Bed
Bijou	4	2.02m x 1.53m (6'8" x 5'0")	N/A	1.80m x 1.12m (5'11" x 3'8")
Nuage	6	1.91m x 1.53m (6'3" x 5'0")	1.83m x 0.75m (6'0" x 2'6")	1.80m x 1.12m (5'11" x 3'8")

	L1	L2	L3	L4	W1	W2	H1
Bijou	9.58m (31'5")	8.58m (28'2")	8.58m (28'2")	7.10m (23'3")	3.90m (12'10")	3.75m (12'4")	3.59m (11'9")
Nuage	10.19m (33'5")	9.49m (31'1")	9.19m (30'2")	7.08m (23'3")	4.04m (13'3")	3.75m (12'4")	4.18m (13'8")

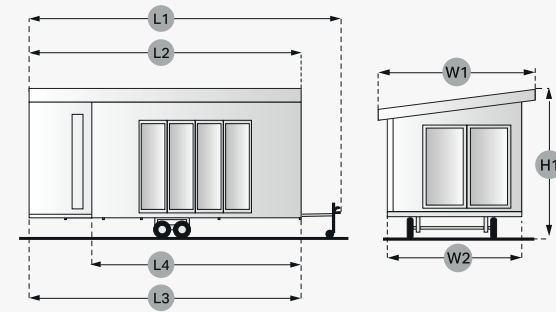

Bijou

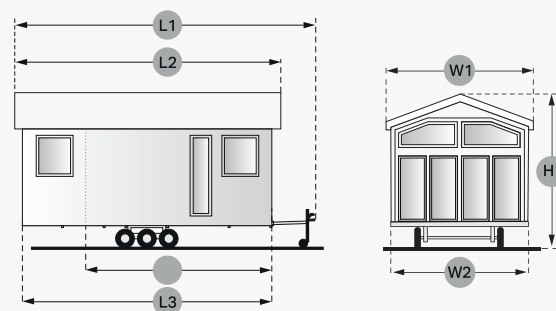

Nuage



ALIZEE

A compact pod with a big presence. Boutique inspired in design, it features an open plan living space with a king size bed at its heart, paired with a sleek kitchenette and integrated dining area. Every element is curated to deliver a high end, hotel style experience within a compact footprint.

20' x 11'
 1 Bedroom
 Sleeps 2

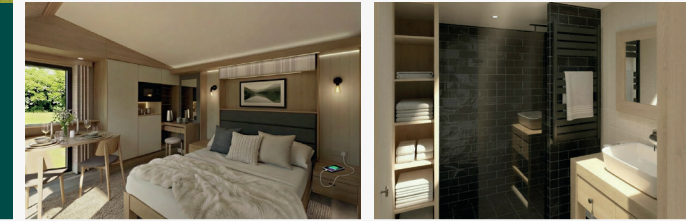

RUISSEAU

A bold twin unit design that redefines pod living. A central open plan lounge and kitchenette is paired with two separate bedrooms. Outside, a private patio with hot tub ready infrastructure creates a premium, experience led stay guests will pay more for.

28' x 20'
 2 Bedrooms
 Sleeps 4-6



DISCOVER OUR

S-Pod

2026 COLLECTION

swiftholidayhomes.co.uk

This brochure does not constitute an offer by Swift Group Limited (Swift). Swift reserves the right to alter specifications and prices at any time as materials and conditions demand. Distributors and dealers sell Swift products on their own account and not as agents of Swift. Accordingly, they have no authority to bind Swift or to make any representation or undertaking whatsoever on behalf of Swift. Please note, within this brochure, concept imagery may be used and therefore final specifications may be subject to change. Please confirm with your supplying dealer. All props are for photographic purposes only and are not included in the specification. Models shown may be fitted with optional extras. Issued May 2026.