



SWIFT
CREATING SMILES FOR LIFE

Love
S-Pod 6

love life

LOVE SWIFT



S-POD 6 RANGE

For ingenious compact living space, modern style and exquisite luxury, discover the S-Pod 6. Capable of comfortably sleeping 6 people thanks to a cleverly designed raised bunk

area, this innovative holiday unit fuses an open plan feel with an efficient footprint.

For valuable additional living space outside, choose the S-Pod 6 Escape with an integrated veranda.

Now comes with sliding doors





• Large sofa with foldout occasional bed and scatter cushions

• Spacious shower room with heated towel radiator and fixed water heater in dedicated cupboard

FEATURES AS STANDARD



Galvanised Chassis



Double Glazing



Hob



Fridge



Microwave



TV Point



Wardrobe



Sofa Bed



Sliding Entrance Doors

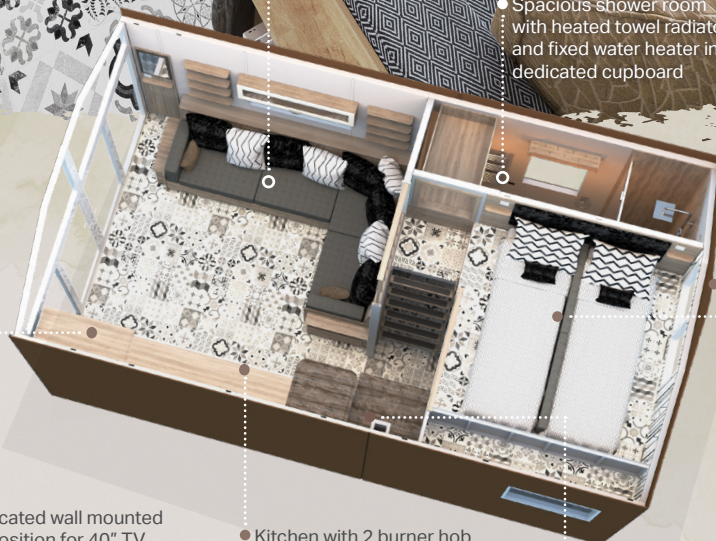

• Dedicated wall mounted TV position for 40" TV

• Kitchen with 2 burner hob (optional full oven, 4 burner hob and grill), microwave and domestic style rectangular sink bowl

• Dining area with pull down bed below bunk area

• Twin or double bed accessed via ladder

• Full height single wardrobe and dressing area with mirror



Spacious shower room



Comfortable dining area



Airy open plan living



Pull down bed in rear seating area



Twin beds made up as double on upper bunk area

FLOORPLANS

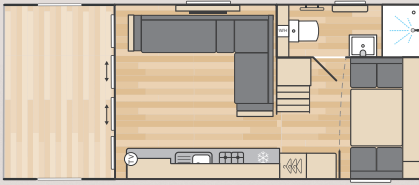

S-POD 6 ESCAPE - day 28' x 12' - 6 berth

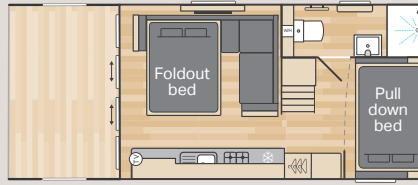

S-POD 6 ESCAPE - night 28' x 12' - 6 berth



S-POD 6 ESCAPE - bunk area 28' x 12' - 6 berth

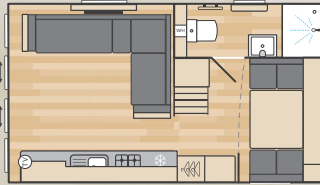

S-POD 6 - day 21' x 12' - 6 berth

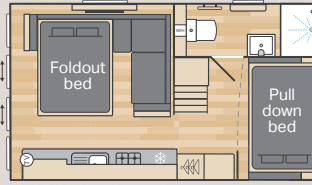

S-POD 6 - night 21' x 12' - 6 berth



S-POD 6 - bunk area 21' x 12' - 6 berth

BED SIZES

Model size	Bedrooms	'L' Sofa Foldout	Dinette Pull Down Double	Bunk Area Twins or Double
21' x 12'	2	190cm x 145cm (6'2" x 4'8")	200cm x 140cm (6'7" x 4'7")	183cm x 75cm (6'0" x 2'6") 183cm x 150cm (6'0" x 4'11")
28' x 12'	2	190cm x 145cm (6'2" x 4'8")	200cm x 140cm (6'7" x 4'7")	183cm x 75cm (6'0" x 2'6") 183cm x 150cm (6'0" x 4'11")



S-POD 6 RANGE

FEATURES

S-POD 6 ESCAPE

- Integrated veranda with side shutters for light and ventilation, offering an outside space to the front of the S-Pod

EXTERIOR

- Galvanised chassis with finish warranted for 10 years
- Coated steel pantile roof
- Fully glazed front with frosted glass feature panelling and sliding opening door
- CanExel high density wood composite cladding with durable realistic woodgrain texture in 'Cliffside'
- PVC gutters and downpipes
- Bonded 'sandwich' exterior wall construction for greater strength
- Exclusive high peaked style roof with vaulted ceiling
- Distinctive folded steel bargeboards with LED downlights
- Contemporary LED canopy downlights

INSULATION

- Thermaglas uPVC double glazed windows
- 60mm bonded walls for increased thermal efficiency
- Lagged underfloor pipes

INTERIOR & LIVING AREA

- Internal height 3.05m/10ft
- Open plan lounge and kitchen
- 'Nebraska Oak' woodgrain with 'Jackson Pine' contrast
- Large fixed 'L' shape sofa with extra wide foldout bed and scatter cushions
- Large under-sofa storage space
- Hard wearing vinyl floor in 'Almeria'
- White switches and sockets with dedicated USB points

- Dedicated wall mounted TV position for 40" TV
- Framed mirror with shelf and coat hooks
- Stylish feature pendant lights with Edison bulbs
- Curtains to front aspect and rear windows
- Two 2Kw plinth heaters and electric radiator

KITCHEN / DINING AREA

- Integrated under counter fridge
- Integrated microwave
- 2 burner gas hob with extractor fan
- Domestic style rectangular sink bowl with drainer and under counter bin
- Full height kitchen furniture
- Stylish solid kitchen doors in 'light grey' perfect touch
- Tile effect acrylic kitchen splashback
- Under cupboard LED strip lighting
- Copper finish taps and handles to kitchen units
- Rear dining area with seating up to six and freestanding table
- Wall mounted pull down fixed double bed
- Dressing area with mirror and drawer unit
- Full height single wardrobe
- Second wall mounted dedicated TV position
- Access ladder to high level double or twin beds with flush fitting downlights in bunk area
- Balustrade with increased height
- Additional storage behind ladder
- Bunk bed area features two 230V sockets, USB points and rear ventilation windows

WASHROOM

- Large shower enclosure
- Electric heated towel radiator
- Dual flush contemporary WC with concealed system
- Vanity cupboard with sink
- Shaver socket
- Extractor fan
- Fixed water heater in dedicated cupboard

OPTIONS

- Condensing gas combi-boiler central heating and hot water system with towel radiator in washroom and radiators in lounge and rear living area
- Sierra Brown CanExel cladding with anthracite glazing
- Acadia Green CanExel cladding with anthracite glazing
- 'SwiftShield' lounge fabric
- Bluetooth audio connection to lounge ceiling speakers
- Full oven, grill and 4 burner hob with glass lid, and full height splashback
- Integrated 12 place setting dishwasher
- Morco Touch thermostatic controls

*S-Pod
Escape 6*



S-Pod
Escape 6

S-Pod

SIX



Now comes with sliding doors

S-POD DIMENSIONS

Swift's hugely popular S-Pod 6 offers ample accommodation and features, as well as an efficient footprint.

Whether you choose the stylish S-Pod 6 with its vaulted ceiling, or the ingeniously designed S-Pod 6 Escape, you can be assured of an absolute Tardis filled with natural light via glass front aspects.

The S-Pod 6 Escape, with an integrated veranda is perfect for al fresco dining, evening drinks or simply enjoying the views.

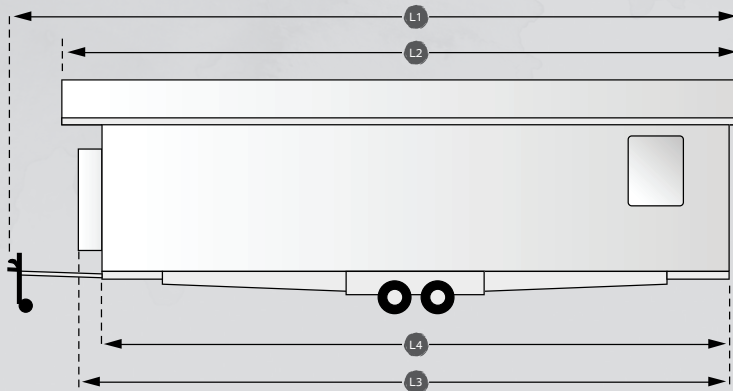
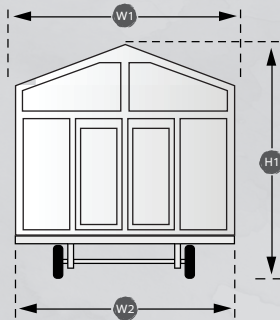

- L1** Overall length including detachable towbar
- L2** Overall length excluding detachable towbar
- L3** Body length at floor level
- W1** Overall width including gutters and down pipes
- W2** Width at floor level
- H1** Overall height

S-POD 6

- L1** 7.40m (24'3")
- L2** 6.72m (22'1")
- L3** 6.44m (21'1")
- W1** 3.99m (13'1")
- W2** 3.70m (12'2")
- H1** 4.18m (13'8")

S-POD 6 ESCAPE

- L1** 9.38m (30'9")
- L2** 8.89m (29'2")
- L3** 8.56m (28'1")
- W1** 3.99m (13'1")
- W2** 3.70m (12'2")
- H1** 4.18m (13'8")

The S-Pod is of rigid construction and not flat pack assembly, so site access needs to be considered and depending on access it may require craning onto your property. Please check the dimensions of the space you are planning to site the S-Pod to ensure you have an appropriate area to install a suitable base to site the product.



DO I NEED PLANNING PERMISSION FOR MY PROJECT?

WHAT IS PLANNING PERMISSION?

Planning permission is a form of consent given by local authorities for the erection, alteration or redevelopment of a particular plot of land or building. It is always recommended that you consult with your local planning department before siting an S-Pod on your land.

WHAT IS AN S-POD?

For the purposes of planning permission, models in the S-Pod range are classified as caravans.

Under section 29 of the Caravan Sites and Control Development Act 1960, a caravan is any structure built for human habitation which can be moved from one place to another. It must not measure more than 20m in length, 6.8m in width and 3.05m in height (measured internally from the floor to the ceiling at the lowest to the highest point).

DOES AN S-POD NEED PLANNING PERMISSION?

If your S-Pod is for commercial use, you will need to obtain planning permission. Go to the section on 'What happens if my S-Pod requires planning permission?' (see next page)

If your S-Pod is for private use, then you may not need planning permission depending on your circumstances.

PERMITTED DEVELOPMENT:

Where planning permission may not be required.

In certain circumstances, an S-Pod can be situated on land without the need for obtaining planning permission under The Town and Country Planning (General Permitted Development) Order 1995, provided that there has been no 'material change of use' to the land.

Some examples of where permission may not be needed are:

• When the S-Pod is sited within the curtilage of a dwelling

An S-Pod may be stationed within the curtilage (this term accounts for the garden, but NOT an adjoining piece of land such as farmland, a paddock or a wood) of a dwelling provided that it is being used as an annexe to the primary dwelling (for example, as a home office, or extra bedroom accommodation) by family or friends. Access must be via an existing road or path which cannot be obstructed by the S-Pod. It must not obstruct the view for drivers using any adjacent roads.

• As accommodation for building or engineering purposes

An S-Pod can be used to accommodate people taking part in authorised building works on the same piece of land, but it must be removed once building works are finished.

Even when circumstances may be compliant with the above, there are exemptions from permitted development and these include:

- There is no permitted development if the house is within an Area of Outstanding Natural Beauty (AONB), a National Park, a flat/maisonette building or a Listed Building.
- The development must be to the rear or side of the property. It cannot be in front of the property.
- The overall height of a dual pitched roof structure must not be more than 4 metres. The eave height must be no more than 2.5mtrs. If it is greater than this, the development must be at least 2 metres away from the garden boundary.
- The footprint cannot be greater than 50% of your original garden space.
- The development must be single storey and must not extend beyond the rear of the existing external wall by more than 4 metres, if a detached house, or 3 metres for any other type of dwelling.
- The height cannot exceed the highest part of the original dwelling.
- The development cannot be used as a self-contained living accommodation.
- The development cannot be used as a way to generate income.

- Permitted Development does not apply if the property you live in has previously been used for another purpose, for example a shop that has had a successful change of use.

Please note that some areas of the country ("Designated Areas") are even more restrictive than the above list with Permitted Development.

Permitted Development can also be removed from certain areas under an Article 4 Direction meaning that you will have to submit a planning application where otherwise it would not be required.

It is recommended that a 'Certificate of Lawful Development' is gained where planning permission is not required, for peace of mind.

If you are unsure whether your development falls under Permitted Development, or if it is for commercial use, you will need to contact your local council for permission.

WHAT HAPPENS IF MY S-POD REQUIRES PLANNING PERMISSION?

This is the case for all commercial ventures as well as any circumstances which fall outside of Permitted Development.

WHAT TYPE OF PLANNING DO I NEED?

If you are sure that you want to use your S-Pod for commercial purposes, or your project does not comply with 'Permitted Development', then you will need to apply for 'Detailed Planning Permission' (also known as full planning permission). This will be valid for five months from the date of its issue.

HOW DO I APPLY FOR PLANNING PERMISSION?

Consult your local authority's website to establish whether or not your project requires permission, and what kind.

Approach your local council's planning department for a pre-application consultation in order to get up-front advice. Early consultation will give an indication of what policies the application will be judged against, whether there is a need for specialist input (such as historical or ecological considerations) and affords the opportunity to amend your application ahead of submission which could save frustration and cost further down the line.

Assess whether you need to consult an independent planning consultant, surveyor or solicitor to assist with your application.

Contact your neighbours and anyone else in the vicinity who may be affected. It is better to try and get them onside early rather than to wait until they're contacted by third parties about your application.

Submit your formal application, either online or by post.

WHAT SHOULD I INCLUDE IN MY APPLICATION?

When submitting your planning application your local planning department will provide you with the information they require to assess your case. As a minimum, you will likely need to include an application form, a plan of the site and a copy of any sketches showing the proposed plan.

The planning process will review the following as standard:

- Landscape impact - How the development will impact the landscape from the road, public rights of way, neighbour's vantage points etc.
 - Highway impact - How visitors will leave and join the highway and how traffic will move around the site. Good access is key, as the Highways Agency holds a lot of power.
 - Local neighbourhood plan - This can sometimes include notes about holiday sites.
 - Current usage - For example, farmland comes under the NPPF (National Planning Policy Framework) which supports and allows for diversification on farms.
 - Precedence - If the land has been successfully used as something similar to the new intended use, then this increases the likelihood of achieving planning. For example, a touring caravan or camping site applying to have S-Pods.
 - Property with an agricultural tie - Permission is often granted for building accommodation on agricultural land, if the person living in it, gains their income from working in agriculture. This is conditional planning permission consent, known as a tie, the removal of which is difficult.
- Your pre-application meeting will have given you a good idea of what the planning office expect in order for your application to be successful. It is suggested that information on the economic value of your site, both directly to your business, and indirectly to the wider local economy, is important, as hiring out the development could be argued as an additional income as part of a rural enterprise

and/or diversification. Any extra information you have which may strengthen your argument is also advisable - for example if it is on the site of a Listed Building, then the applicant could argue that they have a greater financial burden, as they must maintain the house and the revenue from the development would create funds which would help to pay for the ongoing conservation of the listed building.

WHAT HAPPENS ONCE MY PLANNING APPLICATION IS SUBMITTED?

A full planning application will be publicised to members of the public and consultees such as affected parish councils, wildlife organisations and relevant agencies (for example, the Environment Agency) who are invited to comment. Planning officers at the council will then summarise the application along with a recommendation to approve, refuse or defer a decision pending further information. Recommendations at this stage are based on the merit of the application and whether it complies with the local development plan and central government guidance. Some applications are then presented to local councillors who make a final decision, which may or may not follow the planners' recommendations, depending on local objections. Many uncontentious applications are decided by planning officers who have been approved with 'delegated powers'.

HOW MUCH DOES APPLYING FOR PLANNING PERMISSION COST?

This depends on many factors such as variations between local authorities, the size and scale of your project and the extent to which you will require advice from consultants. The online planning portal will give you further information on this.

HOW LONG DOES IT TAKE TO RECEIVE A DECISION?

Your local authority has eight weeks to make a decision from the date of registration, increasing to thirteen weeks for applications for sites over one hectare. If an Environmental Impact Assessment is required then the statutory time limit for a decision increases to sixteen weeks.

IS THERE ANYTHING ELSE I NEED TO KNOW?

If you intend to let your S-Pod as a commercial venture, it is likely that you will also need a site licence which will detail requirements such as spacing between units, the need for a gas safety certificate (where applicable), refuse disposal, road access etc.

This information is correct as of the date of publication and is to be used as guidance only.

Swift Group do not offer legal or other professional advice and shall not be held responsible for any outcome due to persons acting, or refraining from acting, as a result of this material.

Individual planning circumstances differ, as do the requirements for each local authority, therefore it is always recommended that any advice you seek is from a qualified professional and relevant to your unique case.

S-POD PROJECT CHECKLIST

WHAT WILL YOUR S-POD BE USED FOR?

ACCOMMODATION ON PRIVATE LAND

COMMERCIAL VENTURE

DO YOU REQUIRE PLANNING PERMISSION?

NO, IT FALLS UNDER
PERMITTED DEVELOPMENT

YES

PERMITTED DEVELOPMENT CHECKLIST

CERTIFICATE OF LAWFUL
DEVELOPMENT

CONTACT WITH NEIGHBOURS

CONTACT WITH OTHER
INTERESTED PARTIES

APPOINT GROUNDWORKS
& SERVICES CONTRACTOR

PLANNING PERMISSION CHECKLIST

PRE APPLICATION MEETING
WITH LOCAL AUTHORITY

CONTACT NEIGHBOURS /
OTHER INTERESTED PARTIES

ASSESS NEEDS FOR
EXPERT ADVICE

SUBMIT APPLICATION

APPOINT GROUNDWORKS
& SERVICE CONTRACTOR

COMMERCIAL VENTURE CHECKLIST

In addition to Planning Permission Checklist

MARKETING

PROFESSIONAL IMAGES
(INTERNAL & EXTERNAL)

ADVERTISING

OUTLET - E.G. AIRBNB/
HOSEASONS ETC

PROMOTION

WEBSITE / SOCIAL MEDIA



SWIFT
CREATING SMILES FOR LIFE

S-Pod
SIX

S-Pod 6
Escape

Find out more at [swiftgroup.co.uk](https://www.swiftgroup.co.uk)

This brochure does not constitute an offer by Swift Group Limited (Swift). Swift reserves the right to alter specifications and prices at any time as materials and conditions demand. Distributors and dealers sell Swift products on their own account and not as agents of Swift. Accordingly, they have no authority to bind Swift or to make any representation or undertaking whatsoever on behalf of Swift. All props are for photographic purposes only and are not included in the specification. Models shown may be fitted with optional extras. Issued August 2021.

CARAVANS • MOTORHOMES • HOLIDAY HOMES - MADE IN BRITAIN BY SWIFT