

CREATING SMILES FOR LIFE



SWIFT

Swift Group Owner's Handbook

Basecamp

Issued August 2018

Part No. 1433208



A SUCCESS ON
DRAGONS'
DEN

luxury Comfort

ON THE MOVE



Duvalay are true pioneers – inventing the world's lightest bespoke caravan mattress, as well as innovative sleeping bags and portable toppers which have sold to more than one million customers globally.

To experience affordable bedtime luxury in every place you call 'home', choose Duvalay.

duvalayTM
BEDTIME LUXURY

Order online or by phone
duvalay.co.uk
01274 877 200



The only Swift Partner for Paint and Upholstery Protection



Diamondbrite
LEISURE



The only one with the Lifetime Guarantee

Paint Protection

Upholstery and Carpet Protection

From the Makers of Diamondbrite **Diamondbrite Leisure**

The ultimate Paint and Upholstery Protection for your Swift Basecamp

Diamondbrite Leisure is a two-step protection system for your Swift Basecamp with a Lifetime Guarantee*

1. EXTERIOR

- Nano-Ceramic Technology
- Fade Resistant
- Never Polish Again!

2. INTERIOR

- Easy to Clean
- Stain Resistant
- Lifetime Guarantee

HOW DOES IT WORK?

1 If your paintwork was magnified it would reveal small pores in the surface.

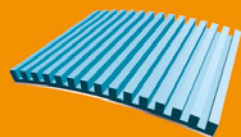

2 Road traffic dirt gathers in the pores and attacks paintwork.

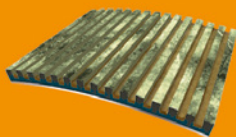

3 Your first Paint Protection application cleanses and fills pores in the vehicles paintwork leaving a smooth finish that cannot be penetrated.

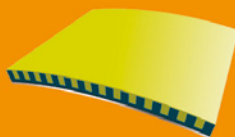

4 Your second application bonds with the first to create a hard protective skin. It leaves a high lustre finish that rain and dirt cannot penetrate.



You will also receive a complimentary After Care pack including the fabulous Waterless Wash, plus a range of other professional cleaning products.

Jewelultra Ltd. Diamondbrite House, Ewell Lane,
West Farleigh, MAIDSTONE. ME15 ONG.

Tel **01622 815679**

Email diamondbrite@jewelultra.com

www.jewelultra.com



MADE IN UK



Diamondbrite
LEISURE

*Lifetime Guarantee applies for the length of time that the purchaser owns the vehicle and is non-transferable.



Your Swift Basecamp is fitted with Whale Water & Space Heating

**Working with Swift to maximise
the space indoors, so that you
can enjoy the great outdoors**

- **Comfort - More Space**
Our space heater is located under the floor to free up your valuable living and storage space
- **Convenience - Fast Hot Water**
Rapid Heat Water Heater - for hot water as soon as you need it
- **No compromise - for the most efficient use of your heating**
Choose to heat air OR heat water OR heat both together

 **Whale**[®]
Support

Phoneline
available
7 days
a week

For help or advice on your
Whale Heating System
please contact us.

Tel: +44 (0)845 217 2933

E-mail: info@whalepumps.com

www.whalepumps.com



Proud to manufacture in the UK



SWIFT
CONNECT DIRECT

STEP INTO CONNECT DIRECT

WHAT IS CONNECT DIRECT?

Connect Direct is an online system which personalises each customer's experience of owning their caravan. The system is now available across the entire range.

HOW DOES IT WORK?

Once you have logged on and created your profile, you will be able to access a whole host of information, specific to your caravan. In addition you will be able to have a direct line into the retail team, with the launch of a live chat facility.

Should a problem occur, you will be able to report a fault to us directly, enabling us to react

quickly and work together with your dealer to take the problem away from you the owner and resolve the issue as quickly as possible.

Product upgrades and notifications will be sent via Connect Direct keeping you up to date over the coming years. This online system provides a direct route for you into the Swift Group, and enables us to provide you with proactive Customer Service support, enhancing your experience.

Connect Direct is in addition to the traditional methods of contacting us.

The key benefits of Connect Direct are:

- Access to information 24/7
- Ability to report faults directly to us
- Product upgrades and notifications
- Live chat direct into our experienced retail team
- Upload service history records
- Service history reminders



CUSTOMER SERVICE



TECHNICAL



REPAIRS



CUSTOMER CHAT

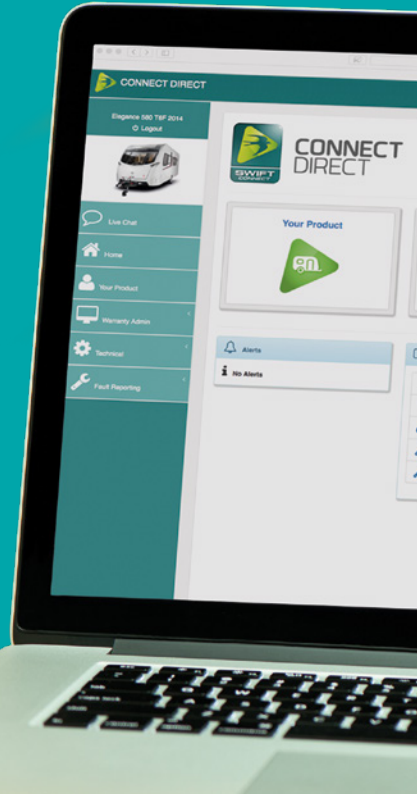

PURE CONTROL



At the Swift Group we're continually looking for ways to enhance your enjoyment of the outdoors. Swift Command is a real innovation designed to make your touring experience even more carefree.

Swift Command technology includes a smart new LCD touch screen control panel that has enhanced control panel functions. There is also an exciting, free downloadable 'app' that links to the Swift Command unit, so you can be in control from the comfort and convenience of your mobile device.

Swift Command is now available across the entire range.



Head to the Apple or Android store and search for 'Swift Command'.



LIGHTING

Create just the right ambience onboard with easily adjustable lighting settings.



LOCATION AND REMOTE FEATURES

Connect to your leisure vehicle from any where to view its systems information and location.

Conveniently control and monitor selected onboard services when away from your vehicle.



WATER

Keep an eye on your precious water levels so you know in good time when to top-up.



POWER

Track your energy use and manage your batteries for efficient use of your all important power services.



HEATING

Activate whilst out exploring and enjoy the warmth when you get back.

Dear owner

Thank you for deciding to buy one of our new caravans.

We are sure you will enjoy many happy hours in it and we hope the information and hints in this handbook will heighten your enjoyment.

The handbook has been designed to give you a general guide to the care, use and maintenance of your caravan. Whether you are a new or an experienced caravanner the hints will help to protect your investment.

The information contained will answer most of your queries, but if there are any aspects which are not covered please consult your appointed dealer. We would suggest you make a note of your dealers name and contact information below.

Throughout the season, specifications and equipment details contained within this handbook may change. Please refer to our online handbooks (www.swiftgroup.co.uk) for the most up-to-date version of your handbook.

This handbook contains general information for the use and care of your product. It also contains technical information and weights and dimensions of your product.

Dealer Name:

.....
.....

Telephone Number:

.....
.....

E-mail:

.....
.....

Serial Number:

.....
.....

First Service Due:

.....

Dealer Contact Sales:

.....

Dealer Contact Parts:

.....

Dealer Contact Service:

.....

Swift Talk

Swift Talk is the central forum for the Swift community online. A place for all those united in their love of caravanning, motorhomes, holiday homes and touring in general, to share their experiences, meet new friends and find out a world of information on how to enjoy their touring lifestyle.

The site is packed full of features that actively encourage members, not only to liaise with the Swift Group via the forums, but also interact with each other through publishing their own content, uploading and sharing photos and video, and even posting their own blogs for the community to follow.

Swift Talk is the first place to learn about new product launches, events and Swift Group news, it's also the first place customers can go to as a quick reference to frequently asked questions or to actively take part in the forums; providing valuable feedback on Swift Group products and customer service.

The online community can even be used to create your own groups, perfect for Owners' Clubs, dealers and exhibitors to attract new members, publicise and build awareness for upcoming events, rallies and shows.

Anyone who owns, uses, or is thinking of buying a Swift Group caravan, motorhome or holiday home, or would just like to be part of the growing Swift community is actively encouraged to sign up, create their own content, and start talking!

Just visit www.swift-talk.co.uk and become part of a unique online experience.



SWIFT

TALK

Warranty	5
Towing code	13
Safety & security	37
Services	43
Electrics	63
Fitted equipment	97
Maintenance	119
Useful information	155
Index	162

WARRANTY INFORMATION

Warranty	6
Change of ownership	8
Swift Connect Direct	8
What to do if you require assistance	8
Touring caravans - annual service/inspection record	9
Annual service / inspection record stamps	10

All the illustrations and descriptive matter in the handbook are intended to give a general idea of the caravan. Changing market and supply situations and our policy of continuous product development may prevent us from maintaining the exact specifications detailed in the handbook. We therefore reserve the right to alter specifications as materials and conditions demand.

Dealers are not agents of Swift Group Limited ("Swift") and have absolutely no authority to bind the manufacturer by any express or implied undertaking or representation.

Note: To register your warranty, please use the Connect Direct Registration process, by doing so you are agreeing that you have had the details of the warranty and the annual service arrangements fully explained. This in no way affects your statutory rights under the Consumer Rights Act.

Your caravan has three warranties:

SuperSure Warranty

For all parts or fittings of your caravan other than the body shell, Swift will repair (or at its option, replace) any defective parts or fittings for 3 years from the date of purchase (or hire purchase) subject to conditions, terms and exclusions below.

Body Shell Warranty

For the body shell, Swift will repair (or at its option, replace) any defects with the body shell for 6 years from the date of purchase (or hire purchase), subject to the conditions, terms and exclusions below.

Extended Body Shell Warranty

For the first owner, Swift will repair (or at its option, replace) any defects with the body shell for 10 years from the date of purchase (or hire purchase), subject to the conditions, terms and exclusions below.

Conditions

1. You must ensure that your caravan has had an Annual Service (see clause 2 below) within 90 days before or 60 days

after each anniversary of the original date of purchase. In order to preserve your SuperSure Warranty, the third Annual Service must be carried out before the expiry of the 36 month period from the original date of purchase. In order to preserve your Body Shell Warranty, the sixth Annual Service must be carried out before the expiry of the 72 month period from the original date of purchase. In order to preserve your Extended Body Shell Warranty, the tenth Annual Service must be carried out before the expiry of the 120 month period from the original date of purchase. If you have not performed an Annual Service then Swift will not be obliged to perform any work under the applicable warranty. Original VAT invoices must be retained as proof that Annual Services have been carried out.

2. The Annual Service must be carried out in accordance with the requirements in this handbook. You will be responsible for any charges made for an Annual Service. If the Annual Service is performed by an authorised Swift Group Service Centre then Swift warrants that the Annual Service has been performed correctly. If the Annual Service is performed by an unauthorised repairer or service centre then if the Annual Service has not been performed in accordance with the requirements in this handbook and/or work has been performed on your caravan that is defective or faulty, then Swift will not be obliged to perform any work under this Warranty (insofar as it relates to defective or faulty work or defective Annual Service).
3. All new caravans must be registered with Swift within 6 weeks of purchase as new.
4. The benefit of the SuperSure Warranty and Body Shell Warranty may be transferred to a new owner if the caravan is re-sold, provided that the caravan has been serviced in accordance with the requirements of this handbook, and details of the change of ownership have been supplied to Swift using the change of ownership form set out in this handbook as soon as reasonably practicable after the change.

5. The benefit of the Extended Body Shell Warranty is non transferable to new owners and applies only to the original registered owner.
6. If any repairs are identified as being necessary during an Annual Service or otherwise, Swift will only pay for Warranty work performed by an authorised Swift Group Service Centre. The caravan must be made available to an authorised Swift Group Service Centre within 6 weeks of the date the repair need was identified for the work to be carried out. The cost of transporting, towing or moving the caravan by any means to or from the place of repair is the responsibility of the owner.
7. The SuperSure Warranty, the Body Shell Warranty and/or the Extended Body Shell warranty only apply to caravans purchased and used primarily within the UK.

Terms

8. The Body Shell Warranty and Extended Body Shell Warranty cover any defect with the panels and seams of the caravan. This includes body leaks, delamination of panels or floor, water ingress through any permanently sealed seam joints.
9. The SuperSure Warranty will cover in the first 12 months any defect other than those specified in the Exclusions below.
10. In years 2 and 3 of the SuperSure Warranty, the Warranty will only cover any defect with the following components:
 - **Chassis Components:** all chassis members, including corner steadies, overrun device, axle and braking system (excluding brake drums and shoes)
 - **Electrical System:** PSU, battery charger, Smart Command and interior lighting units (excluding bulbs).
 - **Water System:** water heater, fresh water tank, water pump, water gauges, taps and shower head.
 - **Cooker:** the cooker unit including grill, oven, burners, igniter and flame failure device.
- **Refrigerator:** gas igniter, flame failure device, door seal condenser, gas control valve, 12V and 230v heater elements, gas thermostat, 230v thermostat and 230v temperature control switch
- **Cassette Toilet:** the cassette toilet (excluding seals, valves and glands)
- **Heating System:** thermostat, motor, switches, control unit, gas heater, flame failure device and igniter (excluding ducting and fittings)
- **Windows:** the functionality of the opening and closing system (stays, handles and catches) and a warranty against the cracking of the acrylic. Excludes fading.
- **Upholstery:** zips, seams and colour fastness

In years 2 and 3 of the SuperSure Warranty, any defect specified in the Exclusions will not be covered.

Exclusions

11. Swift shall not be liable under this Warranty for any defect related to or arising from the following:
 - The failure of a component for reasons of fair wear and tear;
 - Damage resulting from freezing, fire, overheating or accidents (whether caused by the user or a third party);
 - Misuse of any component;
 - Normal deterioration, corrosion, intrusion of foreign or harmful bodies, lack of servicing or negligence of any person other than Swift which causes stoppage of or impairment to the function of any component of the caravan;
 - Replacement of parts which have reached the end of their effective working life because of age and/or usage;
 - Cleaning or adjustment of any assemblies;
 - Cosmetic finishes to kitchen sinks, cooker tops, vanity units, shower trays.
 - Damage caused by any abrasive cleaners
 - Issues related to condensation in normal use;

ASSISTANCE

- Routine maintenance items which are part of the annual service including brake shoes, one shot nuts, lubricants, AKS pads, rubber gas hose, the cleaning of the heater and fridge flues, the replacement of gas jets, the resealing and/ or replacement of shower room sealant, and the adjustment and lubrication of locks.
12. In addition to the exclusions above, in years 2 and 3 of the SuperSure Warranty Period, Swift Group Limited shall not be liable under this Warranty for any defects related to:
- **Alloy wheels:** after 24 months from date of purchase, this excludes wear and tear, (tyres & valves excluded).
 - **Wall and Roof GRP sheeting material:** after 24 months from date of purchase only

WARRANTY INFORMATION

Swift shall also not be liable under the SuperSure, Body Shell and Extended Body Shell Warranties if the Caravan has been neglected, misused, modified or used for hire or reward or if the identification marks (chassis/VIN numbers) have been removed or defaced. The caravan will be deemed to have been neglected if it has not been serviced and maintained as stated in this handbook or any repairs being identified as necessary at an Annual Service or by a Swift Group Service Centre have not been carried out in a reasonable time.

You have legal rights under UK law governing the sale of consumer goods. These warranties do not affect your legal rights.

The name and address of the Warranty provider is:

Swift Group Limited, Dunswell Road, Cottingham, East Yorkshire, HU16 4JX

To make a claim under this Warranty, contact the Swift Group Dealer which supplied your caravan. Alternatively, details of your nearest authorised Swift Group Service Centre can be obtained by contacting the Swift Group Customer Service Department on 01482 875740, or enquiring on the website www.swiftgroup.co.uk

Change of ownership

You can transfer the remainder of any 3 year 'Supersure warranty' and the 6 year 'body shell' warranty, details of how to do this can be found at the rear of this handbook. The 'Extended Body Shell Warranty' is non transferable.

Swift Connect Direct

You have access to an online system which is specific to your new caravan. A password will be issued to you, to enable you to interact with us. To access the system, called 'Swift Connect Direct', your initial log in details will be emailed to you once your supplying dealer has registered your ownership with us. Please log in and create your own profile. Should you have issues with accessing Swift Connect Direct, please contact our Customer Services Team.

What to do if you require assistance

Should you have an enquiry or require assistance with a problem, we hope that this guide will be of assistance to you.

Please follow these steps:

1. Check the Owners Handbook, paying particular attention to the fault finding advice at the back of the book.
2. Contact your supplying dealer for assistance.

If you need to contact the Swift Group, please be aware of the following:

1. When contacting Swift Customer Service, please quote your name, postcode and serial number of your caravan. This can be found on the weight plate labels located next to the exterior door and inside the gas locker. It is also etched into the side windows.
2. In most instances, the Customer Service Team will involve your dealer in resolving the issue you are experiencing.
3. Check our website www.swiftgroup.co.uk and enter the Owners section which provides answers to frequently asked questions and how to contact us.

4. If you are contacting the company by email, letter or fax, the Customer Service Team will respond to you within five working days from the date of receiving the correspondence.
5. Please be aware that the Swift Group cannot send parts direct from the factory. In all cases, without exception, your dealer must place the order for you.

Touring caravans - annual service/inspection record

In order to comply with the warranty, you must have your caravan inspected and serviced at least once per year.

We highly recommend that you have your Touring Caravan serviced by a Swift Group Approved Service Centre who have direct access to our online Customer Service system, Connect. This system provides them with the ability to order approved parts and ensure that any product upgrades which may be available for your Touring Caravan can be offered to you and carried out as part of the service. In the unfortunate event that an issue requires attention under warranty then a Swift Group Approved Service Centre are able to submit a warranty claim to the Swift Group for processing, and deal with the issue for you from start to finish. All of our Swift Group Approved Service Centres are provided with up to date technical information and have access to current repair methods giving you peace of mind that any defect has been repaired effectively.

It is important that the Service inspection Record is updated. Your Swift Group Service Centre have the facility to do this on line. Should proof of service be requested at any time you will need to produce a copy of the service invoice, therefore please keep this for your records. Failure to provide proof of service may invalidate the warranty and the transfer of the warranty on the change of ownership.

The inspection should take approximately two to four hours and will cover the areas dealt with in the annual service check list. Any areas requiring service and/or maintenance will be

highlighted by your dealer and we recommend that you authorise any necessary work to be carried out.

Note: It is essential, to validate the warranty, that an annual inspection be carried out by an authorised Swift Group Service Centre covering the items listed.

1. Damp and lamination test. This is a visual inspection of bodywork and seals.
2. Coupling head and breakaway cable.
3. Jockey wheel.
4. Chassis and chassis to body security.
5. Corner steadies.
6. Tyres and tyre pressures.
7. Torque wheel nuts.
8. Brake rods and linkages.
9. Hub bearings, brakes and brake shoes.
10. Handbrake operation and performance.
11. Suspension and shock absorbers (if fitted).
12. 13 pin plug and cables.
13. Road lights, wiring and reflectors.
14. Internal lights and 12V DC system.
15. Water heater - gas and 230V AC (if fitted).
16. Hob, grill and oven (if fitted).
17. Refrigerator 230V AC, 12V DC and gas.
18. Gas system.
19. Water pump, taps and water system.
20. Mains 230V AC system.
21. Windows and fittings.
22. Smoke alarm and battery.
23. Roof lights.
24. Furniture hinges/stays etc.
25. Exterior locks and hinges.
26. Grab handle security.
27. All internal vents.
28. Oil seals.
29. Blinds and fly screens (if fitted).
30. Carbon Monoxide detector.

SERVICE INSPECTION

<p>Annual service / inspection record stamps</p> <p>Caravan model:</p> <p>Year:</p> <p>Chassis Number:</p>	<p>1st service</p> <p>Date:</p> <p>Dealer's Stamp</p> <p>We certify that an annual service has been carried out in accordance with the handbook.</p>
<p>2nd service</p> <p>Date:</p> <p>Dealer's Stamp</p> <p>We certify that an annual service has been carried out in accordance with the handbook.</p>	<p>3rd service</p> <p>Date:</p> <p>Dealer's Stamp</p> <p>We certify that an annual service has been carried out in accordance with the handbook.</p>
<p>4th service</p> <p>Date:</p> <p>Dealer's Stamp</p> <p>We certify that an annual service has been carried out in accordance with the handbook.</p>	<p>5th service</p> <p>Date:</p> <p>Dealer's Stamp</p> <p>We certify that an annual service has been carried out in accordance with the handbook.</p>
<p>6th service</p> <p>Date:</p> <p>Dealer's Stamp</p> <p>We certify that an annual service has been carried out in accordance with the handbook.</p>	<p>7th service</p> <p>Date:</p> <p>Dealer's Stamp</p> <p>We certify that an annual service has been carried out in accordance with the handbook.</p>

<p>8th service</p> <p>Date: Dealer's Stamp</p> <p>We certify that an annual service has been carried out in accordance with the handbook.</p>	<p>9th service</p> <p>Date: Dealer's Stamp</p> <p>We certify that an annual service has been carried out in accordance with the handbook.</p>
<p>10th service</p> <p>Date: Dealer's Stamp</p> <p>We certify that an annual service has been carried out in accordance with the handbook.</p>	<p>11th service</p> <p>Date: Dealer's Stamp</p> <p>We certify that an annual service has been carried out in accordance with the handbook.</p>
<p>12th service</p> <p>Date: Dealer's Stamp</p> <p>We certify that an annual service has been carried out in accordance with the handbook.</p>	<p>13th service</p> <p>Date: Dealer's Stamp</p> <p>We certify that an annual service has been carried out in accordance with the handbook.</p>
<p>14th service</p> <p>Date: Dealer's Stamp</p> <p>We certify that an annual service has been carried out in accordance with the handbook.</p>	<p>15th service</p> <p>Date: Dealer's Stamp</p> <p>We certify that an annual service has been carried out in accordance with the handbook.</p>

WARRANTY

Supplier contacts

A number of Swift Group suppliers manage their own Technical and Warranty related queries. Where a customer has a question relating to a product manufactured by a company listed below, we would advise that the first contact should be directly with them.

SARGENT**Sargent Electrical Services**

Unit 39, Tokenspire Business Park,
Beverley, East Yorkshire, HU17 0TB
Phone: 01482 678981
Fax: 01482 678987
E-mail: support@sargentttd.co.uk

<https://sargentttd.co.uk>**AL-KO****AL-KO Kober Limited**

South Warwickshire Business Park
Kineton Road, Southam,
Warwickshire, CV47 0AL
Fax: 01926 818562
Email: mail@al-ko.co.uk

<http://www.al-ko.co.uk>**Truma****Truma UK Ltd.**

Park lane, Dove Valley Park,
South Derbyshire, DE65 5BG
Phone: 01283 586020
Fax: 01283 586029
technical@trumauk.com

<https://www.truma.com/uk/en/home/index.php>**THETFORD**
Corporation**Thetford Ltd.**

Unit 6, Brookfields Way, Manvers,
Dearne Valley, Rotherham,
South Yorkshire, S63 5DL
Phone - 0844 997 1960
Fax - 0844 997 1961
Email - infogb@thetford.eu

<https://www.thetford-europe.com>**Alde****Alde International (UK) Ltd**

Huxley Close, Park Farm South,
Wellingborough, Northants, NN8 6AB
Phone: 01933 677765
Fax: 01933 674975
Email: info@alde.co.uk

www.alde.co.uk**Dometic****Dometic (UK) Ltd**

Dometic House, The Brewery,
Blandford St Mary, Dorset, DT11 9LS
Phone: 0844 626 0133
Email: technical@dometic.co.uk

<https://www.dometic.com/en-gb/uk>**Whale****Whale**

2 Enterprise Road, Bangor,
Co. Down, Northern Ireland BT19 7TA
Phone: 0845 217 2933
Email: info@whalepumps.com

<http://whalepumps.com/home.aspx>

Caravan towing code	14
Caravan terms	14
Towing vehicle terms	16
Measurement of nose weight	16
Type of driving licence held	17
Glossary & checklist	17
Useful memory aid	19
Preparing for the road	20
Tyre Maintenance	23
The Tyre Law	24
Hitching up for AK160	24
Pre tow check list	26
13 Pin Socket	27
Towcar electrics.....	28
Breakaway Cables	29
Mirrors	31
Moving off	31
Reversing	31
Speed limits	31
Caravan handling	32
Motorway driving	32
Spare wheel	32
Changing a wheel	33
Wheel Bolt tightening	33
Jacking points	33
Stopping on a hill	34
Arrival on site	34
Exterior Door	35

TOWING CODE

Caravan towing code

This Code of Practice contains recommendations jointly reviewed and agreed by the following organisations:

The National Caravan Council
 The Caravan Club
 The Camping and Caravanning Club
 The Caravan Writers Guild
 The Department for Transport

Scope of the Code

The Code applies to all trailer caravans of maximum laden weight not exceeding 3500 kg, overall width not exceeding 2.3m (7ft 6in approximately) and overall length not exceeding 7m (23ft approximately), excluding the drawbar and coupling.

This is legally the maximum size of trailer that can be towed by a motor vehicle with a maximum gross weight of less than 3500 kg.

Caravan terms

Empty Weight

The empty weight of the caravan includes all loose items supplied by Swift e.g. Electric hook cable, kit bag, entrance step, portable waste tank and central heating fluid (where applicable).

Mass in Running Order:

The mass of the caravan equipped to the caravan manufacturer, standard specification.

The MRO comprises the empty weight of the caravan and includes an allowance for gas.

Note: The mass of the caravan in running order contains provision for the masses of liquids, gas etc. (see Mass in Running Order in the Technical Handbook). Part of this provision can also be utilised as additional payload, if for example, you wish to travel with no gas cylinders.

Maximum User Payload:

The maximum allowable weight to be put into the caravan whilst it is being towed.

This is made up of the personal effects and the optional equipment payloads.

The user payload is the difference between the Maximum Technically Permissible Laden Mass and the Mass in Running Order.

The Mass in Running Order + Personal Effects + Optional Equipment = Maximum Technical Permissible Mass or MRO + PE + OE = MTPLM

Personal Effects

Those items which a user can choose to carry in a caravan.

Note: The Personal effects payload includes an allowance of 20kg for a leisure battery.

Optional Equipment

Items made available by the manufacturer over and above the standard specification of the caravan for factory fitted options.

Maximum Technically Permissible Laden Mass (Lower Limit):

The fully laden mass of the caravan in the manufacturers standard specification which is stated in the publications, technical handbooks, brochures and weight plate and used for car matching.

Maximum Technically Permissible Mass (Upper Limit):

The mass takes into account specific operating conditions including factors such as the strength of materials, loading capacity of tyres, etc.

Payload Definition

The method of calculating the Mass in Running Order (MRO) and user payload figures are in line with European Vehicle Directives.

Allowances for essential equipment is now contained within the MRO of the caravan and as per NCC code of Practice (CoP) 304.

This includes the following;

LPG 1 x cylinder = 10kg

The MRO is calculated with the fresh water tank empty.

Note: If you travel with water in the fresh water tank, the payload will be reduced accordingly.

The leisure battery is considered to be included in the personal effects and an allowance of 20kg has been made for this. Items fitted at the point of manufacturer (wheel locks, hook-up cable, plastic steps, waste containers, etc.) are included within the vehicle MRO.

⚠ WARNING: Under no circumstances should the maximum technically permissible laden mass (MTPLM) be exceeded.

Upgrading of maximum technically permissible laden mass:

The lower (or standard) MTPLM is quoted in the Technical Handbook, in brochures and on the caravan weight plate. However, in some cases it may be possible to increase this to a higher (upper) MTPLM. (See Technical Handbook for details).

If extra user payload is required, an upgrade maybe available (model dependant), this must be requested via your dealer and is chargeable.

If required you will be issued with the following:

- (i) New weight plate giving upgrade weight details.

- (ii) New NCC certificate (declaring the upgraded MTPLM)
- (iii) Manufacturers letter confirming the upgrade for that Vehicle Identification Number.

Note: Tyre pressures may increase when upgrading the MTPLM.

Nose weight:

The vertical weight transferred to the towing vehicle through the coupling head.

Notes:

- (i) When measuring the noseweight it is important that the caravan is fully loaded. Do not place extra items indiscriminately into the caravan after this adjustment has been made.
- (ii) The caravan is intended to be towed slightly nose heavy. The nose weight can be adjusted by distribution of the load within the caravan. The nose weight should be approximately 5%-7% of the actual laden weight (but not greater than the hitch capacity) and at the same time suit the towing vehicle. See section on Measurement of Nose Weight.
- (iii) It is not recommended that you tow with just a battery, spare wheel and gas bottles as this may exceed the permitted nose weight. Additional payload must be placed behind the axle to compensate for this.

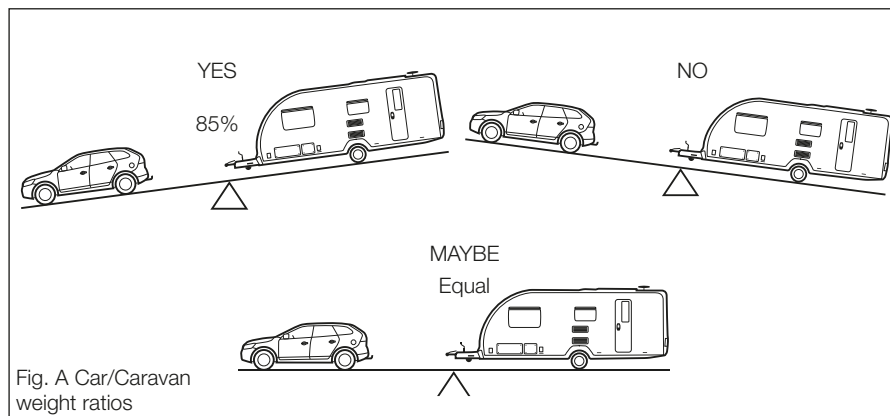

Fig. A Car/Caravan weight ratios

TOWING VEHICLE TERMS

Towing vehicle terms**Kerb weight****(Mass of Vehicle in Running Order):**

The weight of the towing vehicle as defined by the vehicle manufacturer. This is normally with a full tank of fuel, with an adequate supply of liquids incidental to the vehicles propulsion, without driver or passengers, without any load except loose tools and equipment with which the vehicle is normally provided and without any towing bracket.

Caravan to Towing Vehicle Weight Ratio:

The towing vehicle to caravan weight ratio can be determined by calculation and is equal to:

$$\frac{\text{Actual laden weight of caravan}}{\text{Kerb weight of towing vehicle}} \times 100\%$$

The law requires that caravans & their towing vehicles & the loads they carry must be in such a condition that no danger or nuisance is caused.

(Regulation 100 of the Road and Vehicles [Construction and Use] Regulations 1986).

Note: The towing vehicle manufacturer's limit is, in some cases, less than the kerb weight.

Mass in Running Order:

Caravanners can use a public weigh bridge to establish the mass in running order.

Note: Weigh bridges have varying weight tolerance levels.

Maximum Permissible Towing Mass:

The weight defined by the vehicle manufacturer as being the maximum that the vehicle is designed to tow at.

Train Weight (Combination Weight):

The maximum combined weight of the towing vehicle and trailer combination as specified by the towing vehicle manufacturer.

Measurement of nose weight

Nose weight may be measured using a propriety brand of nose weight indicator. Such equipment is obtainable at your Caravan Dealer.

Note: These indicators have a varying tolerance level and may not be accurate.

Another simple method is to use bathroom scales under the coupling head with a piece of wood, fitted between the coupling head and the scales, of such length that the caravan floor is horizontal with the jockey wheel raised clear of the ground. (Fig. A)

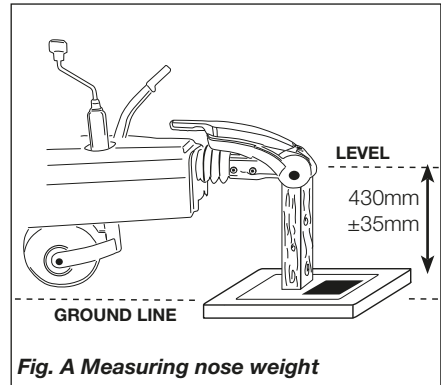

Fig. A Measuring nose weight

Nose weight can be adjusted simply by distribution of weights in the caravan.

Always lower jockey wheel before entering the caravan and then raise before measuring again. (See Loading).

Note: The height of the towball on the towing vehicle, when laden, is also critical. To comply with UNECE regulation R55 the towing vehicle tow ball should be between 350mm and 420mm from the ground.

⚠ WARNING: Do not lift the coupling head by hand when hitching the caravan to the car. Always raise and lower the coupling head by winding the handle on the jockey wheel up and down.

Driving licence

If you passed your car test before 1st January 1997 you are generally entitled to drive a vehicle and trailer combination up to 8,250kg maximum authorised mass (MAM). This is the weight of a vehicle or trailer including the maximum load that can be carried safely when it's being used on the road.

You can also drive a minibus with a trailer over 750kg MAM.

If you passed your driving test after 1st January 1997 and have an ordinary category B (car) licence, you can:

- Drive a vehicle up to 3,500kg MAM towing a trailer of up to 750kg MAM
- Tow a trailer over 750kg MAM as long as the combined MAM of the trailer and towing vehicle is no more than 3,500kg

For anything heavier you need to take a category B+E driving test.

From 19th January 2013, drivers passing a category B (car) test can tow:

- Small trailers weighing no more than 750kg
- A trailer over 750kg as long as the combined weight of the trailer and towing vehicle is no more than 3,500kg MAM

If you want to tow a trailer weighing more than 750kg, when the combined weight of the towing vehicle and trailer is more than 3,500kg, you'll have to pass a further test and get B+E entitlement on your licence.

Glossary & checklist

Awnings - Can consist of just a simple top sheet but may extend to a five sided frame tent attached to the side of the caravan.

Fire blanket - approved to BS 6575 is ideal for dealing with 'fat pan' fires.

Fire extinguisher - It is strongly recommended that a fire extinguisher is carried in the caravan. (For suitable types see Safety and Security).

Gas bottles - Bottled L.P. gas is the most convenient portable source of fuel. Ideally, two bottles are required for a constant supply.

An initial deposit is payable on each cylinder. We recommend the use of 6kg Calor Light Propane bottles. One position for use and one for storage only. (For detailed information see Services - Gas).

Jack - A suitable jack is essential (screw, scissor, side mounted or air jack type). Many car jacks are unsuitable. Ensure the lifting capacity of the jack is suitable for your caravan.

Levellers - Levellers help level the caravan from side to side before unhitching. Proprietary products can be purchased from your caravan dealer and need to be positioned as indicated by a spirit level.

Spare Wheel - It is always advisable to carry a spare wheel with your caravan.

Spirit Level - A spirit level is extremely useful when siting the caravan.

Stabiliser - Stabilisers help to dampen the side to side movement of the caravan.

Torque Wrench - A torque wrench is the only way that the exact recommended torque can be achieved for wheel nuts and bolts. (See Preparing for the Road).

GLOSSARY AND CHECKLIST

Towing Bracket - Never use cheap alternatives, obtain one manufactured by a reputable company complying with the relevant standards.

Any light passenger vehicle registered in the UK on or after August 1st 1998 will require a type approved towbar and towball (to 94/20/EC or UN ECE R55).

Failure to fit a homologated towbar and towball could result in a prosecution and invalidation of your insurance cover.

Always check with your car manufacturer or towbar manufacturer if in doubt.

Note: The height of the towball on the towing vehicle, when laden, is also critical. To comply with UNECE regulation R55 the towing vehicle tow ball should be between 350mm and 420mm from the ground.

Wooden Blocks - Wooden blocks typically 25cm square and 2cm thick are ideal for placing under corner steadies and jockey wheel when the ground is uneven or soft.

Water Containers - Two containers are required, one to carry fresh water to the caravan and one for waste water, which needs to be disposed of properly. Several types are available including jerry cans, Aquarolls, wastemaster, etc .

13 Pin Socket - One socket fitted to the car to accept corresponding plugs from the caravan this energises the road lights and caravan auxiliary circuits.

12 Volt Battery - A deep cycling, heavy duty rechargeable leisure type battery should be purchased to provide back-up power for lights and other electrical appliances. (See Battery). The securing arrangements for the battery compartment require a leisure battery complying with EN 60095-2 in particular those with ledges for fastening to the lower edge of the long sides. The maximum battery size that can be fitted is 225mm high, (including terminals) x 175mm deep x 353mm wide. The depth and width dimensions include the rim around the bottom used for securing the battery.

Note: Check first that the battery will fit within the battery box and can be secured before purchasing.

⚠ WARNING: Your caravan dealer should be consulted if additional equipment is to be fitted as strong points may or may not be provided in the design.

Caravan motor movers

The design and fitment of a caravan motor mover shall be in accordance with the NCC Code of Practice 305 and you should ensure you receive a signed installation certificate of compliance from the installer.

Failure to do so may invalidate your warranty.

Note: Fitting additional equipment, such as a motor mover will reduce the caravan allowable payload.

Note: The fitting of a motor mover may require a larger capacity battery fitting.

Note: If a towing cover is fitted, care should be taken not to obscure lights, reflectors and protect against rubbing or damaging the bodywork.

Useful memory aid**Car**

External mirrors
 Fire extinguisher
 Jack
 Petrol can
 Spare bulbs
 Spare keys
 Spare wheel
 Tool kit
 Towball cover
 Tyre pressure gauge
 Warning triangle
 Tyre pump
 Hi-Vis tabard(s)
 Breathalyser kit (some Euro countries)
 Headlight stickers (Beam deflectors)

Caravan

Awning pegs and poles
 Awning ground sheet
 Bucket
 Corner steady brace
 Corner steady pads
 Coupling lock
 Door mat
 Fire blanket
 Fire extinguisher
 Fresh water container
 Gas cylinders
 Jack
 Levelling boards
 Mallet
 Site/caravan mains lead
 Spare bulbs - (Mandatory in E.C.)
 Spare 12v fuses
 Spare high pressure gas hose
 Spare wheel
 Spirit level
 Toilet fluid
 Waste water container
 Wheel brace

Personal

After sun cream
 First Aid Kit
 Flannels
 Hairbrush and comb

Make up. etc.
 Raincoats
 Toothbrush
 Toothpaste
 Scissors
 Shampoo
 Shaving kit
 Shoe cleaning kit
 Soap
 Sun tan oil
 Wellington boots

Domestic

Adhesive tape
 Air freshener
 Aluminium foil
 Ashtrays
 Bedding
 Bin liners
 Binoculars
 Bottle opener
 Breadboard
 Brush and dustpan
 Butter dish
 Camera
 Carving knife
 Chairs
 Clock
 Clothes brush
 Clothes line
 Coat hangers
 Coolbox
 Colander
 Crockery
 Cruet
 Corkscrew
 Cutlery
 Dish cloth and brush
 Dusters and polish
 Disposable cloths
 Egg cups
 Floor cloth
 Fly spray
 Food
 Food mixer
 Frying pan
 Glasses
 Grill pan
 Jugs
 Kettle
 Kitchen roll
 Kitchen tools

Matches
 Measuring jug
 Milk jug
 Mixing bowl
 Needles and thread
 Oven gloves
 Pegs
 Piezo Gas lighter
 Potato peeler
 Radio
 Rubbish bin
 Saucepans
 Scissors
 Sieve
 Sugar bowl
 Shopping bags
 Sleeping bags
 Tea pot
 Tea strainer
 Tea towels
 Table cloths
 Table mats
 Television
 Tin opener
 Tissues
 Toilet paper
 Torch
 Towels
 Toys & Games
 Vacuum cleaner
 Washing up bowl

Documents

Bank and credit cards
 Caravan Certificate
 Cheque book
 CRIS document
 Driving licence
 Green Card
 Insurance (some Euro countries)
 Maps and guides
 Money
 MOT Certificate
 Vehicle Registration Documents

Gadgets

Mobile phone & charger

PREPARING FOR THE ROAD

Preparing for the road

Pre-load checklist

⚠ WARNING: Never enter the caravan without first lowering the four corner steadies with the brace provided.

Before loading check:

- loose articles are stowed securely. Do not stow tins, bottles or heavy items in overhead lockers prior to towing.
- all lockers and cupboard doors are closed and secured, including the bathroom door.
- all bunks are secure.
- ensure shower door is secure
- all rooflights are closed and secured.
- main table is stored in its transit position.
- television aerial is lowered and locked where applicable
- fridge is on 12V operation and door lock is set.
- all windows and service doors are fully closed and latched. Never tow with windows on night setting. Leave all curtains and blinds open to aid rear visibility.
- gas cylinders are correctly positioned, secured and turned off, unless using en route heating.
- battery is secure and mains connecting cable is disconnected and stowed.
- Ensure control panel settings are correct for 12v fridge operation. See control panel instructions for detail.
- Exterior door is closed and locked

⚠ WARNING: Turn off gas appliances when travelling.

⚠ WARNING: Do not travel with televisions or microwaves in overhead lockers unless the appliance was supplied fitted to your caravan by the manufacturer.

⚠ WARNING: Always disconnect the electrical connector between the towing vehicle and the caravan before connecting a LV supply to the caravan.

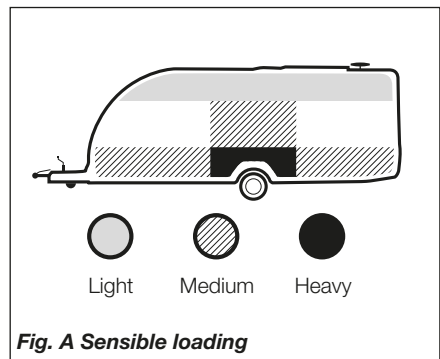
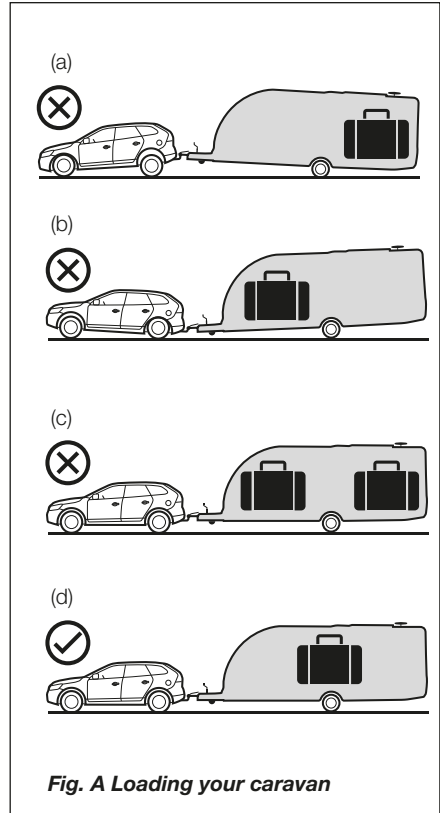

How to apportion it

1. Load heavy items low down near the floor and mainly over or just in front of the axle(s) (Fig. A).
2. Load evenly right to left so that each caravan wheel carries approximately the same weight.
3. Do not load items at the extreme front or rear since this can lead to instability due to the 'pendulum effect'.
4. Load remainder to give a suitable nose weight at the towing coupling.

Check nose weight.

Note: Do not overload car boot.

⚠ WARNING: All heavy and/or voluminous items (e.g. TV, radio etc) must be stored securely before travelling.

⚠ WARNING: Please take care to ensure that you have allowed for the masses of all items you intend to carry in the caravan. e.g. optional equipment, and personal effects such as clothing, food, pets, bicycles, sailboards, sports equipment etc.

⚠ WARNING: under no circumstances should the MTPLM of this caravan be exceeded

Towing vehicle's rear suspension

It is important that the towing vehicle's rear suspension is not deflected excessively by the nose weight on the tow ball. If it is excessive the steering and stability will be affected. (Fig. B)

The greater the towing vehicle's tail overhang (the distance between the rear axle and the tow ball), the greater the effect the nose weight will have on the towing vehicle's rear suspension.

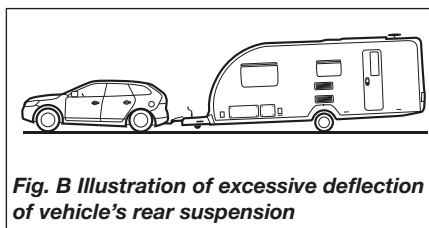

Fig. B Illustration of excessive deflection of vehicle's rear suspension

After trying out the caravan it may be found that a stiffening of the rear suspension is necessary - but note that this may give the towing vehicle a firmer ride when not towing.

There are a number of suspension aids available and advice should be sought on which to use and how to fit. It is important to ensure that the caravan is towed either level or slightly nose down.

If you have any doubts about the suitability of your towbar for towing a caravan consult the towing bracket manufacturer.

Do not exceed the:

- Gross Vehicle Mass (G.V.M. on car plate).
- Maximum Technically Permissible Laden Mass (M.T.P.L.M.) on the caravan.
- Gross Vehicle Combination Mass (Train Weight) (G.V.C.M. on car plate).
- Maximum Permissible Towing Mass.
- Vertical Static Load on the caravan coupling (noseweight).
- Maximum Vertical Load on the car towball as specified by towing vehicle manufacturer (noseweight).
- Driving licence limitations

STABILITY

Stability

All our models are of a well balanced design and should be exceptionally good towers. The common causes of poor stability include:

- a. Worn springs or loose spring fixings on the towing vehicle.
- b. Towing vehicle springs too soft.
- c. Insufficient nose weight.
- d. Nose of caravan is towing too high or too low.
- e. Unsuitable towing vehicle.

Galvanised steel chassis

Drilling of the galvanised steel chassis will invalidate the warranty and must not be done.

Suitable towing vehicles

The caravan is manufactured for towing behind normal road cars and is not suitable for towing behind commercial vehicles.

It is strongly recommended that whenever a caravan is to be towed over rough terrain, e.g. a field or track, great care should be taken to ensure that no undue stress is placed upon the caravan via the hitch mounting, i.e. reduce speed. If in doubt, please consult the chassis manufacturer and the towing vehicle manufacturer who will advise.

Touring caravans based on standard AL-KO chassis can be towed by four wheel drive off road leisure vehicles providing the unit is used to tow in a like manner to a conventional road-going car and driven in the same considered manner.

Towbar manufacturers should be consulted before towing an uncompensated twin axle caravan.

Snaking

This is a term used to denote an unstable car and caravan combination where the caravan 'weaves' from side to side often causing a similar swaying movement in the car itself.

Causes:

1. Unsuitable or unbalanced outfit.
2. Incorrect loading or weight distribution.
3. Excessive speed especially downhill.
4. Side winds.
5. Overtaking.
6. Being overtaken by a large fast moving vehicle.
7. Erratic driving.
8. Incorrect tyre pressures, car and caravan
9. Incorrect vehicle towball height
10. Worn hitch head or towball

Cures

Cases of persistent snaking can be alleviated by the use of a stabiliser.

On the road

If you do find your outfit snaking, try to keep the steering wheel in a central position as far as possible, decelerate and avoid braking if possible.

Types of tyres fitted

The original tyres fitted by the manufacturer are suitable for towing at a maximum speed of up to 81 mph (130 kph).

Tyres

Caravan manufacturers choose the type, size, profile, load carrying capacities and speed ratings to match the design masses of their vehicles, adjusting the tyre pressures to suit. Only change the type of tyres on your caravan on expert advice from the caravan manufacturer, or tyre manufacturer.

Tyre maintenance

Tread depth

Pay special attention to the amount of tread remaining on your tyres, and measure them regularly. Always replace tyres before they reach the minimum legal limit of 1.6mm. Periodically tyres should be rotated to equalise wear in the same manner as car tyres.

Pressures

The caravan manufacturers plate (fixed adjacent to exterior door) and Technical handbook contains information about caravan loading and the required adjustments to tyre pressures, which should be followed for safety (these pressures relate only to the tyres originally fitted to the caravan). Tyre pressures should always be checked and corrected prior to each journey. It is vital that tyre pressures are maintained at the levels recommended by the manufacturer to ensure maximum tyre life, safety and handling characteristics.

Please also remember to check your spare tyre pressure as it can be easily overlooked.

Over or under-inflating tyres is likely to seriously impair their performance and may compromise the safe use of the vehicle.

Over-inflation increases overall tyre diameter, decreases the amount of tread in contact with the road, decreases sidewall flexibility and affects road-adhesion.

Under-inflation decreases overall tyre diameter, increases sidewall flexing, generates higher tyre operating temperatures and difficult vehicle handling characteristics. Running an under-inflated tyre may cause premature tyre failure. Both over and under-inflation adversely affect tyre life.

Tread

Keep tyre treads clean of stones and other foreign bodies, and check regularly for damage to the tread and sidewalls. It is vitally important that any damage is checked out by a tyre expert and any necessary repairs or replacements are carried out immediately.

Tyre valves

Check tyre valves carefully. Ensure the caps are in place free from dirt/ debris and that there is no evidence of cracking or damage to the valve stem.

Tyre Ageing

Rubber compounds used in tyres contain chemicals that help to slow down the natural aging process of untreated rubber. However, tyres do deteriorate with age, which increases the risk of tyre failure, and there are many ways in which this can be spotted:

- Cracking/crazing on the side wall of the tyre, caused by its flexing
- Distortion of tyre tread
- Deformation of the carcass of the tyre

There will also be a deterioration of the ride quality caused by vibrations through the tyre. This may signify the tyres performance has been affected by age and should be investigated as soon as possible

Note: It is recommended that tyres are replaced after 5 years from the date of first inflation. The date of first inflation is normally within a few days of the date of manufacture of the vehicle they are fitted to, and this date can be determined from the gas and / or electrical certificate supplied with the caravan.

We recommend that tyres that are over 5 years old (from first inflation) are inspected and passed as fit for use by a qualified technician. It is possible that in the event of a tyre failure, an insurer may not cover any losses incurred if the tyre is over 5 years (from first inflation) and was not inspected no more than 12 months prior to the incident.

THE TYRE LAW

Tyres that display signs of aging should be removed and not put to further use.

The effects of aging can be brought about prematurely in several conditions. Tyres fitted as spare wheels may age prematurely. If tyres on caravans are not in regular use they should be inspected before every journey, several cleaning products may also harm the chemicals in the rubber. However, the age of a tyre will affect its safety and increase the risk of failure, and you should inspect tyres for the signs of aging regularly.

Note: The use of some motor movers can damage or increase wear on the tyres prematurely.

The tyre law

Note: Sales literature/ Technical Handbooks publish recommended tyre pressures for the MTPLM only (fully laden condition). It is not possible to publish tyre pressures for any other load condition other than the MTPLM.

Tyre types

It is illegal to mix tyres of a different construction on the same axle.

Note: Although the caravan may be fitted with the same type of tyre as the towing vehicle, the pressures specified are different. All charts show values for cars and are therefore not applicable for caravans.

Pressures displayed on tyre walls apply ONLY in North America and Canada.

Wheels

Caravan wheel bolts supplied with your caravan should be tightened to a torque of 88Nm (65lb/ft) on steel wheels or 130Nm (96lb/ft) on alloy wheels and should be checked with the use of a torque wrench regularly. Only use a spare wheel and tyre of the type and size provided with your caravan.

Note: Please remember to check the wheel bolt torque setting regularly.

Wheel rims

Two sizes of wheel rims are used 5.5J x 14 and 6J x 15, the rim sizes are the same for both steel and alloy rim, incorporating a double safety hump which conforms to European safety standards. Check the size on your caravan before replacing a rim.

Hitch head load capacity

The maximum vertical static load which can be put upon the hitch head when connected is 100kg. Please refer to the technical data in your handbook. (But see also vehicle manufacturer's weight limits on towball loading.)

Hitching-up

An assistant can help in the hitching operation by standing on the left hand side of the drawbar (facing rear of car) and extending an arm horizontally to indicate position of the coupling. When reversing aim the towball of the car directly at the caravan drawbar. Remove towball cover and keep in car.

Adjust the jockey wheel to ensure the hitch head is high enough to slide over the towball.

⚠ WARNING: Do not lift the coupling head by hand when hitching the caravan to the car. Always raise and lower the coupling head by winding the handle on the jockey wheel up and down.

AK161 Type Hitch head

SAFETY 1

Open position

The hand grip points diagonally upwards and indicates to the operator that it is open.



SOFT TOUCH GRIP

(AL-KO registered design)

A soft and therefore adhesive plastic mixture is used in the red area of the hand grip. In addition, the projection on the end of the hand grip serves as an anti-slip protection.



When the towball is not yet fully inserted a red section is displayed.

SAFETY 2

Closed position

The towball is fully inserted and has released the securing lever. (Important! Legally prescribed minimum imposed load is necessary). Only now does the hand grip take up the horizontal position and indicate to the operator that a secure connection has been created. The unit is now ready for towing.

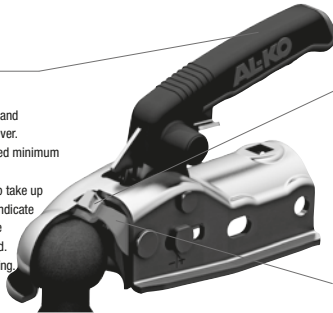

SAFETY 3

Display for correct hitching

In the closed position, the green safety display is pushed out by the ball on the towing vehicle, and is therefore visible. Once again, it signals to the operator that the trailer is securely connected to the towing vehicle. The journey may now start.

Securing lever for flawless hitching

Fig. A

Open the locking mechanism by pulling the coupling handle upward in the direction of the arrow (Fig.A safety 1). The handle will remain in the open position until the hitch head is positioned onto the towball.

Release the caravan handbrake and manoeuvre the hitch head over the **greased towball** and re-apply the handbrake. Using the jockey wheel winding handle, lower the hitch head carefully onto the towball. The pressure of the towball within the hitch head will release the locking tongue with an audible click and the coupling handle should drop down. For safety check that the coupling handle is fully down by pushing the handle down manually. When the hitch head is correctly coupled to the tow ball the green collar of the locking display button will be visible. (Fig A Safety 3). If the green collar is not visible it is not safe to tow the caravan. Contact your dealer for advice.



PRE-TOW CHECK LIST

Pre-Tow Check List

Check gas locker, battery locker and cassette toilet doors are secure.

Check wheelnuts, tyre pressures and tyre conditions.

Fully raise all four corner steadies. (Fig. E & F).



Fig. E



Fig. F

Pick up any levelling pads or levelling boards.

Check windows/rooflights/vents are securely closed.

Ensure television aerial is lowered (where applicable).

Switch off gas supply and change fridge to 12V operation.

Lock the caravan exterior door.

Check all car and caravan roadlights are working.

Check round the caravan for anything left behind.

Fit extending mirrors

Release caravan handbrake, adjust all mirrors from driving seat and proceed.

- All road lights must be in working order.
- Lenses and reflectors must be in good condition
- Bulbs must be of correct wattage for the application (see Service handbook).

⚠ WARNING: Do not cause any road lighting to be obstructed by the addition of any options or accessories to your caravan.

13 Pin socket

Please be aware that some car manufacturers and towbar manufacturers do not wire up all 13 pins as standard, unless requested.

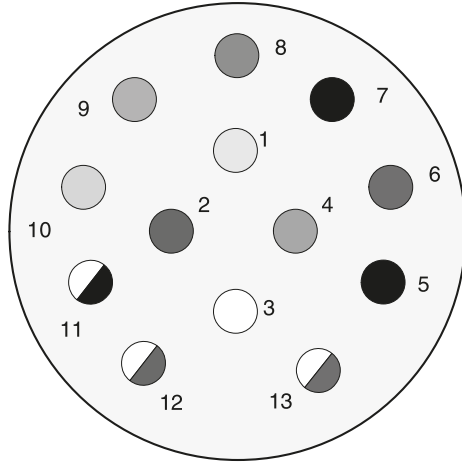

11446 Plug Connector viewed
from cable entry on plug

Pin No	Core Colour	Core Size	Function
1	Yellow	1.5	Left Hand Indicator Light
2	Blue	1.5	Rear Fog Warning Light(s)
3	White	2.5	Earth for pins 1 - 8
4	Green	1.5	Right Hand Indicator Light
5	Brown	1.5	Right Hand Tail Light
6	Red	1.5	Brake Lights
7	Black	1.5	Left Hand Tail Light
8	Pink	1.5	Reverse Light(s)
9	Orange	2.5	Car +ve
10	Slate (Grey)	2.5	Fridge +ve
11	White/Black	2.5	Earth for pin 10
12	White/Blue	1.5	Not Yet Allocated
13	White/Red	2.5	Earth for pin 9

TOW CAR ELECTRICS

Tow Car Electrics

In all cases, The Swift Group assumes that the tow car harness and electrics have been fitted with the specific requirement of connection to a caravan, which may contain AL-KO trailer control (ATC), a 12V powered fridge and charging circuits.

Most modern retro-fit towbars contain a relay, located somewhere within the boot of the tow car, which may have a selectable power output for the fridge supply.

If a customer is experiencing issues with the fridge supply it is possible the relay requires adjustment and they should contact their tow vehicle electrics installer or an auto electrician to verify the installation.

LED Road Lighting

Your caravan maybe fitted with LED road lighting, including the directional indicators and stop lamps. LEDs consume very little power, offer excellent light output and longevity when compared to traditional tungsten bulbs.

Some more advanced tow cars are fitted with Vehicle Light Monitoring Systems {VLM}, where the car monitors the condition of the trailer/caravan road lights and advises the driver of any bulb failures. To do this, some tow cars expect to see a load on the caravan lighting circuit similar to a tungsten bulb while others may send a pulse of energy to each light to confirm that the resistance of a bulb is present.

The result of the above is that some tow cars may incorrectly advise the driver of a bulb failure, due to the use of LED lights while others may flash or pulse the lights during use.

Recognising this, The Swift Group have developed an additional towing fusebox, which when connected to the existing towing fusebox and is used to assist the towcar in recognising the VLM System. Depending on the type of car and system used the fusebox maybe model specific.

The secondary fusebox is chargeable and available through any Swift Group Dealer.

Note: This will change updates will be required.

Caravan 13 Pin Connection - care advice

All caravans since 2008 have been supplied with a 13 pin plug to connect to the towcar. The 13 pin plug has an inner ring assembly that is independent from the outer body.

Plug Inner Ring (containing male pin terminals) - fitted to the caravan

Plug Outer Body with locating groove and hood - fitted to the caravan

Socket Body (containing female socket terminals) - fitted to the car



Under normal circumstances the inner ring and the outer body will be locked in one position (see fig 1).



When the plug is first inserted in the socket body ensure that the locating protrusion (key) matches the groove (keyway) in the socket body. The outer body can then be rotated a full 90 degrees clockwise until a click is felt or heard, at this point the cover flap can be allowed to fall over the circular surface of the plug top.

To remove the plug it is important to rotate the outer body a full 90 degrees anti-clockwise, again until a click is heard or felt before withdrawing the plug from the socket. This will ensure that the inner and outer parts of the plug are returned to a locked condition.

WARNING: If the connector is not fully rotated anti-clockwise prior to removing it from the socket it is possible that the inner ring will become 'floating' and may result in a condition where the protrusion will be incorrectly aligned (see fig 2 & 3).

Fig 2



Incorrect alignment

Fig 3



Incorrect alignment

If this situation does occur then it can be corrected by inserting the edge of the protrusion on the plug into the groove in the socket (see Fig 4) and rotating the plug body anti-clockwise until a click is felt. This process will re-establish the lock between the inner and outer parts allowing the correct insertion of the plug into the socket.

Fig 4



Note: Customers should note that the towbar and towcar electrical socket will be checked as part of the standard MOT regulations, under directive 2009/40/EC. This not only applies to tow cars but also all Motorhomes fitted with a tow bar and socket. Inappropriate repair or modification to either maybe deemed a failure of the vehicle if it is likely to affect the road worthiness of the vehicle.

Passengers

Passengers are forbidden to ride in a caravan.

Breakaway cables

UK law requires that all caravans are fitted with a safety device to provide protection in the unlikely event of separation of the main coupling while in motion. A device referred to as a 'breakaway cable' fulfils this requirement and when fitted as on your caravan is mandatory.

Purpose

To apply the caravans brakes if it becomes separated from its towing vehicle. Having done this, the cable assembly is designed to part allowing the caravan to come to a halt away from the towing vehicle.

Construction

A thin steel cable with a red plastic coating fitted with a means of attachment for connection to the towing vehicle. Located directly beneath the coupling head.

Operation

In the event of the main coupling of the caravan separating from the towing vehicle, the cable should be able to pull tight, without any hindrance, engaging the caravan brakes. The breakaway cable should not become taut during normal driving.

Correct procedure for use

Regularly check the cable and clip for damage. If in doubt contact your Swift Group dealer.

Make sure the cable runs as straight as possible and goes through the cable guide fitted underneath the caravan coupling head.

BREAKAWAY CABLE

Determine whether or not the towing vehicle towbar has a designated attachment point (i.e. a part specifically designated for a breakaway cable).

Where a point is designated on the towbar:

- Either pass the cable through the attachment point and clip it back on itself (Fig 1) or attach it directly to the designated point (Fig 2).

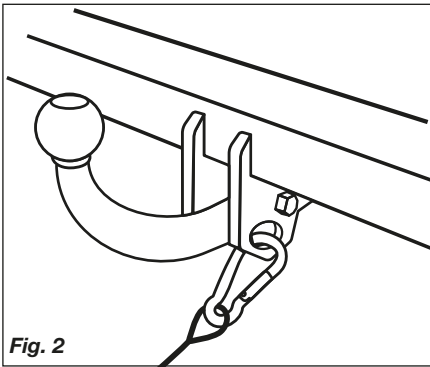
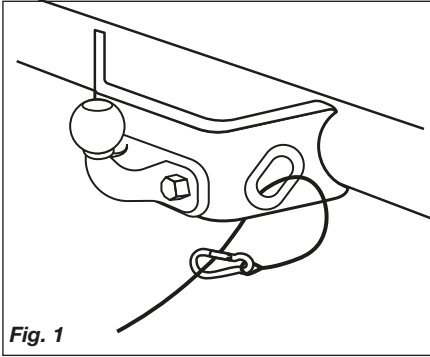

Where there is no designated attachment point on the towbar:

- Fixed ball: Loop the cable around the neck of the towball in a single loop only. See figure 3A and 3B.

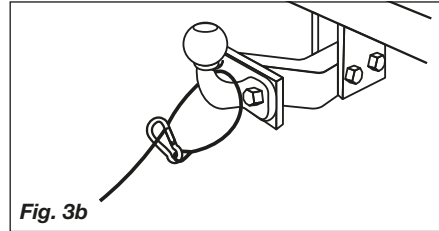
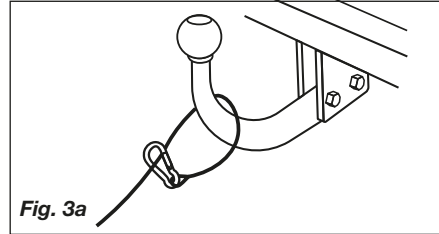

In some instances it may be possible to attach the cable assembly either to a permanent part of the towbar structure, as long as this meets the approval of the towbar manufacturer/supplier, or to an accessory sold for the specific purpose of breakaway cable attachment. For vehicles fitted with detachable towbars, guidance must be sought from the towbar manufacture/supplier on the correct method for attaching the breakaway cable.

When the breakaway cable is attached it must not snag in use on the trailer coupling head, jockey heel or any accessories, e.g. a stabiliser, bumper shield, cycle carrier, etc. There should also be sufficient slack in the cable to allow the towing vehicle and trailer to articulate fully without applying tension to the cable which could otherwise cause the trailer brakes to be inadvertently applied.

The cable must not be allowed to drag on the ground. If there is too much slack, the cable might drag on the ground and be weakened so that it has insufficient strength to apply the brakes in the event of the trailer becoming detached when in motion. Excess slack may also lead to the cable being caught on an obstacle when in motion, leading to inadvertent application of the trailer brakes. Care must be also taken to ensure that the cable cannot be entangled with the electrical cables.

Mirrors

Towing mirrors are mandatory in the UK.

It is essential that exterior towing mirrors are fitted. This is mandatory and drivers can face instant fines if extension mirrors are not fitted.

⚠ WARNING: Any rear view mirror must not project more than 250 mm outside:

- the width of the caravan when being towed.
- the width of the towing vehicle when driven solo.

Note: Any rear view mirror fitted shall be 'e' marked and cover the field of view as stipulated by type approval requirements (Community Directive 2003/97 or ECE Regulation 46.02 or Regulation 33 of the Road Vehicles (Construction & Use Regulation 1986).

Moving off

Let the clutch in smoothly.

Allow more engine speed to produce the power to move the additional weight of the caravan.

Reduce wear and tear on clutch and transmission by taking extra care.

Change gears smoothly.

Try not to jerk the clutch.

Reversing

When the towing vehicle is reversing, the overrun device shaft is pushing in, applying the brakes via the overrun lever, brake rod system, bowden cables and the expander mechanism.

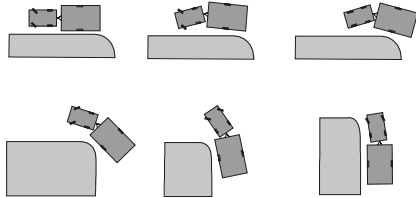

Fig. A Reversing

The backwards rotation of the brake drum causes the secondary brake shoe to collapse cancelling out the braking effect, allowing the caravan to move backwards. At the same time the transmission lever swings back and compensates for the entire travel.

When reversing up a slope or on a loose surface the brakes may apply themselves. Correct maintenance and set up of the brakes will help prevent this. Incorrect adjustment of the wheel brakes or linkages will result in making reversing difficult.

Proficiency at reversing can only be achieved with practice and should be first attempted in a large open area (Fig. A).

Speed limits

Single carriageways: 50mph

Motorways (including dual carriageways): 60mph

CARAVAN HANDLING

Caravan handling

Allow for caravan being wider than car.

Do not bump kerb with caravan wheels.

When passing other vehicles allow more than the normal clearance for driving solo.

Allow longer to build up speed to pass.

Allow for the outfit being twice its normal length.

Do not suddenly swing out.

Carry out all manoeuvres as smoothly as possible.

Use nearside wing mirror to check caravan has cleared when overtaking.

⚠ WARNING: Take care not to foul or ground caravan chassis whilst traversing ramps or other obstacles.

Motorway driving

Important points

1. Caravans may not be towed in the outside lane of a three or four lane motorway. (Reg. 12(2) of the Motorway Traffic [England and Wales] Regulations 1982).
2. Reduce Speed:
 - a. In high or cross winds
 - b. Downhill
 - c. In poor visibility
3. High sided vehicles cause air buffeting so extra care must be taken when passing or being passed. As much space as possible should be given.

Spare wheel

The spare wheel is located in the gas locker at the front of the caravan.

Note: The side-lift jack (when fitted) has a maximum lifting height of 375mm and the scissor jack a maximum lifting height of 340mm.

Changing a wheel

1. Leave caravan hitched to towing vehicle and ensure that the caravan and towing vehicle handbrakes are applied.
2. Lower corner steadies (as safety measure) on the side that is being jacked up.
3. Remove wheel trims (if fitted).
4. Use wheel brace to slacken off wheel nuts on the wheel to be changed.
5. Position jack under the axle at the appropriate jacking point (see Fig. B, page 34)
6. Jack up the caravan until the wheel for removal is just off the ground.
7. Remove the wheel nuts and remove the wheel.
8. Fit spare wheel and reverse the above procedure. Ensure clean, dry mating surfaces and clean, dry bolt/nut sealing areas.
9. Ensure the spare wheel is free from damage and distortion
10. Tighten all five bolts, according to Fig. A, to 88Nm (65lb/ft) for steel wheels or 130Nm (96lb/ft) for alloy wheels using a torque wrench or have checked as soon as possible. Ensure the correct wheel fixings are used, as supplied with your caravan.

⚠ WARNING: When a wheel has been removed and replaced the torque of the wheel nuts should be re-checked after approximately 50 miles.

Wheel bolt tightening

When refitting a wheel it is ESSENTIAL that the wheel bolts are tightened to the recommended torque figure and in the correct sequence.

Note: Only use a suitable wheel brace to loosen and tighten the wheel bolts. Do not use the corner steady brace for this application.

The sequence necessary to correctly carry out this work on a 5 stud wheel is as follows:

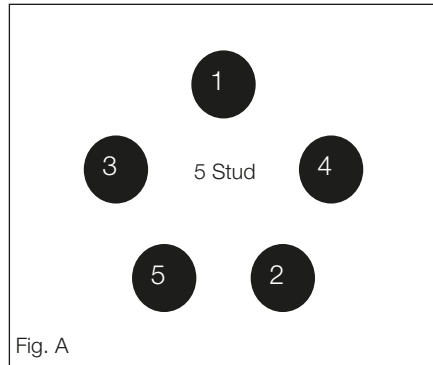

Please note the correct torque settings.

Jacking points

⚠ WARNING: Only jack up your caravan when it is coupled up to the car with its handbrake applied and in 1st gear (engine off).

Ensure that the jack is located in the correct position, i.e. on the jacking bracket on the chassis for the AL-KO side mounted jack (Fig.B) where fitted. Alternatively the reinforced axle mounting plate can be used but the chassis member itself MUST NEVER be used as a jacking point.

All caravans are provided with the facility to fit AL-KO side jacking points although a scissor, trolley or bottle jack may be used.

Ensure the lifting capacity of your jack is suitable for your caravan.

STOPPING ON A HILL



Fig. B Side lift jack

Stopping on a hill

Pulling off again can sometimes present a problem. The easy solution is

1. Carry a good sized wedge shaped piece of wood with a rope or light chain attached.
2. Attach the other end of the rope to the nearside rear grab handle.
3. Place the wood behind the nearside caravan wheel.
4. Carefully reverse the car slightly back down the hill, the caravan will stop against the wedge and turn.
5. Drive forward since this attempt to move up the hill will now not involve pulling the full weight of the caravan until the car has gained some traction.
6. When reaching the top of the hill retrieve the wedge.

Arrival on site

Note: Check and observe site regulations.

Manoeuvring your caravan by hand

Note: Care must be taken when manoeuvring your caravan into position. Pressure placed on unsupported parts of front and rear GRP panels may cause surface damage/ cracks to appear. Use the grab handles provided.

1. Selecting a pitch

Do not pitch in such a position that your outfit will obstruct others coming in.

Try to choose an area which is dry, reasonably level and preferably with a hard base.

If you have no alternative but to pitch on a slope ensure that, for when you leave, you are facing down the slope.

Ensure sufficient space is left at the rear of the caravan (4m) for the awning

It is good practice to chock the wheels of the caravan when parked on a slope even though the caravan brakes are applied.

2. Levelling the caravan

Levelling must be carried out in both directions in order for the refrigerator and other equipment to function correctly. This should be done before unhitching the caravan. Levelling boards (Fig. C) can be used to raise one side of the caravan by driving or reversing the caravan onto the boards. Apply the handbrake and chock the wheels.

The positioning of the jockey wheel can be used to help level the caravan.

Lower the corner steadies until they are in firm contact with the ground.

⚠ WARNING: DO NOT use the steadies as a jack they are only a means of stabilising the caravan.

Levelling pads or boards should be used under the steadies where the ground is soft or uneven.

In extreme cases where it is necessary to raise a wheel off the ground for levelling purposes, further adequate support should be applied so that the steadies do not take any undue strain.



Fig. C Levelling board

Exterior door

To prevent distortion of the body, the caravan must be always correctly sited and levelled. Failure to site the caravan correctly may prevent the exterior door from closing properly.

3. Unhitching

Before applying the handbrake ensure the hitch is fully extended and not compressed behind the tow vehicle otherwise the hitch will not release from the tow ball.

Apply the caravan handbrake.

Lower the jockey wheel to the ground.

Disconnect the breakaway cable and road lighting plugs.

AK161

Lift the coupling handle to release the locking tongue (page 25), whilst simultaneously winding down the jockey wheel, to lift the caravan hitch head clear of the tow ball.

Fire	38
Smoke Alarm Operation	38
Fire extinguisher	38
Escape paths	38
Children	38
CO Alarm - Fireangel CO-9D Carbon Monoxide Alarm operation.....	38
Ventilation	39
Security	39
Swift Command tracker.....	40
AL-KO Secure immobiliser.....	41
Mobile Alarm System	42

FIRE / SMOKE ALARM / CO ALARM

Fire

Important: Your attention is drawn to the notice affixed inside the caravan wardrobe advising on fire precaution, ventilation and what to do in case of fire.

In case of fire

1. Get everyone out of the caravan as quickly as possible using whichever exit is the quickest, including windows. Do not stop to collect any personal items.
2. Raise the Alarm. Call the Fire Brigade.
3. Turn off the gas supply valve if it is safe to do so.
4. Turn off the electricity supply at supply point.

Smoke Alarm operation

Your caravan is fitted with a Fire Angel SB1 smoke alarm. Please read the user instructions for the smoke alarm, which are available at the following location:

<http://fireangel.co.uk/products/sb1-t>



If you are unable to view the documents online, please contact the supplier, your dealer or Swift for an electronic or paper copy.

⚠ WARNING: Never use portable cooking or heating equipment other than electric heaters that are not of the direct radiant type as it is a fire and asphyxiation hazard.

⚠ WARNING: Appliances such as cookers must not be used for heating.

Fire Extinguisher

It is recommended that a dry powder fire extinguisher be carried inside your caravan at all times.

When using a dry powder extinguisher it is suggested that the caravan be evacuated until the powder has settled, to avoid inhalation.

A fat pan fire should not have a fire extinguisher aimed at it. It should be smothered with a fire blanket.

⚠ WARNING: Provide one dry powder fire extinguisher of an approved type or complying with EN 3-7 or ISO7165, of at least 1kg capacity, by the main exterior door and a fire blanket next to the cooker. Familiarise yourself with the instructions on your fire extinguisher and the local fire precaution arrangements.

Escape paths

It is important that you do not block escape paths to emergency exits with obstructions or hazards.

Children

Do not leave children alone in the caravan in any event. Keep potentially dangerous items out of reach, as at home e.g. matches, medicine etc.

CO alarm

Fireangel CO-9D Carbon Monoxide Alarm

Your caravan is fitted with a Fireangel CO-9D Carbon Monoxide Alarm. Please read the instructions for the alarm, which are available at the following location:

<http://fireangel.co.uk/wp-content/uploads/2015/07/CO-9D%20Manual.pdf>



If you are unable to view the documents online, please contact the supplier, your dealer or Swift for an electronic or paper copy.

Ventilation

All caravans comply with BS EN 721. The ventilation points on your caravan are fixed points of ventilation which are required by the European Standards.

All caravans have ventilation at high level and low level which have been calculated to suit the individual needs of your caravan.

High level ventilation is achieved by means of the roof lights and washroom roof ventilators. The low level ventilators are positioned underneath the oven housing.

Under no circumstances must these vents be blocked or obstructed in any manner as this could lead to insufficient fresh air. In this case the confined atmosphere becomes depleted of oxygen which could lead to dangerous levels of carbon dioxide (CO₂) build up leading to risk of asphyxiation.

The risks of carbon monoxide (CO) build up, which is a colourless, odourless and tasteless gas, will also be reduced with ventilation. Carbon monoxide is produced from incomplete combustion and should the CO detector be activated the cause of the incomplete combustion must be investigated prior to reusing the appliance in question.

It is advised that fixed ventilation points are checked and cleaned (if necessary) on a regular basis using a small brush and a domestic vacuum cleaner.

Additional night time ventilation is obtained by releasing the window catches and placing them in the second groove. Note the windows are not sealed from rain in this position. As the ventilation levels are calculated to suit each models requirements there should be no modifications made which may result in reduced ventilation levels.

 **WARNING:** Do not obstruct ventilation

Petrol/Diesel Fumes

The fitting of a tail pipe extension to your car exhaust will reduce the possibility of fumes entering your caravan through the ventilation points.

Security

Caravan theft

The theft of a caravan can occur in the most unlikely circumstances; from a motorway service area, even from an owner's driveway.

Secure all windows and doors when your caravan is unoccupied even if only for a short length of time.

Security chips

A special security chip is concealed within the body of every caravan. This chip contains the individual identity of your caravan and can only be read using a special decoder by police officers.

Chassis number

Your 17 digit serial number chassis number can be found on your windows and on the offside chassis member of the drawbar. It is also stated on the manufacturers weight plate next to the doorway.

Make a note of this number in the space provided at the front of this handbook and make a separate note of the number to keep safe at home.

Additional security

Consider fitting any device which might deter or prevent intrusion by thieves.

A hitch lock cover prevents towing of the caravan.

A wheel lock prevents towing of the caravan and removal of the wheel.

Customers are advised to identify their caravan with a method for subsequent identification if other forms of identification have been altered or removed.

Free crime prevention advice about securing your caravan, protecting your valuables, property marking, either at home or whilst on site, can be obtained from the Crime Prevention Officer through your local Police Station.

SWIFT COMMAND TRACKER

Caravan insurance

It is recommended that the caravan and its contents should be insured against theft.

It is essential to check with your car insurance company to ensure you are covered when towing your caravan.

Swift Command Tracker by Sargent

A Swift Command Tracker is built in to your vehicle and forms part of the Swift Command system.

The unit is Thatcham Category 6 certified and is monitored by an approved monitoring centre which operates 24 hours a day 7 days a week and provides European coverage and direct police liaison.

This system is ready for use, all you need to do is purchase a tracking subscription by visiting www.swiftcommand.co.uk or calling Sargent on 01482 881655.

The subscription cost is £95 per year including VAT.

For more information please visit www.swiftcommand.co.uk

Operation

The Swift Command Tracker is easy to operate as it is controlled by the vehicle systems.

In a caravan the tracker is armed when the Stinger 310 / 350 Alarm System is armed. It is disarmed when the alarm is disarmed.

If the caravan doesn't have an alarm system fitted, a simple numeric keypad is used to arm / disarm the tracker. Enter your code followed by the ON button to arm the tracker.

Enter your code followed by the OFF button to disarm the tracker.

Event of a Theft

If the vehicle is moved whilst the tracker is armed the geo-fence monitoring will trigger a theft event.

In addition to the above, in a caravan with the Stinger 310 / 350 Alarm System fitted, if the alarm is triggered by internal movement or caravan tilting the alarm monitoring will also trigger a theft event.

The monitoring station will now contact you to confirm the theft or false alarm. You will be required to confirm your identity against the information you provided when you subscribed.

If a genuine theft is confirmed the monitoring station will liaise with the police and keep you informed of progress.

Note; during a theft event to comply with legislation you will not be able to manually locate your vehicle using the Swift Command locate feature.

Contact

Before contacting any of the following please ensure you know your caravan serial number. For caravans this is the last 10 digits of the CRIS number (like SWG0123456).

The Swift Command Tracker monitoring station can be contacted on 0345 6027302. The stations operates 24 hours a day 7 days a week.

Sargent customer support can be contacted on 01482 678981 or via support@swiftcommand.co.uk

Telephone lines are manned during normal office hours.

Swift customer support can be contacted on 01482 875740 during normal office hours.

cont...

Precautions

The Swift Command Tracker monitors the leisure battery supply and if the voltage falls below a set level or the battery is removed this will trigger a fault event.

If you plan to remove your battery for maintenance or external charging please contact the monitoring station BEFORE removing the battery.

If you lose an alarm key fob you need to contact Sargent for a replacement and follow their instructions to remove the 'lost' fob from the system.

AL-KO Secure immobiliser

The AL-KO immobiliser is optional on Base-camp and is not compatible with steel wheels. The secure wheel lock is specific to the 'Edge' alloy wheel fitted. The Secure kit is Swift Part number 9841856 and ALKO number 1559417.

The 4 part kit will contain:

Part A

Box containing security components, consisting of:

- 1 off High security locking bolt.
- 1 off High security locking bar socket key.
- 1 off Barrel lock.
- 2 off Barrel lock keys.
- Instruction manuals in CD and paper format.
- Security registration card and reference number.

Part B

Wheel specific insert assembly consisting of:

- Red coloured wheel insert lozenge assembled with the locking bar and clip.

Part C

- 1 off Wheel spanner.

Part D

- Kit bag.

You must register your key within one month of the date of purchase. Should you fail to do this, you will not be able to order a spare key!

- Within your AL-KO kit you will find an exclusive security number.
- Please register your card by telephoning 0870 7576788 or 0044 1926 818500.

**Safety information
(AL-KO Secure)**

- Always secure the caravan against rolling away (chock or couple to a towing vehicle).
- Always remove AL-KO Secure before moving the caravan.
- After any attempt of theft has been made on a locked AL-KO Secure, the caravan must be inspected at an AL-KO Approved Service Workshop.
- Always keep the key in a safe place.
- Keep the lock set and registration card separate from the key.
- The lock parts and key do not have a registration number, therefore keep the registration card in a safe place.
- Caravans with twin axles have two locks, keep each lock set in a separate place.

The sets are not interchangeable!

AL-KO JACK / MOBILE ALARM SYSTEM

AL-KO operating instructions

- Read the AL-KO operating instructions and act in accordance with them.
- Follow all safety instructions as well as the warning information.
- It is recommended for ease of fit that a side-lift jack be used.
- Keep the operating instructions

The AL-KO side lift jack

(Supplied as standard on specific models only).

The AL-KO Side Lift Jack has been specifically developed to aid the often difficult process of changing a wheel on caravans. It is suitable for fitment to the AL-KO chassis, located in the pre-drilled holes in the longitudinal members.

Note: The fitment of some aftermarket motor movers may inhibit the use of the AL-KO jacking system. Contact AL-KO for alternative location.

Mobile alarm system

Depending on specification, your caravan may be fitted with a Sargent AS310 Stinger Alarm System. Please read the instructions for the alarm, which are available at:

<https://sargentltd.co.uk/tech-support/article/Alarm-Manuals/21>



If you are unable to view the documents online, please contact the supplier, your dealer or Swift for an electronic or paper copy.

Water System.....	44
Plumbing connections	46
Plumbing troubleshooting	47
Pressure switch adjustment.....	48
Sanitising water system	48
Water Fault Finding.....	50
Typical gas schematic drawing	52
Gas	53
Types of gas	54
Gas safety advice	54
Awning space ventilation	55
Changing a gas cylinder	55
Gas Fault Finding	57
Electrical system	58
Overseas connection	58
13 Pin tow vehicle connections	59
230V mains electrical equipment power consumption	60
Wiring of connecting cable and caravan mains inlet	61
Typical appliance consumption figures	62

WATER SYSTEM

Water system- Introduction

All Swift Group caravans water systems have been designed around a pump fitted within the caravan. This pump draws water from an external source, to provide water pressure within the caravan, whenever it is switched on and water is available.

The schematic below shows the basic configuration of the water system with inboard pump and no internal water tank:

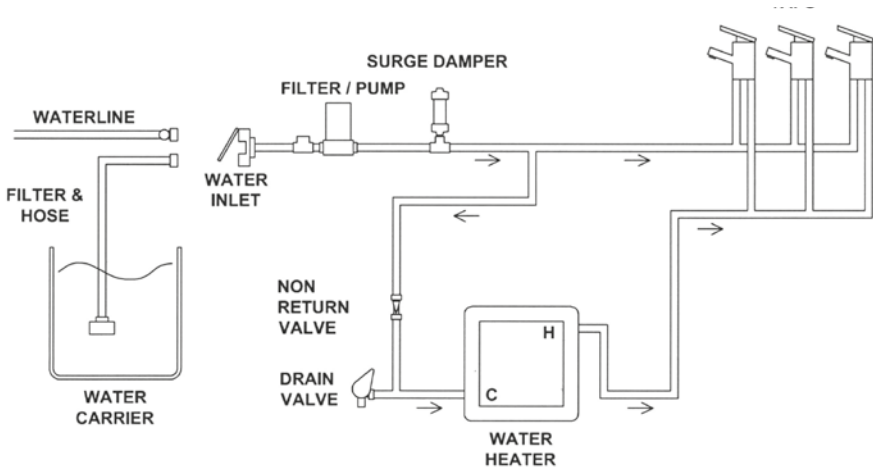

When power is supplied to the pump, it will draw water from the external container through the water inlet mounted on the side of the caravan, and pump it to the caravan taps, shower and water heater.

The pump is fitted with its own pressure switch, and the pump will continue to pump water, until the pressure of water on the output of the pump reaches a pre-set level. For this pressure to be achieved, the taps must be closed.

When the taps are opened, water will leave the tap via the spout, and the pressure in the pipes between the pump and the taps will reduce. Because of this reduction in pressure, the pressure switch on the pump will switch back on and the pump will again run to pump more water.

Close to the pump, the water under pressure is split into two paths:

1. Through blue water pipes routed directly to the cold connection of each tap.
2. To the water heater.

Water from the pump enters the bottom of the water heater. Once the water fills the water heater (approx 8.5 litres), water then leaves the water heater via a connection at the top of that water heater. This water, which is still under pressure, then routes to the hot connection of each tap via red pipes.

On Arrival at the campsite / Priming the system

- Ensure that the external water container is full. An umbilical hose with baffle is supplied with your caravan to connect between the inlet and aqua roll or similar container.
- Close all of the taps (kitchen sink, bathroom, shower) except one, which should be open in the hot position.
- Ensure that the water heater drain valve is closed (move the Yellow handle on the floor near the water heater to a horizontal position).
- Switch the pump on using the button on the control panel. Water will flow through the open tap after a short time. This tap can then be moved to the cold position and again after a short time water will flow.
- Repeat the procedure at each tap, including the external shower point (model specific)
- When using a mains water connection the pump will still need to be switched on to supply water to the water heater, taps and shower.
- If a mains water connection is used, please ensure this is a Whale Watermaster mains water hook-up, which has a built in pressure reducing valve.
- To drain / winterise the system please see separate details later in this handbook.

Whale Water In Socket and Watermaster® exterior water pump with Easi-Push Plug (when fitted)



To use the water inlet:

- 1) Fill an external water container, and position the container near the Whale water inlet on the side of the caravan.
- 2) Slide the lid upwards, by gripping the sides of the lid, as shown on the image below:

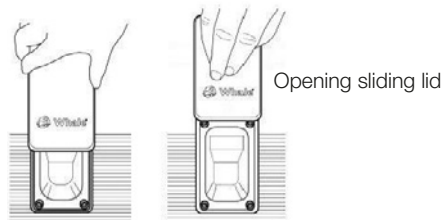

- 3) Place the hose and filter supplied with the caravan, into a full water container
- 4) Insert plug into water inlet and slide lid down to lock plug in place as shown in the image below:

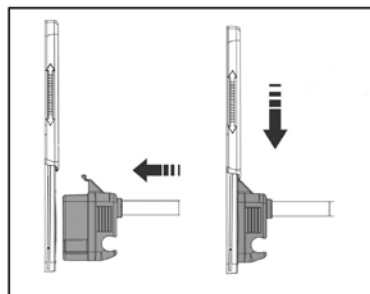

PLUMBING CONNECTIONS

- 5) Adjust dust cover over opening in water container as shown in image below. Please note dust cover should not be secured to water container, as air must be allowed to enter the container to replace the water being pumped out.

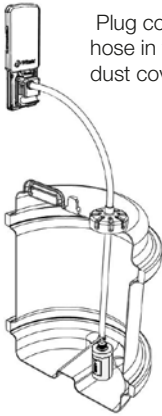

Plug connector to inlet, with hose in water container, and dust cover in place

Slide lid up to unlock and remove plug. When removing the plug, simply pull the plug clear of the socket using the hand grip.

Please note: It is recommended that you change your Whale water filter every 3000 litres or after approximately 30 days of use as smells and debris will build up in the filter and effect the pump's performance. No other maintenance is required.

WARNING: This filter cartridge should not be used in water supplies of an unknown bacteriological quality. This is not a bacterial filter.

Plumbing Connections

In most cases, speed fittings are used, which allow easy and quick connection of water pipes.

To connect a pipe to a fitting, simply push the pipe into the connector. To remove the pipe, push the collar of the fitting inwards, and then withdraw the pipe.

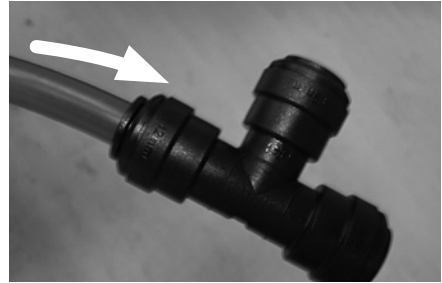

To connect a pipe, simply push the pipe into the connector.

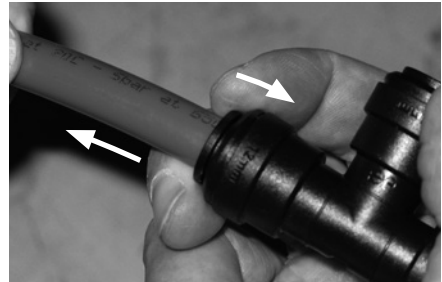

To remove a pipe, push the collar inwards, and then remove the pipe.

As a note, when refitting the pipe, ensure the end of the pipe is round (not oval) and the cut is square. If not, it could lead to water leaks.

Troubleshooting

Pump will not start, when the tap is opened:

- Check fuse(s).
- Check power source(s), and ensure there is sufficient voltage to run the pump.
- Ensure 'pump' LED is illuminated.
- Using a multi-meter, ensure there is power at the pump. If not, refer to your dealer as there maybe damaged cabling or a fault with the fusebox.
- Is the pump hot? If so, allow to cool before retrying.
- Has the vehicle been stored over winter? Was it correctly winterised? If no, the pump may have frozen, causing permanent damage.
- The pressure switch may need adjusting. See page 48 on how to do this.

Pump runs, but will not pressurise system (i.e. no or little water being discharged from taps) - Not Pulsing:

- Ensure water in source is present (onboard tank or aqua roll).
- Check in-line pump filter is free from debris and correctly fitted.
- Ensure water system has been primed correctly, (see page 45) and there are no airlocks present.
- Ensure there are no restrictions in the plumbing.
- Using a multi-meter, ensure there is power at the pump. If not, refer to your dealer as there maybe damaged cabling or a fault with the fusebox.
- Ensure the inlet side of the pump (including Whale inlet and in-line filter) are watertight and not allowing air into the system.
- Check (using a multi-meter) that the voltage at the pump is between 10v-14.5v.

Pump continues to run (for more than 5 seconds) after taps are closed or pump turns on for no reason:

- Check for leaks on the high pressure side of the pump.
- Ensure water system has been primed correctly, (see page 45) and there are no airlocks present.
- Ensure the pump is securely mounted.
- Ensure the piping on the high pressure side of the pump is in good condition (not blowing or deforming).
- The pressure switch may need adjusting. See page 48 for information on how to do this.

Noisy or rough operation

- Check for leaks on the high pressure and low pressure side of the pump.
- Ensure that all pipes (especially those within 150mm of the pump) are not touching any furniture.
- Ensure the pump is securely mounted.

Pump rapidly cycles (switches on or off) or water pulses from taps, including temperature pulsing:

- Check for leaks on the high pressure and low pressure side of the pump.
- Ensure there are no restrictions in the plumbing
- The pressure switch may need adjusting. See page 48 for information on how to do this.

WATER SYSTEM

Water pump pressure switch

The purpose of a pressure switch is to monitor the pressure on the outlet side of the pump. When a tap is closed, and the pump continues to run, there is an increase of pressure in the system, and when that pressure reaches a pre-set limit, the pressure switch will turn the pump off.

Water pump pressure switch adjustment

Pressure Switch Adjustment, Truma/Flo-Jet pump. (Normally Grey upper section with White lower section/valve housing)

- All of the Truma/Flo-Jet pumps used by Swift are pre-set at 25psi - 31psi.
- To further adjust the pressure switch setting, a cover cap must be first be removed from the end of the pump to reveal a pressure adjusting screw, as shown in the photos. A maximum of 1/4 turn clockwise or anti-clockwise, from the factory setting, is advised. Turning the screw clockwise 1/4 turn will increase the pressure switch cut-out pressure, turning the screw anti-clockwise will reduce the pressure setting.
- Please note a second screw mounted below the cover cap is set in position with threadlock, this should not be disturbed.

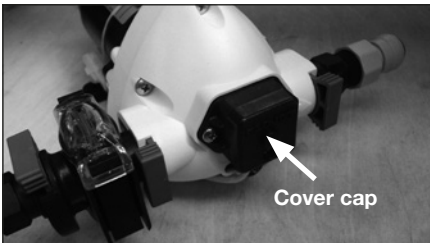

Cover cap

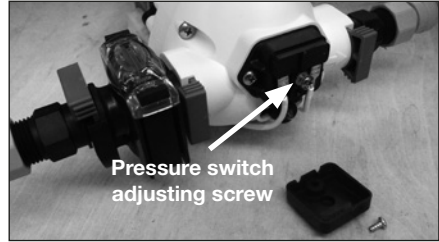

Pressure switch adjusting screw

Sanitising

Guidance on cleaning portable water tanks and the water system in touring caravans.

The water systems, and in particular water tanks, in caravans are susceptible to contamination by bacteria if care is not taken with their use and cleaning. The symptoms caused by bacterial contamination are not purely limited to gastro-intestinal diseases, but may also manifest themselves as ear, nose, throat, eye or skin infections. It is therefore important that you carry out the following procedure prior to using the caravan each time, even if you boil or filter all water you use for drinking.

Separate Water Containers

1. All water remaining in the container should be disposed of so that the container is empty.
2. The outside of the container should be thoroughly cleansed and washed down to remove any dirt, dust or other contaminant. Water at a suitably hot temperature containing an appropriate detergent is recommended for this purpose.
3. Water should be put in the container, swirled around, then emptied out.
4. The container should then be totally filled with water containing an appropriate sterilant solution and allowed to stand for the recommended contact time.
5. The solution should be emptied from the container.
6. The opening of the container should be cleaned thoroughly with an appropriate prepared wipe impregnated with a sterilant.

7. The container should be inverted whilst stored overnight (if possible).
8. The container must be filled with mains water only and mains water only should be used for the above cleaning procedure.
9. On no account should garden hoses be used to fill water tanks.

For Systems:

1. Drain down the system (open all taps to allow air in, enabling the system to drain quickly).
2. Remove any after market water filters fitted, and replace with a short length of hose or empty filter cartridge (this will ensure the filter is not affected by the disinfectant/sterilant solution).
3. Fill the system by using the pump with a disinfectant/sterilant solution (check that the solution at full strength appears at all taps/showers). Allow to stand for the recommended period of time.
4. Drain the system completely.
5. Thoroughly clean the outside of all taps/connectors with a cloth soaked in the disinfectant/sterilant.
6. Flush the system through with clean drinking water until no traces of disinfectant/sterilant can be detected at any tap.
7. Replace the filter.

Suitable sterilising chemicals are available from your caravan dealer, accessory shop, chemist or home-brew shops. It is not, however, recommended to use bleach or sodium metabisulphite.

Do not use products that contain aggressive agents for sterilising the water system.

NOTE: Never use the water heating system when disinfectant/sterilising fluid is present. Doing so may damage the system.

WATER FAULTS

Water

Fault	Cause	Remedy
Water not flowing from any tap when operated but pump runs	<p>Freshwater tank empty</p> <p>Pump wired in reverse</p> <p>Pipe inlet or outlet pipe disconnected</p> <p>Pump pipes restricted by kinking</p> <p>Blockage in pump inlet or outlet pipe</p> <p>Blocked in-line filter of pump filter</p> <p>Air leak in suction line to pump</p>	<p>Check</p> <p>Check wiring, refer to pump manufacturers instructions</p> <p>Check connections</p> <p>Check pipes run</p> <p>Check, starting inside freshwater tank</p> <p>Dismantle and clean</p> <p>Check for bubbles.</p>
Pump does not run	<p>Pump or tap incorrectly wired</p> <p>Pump fuse blown</p> <p>Battery disconnected</p> <p>Pump seized or overheated</p> <p>Pressure pump sensing switch may have failed</p> <p>Contacts may be faulty</p> <p>Wiring connections may be faulty</p>	<p>Refer to pump/tap manufacturers instructions</p> <p>Check wiring connection and then replace with fuse of correct rating</p> <p>Check connections</p> <p>Refer to pump manufacturers servicing instructions</p> <p>Refer to pump manufacturers servicing instructions</p> <p>Check contacts in plug and socket are clean and making contact</p> <p>Check wiring connections</p>
Water flows from cold tap but not from hot	<p>Feed pipe to water heater incorrectly connected to the heater outlet</p> <p>Blockage in hot pipeline</p> <p>Heater inlet or outlet pipes kinked preventing flow</p> <p>Hot tap not connected</p> <p>Hot tap failed or blocked</p> <p>Heater non-return valve jammed</p>	<p>Refer to installation instructions</p> <p>Disconnect pipes and inspect.</p> <p>Check and re-route if necessary.</p> <p>Check pipe and connect where required.</p> <p>Disconnect and inspect.</p> <p>Refer to dealer.</p>

Water

Fault	Cause	Remedy
Water flows from hot tap but has reduced flow from cold	Cold water pipe kinked preventing flow Blockage in cold pipe line Cold tap not connected Cold tap failed or blocked	Check and re-route if necessary Disconnect pipes after 1st connector and check up to tap Refer to installation instructions Disconnect and inspect
Reduced flow from both hot and cold taps	Battery condition low causing pump to run slowly If new taps have been fitted they may be restricting flow Pump needs servicing Partially blocked pump filter or in-line filter, if fitted Pump outlet pipe kinked restricting flow Water leak	Check battery state of charge, refer to electrical supply note Disconnect and check that they have at least 1/4" (6.3mm) bore Refer to pump servicing instructions Dismantle and clean if necessary Check and re-route if necessary Check all water connections
Reduced flow from either tap	Pipe kinking restricting flow	Check and re-route if necessary
If pump motor runs steadily and will not stop	Battery voltage may be too low (below 10.5 volts) Pressure Switch setting problem	Check that there is water in the container Adjust switch and/or re-charge battery Check all connections in pipework. Adjust settings.

Gas schematic

GAS SCHEMATIC

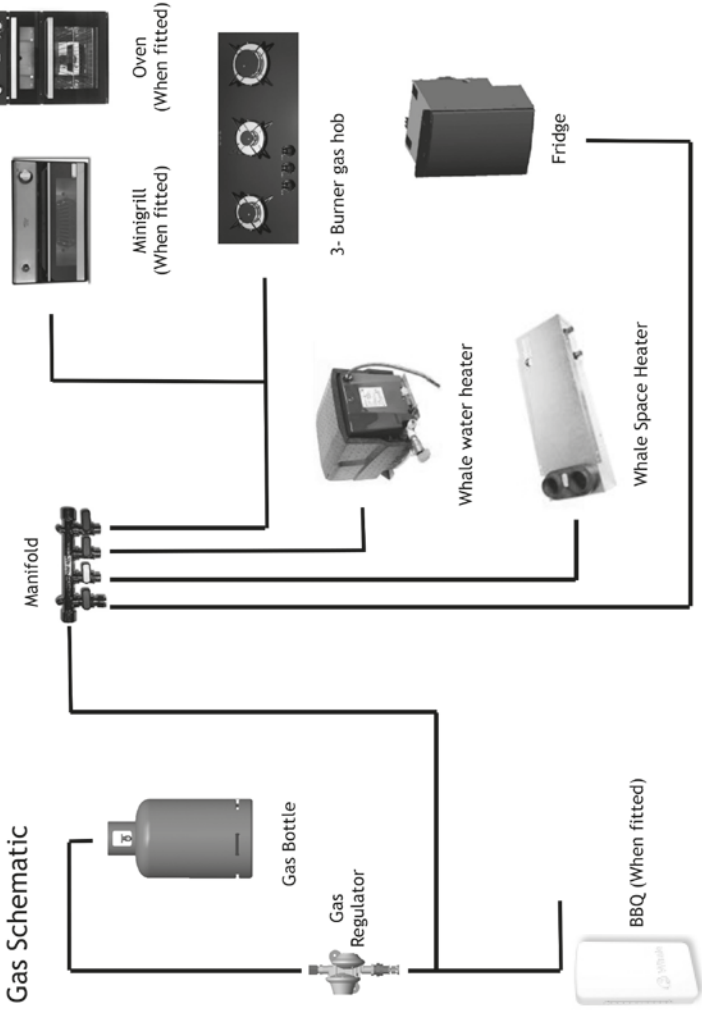

Gas

General information

Gas Cylinders

Bottled Liquefied Petroleum Gas (LPG) is the most convenient portable source of fuel for your caravan. Make sure that heating and cooking appliances and the gas cylinders are switched off before you move the caravan.

Regularly check flexible gas hose, joints and connections for tightness.

Finally make sure that each gas appliance is working efficiently to the recommendations of the appliance manufacturers.

Only use gas bottle cylinders that are located within their dedicated position within the front gas bottle housing, never extend hose - hose lengths must not exceed 400mm.

Gas Hoses

A high pressure hose must be used with the regulator to connect to the gas bottle.

LPG cylinders i.e. Propane, Butane and Camping Gaz cylinders all have varying cylinder adaptor connections. It is important to check you have the correct hose and adaptor to suit your gas cylinders. Push on hoses are no longer permitted under the new regulations, The new high-pressure hoses have threaded connections and must be securely attached to the regulator and to the gas cylinder.

The pressure regulator relies upon a sealing washer(s) to maintain a gas tight joint, and it is essential to check that the washer is present, sound and correctly positioned prior to making the connection. The gas cylinder connection relies on a metal seating or bull nose connection to obtain a gas tight joint, therefore it is essential that the mating surfaces are clean and undamaged. In no case should a damaged valve or connection be used.

Ensure that there is a constant rise in the flexible gas hose between the gas cylinder outlet and the regulator elbow.

⚠ WARNING: Inspect flexible gas hose(s) regularly for deterioration and renew as necessary with the approved type, in any case no later than 5 years after the date of manufacture marked on the hose.

⚠ WARNING: Ensure hoses do not become entangled in door mechanism.

Cylinder compartment

All cylinder compartments have two universal plastic mouldings fitted to the floor of the compartment that are designed to fit both steel and BP Gas Light cylinders and two universal support cradles with straps for retaining the bodies of the cylinders at mid to high level and two universal support cradles with straps for retaining the bodies of the cylinders at mid to high level.

⚠ WARNING: Ensure that the hose assembly is not under stress when connected to the cylinder.

Regulators

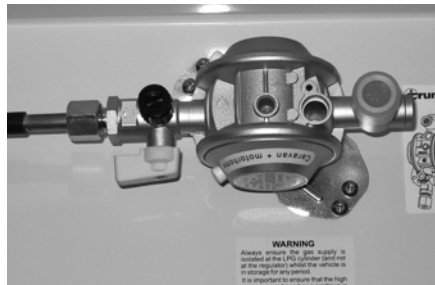

Your caravan is supplied with a wall mounted gas regulator plumbed inside the gas cylinder compartment. The regulator and all appliances work at a harmonised 30mb pressure, which work with Butane and Propane gas.

Pressure regulation system in this vehicle has a fixed working pressure of 30 mbar with a flow rate of 1.5 kg/h and complies with the requirements of EN 12864 annex D.

Note: Regulator valves and cylinder valves should always be in the 'OFF' position when towing and storage.

GAS

⚠ WARNING: When leaving the caravan for any period of time or storage always turn off the gas at the gas cylinder.

Note: Never allow modifications or repairs of electrical or LPG systems and appliances except by qualified persons.

⚠ WARNING: Isolate cylinders when re-fuelling

General

Regularly check flexible gas hose, joints and connections for tightness. Finally make sure that each gas appliance is working efficiently to the recommendations of the appliance manufacturers.

The LPG system should be inspected annually by a competent person.

Only use gas cylinders that are located within their dedicated position within the gas bottle housing, never extend the hose - hose lengths must not exceed 400mm.

We do not recommend the use of an inline LPG BBQ with the regulator when other LPG appliances are in use.

⚠ WARNING: The LPG cylinder valve should be closed when driving.

Types of gas

Propane

Propane is supplied in red, or partly red bottles which have a female left hand threaded connector.

Scandinavian countries use the same connector.

Germany and Austria supply propane with a male connection.

Propane will work at temperatures as low as -40°C and is therefore suitable for all winter caravanning.

NOTE: We recommended the use of 6kg Calorlite Propane bottles.

Butane

Butane is supplied in the U.K. in green or blue cylinder.

All these have a male left hand thread

EXCEPT for Camping Gaz which has a special female right hand thread and Calor 7kg and 15kg and aluminium cylinders which have a special clip-on connection.

Continental cylinders usually have a male left hand thread similar to but not identical with U.K. butane.

Butane is only suitable for use at temperatures down to 2°C and will not work below that.

Gas safety advice

⚠ WARNING: If you smell gas or suspect a leak or in the event of a fire and if it is safe to do so, isolate the gas appliances and turn off the gas bottles at the regulator. Evacuate the caravan and ventilate. Seek professional advice as to the cause of the leak.

Facts about LPG

- LPG is not poisonous.
- Bi-products are harmless.
- There is danger if all air and oxygen were excluded.
- (Ventilation holes must be kept clear at all times).
- LPG has been given a smell by the manufacturers in order to identify leaks.

Awning Spaces LPG Appliance Exhaust

There is no danger of pollution of an enclosed awning space by the LPG exhaust from a refrigerator venting into it, as awning spaces are generally well ventilated.

Space heaters may produce sufficient exhaust to pollute the awning space, if it is totally enclosed, from a general comfort, smell and hygiene point of view. In the extreme case there could be a build up of carbon dioxide to a dangerous level.

Caravan owners are advised to allow some fresh air circulation in the awning space when such appliances are in use.

Precautions

- a. Never look for a leak with a flame. Always use a soap solution or its equivalent when testing connections. Do not operate any electrical apparatus whatsoever, especially light switches. If the leak is not obvious, the caravan should be evacuated and qualified personnel consulted.
- b. Avoid naked lights when connecting or changing a cylinder.
- c. Check the flexible hose frequently.
- d. The gas is heavier than air and therefore sinks to the lowest point.
- e. Keep bottle gas containers outside (and protected against frost). If they must be kept inside make sure they are well away from heat.

⚠ WARNING: Do not use appliances with a different working pressure to 30mbar.

⚠ WARNING: Maintain adequate spacing of combustible materials from sources of heat.

⚠ WARNING: Do not use independent portable gas appliances inside the vehicle. Cookers shall not be used as heaters

⚠ WARNING: A BBQ point inlet valve, if fitted, must only be used for the connection of portable LPG appliances.

⚠ WARNING: Always read individual appliance instructions

⚠ WARNING: IF IN DOUBT ASK

Changing a gas cylinder

Please use the correct size spanner for the gas hose connectors as this will prevent damage to the screw fittings and ensure that the fitting is tightened sufficiently.

- Turn off gas appliances
- Close the empty gas cylinder's valve
- Remove the high pressure hose from the gas cylinder.
- Attach the high pressure hose to the full gas cylinder.
- Open the full cylinder's valve.
- Press the hose-break safety device.

Check the hose connection to the cylinder valve for leaks

Ensure that the gas regulator hose is correctly connected to the gas cylinder in gas bottle compartment and that the hose connection is tight.

Gas bottles must be fully located, seated at the base of the bottles and restrained by the strap provided in the dedicated compartment position. Straps are positioned to suit 6kg Calor Lite cylinders.

⚠ WARNING: If using cylinders other than those recommended, the user must ensure these are adequately supported, ventilation openings must not be obstructed and the cylinders must not cause damage to other fixtures and fittings located in the compartment.

Open ended gas hoses must always be protected from dirt and insects.

Before turning on the gas supply at the regulator, ensure that all gas operated equipment in the caravan is turned off.

All gas equipment (except barbecue and some water heaters) is supplied through a central Gas Manifold System which

GAS

has individual isolation taps for each appliance (Fig A), as follows:

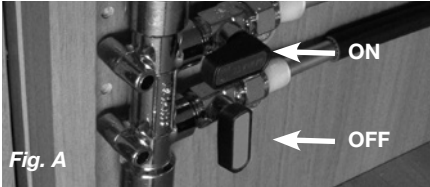

- Fig. A**
- WHITE -Space Heater
 - BLUE -Fridge
 - GREEN - Oven
 - RED - Water Heater

Note: the external barbecue point (when fitted) is fed from the main feed through a built in integrated isolation valve. See schematic layout for details.

Flue installations

All flue installations should be inspected once a year throughout their length for corrosion. Flues should be replaced if any sign of perforation is found. Ensure that the replacement is of an approved type and fitted by a qualified and competent person.

Thermal insulation heating

Your caravan has been designed and manufactured to a grade 3 thermal insulation and heating level for specific climatic conditions and tested according to the procedure in EN1645-1.

The classifications are as follows:

Grade 1

A caravan with an average thermal transmittance (u) that does not exceed $1.7w/(m2k)$.

Grade 2

A caravan with an average thermal transmittance (u) that does not exceed $1.7w/(m2k)$ and which can achieve an average temperature difference of at least $20^{\circ}C$ between inside and outside temperatures when the outside temperature is $0^{\circ}C$.

Grade 3

A caravan with an average thermal transmittance (u) that does not exceed $1.2w/(m2k)$ and which can achieve an average temperature difference of at least $35^{\circ}C$ between inside and outside temperatures when the outside temperature is $-15^{\circ}C$.

GAS

Fault	Cause	Remedy
Hob does not light	No gas	Check level of gas in the cylinder Check gas cylinder valve is on Check gas taps are on
	Air in pipe	Purge system Refer to hob manufacturers instructions
Oven does not light	No gas	Check level of gas in the cylinder Check gas cylinder valve is on Check gas taps are on
	Air in pipe	Purge system Refer to oven manufacturers instructions
Heating appliance will not light	No gas	Check level of gas in cylinder Check gas cylinder valve is on Check gas taps are on Check exhaust outlet is clear
	Over gassed Air in pipe	Turn off appliance, wait 2 minutes and try again Purge system Refer to space heater or boiler manufacturers instructions
Fridge does not light	No gas	Check level of gas in the cylinder Check gas cylinder valve is on Check gas taps are on
	Air in pipe	Purge system Refer to fridge manufacturers instructions

ELECTRICAL SYSTEM

The electrical system

General Information

It is strongly advised that the mains installation is inspected periodically to ensure safe use. The IET (BS7671) wiring regulations recommend that mains installations in touring caravans are re-inspected every 3 years. The National Caravan Council lists the qualifications necessary to perform this inspection, but an NICEIC approved contractor is probably the first choice.

On arrival at the campsite

- Disconnect hitch and 13 pin plug from the towing vehicle.
- Place the 13 pin plug in the holder provided to prevent damage.

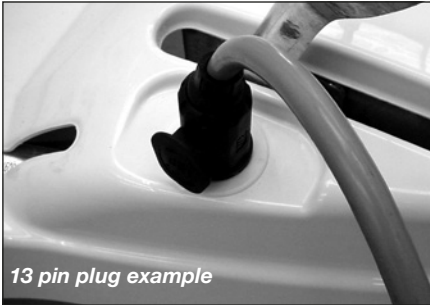

- Check the suitability of the supply, is it AC or DC, is the voltage and frequency correct.
- Ensure that there is a proper earth (3 pin socket outlet).
- If in doubt consult site staff.
- Make sure that the supply from the site is switched off.
- Make sure that the charger switch on the PSU is switched off.
- Lift the cover on the electricity inlet on the caravan, and insert the connector on the flexible supply cable.
- At the site supply point, connect the other end of the supply cable to this using the socket provided.
- Switch on the main switch at the site supply point.

Care point: It is good practice to test the RCD (Residual Current Device) in the PSU before switching on. There is a test button on the RCD to test the lever, put the lever in the up position (on) before testing.

Care point: As with the RCD it is good practice to check the Miniature Circuit Breaker (MCB) in the PSU. Switch all to the on position (lever up). If any do not stay up then there is a fault.

On departure from the campsite

- Switch off supply from the site, disconnect the cable at both ends.
- Switch off RCD.

⚠ WARNING: Current consumption in the caravan must not exceed 16 amps or the pitch permitted maximum if this is less than 16 amps.

Overseas connection

- Connection to a mains voltage overseas requires particular attention.
- Overseas supplies can be of reverse polarity.
- Reverse polarity results in equipment not necessarily being isolated when turned off, reverse polarity indicator on the PSU will light in the event of reverse polarity.
- The only sure way to make equipment safe is to unplug it.
- It is useful to have a means of checking polarity when overseas.
- If it can be achieved then connect live to live, and neutral to neutral to achieve full electrical protection.

⚠ WARNING: Never allow modifications or repairs of electrical or LPG systems and appliances except by qualified persons.

13 pin connection

When using the 13 pin connector system for the first time it is worth taking a few minutes to familiarise yourself with the basic features of the connectors.

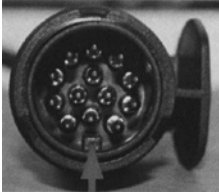

Fig. 1 - Correct alignment

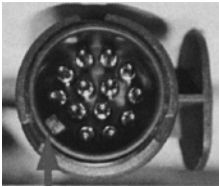

Fig. 2 - Incorrect alignment

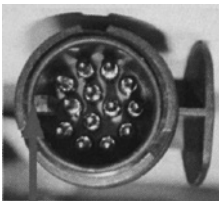

Fig. 3 - Incorrect alignment



Fig. 4 - Alignment marks

The important difference with the new 13 pin plug, when compared to the old 12N/S type, is that the plug has an inner ring assembly that is independent from the outer body. Under normal circumstances the inner ring and the outer body will be locked in one position (see fig 1).

When the plug is first inserted in the socket body ensure that the locating protrusion (key) matches the groove (keyway) in the socket body. The outer body can then rotated a full 90

degrees clockwise until a click is felt or heard, at this point the cover flap can be allowed to fall over the circular surface of the plug top (figs 6 & 7).

To remove the plug it is important to rotate the outer body a full 90 degrees anti-clockwise, again until a click is heard or felt before withdrawing the plug from the socket. This will ensure that the inner and outer parts of the plug are returned to a locked condition.

If the connector is not fully rotated anti-clockwise prior to removing it from the socket it is possible that the inner ring will become 'floating' and may result in a condition where the protrusion will be incorrectly aligned (see fig 2 & 3).

If this situation does occur then it can be corrected by inserting the edge of the protrusion on the plug into the groove in the socket (fig 8) and rotating the plug anti-clockwise until a click is felt. This process will re-establish the lock between the inner and outer parts allowing the correct insertion of the plug into the socket.



Fig. 5 - Socket body (containing female socket terminals) fitted to the car

13 PIN CONNECTION

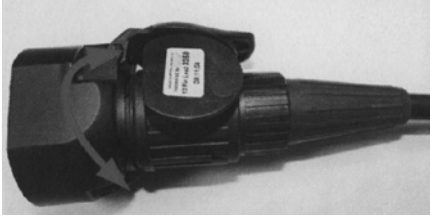

Fig. 6



Fig. 7



Fig. 8

Plug inner ring
(containing
male pin
terminals fitted
to the caravan)

Plug outer
body with locating
groove and hood
fitted to the
caravan)

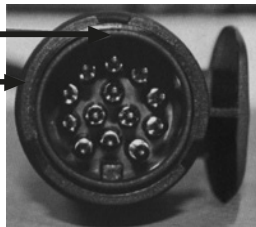

Fig.9

230V mains electrical equipment power consumption

Note: It is possible that the 230v mains electrical equipment may not all operate simultaneously. A typical UK site mains hook up point provides a maximum output of 10 amps and on some continental sites the available output may be as low as 5 amps. If your loading exceeds the site supply it may trip the site circuit breaker. Please check the available mains supply with your site operator.

Similarly loadings on each circuit breaker within the caravan should be observed.

A label positioned close to the MCB's (Miniature Circuit Breakers) will identify which appliances within the caravan are fed from which MCB. Consulting the typical appliance consumption figures table in conjunction with this label, will give an indication of which appliances can, and cannot, (site supply allowing), be operated simultaneously.

WIRING OF CONNECTING CABLES AND CARAVAN MAINS INLET

Wiring of connecting cable and caravan mains inlet

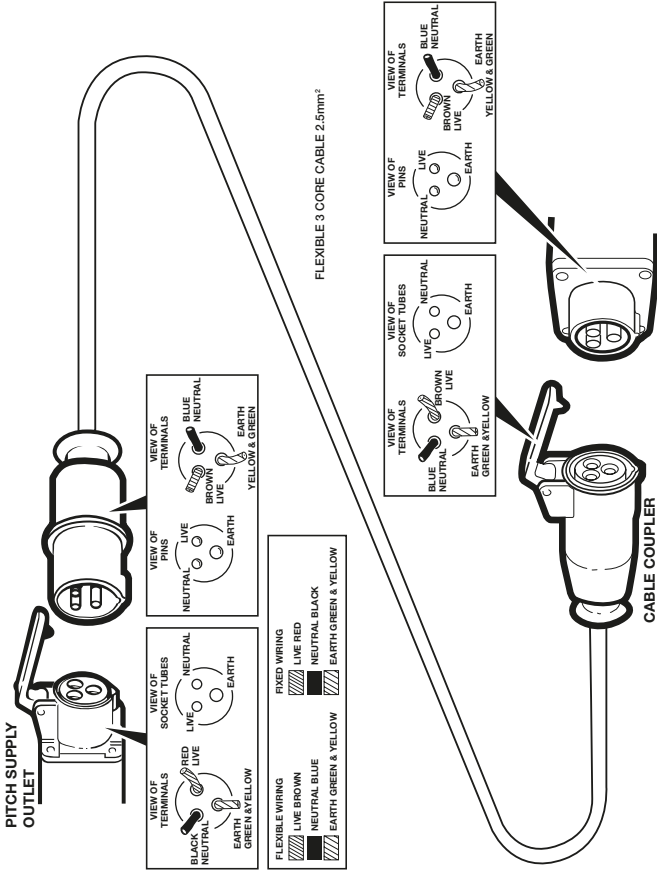

The legal length of the mains inlet cable is 25 ± 2 metres. When in use it must be fully uncoiled and protected from traffic.

TYPICAL APPLIANCE CONSUMPTION FIGURES

Typical appliance consumption figures

Appliance/ Item	230 Volt		12 Volt		LP Gas grams/hour
	Watts	Amperes	Watts	Amperes	
Domestic Refrigerator	190 W	0.8 amp	Only when driving		16 g/h
Whale Space Heater	500 / 1000 / 2000 W	2.2 / 4.4 / 8.7 amp	20 W - 26.4 W	1.7 - 2.2 amp	150 g/h
Whale Water Heater	600 / 1200 W	2.6 / 5.2 amp	4 W	0.36 amp	g/h
Hob burners	Not applicable		Not applicable		70 - 161 g/h
Grill	Not applicable		Not applicable		117 g/h
Battery Charger	690 W	3.0 amp	Not applicable		Not applicable
Omnivent	Not applicable		2 w - 8.6 w	0.2 - 7.2 amp	Not applicable
12V LED Lights (each, depending on size of light)	Not applicable		0.4W - 6.1W	0.05 - 0.5 amp	Not applicable
Pressure switched water pump	Not applicable		48 W	4.0 amp	Not applicable

Note: These are approximate figures for guidance only, and are subject to changes in specification. The figures show energy consumption when an item or appliance is operating – i.e. a light is illuminated, or a heating system is providing space heating or water heating. Appliances which feature LCD or illuminated control panels can have a low current consumption when in stand by mode, or have a constant low current draw in the background to run their displays and electronic systems - these figures are typically 0.4 amps or less, for each applicable item. These electronic items can in most cases be switched off individually, or, use of the System Shutdown button on the power supply unit isolates all of these items.

Swift Command Power Control System	64
Control Panel Operation	66
Bluetooth pairing	76
System warnings	77
Residual Current Device & Miniature circuit breakers	79
Generator usage	79
Battery charger	80
Leisure Battery	80
12 Volt DC Fuses	82
Electrical fault table	84
Remote access and control	87
Battery	90
Solar panel connection point	91
Generator usage	92
Habitation relay	93
Exterior 230v socket	93

SWIFT COMMAND POWER CONTROL SYSTEM

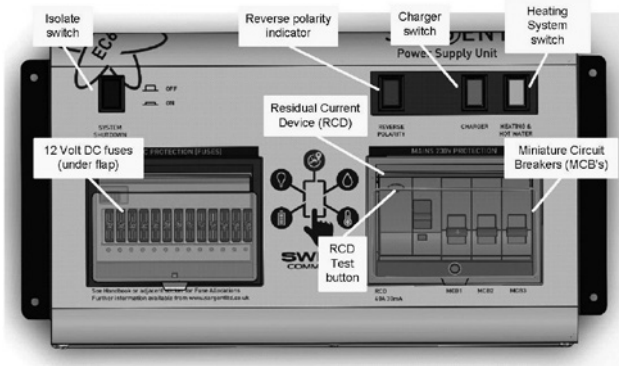

1. Introduction

This section of the handbook will guide you through the operation of the electrical system. All details are correct at the time of going to press. Please also see the online version which will include any later updates or amendments.

Further technical details are contained in section 3 or in the supporting technical manual available from www.sargentitld.co.uk

For the safe operation of all electrical equipment within your Leisure Vehicle it is important that you read and fully understand these instructions. If you are unsure of any point please contact your dealer / distributor for advice before use.

The system has a number of key components that you will need to be familiar with before attempting to use the system, these are:

- The EC601, EC602 Power Supply Unit (PSU)
 - a combined mains consumer unit and 12V controller usually located in a storage area (lower bed box, wardrobe or similar).
- The EC800 Control Panel (CP)
 - a remotely located user control panel used to turn circuits on and off and to display battery, water tank and other system information. This panel uses graphical touchscreen with straightforward controls and reliable data communication to the PSU.
- The PX300 Intelligent Battery charger 300W.

- The C44+ Road Light Fuse Box
 - This small unit is located in the front bed box. The unit houses fuses for the road lighting circuits and supplies from the tow vehicle, and also has connectors for the optional alarm system and Automatic Trailer Control (ATC) unit.

2. Using the System

2.1 Power Supply Unit - Component Layout (see image above)

The PSU is located in the front offside bed box area.

2.2 Activating the System

The system has a shutdown feature that can be used when the vehicle is in storage. This allows the leisure electronics to be turned off when not required to save battery power. When in the off state the alarm and tracking system supplies are still active, all other supplies are turned off.

Before using the system please ensure the system shutdown switch is in the on position (button in) the system is now active.

Note: If you plan to use the Swift Command remote features the system needs to be active.

2.3 Connecting to the Mains 230V supply and Safety checks

For your safety it is IMPORTANT that you follow these connections instructions each time your Leisure Vehicle is connected to a mains supply. This section assumes that the system is complete and that a Leisure battery has been installed (see 3.4).

A) Ensure suitability of the Mains Supply.

Your Leisure Vehicle should only be connected to an approved supply that meets the requirements of BS7671 or relevant harmonised standards. In most cases the site warden will hold information regarding suitability of supply. If using a generator you also need to comply with the requirements / instructions supplied with the generator. Please note that some electronic generators may not be compatible with your leisure system. Further generator operational information is contained in section 3.2

B) Switch the PSU Battery Charger / Power Converter OFF.

Locate the green 'Charger' power switch on the PSU and ensure the switch is in the off position (button out) before connection to the mains supply.

C) Connect the Hook-up Lead.

Firstly connect the supplied hook-up lead (orange cable with blue connectors) to the Leisure Vehicle and then connect to the mains supply.

D) Check Residual Current Device operation

Locate the RCD within the PSU and ensure the RCD is switched on (lever in up position). Press the 'Test' button and confirm that the RCD turns off (lever in down position). Switch the RCD back to the on position (lever in up position). If the test button failed to operate the RCD see section 3.1.

E) Check Miniature Circuit Breakers

Locate the MCB's within the PSU (adjacent to the RCD) and ensure they are all in the on (up) position. If any MCB's fail to 'latch' in the on position see section 3.1.

F) Turn the PSU ON.

Locate the black 'Shutdown' button and ensure it is in the on position (press button in). Locate the green 'Charger' switch on the PSU and turn to the on position (press button in). The charger switch will illuminate when turned on.

G) Check correct Polarity.

Locate the 'Reverse polarity' indicator on the PSU and ensure that the indicator is NOT illuminated. If the indicator is illuminated see section 3.2

H) Check operation of equipment.

It is now safe to operate the 12V and 230V equipment.

2.4 Operation while driving

The power control system is designed to shutdown parts of the system while the engine is running. This is to meet Electro Magnetic Compatibility (EMC) regulations and to ensure the safe operation of the caravan. With the engine running the screen will show a warning 'ENGINE RUNNING'.

Please ensure the system shutdown switch on the PSU is in the on (button in) position before driving (see 2.2). This will ensure the electronic system is active and will therefore be able to control the charging process, supply the refrigerator and monitor other system circuits.

Some caravans may also be specified with en-route heating which will also remain operational while the engine is running.





SWIFT COMMAND POWER CONTROL SYSTEM

2.5 Control Panel - EC800 Layout







Your control panel will have an appearance as below, but depending on your specification of the vehicle the control panel features will vary. Not all features are present in all vehicles.



2.6 Control Panel - Key Features

	<p>'Swift' Power Button. Press the 'Swift' power button to turn the leisure power on, the panel will beep twice and show the Swift start-up logo. The control panel screen will illuminate when the power is on, but the screen will go to sleep after a pre-determined time. Pressing the power button or touching the screen while the screen is asleep will wake the screen without turning the power on or off. To turn the power off press and hold the power button to turn the power off, the panel will beep once.</p>
	<p>Pump Button. Press the pump button to turn the water pump on. Press the button again to turn the pump off. The button border will illuminate when the pump is on. To view the water tank levels and other controls press the water button.</p>
	<p>Awning Light Button. Press the awning light button to turn the awning light on or off. The border of the button will illuminate when the awning light is on. Note the awning light may also be controlled by the caravan alarm system.</p>
	<p>Lighting Button. Press the lighting button to show the lighting control screen. Here you can turn on / off or adjust the dimmable lighting levels. Press the home button to return to the main screen.</p>

SWIFT COMMAND POWER CONTROL SYSTEM

	<p>Power Button. Press the power button to show the power information and control screen. Here you can view battery levels, view charger and solar current and press the more button (right arrow) to view 230V current. Press the home button to return to the main screen.</p>
	<p>Water Button. Press the water button to show the water tank information and control screen. Here you can view tank levels and control related features. Press the home button to return to the main screen.</p>
	<p>Heating Button. Press the heating button to show the heating control screen. Here you can control the heating system, select energy and temperature and by pressing the more button (right arrow) you can set related timers. Press the home button to return to the main screen.</p>
	<p>Radio Button. Press the radio button to show the radio control screen. Depending on specification you can select FM radio, DAB radio or Aux input. Use the buttons on screen to scan, tune or adjust the volume. Press the more button (right arrow) to access the audio settings. Use the additional slider controls to adjust the levels. Press the home button to return to the main screen.</p>
	<p>Air-Conditioning Button. Press the Aircon button to show the aircon control screen. Here you can select the operating mode, set the target temperature and adjust the fan speed. Press the home button to return to the main screen. Note: this button will only be visible if a CI-Bus equipped air conditioner is installed, connected and enabled within the system.</p>
	<p>Settings Button. Press the settings button to show the general settings screen. Here you can set the date & time, screen brightness and screen on time. There are also buttons on this screen to pair a Bluetooth device, delete Bluetooth devices, or turn the key beep on / off. Press the home button to return to the main screen.</p>

SWIFT COMMAND POWER CONTROL SYSTEM

2.7 Control Panel 'Header' Information

At the top of the control panel screen there is a header or information bar which remains visible on all screens. This is designed to provide quick reference information available at all times

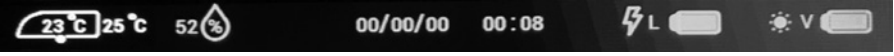

Internal and external temperature in degrees Celsius	Relative humidity range 1 to 100%	Current date	Current time	*Leisure battery status	*Vehicle battery status
The internal temperature is shown inside the vehicle symbol.				Green = good, Orange = fair, Red = poor. Lightning symbol indicates charging from the 230V battery charger.	Green = good, Orange = fair, Red = poor. Sun symbol indicates charging from the solar panel.

*When a battery is not being charged a % remaining figure will be displayed.

This figure is calculated from the battery voltage and therefore should be used for guidance only.

2.8 Temperature Readings

The EC800 system uses two sensors to measure internal temperature and humidity, and external temperature. The internal temperature and humidity sensor is furniture mounted within the caravan, and the external sensor is mounted below the caravan floor. The figures displayed are for information only, and it is hoped the information will be useful, for example when checking temperatures remotely during cold weather.

For vehicles fitted with Alde or Truma heating systems, this sensor is not used to control the heating temperature as it is measured above the door by the Alde or Truma room sensor. The readings on the heating system may vary relative to the one shown on the EC800 control panel.

For vehicles fitted with a Whale heating system, the sensor is used to control the heating temperature as this system does not have its own sensor.

2.9 Water System Operation

The EC800 control panel pump button operates the internal water pump drawing water from an on-board tank if fitted, or an external container when no tank is fitted.

The system incorporates an automatic tank fill feature. When turned on this will automatically fill the on-board water tank from the external container and will switch off automatically when full. To enable tank fill, select 'Fill Tank' on' on the control panel Water screen. To ensure the external pump is not damaged if the external tank runs dry, the pump runs for a maximum of 7 minutes.

The water tank incorporates a level warning feature to warn the user when the fresh water level drops below 25% or when the waste water level reaches 100%. These warnings can be enabled / disabled on the control panel water screen.

If the water pump power is turned on and the fresh water level drops to below 25% a warning beep will be heard and a message will be displayed on the control panel. To cancel the warning, press the confirm button.

These warnings will not be repeated unless the water pump power switch is turned off and on again. This is to ensure the warning does not become a nuisance.

Water Tank Screen

Here you can view the on-board water tank levels and control water tank related features.



Fill Tank

Press the tank fill button to turn on / off the filling of the on-board water tank from the external water container. The pump will turn off automatically when the onboard tank is full or after 7 minutes have elapsed.

Level Alerts

Press the level alerts button turn on / off the water tank empty warning.

Frost Alerts

Press the frost alerts button turn on / off the frost warnings.

2.10 Lighting & Dimming Operation

The system contains up to two dimming channels for groups of lights which can be dimmed, turned on and turned off by this screen, and can also be turned on and off by furniture mounted switches.

The awning light can be controlled by a number of items within the caravan, the local switch adjacent to the entry door (if fitted), the alarm system lighting button, the control panel awning light button and the App. Each item can toggle the light on or off.

The Swift Command App can be used to both configure and adjust the lighting and dimming.

Lighting Screen

Here you can turn on / off or adjust the dimmable lighting levels.



On / Off

Press the centre of either dial to turn the dimmer channel on or off. In the off state the centre of the dial shows the word OFF. In the on state the level value is shown.

Up/ Down

Press the (+) or (-) buttons to increase or decrease the dimming level.

SWIFT COMMAND POWER CONTROL SYSTEM

2.11 Solar Charge Management

The EC601/602/652/653 PSU incorporates a built-in solar charge management feature, which will monitor the input from a separate solar panel and regulator. The Solar Active symbol will be displayed on the control panel when there is an amount of energy available to charge the battery.

The voltage and current produced from the regulator can be viewed on the control panel display by selecting the Power menu item.

Power Screen (12V)

Here you can view battery levels, view charger and solar current and press the more button (right arrow) to view 230V current.



Selected Battery

Use the selected battery button to select which battery you wish to use or charge with the 230V charger. The vehicle battery will only be available when the caravan is plugged into the car.

230V Charging

If a battery is being charged by the 230V charger a 'lightning' symbol will be shown below the dial and adjacent to the relevant battery in the header area.

Solar Charging

If a battery is being charged by the solar panel a 'sun' symbol will be shown below the dial and adjacent to the relevant battery in the header area.

Leisure Dial

The leisure dial shows the voltage of the leisure battery. Press the centre of the dial to change to showing the leisure battery current (+ positive value is charging and - negative value is discharging)

Vehicle Dial

The vehicle dial shows the voltage of the vehicle battery (when connected). Press the centre of the dial to change to showing the vehicle battery current (+ positive value is charging and - negative value is discharging)

Solar Dial

The solar dial shows the current being supplied to the system from the solar panel (if fitted).

2.12 AC Current Limiter Operation

The power control system features a 230V current monitoring system which allows the mains hook up current to be displayed on the control panel. The resolution of this reading is 0.5A. A current limit setting can be activated which if reached will switch off the electric elements in the heating system (and air-conditioning if fitted and enabled), until such time as the current drops and the elements will be switched back on.

An example of this is if a kettle was to be operated whilst the heating was on and the current limit was reached then the heater electric element would be temporarily switched off, when the kettle had boiled then the heater element would be switched back on automatically.

This feature is particularly useful when abroad on a low current supply. Setting the value to OFF will disable this feature.

Power screen (230V)

Here you can view the 230V current and set the 230V current limiter.



AC Current

The dial on the left shows the 230V AC current being used by the vehicle (from the site hook-up).

Set Limit

Press the centre of the dial to turn the AC current limiter on or off. Press the (+) or (-) buttons to increase or decrease the limit level. When on, the system will monitor the incoming AC current and if the set limit is reached the 230V heating element within the heating system will be temporarily turned off until the current falls below the set limit.

Note: For this feature to work correctly the Heating mode must be set to Timer so that the system can control the heating appliance.

2.13 Heating Controls

There are a number of heating systems that can be controlled by the power control system. The system will be preconfigured by the manufacturer or supplying dealer. The related control panel screens are shown below.

Heating screen

Here you can control the heating system, select energy and temperature and by pressing the more button (right arrow) you can set related timers.



Mode

Set the mode to Manual to use the controls supplied by the heating appliance manufacturer. Set the mode to Timer to control the appliance by the EC800 control panel.

Note: The mode will automatically change to App when you control the appliance by the Swift Command app.

Status Temp Water

The status box shows you which timer is currently active, and the temp and water boxes show the target room temperature and water heater setting for the active timer.

Override

When operating in timer mode you can temporarily 'override' the timer room temperature by using the override feature. Press the centre of the dial to turn the override on / off. Press the (+) or (-) buttons to increase or decrease the required temperature.

SWIFT COMMAND POWER CONTROL SYSTEM

Note: You can also override the room temperature by making a change using the appliance control panel (Alde & Truma only). If you make a change the override will automatically activate. The override temperature will continue until the next timer event time.

Truma CP+ Energy



Truma CP+ Energy

The energy, gas or electric setting will vary depending on the appliance type.

For Truma Combi+ heating press the energy button to step through the available settings. Gas is indicated by the flame symbol and electric indicated by the lightning symbol. Possible combinations are GAS, MIX1, MIX2, EL1 or EL2. One electric symbol=1KW and two=2KW.

Alde 3020 Gas / Electric



Alde 3020 Gas / Electric

For Alde 3020 heating system press the gas button to enable or disable the use of gas. Press the electric button to step through the available electric settings. Gas is indicated by the flame symbol and electric indicated by the lightning symbol. Possible combinations are electric OFF, 1KW, 2KW or 3KW and gas ON or OFF. One electric symbol=1KW, two=2KW and three=3KW.

Whale Air Heater & Water Heater



Whale Air Heater & Water Heater

For Whale air and water heating press the air or water energy buttons to select the required energy source for the relevant appliance. Gas is indicated by the flame symbol and electric indicated by the lightning symbol. You can select a mix of gas and electric for the water heater.

Possible combinations for the water heater are OFF, GAS, EL1, EL2, MIX1 or MIX2 and for the air heater are OFF, FAN, GAS, EL1, EL2 or EL3. See the Whale user manual for power ratings for each setting..

Note: Changes made on the EC800 control panel may not be accepted on the heating controller immediately if the controller has been recently used and still has its backlight on. Please try to use one controller at a time.

Heating timer screen

On the heating screen press the more button (right arrow) to set or view the daily heating timers.



Timer

Press on the hour or minute value to change the setting. Timers should be set in order during the day (Timer 1 the earliest and Timer 4 the latest) and use the 24 hour clock.

Temperature

Press the temperature values to change the setting. Each press will increment the value from Off, then 5 degrees through to 30 degrees Celsius.

Water

Press the water values to change the setting. Each press will step through the available setting, which vary by appliance type.

For Truma CP+ available settings are Off, Eco or Hot.

For Alde 3020 available settings are Off, Normal or Boost.

For Whale available settings are Off or On.

Note: To use these timer settings the Heating mode must be set to Timer so that the system can control the heating appliance.

2.14 Air-conditioning

If your vehicle has been fitted with a compatible air-conditioning unit then the settings can be set / controlled by the EC800 control panel, the air-conditioner infrared remote control or the Swift Command app. The unit must be turned on with its power switch before it can be controlled.

The related control panel screens are shown below. For information in using the air-conditioning from the Swift Command app, please see the Swift Command User Guide.

Air-conditioning screen

Here you can select the operating mode, set the target temperature and adjust the fan speed.



Lights

Press the lights button to control the LED light built into the air-conditioning unit. Select on or off to turn the light on or off, or select dimmed to allow the light to be controlled with other dimmable lighting in the vehicle.

Mode

Press mode button to select the required operating mode. Select off to turn the air-conditioner off. Note that available modes vary according to the model of air-conditioner fitted.

Temperature

Use the temperature setting (+) or (-) buttons to increase or decrease the temperature setting. Available settings range from 5 degrees to 30 degrees Celsius.

Fan Speed

Use the fan speed setting (+) or (-) buttons to increase or decrease the fan setting.

Note that available settings vary according to the model of air-conditioner fitted.

SWIFT COMMAND POWER CONTROL SYSTEM

2.15 DAB / FM Radio (not fitted as standard)

Radio screen

Here you can select the radio mode, scan for stations, tune or adjust the volume.



Mode

Press the mode button to select the required radio mode, available choices vary by specification and include FM, DAB, Aux 3.5mm input or Off. Select Off to turn the radio off.

Scan

Press the (<) or (>) buttons to scan forward for the next station or to scan backwards for the previous station.

Tune

Press the (+) or (-) buttons to increase or decrease tuned frequency.

Note: Aux can be used when a device is connected to the radio module using the 3.5mm jack plug, either on the side of the radio module or on the binnacle at the front of the caravan (depends on model specification).

Set the device volume to a mid-setting and then adjust on the EC800 control panel. If the sound level is too low increase the device volume, or if the sound is distorting reduce the level.



Volume

Press the (+) or (-) buttons to increase or decrease the volume level. Press on the centre of the dial to mute the volume, press again to restore the volume level.

Preset

The 5 pre-set buttons are used to store and retrieve your favourite stations. To store a station, firstly scan or tune to the required station, then press and hold the pre-set number until you hear a beep. To retrieve a station simply press the required pre-set button.

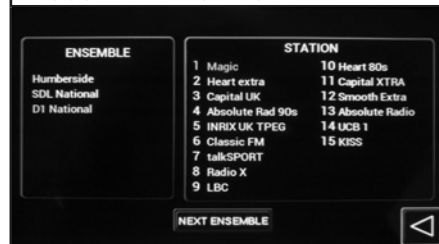

DAB Channel List

When using the DAB radio, the channels are grouped into ensembles. You can scan for channels within an ensemble by pressing the (<) or (>) button.

You can also press on the central channel information window to show a full list of ensembles and their channels. Press the next ensemble button to scan for channels in the next available ensemble.

You can select an ensemble by pressing on it in the left side list. You can select a station by pressing on it in the right side list. Press the < button to return to the radio screen.

Note: DAB reception may be temporarily interrupted by poor signal or when using electrically 'noisy' equipment or appliances (for instance hob ignition).

Audio screen

On the radio screen press the more button (right arrow) to access the audio settings. Use the additional slider controls to adjust the levels.



Tone

Use the slider bars to adjust the treble, middle or bass levels.

Loudness

Use the loudness slider to further adjust some audio frequencies to suit requirements.

Balance

Use the balance slider to adjust the levels between the left and right speakers.

Fader

For installations with 4 speakers, use the fader slider to adjust the levels between the front and rear speakers.

SWIFT COMMAND POWER CONTROL SYSTEM

2.16 Bluetooth Pairing & Other Controls

The EC800 control panel can display the software version number of the Control Panel, the PSU and the communicator / tracking unit. Press the settings button to view the setting screen which contains the related information.

The Bluetooth pairing process is covered below. Further help with Bluetooth pairing is available in the form of a help video which can be viewed on the Sargent website in the Support Information section.

General settings screen

Here you can set the date & time, screen brightness and screen on time.



Time, Date & Day

Press the (+) or (-) buttons above or below each item to adjust the value. Note that the system uses the 24 hour clock.

Screen settings

Press on the screen brightness button to adjust the screen backlight level. Press on the screen timeout button to select the time that the screen will stay illuminated for after a press or touch.

Bluetooth Pair

Press the pair button to start pairing with your compatible Bluetooth device. The pair button border will illuminate when pairing is active. You can now pair your device to the system following the devices instructions. Pairing remains active for 1 minute and is then turned off automatically.

Bluetooth Delete

Press the delete button to delete any Bluetooth pairings from the system.

Key Beep

Use the key beep button to turn on / off the beep sound when a button is pressed.

Note: Setting changes are saved when you press the home button to return to the main screen.

2.17 AL-KO ATC Operation

On caravans fitted with AL-KO Trailer Control, the Swift Command App can be used to monitor the status of the ATC from within your tow vehicle. More information on this can be found within the Swift Command App and the associated user guide.

Note: If using the Swift Command app to monitor the ATC whilst driving the phone or device must be placed in a suitable holder and setup before driving. At all times ensure you obey the legal requirements for using mobile devices in vehicles.

2.18 System Warnings

The system incorporates a number of warnings that are active at specific times. These are summarised below, and also covered by relevant sections of this manual.

When a warning is active a warning box will appear on the control panel screen containing a description of the warning along with an audible beeping sound.

Warning	When	Type
Fresh water level low	With pump turned on and fresh water level low (less than 25% full) Only available when an on-board tank is fitted.	Message on screen and 60 second audible beep
Waste water level full	With pump turned on and waste water level full. Only available when an on-board tank is fitted	Message on screen and 60 second audible beep
Leisure battery voltage low	With control panel power on and leisure battery selected (as active battery) and the voltage level falls below 10V	Message on screen and 60 second audible beep
	With control panel power on and leisure battery selected (as active battery) and the voltage level is below 9V	Message on screen and 60 second audible beep. If no action taken after 30 seconds then the system will switch the power off to prevent severe discharge of the battery
	<p>Note: This is an emergency cut off level to protect the battery from severe damage. You should not rely on this cut off level during normal operation, but manage your power consumption to a discharge level of 11.5V or above.</p> <p>This cut off only applies to power drawn from the battery by the leisure equipment that is controlled by the control panel power switch; it will not protect the battery from discharge by permanently connected equipment.</p>	
Leisure battery voltage high	With control panel power on or off and leisure battery is selected (as active battery) and the voltage level rises above 15V	Message on screen and repeated beeps from the control panel. The power is automatically turned off. The beeping will not stop until the fault is cleared.
Vehicle battery warnings	If the vehicle battery is selected instead of the leisure battery, then similar warnings to those described above are applied to the vehicle battery. The vehicle battery low warning level is 10.9V	
Engine running	When the engine is started the system power will be turned off	Message on screen stating 'engine running'.
Step extended	Step extended and engine started	Message on screen and warning buzzer
	Step jammed or obstructed	

SWIFT COMMAND POWER CONTROL SYSTEM

Warning	When	Type
Mains lead (hook-up cable) still connected / plugged in	When the engine is started and the mains cable is still plugged in and the charger is switched on	Message on screen and repeated beeps from the control panel. The beeping will not stop until the hook-up lead is removed.
Heating system	When set to control the heating system, the EC800 control panel will show related heating system warnings, which will include the error number and error description	Message on screen and 60 second audible beep. Additional descriptive information is available when using the Swift Command App.
Refrigerator / Fridge Freezer	When set to control the refrigerator, the EC800 control panel will show related warnings which will include the error number and error description	Message on screen and 60 second audible beep. Additional descriptive information is available when using the Swift Command App.

3 System Technical Information

The following section provides further technical information relating to the electrical system. You can also access the supporting technical manual from www.sargentltd.co.uk

3.1 Residual Current Device & Miniature Circuit Breakers

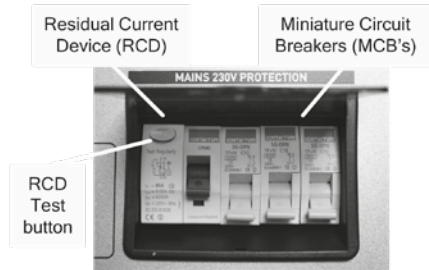

The Residual Current Device (RCD) is basically provided to protect the user from lethal electric shock. The RCD will turn off (trip) if the current flowing in the live conductor does not fully return down the neutral conductor, i.e. some current is passing through a person down to earth or through a faulty appliance.

To ensure the RCD is working correctly, the test button should be operated each time the vehicle is connected to the mains supply (see section 2.3)

The Miniature Circuit Breakers (MCB's) operate in a similar way to traditional fuses and are provided to protect the wiring installation from overload or short circuit. If an overload occurs the MCB will switch off the supply. If this occurs you should investigate the cause of the fault before switching the MCB back on.

The following table shows the rating and circuit allocation for the three MCB's

MCB	Rating	Output Wire Colour	Description
1	10 Amps	White	230V Sockets
2	16 Amps	White (Yellow for heater)	Extra 230V Sockets / Heating System
3	10 Amps	Black (Blue for Whale water heater)	Fridge / Charger / Auxiliary devices / Whale Water Heater

3.2 Generator Usage

Caution should be used before connecting a generator to your caravan.

⚠ WARNING: Never start or stop the generator while electrical loads are connected and switched on. Start the engine, let it stabilise and then connect the electrical load. To stop the engine, disconnect the electrical load and let engine stabilise before switching off

Whilst some generators use electronic inverter technology, others use a more basic principle to generate the 230V supply. Preference should be to choose a generator which produces a consistent sinusoidal wave form with accurate voltage control.

The Reverse Polarity warning light on the PSU may illuminate when using a Generator. This is a normal side effect when using some types of generator. Instead of connecting the neutral conductor to earth, some generators centre tap the earth connection making both neutral and live conductors 110V above earth. This 110V difference causes the neon polarity indicator to illuminate.

In most cases it is safe to use a generator, but please consult the generator handbook for further information.

BATTERY CHARGER

3.3 Battery Charger

The system incorporates an intelligent three-stage battery charger.

During stage 1 the battery voltage is increased gradually while the current is limited to start the charging process and protect the battery. At stage 2 the voltage rises to 14.4V to deliver the bulk charge to the battery. When the battery is charged, the voltage is decreased at stage 3 to 13.6V to deliver a float charge to maintain the battery in the fully charged state. The charger can be left switched on continuously as required.

The battery charger / power converter also provides power to the leisure equipment when the mains supply is connected. This module supplies DC to the leisure equipment up to a maximum of 25 Amps (300 Watts), therefore the available power is distributed between the leisure load and the battery, with the leisure load taking priority as per the following example:

Leisure Load	Available power for battery charging
5A	20A
10A	15A
15A	10A
20A	5A

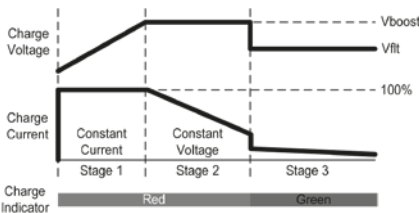

⚠ WARNING: Under heavy loads the Battery Charger case may become hot. ALWAYS ensure the ventilation slots have a clear flow of air. Do not place combustible materials against / adjacent to the charger.

3.4 Leisure Battery**A) Type / Selection**

For optimum performance and safety it is essential that only a proprietary brand LEISURE battery is used and it is suggested to select a battery from the NCC Verified Battery Scheme with a typical capacity of 75 to 120 Ah (Ampere / hours). Depending on the prospective use of the vehicle the correct type should be selected (A, B or C). A normal car battery is NOT suitable. This battery should always be connected when the system is in use.

The PSU is configured to work with standard lead acid leisure batteries, and in most cases is also compatible with the latest range of Absorbed Glass Matt (AGM) batteries. The system is also suitable for Lithium batteries with built-in Battery Management Systems BMS). Before fitting non-standard batteries please check that the charging profile described in 3.3 is suitable for the type of battery by referring to the battery documentation or battery manufacturer.

Some vehicle installations can cater for two leisure batteries connected in parallel. In these cases it is recommended that two identical batteries are used. The battery feed is fitted with an inline fuse between the battery and the electrical harness, and is usually located immediately outside the battery compartment or within 500mm of the battery. The maximum rating of this fuse is 20A per battery.

B) Installation & Removal

Always disconnect the 230V mains supply and turn the PSU green charger switch to the off position (button out) before removing or installing the battery.

When connecting the battery, ensure that the correct polarity is observed (black is negative [-] and red is positive [+]) and that the terminals are securely fastened. Crocodile clips must not be used.

⚠ WARNING: Explosive gases may be present at the battery. Take care to prevent flames and sparks in the vicinity of the battery and do not smoke.

C) Operation / Servicing

Under normal circumstances it should not be necessary to remove the battery other than for routine inspection of the terminals and “topping up” of the battery fluid where applicable. Please see instructions supplied with the battery.

Note: Do not over discharge the battery. One of the most common causes of battery failure is when the battery is discharged below the recommended level of approximately 10V. Discharging a battery below this figure can cause permanent damage to one or more of the cells within the battery.

To prevent over discharge, the power control system incorporates a battery protect circuit that warns the users and then disconnects the batteries when they fall below set values.

If a warning is active a beep will be emitted by the control panel and information will be shown on the screen. To cancel the warning, press the select button. These warnings will not be repeated unless the power switch is turned off and on again. This is to ensure the warning does not become a nuisance.

Battery	Voltage cut off	Action after cut off	Notes
Vehicle	10.9V	Battery selection is changed from Vehicle battery to Leisure battery. If the leisure battery is below 9V then a further warning will occur (see below).	This cut off level is designed to protect the vehicle battery from over discharge. The 10.9V level ensures there is sufficient power in the battery to run the vehicle electronics and start the vehicle. This cut off only applies to power drawn from the battery by the leisure equipment; it will not protect the battery if you leave vehicle circuits switched on, such as the road lights.
Leisure	9V	Power is turned off	This is an emergency cut off level to protect the battery from severe damage. You should not rely on this cut off level during normal operation, but manage your power consumption to a discharge level of about 11.5V. This cut off only applies to power drawn from the battery by the leisure equipment that is controlled by the control panel power switch; it will not protect the battery from discharge by permanently connected equipment.

12V DC FUSES

3.5 12 Volt DC Fuses

⚠ WARNING: When replacing fuses always replace a fuse with the correct value. NEVER replace with a higher value / rating as this could damage the wiring harness. If a replacement fuse 'blows' do not keep replacing the fuse as you could damage the wiring harness. Please investigate the fault and contact your dealer.

The following table shows the fuse allocation for the 13 fuses fitted to the PSU. Please note that fuses are dependant on PSU versions, so not all fuses may be present.

Fuse	Rating	Fuse Colour	Description
1	25 Amps	White	Charger
2	7.5 Amps	Brown	Permanent 12V / Alarm / Fridge Electronics
3	10 Amps	Red	12V Sockets / TV Amplifier / Radio
4	10 Amps	Red	Extractor Fans
5	5 Amps	Tan	Appliances / Hob Ignition / Toilet/ Whale Water Heater
6	10 Amps	Red	Water Pumps
7	7.5 Amps	Brown	Lighting, Main Lights & Dim Channel 1
8	7.5 Amps	Tan	Lighting, Entry Light & Dim Channel 2
9	10 Amps	Red	Alde Heating / Truma Heating / Whale Air Heater
10	10 Amps	Red	Auxiliary / Awning Light
11	20 Amps	Yellow	Not fitted
12	15 Amps	Blue	Not fitted
13	15 Amps	Blue	Not fitted

Note: Fuses (2-13) have a Red LED below them which provides indication that the fuse has blown. The charger fuse has a green LED which indicates that the charger is working.

The following table shows details of the fuse(s) located at the Leisure battery.

Fuse	Rating	Fuse Colour	Description
Battery 1	20 Amps	Yellow	Fuse remotely located near battery
Battery 2	20 Amps	Yellow	Fuse remotely located near battery 2 (where fitted)

The following table shows details of the fuse(s) located at the C44 Road Light fuse box.

Fuse	Rating	Fuse Colour	Description
1	20 Amps	Yellow	Fridge Supply
2	5 Amps	Tan	Left Hand Tail Lights
3	5 Amps	Tan	Right Hand Indicators
4	5 Amps	Tan	Fog Lights
5	-	-	Spare location
6	20 Amps	Yellow	Car Battery Supply
7	5 Amps	Tan	Right Hand Tail Lights
8	5 Amps	Tan	Left Hand Indicators
9	7.5 Amps	Brown	Stop Lights
10	5 Amps	Tan	Reverse Lights

3.6 Common Fault Table

Fault	Possible Cause	Proposed Fix
No 230 volt output from PSU	Connecting lead between the site and Leisure Vehicle not connected	Check and connect lead as per 2.3C
	RCD switched off	Reset RCD as per 2.3D
	RCD not operating correctly	Check supply polarity; if the RCD continues to fail contact your Dealer as there is probably an equipment or wiring fault.
	MCB switched off	Reset MCB by switching OFF (down position) then back ON (up position), if the MCB continues to fail contact your Dealer as there is probably an equipment or wiring fault.
	No or deficient supply from site	Contact site Warden for assistance.
	Other fault	Contact your Dealer
Reverse Polarity light is illuminated on PSU	Mains Supply reversed?	The reverse polarity light is designed to illuminate when the Live and Neutral supply has been reversed / crossed over. If the light illuminates there is a problem with the site supply or the cable connecting the supply to your vehicle. The light is designed to work on UK electrical supplies (where the neutral conductor is connected to earth at the sub station). If you are using your vehicle outside the UK this light may illuminate when no fault exists. In these cases consult the site warden for advice.
	Generator being used	'The Reverse Polarity warning light is on when using my Generator'. This is a normal side effect when using some types of generator. Instead of connecting the neutral conductor to earth, some generators centre tap the earth connection making both neutral and live conductors 110V above earth. This 110V difference causes the neon polarity indicator to illuminate. In most cases it is still safe to use the generator, but please consult the generator handbook for further information.

Fault	Possible Cause	Proposed Fix
Control Panel Problems	Control Panel has no display	<p>Check batteries and fuses, turn PSU isolate switch and charger switch on and ensure mains supply is connected.</p> <p>Check control panel connecting lead at PSU and behind Control Panel.</p> <p>Contact your Dealer.</p>
	12V Power turns off	<p>Battery protect feature has operated to protect the Vehicle battery and or the Leisure battery. See 3.4C</p> <p>Over voltage protection has been activated, the control panel will display a warning. A number of things can cause this but the most common is the solar panel, it is worth checking the regulator is connected correctly and operating within the correct parameters.</p> <p>Engine has been started, all equipment has been disconnected to meet EMC requirements. See 2.4</p>
	Control Panel locked / erratic function	<p>Observe control panel handling instructions.</p> <p>Control panel software may have crashed. Reboot control panel by turning off the PSU isolate switch. Wait 30 seconds then turn the switch back on. Check with your dealer that your system has the latest software installed, as an update may be available.</p>
No 12 volt output from PSU	No 230V supply	Check all above
	Charger not switched on	Turn charger switch on, switch will illuminate
	Battery not connected and / or charged	Install charged battery as per 3.4
	Power button on control panel not switched to on	Turn power on at control panel.
	Battery flat / Battery fuse blown	Recharge battery, check fuses, check charging voltage is present at battery.
	Fuse blown	Check all fuses are intact and the correct value fuse is installed as per fuse table.
	Equipment switched off / unplugged	Check equipment is switched on and connected to the 12V supply
	Other fault	Contact your Dealer

ELECTRICAL FAULTS

Fault	Possible Cause	Proposed Fix
Pump not working	Fuse blown	Replace fuse with correct value as per fuse table
	Pump turned off	Turn pump on by pressing the pump button at the control panel
Lights not working	Fuse/s blown	Replace fuse with correct value as per fuse table.
	Lights turned off	Turn Lights on by pressing the lights button, use dimmer at the control panel.
Comms not working	Bluetooth not paired	Using System Settings menu, select Bluetooth Pair option
	Bluetooth not active on Device	Ensure that the handheld device has Bluetooth switched on and that the device supports the Bluetooth 4 standard (BLE)
	Bluetooth out of range	Ensure the handheld device is within 7M of the middle of the motorhome

3.7 Contact details

Sargent Electrical Services Limited provide a technical help line during office hours. Please contact 01482 678981 if you require technical help.

For out of hour support please refer to the support section of the Sargent web site www.sargentltd.co.uk

4 Remote Access & Control

4.1 Swift Command App

The Swift Command app can be downloaded from the Apple App Store or the Android Play store.

A separate Swift Command User Guide is available which covers the operation of the app.

Before you can use the App with your caravan you will need to create an account and sign up to the free communication service.

This is a simple process and will be explained further by your dealer at the vehicle handover. Additional information is available at www.swiftcommand.co.uk

4.2 Swift Command Web usage & Description

In addition to the mobile App, you can also use the same account and login details to access the Swift Command web site.

Here you can update and amend your details, look at location information and history, review system information and historical data as well as changing some system options and settings.

4.3 Swift Command SIM Coverage & Usage information

The EC600 system contains Mobile SIM with 36 month contract, which commences upon activation at the Dealership when your vehicle is linked to your customer.

Below is a list of the countries covered by the SIM under a fair usage policy, a complete list is available at request.

Austria, Belgium, Bulgaria, Cyprus, Czech Republic, Denmark, Estonia, Finland, France, Germany, Greece, Hungary, Iceland, Ireland, Italy, Latvia, Liechtenstein, Lithuania, Luxembourg, Netherlands, Malta, Norway, Poland, Portugal, Romania, Slovakia, Slovenia, Spain, Sweden, United Kingdom.

For vehicles shipping direct to Australia or New Zealand a special world-wide SIM is fitted at the Swift factory.

Please note that if a UK specification vehicle is shipped to these countries the remote features will not operate.

4.4 Replacement parts

The Control panel contains a small lithium battery to maintain the clock when no other energy supplies are available this will last in excess of 5 years under normal conditions. The battery is a CR2032 3.0V

The EC630 Communication module contains a special backup battery pack which should last in excess of 3 years under normal conditions. The pack part number is 16308 available from Sargent.

4.5 Updates

From time to time there may be updates to the system firmware; these updates will be done at service intervals by your dealership.

5 Technical Data & Approvals

5.1 Equipment – EC601, EC602, EC800, EC635 & PX300

Outline Specification		
INPUT 230V	230 Volts / 0 to 16 Amps	+ / - 10%
OUTPUT 230V	RCD protected, 2 x MCB outputs of 10A & 1 x MCB output of 16A Separate switched channels for heating system and charger	
INPUT 12V	2 x 20A battery inputs via 2 x 4 way connectors	
SOLAR INPUT	1 X Dedicated solar panel input capable of supporting 10A of solar power input (typically 180 to 200W) via a 2 way connector	Check the solar panel rating plate to ensure the maximum current is <= 10A
OUTPUT 12V	25A total output via multiple switched channels protected by 13 fused outputs	
Integrated CHARGER	Input 220-240 Volts AC +/- 10%, Frequency 50 Hz +/- 6%, Current 3A max. DC Output 13.6 to 14.4 Volts nominal, Current 25 Amps max (300 Watts).	
Signal INPUT	4 x Fresh water level, 4 x Waste water level, 1 x Engine running, plus multiple vehicle connections, sensor inputs for temperature & humidity	Fresh water negative sensed Waste water negative sensed
Data IN / OUT	CANBUS Data communication and power to Control Panel via 6 way connector CI-Bus Data communication to CI-Bus enabled devices via RJ11/12 connector	
IP rating	IP31	
Operating temperature	Ambient 0 to 35° Celsius Charger case temperature with full load 65° C Max	Automatic shutdown and restart if overheated / overloaded
Dimensions		
EC601, EC602, EC652 & EC653 PSU	Overall size (HxWxD) 180 x 305 x 135mm Clearances 75mm above, 50mm left & right	Weight 3.8 Kg
EC800 Control Panel	Overall size (HxWxD) 125 x 279 x 25mm Cut-out size (HxW) 108 x 173mm + switch area	Fixing centres 250mm X 74mm Weight 380g
EC635 Comms Module	Overall size (HxWxD) 55 x 116 x 85mm	Weight 550g
EC840 Sensor	Overall size (HxWxD) 20 x 35 x 38mm	Weight 10g

5.2 Approvals

System: BSEN 1648-1, BSEN1648-2
compliant, BS7671: 2008 compliant

Residual Current Device: RCD 40A 30mA
trip to BS EN 61008

Miniature Circuit Breakers: MCB's type C
6000A breaking capacity to BSEN 60898

Electro Magnetic Compatibility (EMC)
directive: 2004/108/EC Certificate
CE20071224-1

Integrated Charger: BS EN 60335-1/2.29,
2006/95EC, IEC61000-3.2/3:1995, 1.

Low Voltage Directive: 2006/95EC TUV-
014900-A1, EN55022, Class B, EN55024/
Level 2

5.3 Declaration of Conformity

Equipment: Leisure Power Control System

**Model name: EC601, EC602, EC800,
EC635 & PX300**

I hereby declare that the equipment named above has been designed to comply with the relevant sections of the above referenced approvals. The unit complies with all essential requirements of the Directives.

Signed	Name	Position	Manufacturer
Date:	I L Sargent	Technical Director	Sargent Electrical Services Ltd Unit 35, Tokenspire Business Park Woodmansey, Beverley East Yorkshire, United Kingdom

Whilst every effort has been made to ensure the accuracy and completeness of this document, no guarantee is given against errors or omissions. This document may be updated / improved over time therefore please check with your dealer / supplier for update information or visit www.sargentltd.co.uk

BATTERY

Battery

⚠ WARNING: Use precaution when removing or replacing the battery, as batteries contain acid liquids which can cause severe injuries and damage when handled incorrectly. Please also take into consideration when manoeuvring a battery, that the weight may be in excess of 20kg.

Your caravan is fitted with a floor mounted battery compartment (Batteries not supplied)

Floor mounted compartments are designed to hold the battery securely and to contain any electrolyte (acid) spillage. Under floor compartments are sealed from the habitation compartment and a breather pipe is fitted to ensure any build up of explosive gases (hydrogen) is vented to the outside. If a breather pipe is fitted it is important to ensure that any replacement batteries are also fitted with a breather pipe. The battery should only be positioned in the appropriate compartment, and be properly secured before travelling.

Note: Batteries fitted in the floor mounted compartment must be kept upright to prevent the electrolyte spilling out.

It is recommended that a good quality leisure battery is always connected when the electrical system is in use. Leisure batteries are a deep cycling rechargeable heavy duty 12v battery designed to provide power for lights and other electrical appliances. It should be remembered that batteries suitable for the electrical demands of a caravan differ in design from those for use with a car, and whilst the system may operate with a car battery it is strongly recommended that only a rechargeable leisure type battery, maintained in good condition, is used. The battery should be kept topped up (charged) at all times.

Batteries should be a proprietary brand leisure battery with a minimum 75Ah capacity. Batteries should be checked dimensionally before purchasing, to ensure fitment within the battery compartment, as brands vary in size.

⚠ WARNING: When connecting the battery, ensure that the correct polarity is observed (black is negative and red/brown is positive) and that the terminals are securely fastened.

Under normal circumstances it should not be necessary to remove the battery other than for routine inspection of terminals and 'topping up'.

⚠ WARNING: Explosive gases may be present at the battery. Take care to prevent flames and sparks in the vicinity.

Your caravan has been fitted with an in-line fuse between the battery terminal and the power supply unit. Do not use a higher rated fuse as this may cause damage to your caravan

⚠ WARNING: Switch off all appliances and lamps before connecting or disconnecting the battery. Smoking is prohibited around the battery compartment.

To preserve the life of your leisure battery and charger please observe the following:

1. Do not leave all 12v lights powered at the same time as this will drain your leisure battery more rapidly.
2. If all 12v lights must be powered together, ensure the battery is 'in-circuit' and that the battery charger is turned on.
3. For optimum performance use the transformer/charger unit with a leisure battery attached.

⚠ WARNING: Your caravan is fitted with Swift Command Tracker (by Sargent) which monitors battery voltage. If you plan to disconnect or remove your leisure battery for maintenance or external charging, then please contact the monitoring station before you remove or disconnect the battery. If a leisure battery is not fitted, please also contact the Tracker monitoring station before removing the mains hook up. The Swift Command Tracker monitoring station can be contacted on 0345 6027302.

Cleaning and maintenance (Floor mounted battery compartment)

- Use protective clothing and glasses when handling a leaking battery, and avoid direct contact to the skin, eyes and respiratory organ.
- Should a battery leakage occur, please act according to the instructions supplied by the manufacturer of the battery. Act with caution as caustic substances are present in the battery.
- Always remove the battery and the power cable before carrying out any maintenance of the product.
- Before removing the clamps switch off all appliances.
- Use a soft cloth or sponge and a non-acid/abrasive detergent when cleaning the Battery Box.
- The cleaning of the Battery Box should only be done after all power sources have been switched off, in order to prevent a hazardous situations.



Factory fitted Solar Energy System (when fitted)

Depending on specification, your tourer may be fitted with a solar panel and regulator. This solar panel and regulator may provide additional 12v power whenever sunlight is available to the panel, and this will be directed to the leisure battery whether the control panel is ON or OFF, and regardless of the position of the SYSTEM SHUTDOWN button. If a factory fitted alarm system is present, that alarm will in turn be able to use the leisure battery as a power supply. Conditions allowing, the system keeps the leisure battery 'topped up' during storage, and will provide a daily boost to the leisure battery when camping without a mains 230V supply.

Battery power

As a guide an 80W panel is capable of supplying up to 4.8 amps, +/- 1.5%.



BATTERY CHARGING / GENERATOR

Regulator

Unlike typical regulators, the factory fitted solar panel regulator has been specially designed to draw no power from the leisure battery when the solar panel is not generating power. This feature is desirable especially in winter months when a normal regulator can gradually discharge the leisure battery.

Regulator operation

The regulator operates automatically, turning on and off as required to charge and maintain the leisure battery. When the solar panel is exposed to a source of sunlight the regulator starts to operate. When the voltage from the panel reaches a usable level, the Panel Output LED will flash indicating that the battery is being charged (see battery charging on next page). If insufficient power is being generated by the solar panel the regulator will turn off. The regulator checks the solar panel output every 30 seconds and turns on and off as required. On overcast days when the solar panel output is minimal the regulator can still deliver a small charge, and in this mode the LED's are not illuminated to conserve power.

Battery charging

If a leisure battery is fitted and requires charging the Charge Status LED will illuminate. Depending on the state of charge of the battery this LED will illuminate red for bulk charge (14.4V output) or green for float charge (13.6V output). It may take a few hours to several days to charge the battery depending on its state of charge. When the battery is fully charged the regulator will turn off to prevent overcharging of the battery. If the mains charger is turned on to charge the leisure battery this can also cause the solar panel regulator to turn off.

Power Supply Unit

The PSU does not need to be switched on (shutdown button in) for the solar panel to charge the battery. During caravan storage the PSU should be shutdown (shutdown button out).

Control Panel

When the solar panel is operating the voltage display on the leisure battery will increase if the loads placed on the battery are sufficiently light.

Maintenance and cleaning

The solar panel will require cleaning periodically in order to maintain the performance of the panel, a caravan, car shampoo or simple soap can be used; no abrasive cleaners should be used.

Generator usage

Caution should be used before connecting a generator to your caravan.

⚠ WARNING: Never start or stop the generator while electrical loads are connected and switched on. Start the engine, let it stabilise, then connect the electrical load. To stop engine, disconnect the electrical load and let engine stabilise before switching off.

Whilst some generators use inverter technology, others use a more basic principle to generate the 230v supply. Preference should be to choose a generator which produces a consistent sinusoidal wave form with accurate voltage control.

The reverse polarity warning light may illuminate when using a generator. This is a normal side effect when using some types of generator. Instead of connecting the neutral and live conductors 110v above earth. This 110v difference causes the neon polarity indicator to illuminate.

In most cases it is safe to continue to use the generator, but please consult the generator handbook for further information.

Habitation relay

Habitation relays are fitted to caravans by manufacturers to comply with the following legislation:

1. The Road Vehicles (Construction and Use) Regulations 1986 Regulation 60 - Radio interference suppression
2. European Community Whole Vehicle Type Approval (ECWVTA) framework directive 2007/46/EC and EU Regulation 661/2009 (General Safety) mandates UNECE Regulation 10 (Vehicles with regard to Electromagnetic compatibility).

A habitation relay must be fitted by manufacturers, safe guarding the consumer. The purpose of the relay is to disable non-homologated appliances/components whilst the vehicle is in transit.

Unintentional electromagnetic energy can be created by non-homologated devices within the habitation compartment, which could cause a malfunction of the towing vehicles electronic systems/components, including safety critical items such as air bags, ABS braking etc.

Exterior 230V Whale Mains Electric Out Socket (when fitted)



This easy access mains out socket includes a UK 3 pin which allows you to hook up electrical appliances with a 13-amp rating such as power tools, lighting, TVs or games consoles. The Easi-Slide lid is designed to be closed completely when in use, weatherproofing the unit against the elements.

Operation:

Open the sliding lid as shown in the image below

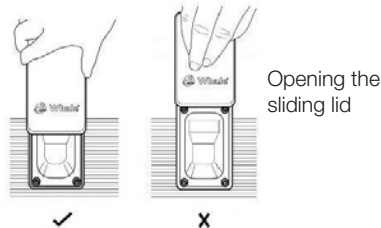

When the caravan is stationary and connected to a 220V/240v supply, raise the front cover of the socket and insert the plug of the equipment to be used. Close and latch the cover into place to provide a weatherproof seal.

EXTERIOR 230V SOCKET

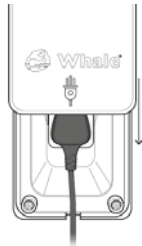
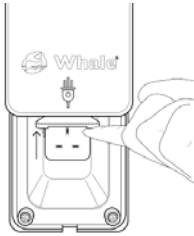

Please remember that the equipment plugged into the socket may not be weatherproof, check with the equipment manufacturer's product information for to confirm.

To disconnect equipment, raise socket cover and remove the plug, then slide the lid down to close it and ensure a weatherproof seal.

Before moving the caravan from a pitch ensure that all accessory points are disconnected and latched in the closed position to prevent the ingress of water or debris causing damage to the point or any of the recreational vehicle's services.

Any item plugged into this socket will be supplied by the same 10A breaker (MCB) as the other items plugged into sockets within the recreational vehicle. Please take into account the total loading placed on the socket circuit and the site supply before switching equipment on. The socket should be used to power a single appliance with an appropriate power consumption rating - the socket is NOT suitable for use as a supply to power an adjacent caravan or motorhome.

⚠ WARNING:

- All mains electric work must be carried out by a competent person as defined by BS7671 PART 2.



- This appliance is not intended for use by persons (including children) with reduced physical, sensory or mental capabilities, or lack of experience and knowledge, unless they have been given supervision or instruction concerning use of the appliance by a person responsible for their safety.
- All socket lids must remain closed when not in use. In adverse weather conditions, for example, snow, frost or heavy rain, please note risk of electrocution exists.

Internal USB Socket Provision

In addition to the 230v sockets and 12v sockets present there is a USB socket at the end of the sink unit. This can be used with a variety of devices such as mobile phones, media players etc, as a power supply for continued running of the device or charging of the internal battery of that device. The socket provides a 5v output in line with the usual USB specification and is powered by the leisure battery and/or charger. The connecting lead between socket and device is not provided, as the format of this lead is device specific.

The fitted USB socket is limited to an output of 2.0 amp – for larger devices such as tablets; use of the adjacent 12v socket with an appropriate adaptor may instead be required. Please check the instructions supplied with your device for further details.

Note: This USB socket does not provide a means of transferring or storing data, and so is not intended for use with memory sticks or other data storage devices.

Whale Water Heater	98
Whale Space Heater	99
Dometic absorption refrigerator	100
Thetford Hob	101
Thetford Grill.....	108
Thetford Oven	108
Thetford C402 cassette toilet	111
Caravans with external BBQ point	111
Caravans with external shower point	112
TV antenna	114
Bedding	115
Doorscreen	115
Exterior door key	115
Exterior door	115
Windows / Roller blinds	116
Rooflights	116
Table / storage	117
Shower use	117
Awning	117
Paint colour reference	118
TV brackets.....	118
Bonded roof	118
Step on hitch cover	118
Caravan motor mover	118

WHALE WATER HEATER

Note: The instructions covering fitted equipment to your caravan were correct at the time of going to print, and where possible, hyperlinks and QR codes have been used, which provide links to online versions of user instructions. Owners handbooks are updated annually and we take great care to try and ensure their accuracy. However, the Swift Group Limited cannot accept responsibility for any changes that may be made in specification or operating instructions to the equipment described in this section after the time of going to press. Every care is taken to ensure that the information provided in this handbook is correct and easy to understand. Separate manufacturers' leaflets on many of the components are also included in the Owner's Pack provided with this caravan and we recommend that you compare the instructions provided via the handbook with the component manufacturers literature, to ensure the information provided is as accurate as possible. If you are in any doubt as to how to operate the equipment in your caravan, please contact the component manufacturer's service department on the telephone number shown on their component leaflet. If you remain in any doubt, please contact your supplying dealer.

Note: In the interest of safety, replacement parts for an appliance shall conform to the appliance manufacturer's specifications and should be fitted by them or their authorised agents.

Whale Water Heater

Your caravan is equipped with a Whale eight litre gas / electric water heater. Quick reference and detailed instructions are available for the water heater, please read these before using the water heater. They are available at:

http://www.whalepumps.com/rv/resources-library.aspx?Application_listItem_ID=11394



If you are unable to view the documents on line, please contact the supplier, your dealer or Swift for an electronic or paper copy.

Note: Never operate the water heater without water in it. Please ensure the water system is primed (water heater drain valve closed, and water system filled with water), and that the vehicle is level, before operating the water heater.

Whale water heater drain valve

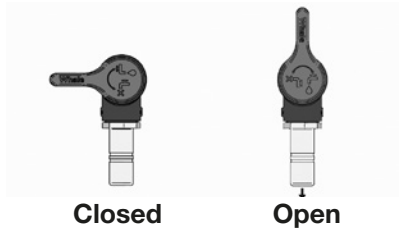

Electrical operation of Whale Water Heater

Once the water system is primed, the 230v isolation button on the Sargent Power Supply unit can be switched ON.

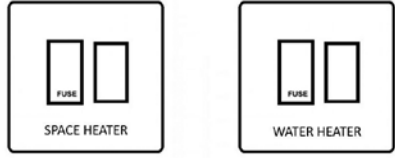
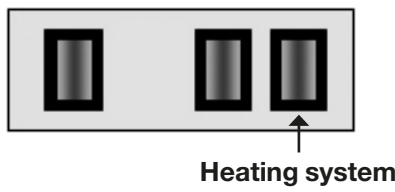

In addition, in the base of the wardrobe are two switched fused spurs which individually isolate the 230v supply to the Whale space heating and water heating appliances. These will be labelled Space Heater and Water Heater, and once the water system is primed, the switch marked WATER HEATER must also be switched ON for electric water heating.

Whale Space Heater

Your caravan is equipped with a Whale underfloor gas / electric space heater. Quick reference and detailed instructions are available for the space heater, please read these before using the heating system. They are available at:

http://www.whalepumps.com/rv/resources-library.aspx?Application listItem_ID=11394



If you are unable to view the documents on line, please contact the supplier, your dealer or Swift for an electronic or paper copy.

Electrical Operation of Whale Space Heater

Before the heating system is used for heating using electrical (230v) energy, the 230v isolation button on the Sargent Power Supply unit must be switched ON.

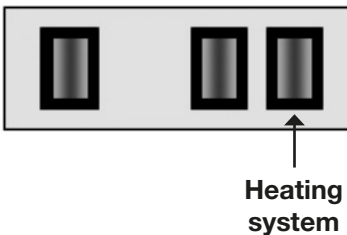

In addition, in the base of the wardrobe are two switched fused spurs which individually isolate the 230v supply to the Whale space heater and water heating appliances. These will be labelled Space Heater and Water Heater, and the switch marked Space Heater must also be switched ON for electric space heating.

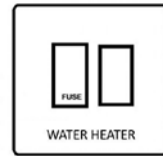
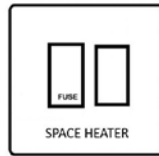

As described in the earlier water heater instructions, the switched fused spur marked WATER HEATER must only be switched on if the water system has been primed, and the water heater itself is full of water.

Troubleshooting

The Space Heater is equipped with an electronic diagnostic system which will detect fault conditions ranging from poor gas or d.c. supply to internal Space Heater malfunctions. In the unlikely event of a failure, the red LED on the Control Panel will light.

In the unlikely event of a failure, the red '!' LED on the Control Panel will light. To identify the lockout press and hold the Space Heater Function Button. The temperature control bars will light to indicate the fault code e.g if 1 bar lights, the fault code is one, if 2 bars light, the fault code is 2 etc. Please refer to the note below.

Note: To clear a lock out.

If 1, 3, 4 or 5 bars are lit indicating a lockout - turn the d.c. power 'off' and then 'on' again at the vehicle's power supply unit. If this does not clear the lockout, or any other lockout is displayed (i.e. 2 or all 12 bars lit) - please press the red Reset Button on the Water Heater once for one second.

If the problem persists contact:

Whale's Support on +44 (0)845 217 2933.

REFRIGERATOR

Warranty

WHALE® is a registered trademark of Munster Simms Engineering Ltd (also trading as Whale®).

The Whale® Space Heater is covered by a 3 year warranty. Please complete the enclosed warranty card and return to Whale.

For warranty details, please see the enclosed warranty statement.

Munster Simms Engineering Ltd.
2 Enterprise Road, Bangor
N. Ireland
BT19 7TA
Tel: +44 (0)28 9127 0531
www.whalepumps.com
Email: info@whalepumps.com

Dometic absorption refrigerator

Before you start using the refrigerator, please read the operating instructions carefully.

These instructions provide you with the necessary guidance for the proper use of your refrigerator. Observe in particular the safety instructions. Observation of the instructions and handling recommendations is important for dealing with the refrigerator safely and for protecting you from injury and the refrigerator from damage. You must understand what you have read before you carry out a task.

Keep these instructions in a safe place close to the refrigerator so they may be referred to at any time.

Your Basecamp caravan is fitted with a Dometic RM8406 absorption refrigerator.

Using this model number, please read the user instructions for the refrigerator, which are available from the following location:

<http://td.dometicgroup.com>



If you are unable to view the documents on line, please contact the supplier, your dealer or Swift for an electronic or paper copy.

⚠ WARNING:

- Appliances and accessible parts become hot during use.
- Avoid touching heating elements.
- Children less than 8 years of age shall be kept away unless continuously supervised.
- This appliance can be used by children aged from 8 years and above, persons with reduced physical, sensory or mental capabilities and/or lack of experience and knowledge only if they have been given supervision or instruction concerning use of the appliance in a safe way and understand the hazards involved.
- Children shall not play with the appliances.
- Cleaning and user maintenance shall not be made by children without supervision.
- Unattended cooking on a hob with fat or oil can be dangerous and may result in fire.
- Never extinguish a fire with water, switch off the appliance and cover flame with lid or fire blanket.
- Danger of Fire: Do not store items on the cooking surface.
- Do not use harsh abrasive cleaners or sharp metal scrapers to clean the oven door glass since they can scratch the surface, which may result in shattering of the glass.
- Never use a steam cleaner to clean appliance.

Introduction

These appliances are designed for cooking foods, any other use is incorrect and dangerous. Failure to install the appliances correctly or improper use, will invalidate any warranty or liability claims.

This appliances must be installed in accordance with the local, national and European regulations in force. Particular attention shall be given to the requirements regarding ventilation. Read the instructions before using the appliances.

Our policy is one of continuous development and improvement. Specifications and illustrations may change subsequent to publication.

Provision of ventilation

The use of a gas cooking appliance results in the production of heat, moisture and products of combustion in the room in which it is installed. Ensure that the kitchen is well ventilated especially when the appliance is in use: keep natural ventilation holes open.

Prolonged intensive use of the appliance may call for additional ventilation, for example opening of a window.

Thetford hob 900 Series

Read the safety instructions and information on use and maintenance of the hob carefully before continuing. This will enable you to use the hob safely and efficiently. Retain this manual for future reference.

For the latest version of the Thetford Manual, please visit www.thetford-europe.com.

Symbols

Key symbols:

⚠ WARNING Risk of injury and/or damage

CAUTION Hot surface. Risk of injury and/or damage

ATTENTION Important information

Safety

⚠ This appliance may be used by children aged 8 years or older and persons with reduced physical, sensory or mental capabilities and/or lack of experience and

HOB

knowledge only if they are supervised or have been given instructions on the safe use of this application and understand the potential hazards.

- ⚠ Keep children younger than 8 years away from the appliance, except under constant supervision.
- ⚠ Do not allow children to play with the appliance
- ⚠ Do not allow children to clean or maintain this equipment unattended.
- ⚠ Use only parts supplied by the manufacturer.
- ⚠ Do not change or adjust anything on the appliance, unless the change is authorised by the manufacturer or its representative
- ⚠ Use the appliance for cooking only and not for anything else, for example room heating. This can lead to carbon monoxide poisoning and overheating.
- ⚠ The manufacturer cannot be held liable for damage resulting from improper use or incorrect setting of controls.
- ⚠ This appliance is not intended to be operated by means of an external timer or separate remote control system.
- ⚠ The use of the gas cooking appliance results in the production of the heat in which it is installed.
- ⚠ Ensure room has sufficient ventilation when then appliance is in use. During prolonged use, additional ventilation may be needed by opening a window or increasing the extraction force of the hood.
- ⚠ Never extinguish a cooking fire with water. Turn the burner off and cover the flame with the lid of a fire blanket.
- ⚠ The burners and pan supports are hot during and after use. Allow all parts to cool before touching them, as this can cause serious injury.
- ⚠ Unattended cooking on a hob with fat or oil can be dangerous and may result in fire. Do not leave the appliance unattended when in use.

- ⚠ The use of inappropriate hob guards can cause accidents.
- ⚠ Do not store items on the cooking surface of the hob.
- ⚠ Do not use steam cleaners or pressure washers to clean the appliance. See Maintenance and cleaning for instructions.
- ⚠ Do not allow oil or fat to build up on the appliance. Clean the appliance after each use.

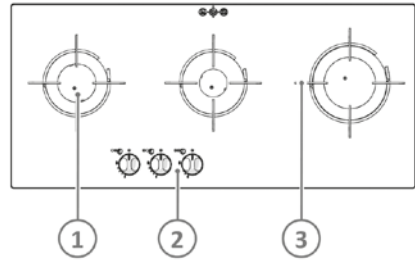

1. Gas burners
2. Pan supports
3. Control panel

Before Use

Before using the appliance:

- Ensure that all the packaging materials have been removed.
- Clean the appliance with warm water and household detergent and dry carefully with a soft cloth.
- Ensure that the gas supply is connected and turned on.
- Ensure that the appliance is connected to the 12V DC battery for the spark ignition.
- Ensure that the pan supports are positioned properly.
- Ignite the gas burner and let them burn to expel odours and vapours first

⚠ ATTENTION: Only use LPG (Liquified Petroleum Gas). The appliance operates on propane or butane. Propane is preferred over butane, because butane provides poor performance at an ambient temperature below 10°C and cannot be used at an ambient temperature below 5°C

Use of the burners



For the exact location of the control knobs, see main components.

Turning on:

- Push and turn the control knob.
- Turn the control knob anti-clockwise to the full rate position
 - For automatic ignition models: The automatic ignition sparks and lights.
 - For non-ignition models: Hold a lit match or gas match to the burners.
- Keep the control knob pressed for about 10-15 seconds and then release it.
- Adjust the height of the flame.

If the burner accidentally extinguishes turn the control knob to the 0 position and wait at least 1 minute before re-igniting the burner.

If the burner has not lit within 15 seconds turn control knob back to the 0 position and release it. Wait at least 1 minute and repeat the steps above to turn on the appliance.

Turning Off

- Turn the control knob clockwise to the 0 position to turn off the burner.

Always make sure the control knob is in the 0 position when you have finished using the gas burner.

Safe cooking

- Do not allow cooking vessels to overlap the edges of the appliance- use the correct sizes of pans and position them centrally over the burners.

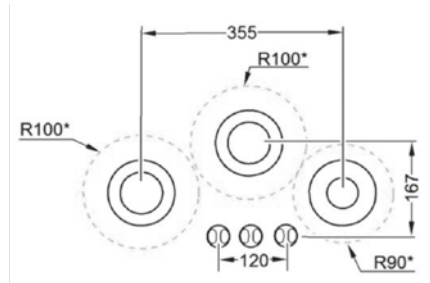

Lay-out based on Topline 167

Burner set-up: 1x1, 0kW: 2x1,5kW

- Ensure that there is at least a 10mm gap between the pans and the edges of the hob.
- Turn the pans so that the handles do not overhang the front of the appliance.
- Ensure that the flame of the gas burner heats the bottom of the pan, not the edges.
- Do not leave the appliance unattended when not in use.
- Do not use the appliance while the vehicle is moving.
- Turn the control knob back to the 0 position after cooking.
- Keep the appliance clean and prevent accumulation of grease and food scraps.

Maintenance and cleaning

Thetford recommends an annual inspection service by an approved service centre. Between annual servicing, clean the appliance regularly after use. Before any cleaning work is started, the appliance should have been left to cool and be disconnected from the gas and electrical supplies.

- Always remove any spills or contamination immediately after use with soap and hot water. Towel dry the surface with a soft cloth.
- Use a non-abrasive multi-purpose cream cleaner and a nylon scourer pad to clean more stubborn dirt or grease.
- For routine cleaning of the glass surface, use a cleaning cream and clean cloth or paper towel. After cleaning, wipe dry with a dry paper towel.

⚠ WARNING: Do not use abrasive cleaners, metal scouring pads or hard brushes. They could damage the appliance.

⚠ WARNING: If you clean the burner rings, ensure that the holes are not clogged.

Note: The control knobs can be removed for cleaning. The knobs are easy to replace.

Gas leaks

As soon as you smell gas:

- Ensure that all burners are turned off.
- Extinguish all naked lights and do not smoke.
- Shut off the gas supply at the gas bottle immediately.
- Do not use electrical switches.
- Open all doors and windows.

⚠ WARNING: LPG is heavier than air. Escaping gas accumulates at lower levels. By following the strong, unpleasant smell of gas, you can determine where the leak is located. To investigate where it is exactly, use a special leak detection spray. Never use an open flame to find the leak!

Trouble shooting

Problem	Problem cause	Solution
Burners do not burn or burn unevenly	Gas bottle is empty Gas tap is closed Burner caps are not correctly positioned Burners are wet or clogged	Fill bottle Open tap Allow caps to cool, then reposition them Dry or clean burners
Automatic ignition does not spark	12V DC battery is discharged Connections are loose Ignition points is wet or dirty	Charge battery Secure connections Dry or clean ignition point
Control knobs do not function	Knobs are mounted incorrectly	Install knobs correctly

If you cannot solve a problem, contact the authorised local Services Centre or Thetford Customer Service in your country.

Servicing

All servicing must be carried out by an approved competent person. Before any service work is started, the appliance should have been left to cool and be disconnected from both gas and electrical supplies. After each service the appliance must be checked for gas soundness and electrical safety.

For service, please contact your authorised local Service Centre giving details of the model and serial number on the data badge plus date of purchase.







Model Name & Series Number		THETFORD	
g30 g31	CAT 1,*(28-30/37) BUTANE 28-30mbar PROPANE 37mbar	CAT 1,B/P(30) BUTANE 30mbar PROPANE 37mbar	Spark Ignition
Qn	Power kW (g/hr)	Model Number	Voltage ~ 50 Hz
CE	Pin Number	Serial Number	Power kW
Country Codes 1	Country Codes 2	QC Pass	Order No







Putting in storage







- Close the gas valve at the gas bottle.
- Disconnect the battery.
- Ensure that the control knobs are in the 0 position.
- Wipe the appliance clean and dry.

HOB TECHNICAL SPECIFICATION

Technical Specifications

	SHB969 series			SHB922 series		
	Gas input		Injector	Gas input		Injector
						
	kW	g/hr	mm	kW	g/hr	mm
Gas burners	1 x 2.5 2 x 1.5	1 x 179 2 x 107	0.77 0.61	2 x 1.5	2 x 107	0.61
Total	5.5	393		3.0	214	

	SHB931 series			SHB923 series		
	Gas input		Injector	Gas input		Injector
						
	kW	g/hr	mm	kW	g/hr	mm
Gas burners	1 x 2.5 1 x 1.5 1 x 1.0	1 x 179 1 x 107 1 x 77	0.77 0.61 0.52	2 x 1.5	2 x 107	0.61
Total	5.0	363		3.0	214	

	SHB910 series - option 1			SHB910 series - option 2		
	Gas input		Injector	Gas input		Injector
						
	kW	g/hr	mm	kW	g/hr	mm
Gas burners	1.5	107	0.61	2.5	179	0.77
Total	1.5	107		2.5	179	

This application is suitable for use with LPG (liquefied Petroleum Gas) and should not be used with any other gas.

⚠ WARNING: This application must be earthed

Disposal

Your product has been designed and manufactured with high quality materials and components, which can be recycled and reused. When your product has reached the end of life, dispose of the product according to the local rules. Do not dispose of the product with the normal household waste. The correct disposal of your old product will help prevent potential negative consequences to the environment and human health.

Questions

If you have questions about your product, parts, accessories or authorised services:

- Visit www.thetford-europe.com
- If you cannot solve a problem, contact the authorised local Service Centre or Thetford Customer Service in your country.

Warranty

Thetford BV offers the end users of its products a three-year-warranty. In case of malfunction within the warranty period, Thetford will replace or repair the product. In this situation, the costs of replacement, labour costs for the replacement of defective components and/or the costs of the parts themselves will be paid for by Thetford.

Purchased spare parts carry a one-year-warranty. Any fitting and/or labour costs are not covered by warranty.

1. To submit a claim under this warranty, the user must take the product to an authorised Thetford Service Partner. The claim will be assessed there.
2. Components replaced during repair under warranty become the property of Thetford.
3. This warranty does not prejudice current consumer protection laws.
4. This warranty is not valid in the case of products that are used for commercial purposes.
5. Warranty claims falling into one of the following categories will not be honoured:
 - The product has been improperly used or the instructions in the manual have not been followed
 - The product has not been installed in accordance with the instructions
 - Modifications have been made to the product
 - The product has been repaired but not by an authorised Thetford Service Partner
 - The serial number or product code has been tampered with or removed
 - The product has been damaged by misuse

GRILL

Thetford MK3 Mini Grill (when fitted)

⚠ WARNING:

- The grill area can get hot when the oven is in use, even if the grill is switched off.
- Care should be taken when removing pans from the grill, i.e. use of oven gloves, and by making use of the removal grill pan handle.

Using the Grill

1. Ensure gas cylinder/supply is connected and turned on.
2. Open door, push in the control knob and turn anti clockwise to the large flame symbol (🔥) – see Grill Control position below
3. Continue depressing the knob whilst holding a lighted match to the burner. For models fitted with spark ignition the procedure is similar except that burner is ignited by depressing the ignition button located on the fascia.
4. After the burner is lit continue depressing the knob for approximately 10 - 15 seconds before releasing the knob.
5. If burner has not lit within 15 seconds, release knob and wait at least 1 minute before repeating operations (2) to (4).
6. To turn off, rotate the control knob until the line on the knob is aligned with dot on the control panel.
7. Always make sure the control knob is in the off position when you have finished grilling.

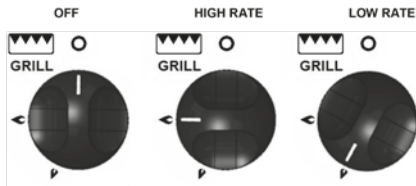

Grill Control Panel

Note:

- The grill pan supplied is multi functional, for use in grill or oven.
- The handle design allows removal or insertion whilst the pan is in use.
- Always remove the handle when the pan is in use.
- The grill MUST only be used with the door open.
- The heat deflector below the fascia should be pulled out prior to lighting the grill. Never adjust the heat deflector position without using hand protection – ie oven gloves.

On first use of the grill, it should be heated for about 20 minutes to eliminate any residual factory lubricants that might impart unpleasant smells to the food being cooked. A non-toxic smoke may occur when using for the first time, open any windows and turn on mechanical ventilators to help remove the smoke.

Although the grill heats up quickly, it is recommended that a few minutes preheat be allowed.

It is normal for the flames on this burner to develop yellow tips as it heats up.

Depending on the food to be cooked the correct grilling height can be achieved by inverting the pan trivet into either the high or low position.

Thetford MK3 Oven (When fitted)

1. Ensure gas cylinder/supply is connected and turned on.
2. Open door, push in the control knob & turn to full rate (Gas Mark 9, 240°C) see Fig 4
3. Continue depressing the knob whilst holding a lighted match or taper to the burner. For models fitted with spark ignition the procedure is similar except that burner is ignited by depressing the ignition button located on the fascia.
4. After the burner is lit continue depressing the knob for approximately 10 - 15 seconds.

5. Release the knob and turn to required heat setting.
6. If the burner has not lit within 15 seconds, release knob and wait at least 1 minute before repeating operations (2) to (5).
7. Place the oven shelf in the required position and close the door.
8. Although the oven heats up quickly a 10 minute preheat is recommended. The oven should reach full temperature in about 15-20mins.
9. To turn off, rotate the control knob until the line on the knob is aligned with dot on the control panel.
10. Always make sure the control knob is in the off position when you have finished.



Oven Control Panel

The oven shelf has been designed to allow good circulation at the rear of the oven. A raised bar at the rear of the shelf prevents trays or dishes making contact with the back of the oven. To remove a shelf, pull forward until it stops, raise at front and remove. Installation of a shelf is the reverse of this procedure.

Note: Before using your oven for the first time we recommend the following procedure:-

Clean all surfaces with hot soapy water. Light the oven and set control knob to Gas Mark 5 (200°C). Heat the oven for about 30 minutes to eliminate any residual factory lubricants that might impart unpleasant smells to cooked food.

A non-toxic smoke may occur during this procedure, open any windows and turn on mechanical ventilators to help remove the smoke.

⚠ WARNING:

- Ignition must be carried out with the door open.
- The pans and trays supplied with this appliance are the maximum sizes recommended for use. Larger pans and trays may restrict good circulation of heat, increasing cooking times.
- Always ensure food is properly cooked prior to serving.



Oven Temperature Control

The temperature in the oven is controlled by a thermostatic gas tap and is variable over the range 130°C to 240°C. Approximate temperatures for the settings on the control knob are shown in the cooking chart. The temperatures indicated refer to the centre of the oven and at any particular setting the oven will be hotter at the top and cooler towards the base.

The variation between top and centre, and centre to bottom is approximately equivalent to one gas mark. Good use can be made of the temperature variation in several dishes requiring different temperatures may be cooked at the same time. In this way maximum benefit can be obtained from the gas used to heat the oven.

Care should be taken not to overload the oven, allow adequate spacing to ensure free circulation of heat. When roasting with aluminium foil ensure the foil does not impair circulation of heat or block any oven flue outlet.

OVEN

Oven Temperature Zones					
Gas Mark					Dish
¼ - ½	90°C	110°C	130°C	Very Cool	Meringues
1	110°C	130°C	150°C	Cool	Stewed fruit
2	120°C	140°C	160°C	Cool	Rich fruit cake, rice pudding
3	130°C	150°C	170°C	Warm	Baked custard, shortbread fingers
4	140°C	160°C	185°C	Moderate	Victoria sponge
5	155°C	180°C	200°C	Fairly Hot	Whisked sponges, ginger nuts
6	170°C	190°C	215°C	Hot	Short crust pastry
7	185°C	210°C	230°C	Hot	Bread, scones, flaky pastry
8	200°C	220°C	245°C	Very Hot	Puff pastry
9	215°C	240°C	260°C	Very Hot	Quick browning

⚠ WARNING:

- When cooking, young children should be kept away.
- The pans and trays supplied with this appliance are the maximum sizes recommended for use. Larger pans and trays may restrict good circulation of heat, increasing cooking times.
- Always ensure food is properly cooked prior to serving.

Do's and Don'ts

- DO** Read the user instructions carefully before first use of appliance.
- DO** Allow the oven to heat before using for the first time, in order to expel any smells before the introduction of food.
- DO** Clean the appliance regularly.
- DO** Remove spills as soon as they occur.
- DO** Always use oven gloves when removing food shelves and trays from oven.
- DO** Check that controls are in the off position when finished.
- DO NOT** Allow children near the cooker when in use. Turn pan handles away from the front so that they cannot be caught accidentally.
- DO NOT** Allow fats or oils to build up in the oven trays or base.
- DO NOT** Use abrasive cleaners or powders that will scratch the surfaces of the appliance.
- DO NOT** Under any circumstances use the appliance as a space heater.
- DO NOT** Put heavy objects onto open grill or oven doors.

Thetford Toilet



Your Basecamp caravan is fitted with a Thetford C402 toilet. Using this model number, please read the user instructions for the toilet, which are available from the following location:

https://www.dropbox.com/s/ug83cn7ezz9mq6q/C400-User-manual_32220_1212-V01.pdf?dl=0



If you are unable to view the documents on line, please contact the supplier, your dealer or Swift for an electronic or paper copy.

Caravans with Whale External BBQ Outlet Socket (when fitted)

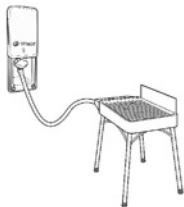

This Whale External BBQ Outlet Socket is designed to supply an exterior BBQ using your LPG (Propane or Butane) recreational vehicle on board gas supply.

- This tap is designed solely for gas supply from the vehicle to an exterior BBQ.
- The valve is designed in accordance with BS EN 1949-2011 and cannot be operated unless the hose fitting is in place.
- The gas tap has an integrated non-return valve therefore gas cannot be supplied to the vehicle.



Pn = 30mbar
No LPG Insert

Operation:

Opening the sliding lid

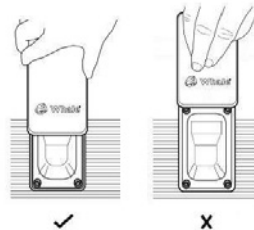

With appropriate connector fitted to hose on BBQ by a Qualified Gas Engineer, insert connector into outlet as shown below:

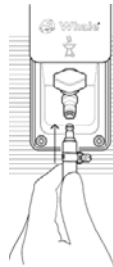

Rotate valve handle to the ON position as shown in the image below to start the gas supply to your exterior BBQ. Please note valve handle will not open and gas supply won't flow when hose is not connected. This is an additional safety feature of the Whale External BBQ Outlet Socket.



EXTERNAL BBQ POINT /
EXTERNAL SHOWER POINT

To disconnect, first turn the valve handle back to the OFF position as shown above, then slide back the collar to release the connector and remove as shown in the image below. Ensure socket lid is closed when not in use.

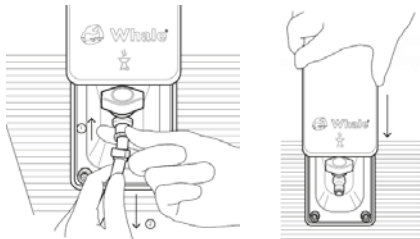

Whale Water Out Socket with Whale Compact Shower (when fitted)

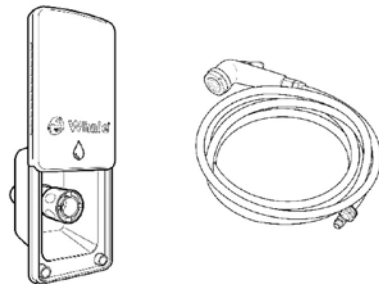

The water out socket, if fitted, will be supplied with a separate shower head and hose.

Operation:

Assemble hose and fittings as shown in the image below.

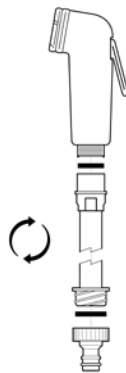

Open the sliding lid as shown in the image below.

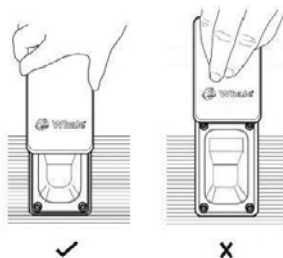

⚠ WARNING:

- Care must be taken when using the external BBQ outlet socket. Never barbeque next to an awning or tent.
- Only for use as an outlet point for gas, never connect a gas bottle directly to the outlet.
- Whale BBQ sockets including the rubber pipe fitting must only be modified or serviced by a Qualified Gas Engineer.
- In the unlikely event of leaks in the gas system, or if there is a smell of gas:
 - Extinguish all naked flames
 - Switch off all appliances and do not operate any electrical switches
 - Turn off all gas appliances
 - Open windows and doors for ventilation
 - Do not smoke
 - Shut off gas connection
 - Immediately ensure that the system is thoroughly checked by a Qualified Gas Engineer.
- This appliance is not intended for use by persons (including children) with reduced physical, sensory or mental capabilities, or lack of experience and knowledge, unless they have been given supervision or instruction concerning use of the appliance by a person responsible for their safety.
- Regularly inspect gas tap to ensure inside nozzle is free from debris, and gas connection to the rear has not been damaged.

EXTERNAL SHOWER POINT

Push back collar and remove end stop as shown in the image below.

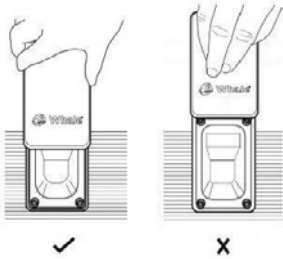

Push back collar and remove end stop as shown in the image below.



Align the shower hose connector with the socket and push into position as shown in the images below.

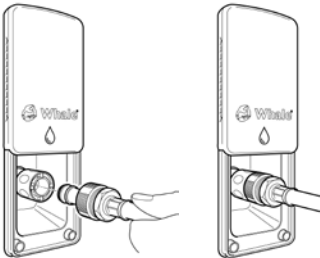

To remove shower, push back the collar on the shower outlet fitting, then pull the shower hose connection away from the socket.



⚠ WARNING: This socket is for water out use only. To avoid risk of damage to the water system, do not use to supply water to the vehicle.

⚠ WARNING: During periods of cold weather, ensure vehicle is fully drained of water to avoid damage to socket and fittings.

TV ANTENNA

Status Directional TV Antenna

Your caravan is fitted with a Status 570 TV aerial. Please read the user instructions for the TV aerial, which are available from the following location:

<http://www.visionplus.co.uk/assets/pdfs/2016/570%20RETAIL%20Instructions%20A3%20Lilac%2018-08-15.pdf>



If you are unable to view the documents on line, please contact the supplier, your dealer or Swift for an electronic or paper copy.

BEDDING / DOORSCREEN

Bedding

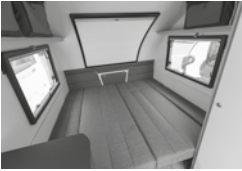

Double bed assembly:

1. Grab front on slatted bed and pull into centre of van. Repeat for other side.
2. Arrange seat cushions as appropriate.

Doorscreen (when fitted)

The door flyscreen is tracked top and bottom and operation must be by the centre of the handle to aide a smooth operation.

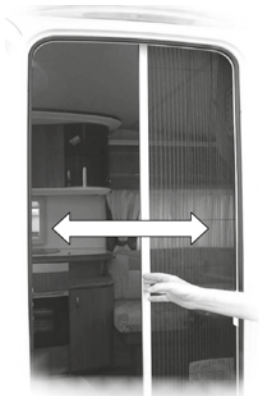

⚠ WARNING: When opening or releasing the doorscreen, care must be taken to avoid trapping fingers.

Exterior Door Key

⚠ WARNING: Care should be taken not to leave the exterior door key in the door when unlocking the door. The key may result in damage in the vehicle side if the door is released with the key still in the lock.

⚠ WARNING: The door retainer is designed to hold the door in normal conditions. In gusty or windy conditions we recommend the door is closed to prevent it releasing and slamming shut.

The door flynet operates independently of the door by sliding across the door threshold.

Exterior door

Operation:

The door is locked from the inside by rotating the outer handle vertically. To operate the deadlock facility rotate the inner handle vertically so it is in-line with the two raised pips on the dial.

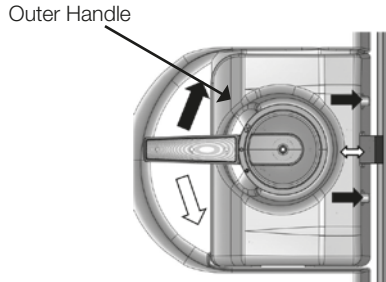

WINDOWS / ROOFLIGHT

Windows

To open all window types push the central button with your thumbs and turn the internal handles through 90 degrees and push open the window.

On models fitted with ratchet stays:

the window locks in the open position to pre-set positions located within the stay. To operate, push open the window until you hear an audible click and then slowly release the pane and the window will be locked in the first open position. Push open again to find the next locking position. To close, fully open the window which will disengage the locks and allow the window to close slowly and lock off the handles by turning back through 90 degrees.

Windows / Roller Blind Advice

In case of prolonged exposure to the sun roller blinds should not be completely closed as this could cause excessive heat concentration at the top of the window, due to characteristics of the glazing material the windows could be adversely affected.

Roller blinds that shade from the bottom upwards it is necessary to leave a gap of a few centimetres open at the top, this way the heat between window and blind can escape. A fly screen does not cause an obstruction.

Roller blinds that shade from the top downwards must be kept completely open, or be opened regularly to allow the heat to escape.

Keeping the windows in ventilation position allows heat to escape.

Never fully close a roller blind system when storing the vehicle or when not in use for longer periods!

Roof lights

When opening the roof lights, care must be taken to release the locking mechanism as the unit is raised.

Roof lights must be fully closed when towing.

Roof lights provide varying levels of fixed ventilation.

Therefore for optimal window life it is recommended:-

- Blinds starting at the bottom of the window a gap should be provided for ventilation at the top with the window in its ventilation position.
- For vehicles containing blinds from the top downwards or with other types of reflective blinds / curtains, please make sure that these blinds are also ventilated or not fully closed.

Ensure that all windows and roof vents are closed when the vehicle travels on the road.

MPK Rooflight (when fitted)

⚠ WARNING:
Never stand on the dome of the rooflight!

**Instruction for use**

The rooflight can be opened fully, or in four different directions, so that the dome can be angled against driving weather conditions. The handle profiles of both roller blinds (flynet and roller blind) click into space at the edge of the frame and can be opened by pulling the handle (arrow on the handle profile).

With both handle profiles clipped together they can be moved to any position. To separate, fully open the flynet and squeeze together the catches on the central lock and allow flynet to recoil.

Free-air-flow

⚠ WARNING: When closed there is a free airflow throughout the rooflight, which must be kept free at all times.

Before driving

IMPORTANT: All rooflights must be locked down before travelling and both roller blinds locked in the fully open position against the frame.

Care instructions:

The rooflight should only be washed by hand, using a sponge with plenty of clean water to avoid scratching. Caustic detergents and solvents may attack the plastic and make it brittle or disintegrate.

For easier cleaning of the dome it can be removed from the frame by releasing the four screws holding the handle arms. Do this from the inside of the van.

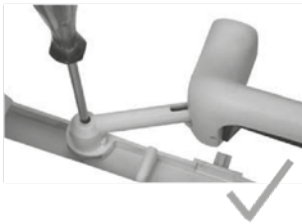

Lift the dome clear of the roof and rotate so that it can be lowered into the van across the diagonal of the aperture.

Make sure that only the original screws are used when replacing the dome and that they enter the thread in the plastic correctly. Do not over-tighten.

Never remove the screws holding the dome and the handles together. These are secured by a torque screwdriver and should only be handled by an approved dealer.

Table storage

To avoid damage care must be taken when removing tables from their stored position.

Tables stored in the table storage compartment must be securely clipped into place whilst in transit.

⚠ WARNING: When erecting the free standing table, be careful to avoid trapping fingers.

Shower use

- Care should be taken as water may become hot temporarily when switched on until it mixes and regulates.
- Small children should be supervised at all times when using the shower.
- We recommend unfastening the shower head before travelling and storing safely to prevent it becoming detached whilst towing.

Awning

A Vango Air Awning has been specifically designed to fit the rear of your caravan. This option is available through the dealer network and should you wish to purchase then please contact your supplying dealer.



Assembly

Before pitching your awning study the photograph on the awning bag, this illustrates what the awning should look like when assembled. Check that all the components are correct and undamaged. Review the assembly instructions and familiarise yourself with the procedures before pitching your awning for the first time.

Care points

Whilst all the seams on your awning are taped to prevent these seams leaking, due to the way the awning is affixed to the caravan in some circumstances you may experience some ingress of water in these attachment areas. Awnings should be taken down in strong winds to protect body panels from cosmetic damage.

Fire precautions

Keep any naked flames away from the awning fabric. Awnings should be kept ventilated when discharging products of combustion exhaust in to them. Do not place hot appliances near the walls, roof or curtains. Always observe the safety instructions for these appliances. Never allow children to play near hot appliances. Keep passage ways clear. Make sure you know the fire precaution arrangements on the site. Make sure ventilation openings are open all the time to avoid suffocation.

Ventilation

All awnings are prone to condensation when air on the inside is warmer than outside. Increase ventilation by leaving doors open when possible and opening vents.

Cleaning and drying

Whenever possible pack the awning when it is dry. If wet, dry thoroughly at first opportunity if the awning is to be stored. Storing the awning when wet will cause mould to grow, which will degrade the fabric.

Warranty

The awning is supplied with a standard 2 year warranty which can be extended by a further year if the awning is then registered with Vango.

Contact numbers

Vango can be contacted by Telephone on 0844 770 7058 or alternatively by logging on to the Vango web site at vango.co.uk

Colour reference

If the caravan requires touch-up paint or a respray, the correct colour code for all white components is Fiat White 249.

Please be aware that colours can fade over time, and therefore, if the vehicle is more than a few years old, it is suggested a colour match be obtained. If these are small areas that do not require a full respray of the entire panel you can use an over the counter polishing compound to return the original finish. We would always recommend that an inconspicuous area of the caravan is tested beforehand.

TV Brackets (when fitted)

In some models a bulkhead mounted bracket is supplied to mount a TV on. Whilst the bracket has a secure travel lock, it is good practise to un-clip the TV from the bracket and store securely for travelling.

Bonded Roof

The roof of your caravan is made from a bonded construction. Care should be taken when cleaning the roof not to walk directly on the roof. If access to the roof is required the weight of a person should be spread across a larger area using a spreader board and extreme care should be taken when working at heights.

Step on hitch cover

Where a step on hitch cover is fitted, customers are reminded only to stand on the designated areas, identified with black anti-slip matting. Stepping elsewhere on the hitch cover may result in damage to the hitch cover.

Models without a step on hitch cover are not suitable for standing on and failure to follow these simple instructions may result in premature failure or cracking which will not be covered by any guarantees (including extended warranties).

Caravan motor movers

The design and fitment of a caravan motor mover shall be in accordance with the NCC Code of Practice 305 and you should ensure you receive a signed installation certificate of compliance from the installer.

Failure to do so may invalidate your warranty

Fenix® work surfaces	120
Vehicle modification and non-standard parts	122
Caravan movers	122
Caravan exterior	124
Condensation	123
Caravan interior maintenance	124
Winterisation/storage	126
AL-KO chassis	129
AL-KO ATC control system.....	130
Axle types	135
Stabilisers and coupling devices	139
Overrun device	141
Chassis trouble shooting	143
Chassis accessories	145
Basecamp technical specification	146
Bulb replacement instructions	147
Basecamp wiring diagrams	148

FENIX WORK SURFACES

FENIX Work surfaces

Ordinary maintenance

FENIX NTM surface should be cleaned regularly but does not require any special maintenance, just a damp cloth with warm water or mild detergents. Almost all normal household cleaning products or disinfectants are perfectly well tolerated. It is suggested to use a melamine foam sponge - also known as magic sponge - for the normal cleaning and maintenance of the surface.

Extraordinary maintenance

In case of dirt which cannot be cleaned with normal household detergents, due to the irregular topography and closed surface of FENIX NTM, the use of non-aggressive aromatic solvents (acetone) is suggested. In case of micro scratches, please refer to the specific surface thermal healing instructions.

Recommendations for cleaning the surface of FENIX NTM

The table below shows the cleaning products and methods best suited to different types of dirt.

Type of dirt	Recommended cleaning products and method
Syrup, fruit juice, jam, spirits, milk, tea, coffee, wine, soap and ink	Water with a sponge
Animal and vegetable fats, sauces, dry blood, dry wine and spirits, eggs	Cold water with soap or household detergent with a sponge
Smoke, gelatine, vegetable and vinyl based glues, organic waste, gum arabic	Hot water with soap or household detergent with a sponge
Hair spray, vegetable oil, biro and felt tip, pens, wax foundations and greasy make-up, residual solvent marks	MEK, alcohol, acetone with a cotton cloth
Nail polish, spray lacquer, linseed oil	Acetone with a cotton cloth
Synthetic oil paints	Trilene nitre based solvent with a cotton cloth
Neoprene glues	Trichloroethane with a cotton cloth
Traces of silicone	Wooden or plastic scraper, taking care not to scratch the surface
Lime deposits	Detergents containing low percentages of citric or acetic acid (10% max.)

General precautions

For best results in cleaning FENIX NTM, it is important to remember certain precautions:

- although very durable, the surface of FENIX NTM must still never be treated with products containing abrasive substances, abrasive sponges or unsuitable products, such as sandpaper or steel wool;
- products with a high acid or very alkaline content should be avoided because they can stain the surface;
- when using solvents, the cloth used must be perfectly clean so as not to leave marks on the FENIX NTM surface. Any streaks can still be removed by rinsing with hot water and drying;
- avoid furniture polishes and wax based cleaners in general, because they tend to form a sticky layer on the dense FENIX NTM surface, to which the dirt adheres.

Maintenance Instructions

Melamine foam Sponge

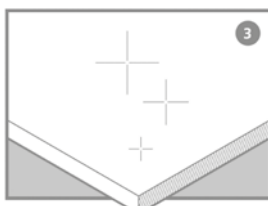
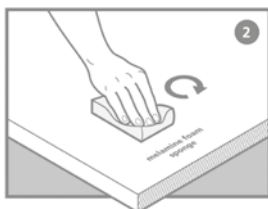
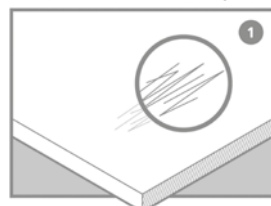

Maintenance Instructions

Iron

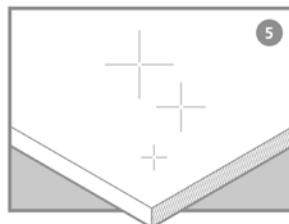
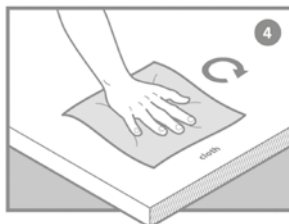
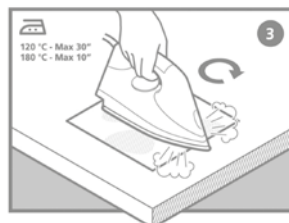
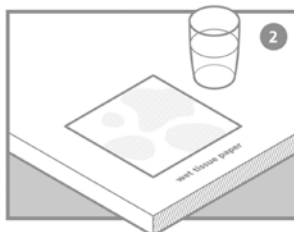
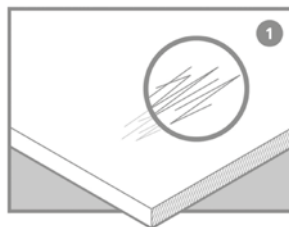

MODIFICATIONS / CARAVAN EXTERIOR

Vehicle modifications & non-standard parts

As the owner of a Swift Group Product, you are able to make any modifications you wish, either by yourself or through a dealer, without affecting the Swift 3/6/10 Year Warranty.

However, please be aware that any issues, resulting directly or indirectly, from a modification or fitment of a non-standard part, will not be covered by The Swift Group Warranty.

WD40 is not recommended for external or internal use.

WD40 attacks paintwork and sealants.

If a lubricant is required for Interior hinges, Sliding door tracks, Bottle box hinges, Exterior door hinges, Plastic tracking etc. We recommend "Ambersil 40+" this is readily available from most DIY/ Automotive spare part retailers

Before carrying out any DIY work within the warranty period (3/6/10) years please check with your Swift Group dealer.

REPLACEMENT PARTS: The Swift Group recommend that only OEM approved replacement parts are used.

Caravan movers

If thinking of installing a caravan mover as an after fit it is advisable to consult your dealer, as this may not be possible with shock absorbers (if fitted) or impede the AL-KO jacking point.

Caravan exterior

Plastic Panels (GRP)

These are used for front and rear panels, side walls and roof.

Cleaning

1. Wash the caravan regularly with mild detergent. Rinse with cold water and leather off.
2. For better protection a similar coloured good quality car wax may be applied.

For sealed areas a mild soap is the best way to clean without affecting the sealant.

Acid or alkaline based cleaners or solvents should not be used.

⚠ WARNING: Under no circumstances use any abrasive cleaning agents or solvents on the exterior panels.

Care should be taken as the silicon in some polishes can attack the rubber used on the exterior for seals and gaskets.

⚠ WARNING: Do not wash your caravan with a high pressure washer as these can permanently damage the seals of your caravan.

Acrylic Windows

Wash windows carefully, as you would with the paintwork of your car, do not scrub windows prior to removing surface dirt and film with a hose pipe - trapped dirt could cause scratching.

Wash with a solution of warm soapy water, windows can then be dried off with a leather.

Small scratches can be removed, consult your dealer.

Catches and stays do not require any special attention or lubrication.

Acrylic (Plastic) Window Condensation

Unlike domestic double glazed windows, your caravan windows are not vacuum sealed instead the double panes of acrylic plastic with are fitted with a breathable plug on the inner pane.

It is possible, in weather where extremes in temperatures occur between night and day, that customer will notice condensation between the panes. The same phenomenon may also occur when washing your vehicle on a hot day.

The condensation should clear itself when the ambient conditions return to normal and the air between the panes dries. However, if this is taking a longer time than required, the breathable plug (normally located in the top corner of the window) can be removed, with

a pin or sharp object, and replaced when the panes are dry. Care should be taken when doing this.

Acrylic (Plastic) Window Cleaning

The material used to produce most caravan and Motorhome windows is acrylic plastic. While the acrylic used is very durable, it is able to be scratched with relative ease and therefore, care must be taken when cleaning your vehicle with warm soapy water and not to use aggressive clearing products. Equally, care should be taken when using a drying cloth that it is clean and free from grit.

Condensation

What is condensation

Condensation is the process of change of water from its gaseous form (water vapour) into liquid water when it comes into contact with a surface that is cold. Condensation generally occurs when warm air cools quickly and loses its capacity to hold water vapour, and as a result water vapour condenses to form droplets.

Why condensation occurs

Condensation occurs when warm moist air meets a cold surface. The level of condensation will depend upon humidity levels, how moist the air is and how cold the surfaces are they come into contact with.

If the temperature falls below the dew point temperature, it is quite normal for condensation to occur on any material within the caravan that is cold, for example the external walls, plastic windows etc.

When condensation occurs

Condensation occurs usually in winter months, because ambient temperatures are colder (leading to cold surfaces) and windows and roof vents are opened less so the moist air cannot escape.

Where condensation occurs

Condensation will occur where warm moist air is put into the atmosphere in areas such as in bathrooms (during showering) and in kitchen areas (during cooking).

In the enclosed space of a caravan, the moist air from the kitchen or bathroom areas will inevitably transfer to the rest of the vehicle, which in turn condenses on cold surfaces leading to visible water droplets. This issue is compounded by warm moist air being generated from normal breathing.

Condensation will also form in cold areas where air movement and ventilation is restricted (e.g. cupboards, wardrobes, under beds, etc.)

What is important

It is important to provide ventilation and air flow, so that warm moist air can escape, or be externally cooled, and to use the heating reasonably by not making the caravan too warm such that people perspire, as this will only serve to generate more moist air and therefore more condensation.

However, in particularly cold periods, where the external ambient temperatures are low, condensation may still form on external walls as the insulation levels may well not be thermally able to cope with the difference between the internal and external temperatures.

How can you prevent condensation

Provide ventilation so that moist air can escape.

- a. Good ventilation of the vehicle when cooking or when drying clothes, footwear or pets is essential. Observe when windows begin to show signs of misting and increase ventilation by opening slightly by 1cm or opening a roof vent, as these will help, but keep the habitation door closed as much as possible to retain heat.
- b. If drying damp clothes or towels, open a window to ventilate the area and allow the moist air to escape.
- c. Try to make sure that the caravan is partially heated. It can take a long time for a cold caravan to warm up, so it is better to have a small amount of heat for a long period than a lot of heat for a short time.

CONDENSATION AND INTERIOR MAINTENANCE

- d. After showering, keep the bathroom window or skylights open, and shut the bathroom door long enough to dry off the room.
- e. Fixed ventilation is provided in the vehicle, specifically through the floor, it is important not to block these.
- f. Electrical heating is dryer than gas heating, and introduces less moisture into the atmosphere. Do not use additional portable paraffin or flue-less gas heaters at all.
- g. If left unoccupied and unheated for long periods of time the temperatures can soak down thermally into the entire product and become very cold. Whenever possible, put the heating on at a low level before use by pre heating in cold weather.
- h. Even with reasonable ventilation it is likely if the temperature is less than 5°C and the humidity is high that condensation will occur. Ideally the temperature should be kept about 20°C when occupied.

Mould Growth

Any sign of mould growth is an indication of the presence of moisture and if caused by condensation gives warning that heating or ventilation may require improving.

New vehicles

New products take a long time before they are fully 'dried out' because of the moisture in the materials used during manufacture. While this is happening extra heat and ventilation will be required.

Corrosion

Your caravan has been designed and built using corrosion resistant materials (e.g. aluminium panels, stainless steel fixings, hot dip galvanised chassis and powder coated extrusions), which if looked after will extend the life and aesthetics of the product in normal service. In certain conditions, for example, if sited for extended periods in close proximity to sea and sand spray, the caravan may experience premature ageing and/or corrosion of the vehicle than it would under normal conditions.

To help prevent this, we advise regular cleaning and application of a good quality external car polish. For extended periods (where the vehicle is not in use), we recommend the use of a well fitted breathable vehicle cover as protection from harsh, or coastal elements.

Caravan interior

Follow these guidelines to ensure your investment is receiving the very best attention.

Side Walls, Roof Lining

A simple wipe over with a damp cloth and a very mild detergent is all that is needed.

Soft Furnishings

Should be vacuumed occasionally to remove grit and sand and help to keep its smart appearance and ensure long life. The upholstery can be cleaned with a mild, reputable upholstery cleaner. It is recommended that the curtains and pelmets are specialist cleaned only. The foam used in cushions is manufactured to meet fire regulations. It requires time to return to its normal position after prolonged use.

Swift Shield Fabric (optional)

The Swift Shield fabric fitted to some Swift Group products is a luxury stain resistant durable fabric using Aquaclean® technology. This is a revolutionary fabric treatment that allows you to clean stains using water only. This provides you with simple fabric maintenance in the minimum amount of time.

Cleaning Instructions

Aquaclean® helps to remove the majority of household stains (wine, ink, sauce, fat, mud, chocolate, cream, etc.) in three simple steps:



1. Remove any excess residue on the upholstery



2. Apply water over the stain, either directly or using a damp cloth. Wait a few seconds.

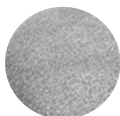

3. Press down over the stain with a damp cloth and rub gently over the fabric in circular movements. If the stain does not come off completely, repeat the process as required.

For further details and stain cleaning demo videos visit the Cleaning Gallery on the Aquaclean® web site: <https://www.aquaclean.com/en-es/index>

Aquaclean fabrics cannot accept any responsibility for misuse of the fabric by allowing bleach or dissolvent substances coming into contact with it.



Work Surfaces

You should not stand very hot items on any of the work surfaces, especially models with polycarbonate moulded sinks and drainers.

Kitchen Equipment

All the thermoplastic parts in these areas have easy clean surfaces. To ensure long life and to prevent damage you must not use any cleaning materials at all and ensure water temperatures do not exceed 70°C (putting cold water in first is suggested). After every use it is essential that you rinse with clean water only and wipe with a soft damp cloth. Failure to follow these simple instructions may result in premature failure or cracking which will not be covered by any guarantees (including extended warranties).

Bathroom/Shower

These products should be cleaned immediately after use. Apply a warm, mild soapy water solution with a soft cloth and rinse with clean water immediately. Abrasive materials must never be used.

Furniture

A simple wipe over with a damp cloth should be all that is required. Polishing with a proprietary brand of wax polish enhances and maintains furniture in showroom condition.

It must be remembered that because the frames of the doors are made of ash, which is a natural product, they can be affected by temperature and humidity and may bow under certain conditions. As conditions change they should revert to their original positions.

Cutting Board

You should not stand hot items on to the removable plastic cutting board. To wash use only warm soapy water, do not use chemicals and bleach.

WINTERISATION

Winterisation

The Swift Group recommends the following winterisation points for customers:

Servicing

Arrange (in advance) the yearly service and habitation check, if the caravan's next service is due while the vehicle is stored.

Electrical

If vehicle is being stored while connected to 230v Mains Hook-up:

- Ensure that the leisure battery is connected and the 20A local fuse(s) is connected.
- The isolator switch on PSU should be in the 'ON' position, however, the control panel should be switched 'OFF'.
- Vehicles can be left in this condition for extended periods, with the charger operating to maintain the battery. However, periodic maintenance and inspection is recommended, this should include the battery condition.

If vehicle is being stored not connected to 230v Mains Hook-up:

- Connect caravan to mains hook up with charger on for at least 24 hours prior to placing caravan in storage.
- Ensure the isolation button on PSU is in the 'OFF' position.
- Ensure leisure battery is connected and 20A local fuse(s) is in place, if an alarm or tracker device is fitted.
- The alarm will eventually drain the leisure battery - we recommend regular (monthly) inspection / re-charging of leisure battery via appropriate means. A solar panel can be used to provide an alternative power source and extend the time between leisure battery requiring a re-charge.
- Remove the leisure battery and store in a dry place, if an alarm or tracker device is not fitted.

- The battery should not be adversely affected by winter temperatures but the level of charge should be maintained to maximise the life span of the battery. This can be achieved using an automotive type battery charger as and when required.

Gas system

- Ensure the gas supply is isolated at the gas bottle, and ensure that the gas manifold taps are off.
- Check the age and condition of the high pressure gas hose and regulator, and replace if required.

Appliances

- Check the battery expiry date on the smoke alarm and replace or remove as required.
- Ensure the fridge is turned off.
- Clean the inside of the fridge.
- Prop the fridge door open, and if possible, the internal freezer compartment door for ventilation.
- Fit fridge vent winter covers (if available).
- Ensure all hob / oven / microwave surfaces are clean.
- If the caravan is going to be left connected to 230v supply while not in use, ensure the microwave is unplugged.
- Empty the toilet cassette.
- Drain the toilet reservoir.

Empty the fresh water tank using the drain tube / fresh water tank level indicator (level indicator on electronic models only).

Pull the lever indicator / drain tube down from top plug position and outward through door opening to drain water from the tank.

Empty the water fill funnel by pulling the bottle away from tank.

Remove the small water cap on the filler bottom, allowing water to drain from the water funnel. (Not C-200 toilet).

Do not tighten caps, this helps in keeping unit dry. The pour out spout and vent plug can be removed. Seals should be lubricated if necessary with acid-free Vaseline.

Exterior (Body / Chassis)

- Ensure that all windows, skylights and access doors are closed and secured.
- Ensure all fixed ventilation points (high and low) are clear from debris and obstructions. It is advised that fixed ventilation points are checked and cleaned (if necessary) on a regular basis using a small brush and a domestic vacuum cleaner
- Ensure the vehicle is not parked where falling debris (i.e. leaves, tree sap) could cause damage.
- Avoid leaving the vehicle parked in soft ground, long grass or a potential area where standing water may form.
- Lubricate relevant points on the chassis.
- Remove road wheels, using the correct jacking points and suitable axle stands, or if being left on road wheels rotate wheels (every two weeks) and ensure the correct tyre pressures are maintained.
- A purpose made cover maybe used, but please ensure the cover is a good fit, breathable and securely fitted.
Note: A poorly fitted cover can rub and damage the bodywork. Non-breathable covers will encourage mould to grow and if fitted prevent the operation of a roof mounted solar panel (model specific)

Interior (Furniture / furnishings)

- Open all lockers and internal doors, to ensure good circulation.
- Remove cushions and store them in a dry location or ensure all cushions are placed in a well ventilated area.
- Close all blinds and curtains. Customers are reminded to check the tension on blinds after storage if left closed for long periods.
- Thoroughly ventilate the caravan by opening doors or windows periodically.
- Placing water absorbent crystals in the van during the winter months, will help reduce moisture levels and mould growth.
- We do not recommend leaving portable heaters in the van unattended.

Water system

Water expands as it is frozen, and so trapped water, when it expands, can damage the tap / valve / pump or pipe it is trapped within. For this reason, (in addition to reasons of hygiene), the water system should be fully drained when not in use, particularly in colder weather.

Follow the basic steps outlined below to remove water from the system (current caravans):

- Disconnect any external water source, external submersible hose or pump.
- Locate the 'Yellow' drain valve, which is floor mounted and will be next to the water heater. Move the lever on this valve to the vertical.
- Open one of the taps (the kitchen tap is the most convenient) to the middle (hot and cold mix) position.
- Turn on the pump using the button on the control panel, and leave the pump running until water no longer flows from the tap.
- Open the vanity tap and shower tap mixer, again to the centre hot and cold position and leave them open whilst the caravan is out of use.
- Also remove the shower head, and leave the head in an upright position.
- If present connect the external shower handset and fully open to drain, disconnect and store.

WINTERISATION

After a short while the majority of water will have left the plumbing system. At this point however it is still important to ensure that the pump itself is 'dry'. During this part of the winterisation, a suitable absorbent cloth or container should be used to catch a small amount of spilled water that will result.

The pump should be disconnected on the output side of the pump, and run for a short while to expel any water contained within the pump body and filter. This is also a good time to disassemble and clean (if necessary) the filter fitted on the input side of the pump.

The easiest method of disconnecting the pump is to remove the quick-release tabs from the Posi-flo type pump (details of releasing push fit plumbing connections can be found in this handbook).

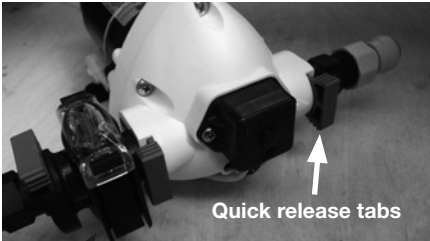

Water filter

Quick release tabs

Galvanised Parts

Wet storage stain (white rust)

Hot dip galvanising has been used for many years throughout the automotive industry and is widely regarded as one of the best forms of corrosion protection.

When the steel is withdrawn from the galvanising bath it has a clean, bright surface. Over a period of time this changes to a dull grey colour as the surface zinc reacts with oxygen, water and carbon dioxide in the atmosphere to form a tough, stable, protective layer.

During this time, if galvanised items are stored in damp or wet conditions, where there is little or no air movement then the zinc will continue to react with the moisture that is present. In so doing the zinc will produce excessive amounts of zinc hydroxide. This is seen as a bulky white deposit on the surface of the galvanising and is often referred to as wet storage stain (white rust).

You can help to prevent wet storage stain (white rust) occurring. You can do this by washing the chassis with clean water. You must then allow an adequate flow of dry air to ensure that they dry off completely.

The caravan should not be parked on long grass where the air flow around the chassis is hindered and the dampness retained. It is most likely that the chassis will rapidly show signs of wet storage stain under these conditions.

It is also very important to do this during the winter months to ensure all salt deposits from road spray are completely rinsed off.

AL-KO chassis

Manufactured from high quality steel, the chassis has extra deep sections to provide strength at points of maximum stress. Large elongated holes are punched in the longitudinal chassis members, to reduce weight to a minimum. Each hole incorporates a return flange to maintain the required strength and provide rigidity in the extra deep sections.

The chassis frame is of a bolted construction which allows replacement of individual parts should the need arise.

The chassis is Hot Dipped Galvanised. This is regarded as one of the best forms of corrosion protection. It does however require minimal maintenance in certain circumstances and should, if properly maintained, last the lifetime of the vehicle.

When new, the chassis is of a bright and shiny appearance. As the galvanising cures during the initial 2/3 month period, this will gradually change to a medium/dark grey colour. This grey finish is the ideal, giving the correct protective coating. During this curing period the surface should be protected to avoid possible wet storage stain, in the form of a soft, light coloured, porous, oxidation layer. If the chassis members are in contact with any salt deposits from roads this should immediately be washed off with a high pressure washer. Salt attracts moisture allowing the surfaces to remain wet, this prevents curing and also allows formation of wet storage stain.

It is recommended that the chassis/ components are washed off, using a pressure washer on an annual basis (especially after winter usage), to avoid undesirable build up of salt and dirt deposits.

The galvanised chassis should not be painted or subjected to any other protective treatment.

Should the galvanising become superficially damaged exposing the steel core, this should be cleaned and treated with a Cold Galvanising Spray obtainable from vehicle accessory outlets.

AL-KO ATC CONTROL SYSTEM WHERE FITTED

Display Colour	ATC Condition	Diagnosis	What to do	Outcome	Status
Green	ATC Active	Everything OK			
Green Flashing	ATC Active	Self test incomplete	Drive forward to detect movement to complete self test and recheck LED.	Green (Constant)	Ready for journey
Red	ATC Inactive	Possible to continue journey	Remove 13 Pin plug and wait 5 seconds. Reconnect plug.	Green Red	Ready for journey ATC Error log file memory exceeded. Caravan can be towed, but ATC will not apply caravan brakes in the event of instability. See below *
Red flashing	ATC has detected a fault.	Do not continue a fault with ATC connected	Remove 13 Pin plug and wait 5 seconds. Reconnect the plug	Green Red (flashing)	Ready for journey ATC faulty, and cannot be driven. Remove push-rod as shown on page 131. Consult AL-KO, see back page for details.
LED not working	ATC has no power	Check push rod position as shown on page 5 of the ALKO ATC manual before continuing journey.	Remove 13 Pin plug and wait 5 seconds. Reconnect the plug. Check for constant live - refer to system requirements.	Green LED not working	Ready for journey If power OK, check push rod position: Red line visible - do not drive vehicle. Red line not visible - possible to continue journey but consult AL-KO see back page for details.

Damage to chassis members through impact etc, MUST NOT be straightened or welded. Damaged chassis members MUST be replaced.

Drilling or Welding of Parts or Accessories

The chassis is designed and built to precise tolerances and must not be drilled or welded (except in accordance with certain AL-KO Accessory Operating Instructions). Failure to comply will invalidate all warranties.

AL-KO ATC trailer control system (where fitted)

AL-KO ATC is an electronic, emergency Control system for caravans and trailers. It automatically recognises critical swinging motions and applies the caravan brakes accordingly to regain control of the caravan and car.

General notices

Read and act in accordance with the following operating instructions before attempting to use AL-KO ATC. AL-KO ATC is a safety related product and, therefore, should only be fitted by an authorised AL-KO trained technician with experience of working with electrical installations. Any evidence of removal or disassembly, other than by trained technicians, will immediately invalidate the product warranty.

Safety Information

AL-KO ATC is a passive safety product that activates the braking system on the caravan in unsafe driving conditions. The driver has a responsibility under law to ensure that the elements of towing safety are met, including driving within the legal speed limit, consideration of road, weather and other traffic conditions, correct loading and coupling of the caravan.

AL-KO ATC is designed to fit only on AL-KO Chassis and is not suitable for non AL-KO Chassis. AL-KO ATC only functions on caravans with a rigid towbar. The electrical connection between the towing vehicle and caravan must be in good working order.

ATC draws power from the towing vehicle towbar and requires connection to either: Twin * ATC stores operating errors in a log file which over time will become full and will result in the solid red light appearing. This needs to be erased and can be done easily by connecting the caravan to a 12 volt supply for a period of 12 hours. The power required to carry out this function is minimal. Most occurrences of these errors are due to power supply problems to ATC which could be due to low voltage, or an intermittent power supply from the towbar.

Maintenance and Warranty

ATC is maintenance free and requires no servicing. In case of any damage to ATC, please contact AL-KO. ATC is a sealed unit and any evidence of removal of ATC or the component parts including outer casing and fixings will immediately invalidate any product warranty.

If ATC is fitted as standard by the vehicle manufacturer then ATC is covered for the same duration of the vehicle warranty or whichever is longer.

If ATC is subject to a call out under warranty and found to comply with the relevant specification or standard, then the cost of any testing or call out charges will be borne by the customer. We reserve the right to request credit card details to cover payment in advance.

Removal of a push rod



Using a 17mm spanner, slacken locking nut on push rod away from Bowden cable abutment as directed above.

AL-KO ATC CONTROL SYSTEM



As an emergency system, AL-KO ATC automatically safeguards against a number of critical driving conditions. When used in conjunction with AL-KO AKS, there is no safer package for towing a caravan.

A safe driving style and correct loading combine with AL-KO technology to ensure optimum safety and unparalleled towing stability.



Unscrew push rod from brake rod and slide it from the guide tube. Remove the locking nut from push rod using two 17mm spanners.



Re-apply the removed locking nut onto brake rod thread to secure ball nut as shown above. ATC is now deactivated.

The AL-KO formula optimum safety

The AL-KO formula for optimum safety is a combination of industry leading technology that ensures the safest possible driving conditions for caravan owners. The formula provides total confidence and control when towing a caravan.

7-Pin Connection

ATC can be connected via the auxiliary 12S (white/grey) plug and requires power on Pins 4 (permanent supply) and 3 (earth). Please ensure that your vehicle towbar is correctly connected to ensure correct ATC operation. This can be checked with the use of a multimeter. Important - A 20 amp fuse is required for the constant 12V supply to Pin 4 on the 12S socket. If only a single fuse is fitted to supply both Pins 4 and Pin 6, the power supply capability of the installation must be checked and a minimum fuse rating of 25 Amps must be used.

13 Pin Connection

ATC can be connected via the 13-Pin plug and requires power on Pins 9 (permanent supply) and 13 (earth). Please ensure that your vehicle towbar is correctly connected to ensure correct ATC operation. This can be checked with the use of a multimeter.

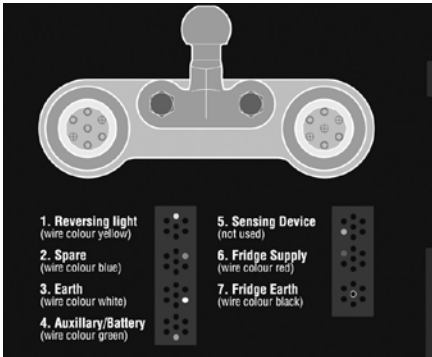

Operating instructions

After coupling the caravan correctly to the towing vehicle, connect the 12N & 12S plugs or the 13 Pin plug to the towbar.

Upon connection, ATC will carry out an initial self test and the LED light on the front fairing will light up RED. During the self test, the sound of the push rod moving inside ATC can be heard. When the self test is complete, the LED will turn GREEN or flashing GREEN to signal that ATC is active. If the LED does not change to green, then ATC is not functioning correctly. The table provided on page 130 details what to do in this case. Prior to commencing any journey, ensure that the

caravan lighting is fully operational and check the vehicle is loaded appropriately, the nose weight and tyre pressures are correct, and confirm that the caravan is coupled to the vehicle with the breakaway cable correctly applied. Always re-check the ATC LED is green after any interval during a journey, such as a service station break.



Troubleshooting

Should you experience a fault with ATC, the LED light on the fairing will change colour. Therefore, refer to the table on page 130 and follow the instructions. If no illumination of the LED is evident, refer to system requirements on page 130 and check towbar wiring for permanent supply.

In the unlikely event that you receive a red flashing LED light and disconnecting and re-connecting the power does not alleviate the problem, check the push rod position as detailed below. Locate ATC on the axle and check the position of the push rod. If no red line is visible, ATC is not active, and can be driven. However, we recommend that you contact AL-KO at the earliest convenience.

If the red line is visible on the push rod, as shown on the left, the caravan should not be moved. The push rod needs to be removed to deactivate ATC. Using two 17mm spanners, the removal process is as shown opposite.

Note: Please be aware your ATC is live all of the time your 13pin connection is made. If the car and caravan are stood for a long period of time (e.g. ferry crossing) the ATC will continue to draw power from your battery.

LOADINGS

Loadings on Coupling Heads, Overrun Assemblies and Axles

The permitted 'nose' weights of the coupling head/stabiliser, overrun assembly and drawbars, must never exceed the lowest value stamped on the assemblies.



Fig. 1

The maximum axle loading is that stamped on the plate (Fig. 1 example axle plate) located in the centre of the axle, facing rearwards.

Note: Do not attempt to remove as this will void the plate.

The third line down marked "Capacity" is the maximum permitted axle loading and must not be exceeded.

The caravan manufacturer may have stated a lower maximum loading weight on the plate fitted adjacent to the entrance door, this then becomes the maximum permitted load and must not be exceeded. We recommend you record the Axle details for future reference.

It may be possible if required for the caravans MTPLM to be upgraded.

Your caravan dealer will require the following details from the axle plate.

(Example of information ref Fig 1)

- Order - CHA402248
- Qty - 1 of 2
- Date - 3 May 05
- Type - B850-10
- Capacity - 1000E

Please consult your Swift Group Dealer to confirm if this is possible.

Loading

Loads to be carried in the caravan should be placed directly over, or as close as possible to the axles, otherwise the handling will be impaired. Maximum gross weight, as advised by the caravan manufacturer, must not be exceeded without approval from AL-KO.

Maximum loading is defined as the difference between ex-works weight and the permitted total weight.

Load Too Far Forward (Fig 2)

Steering and braking ability reduced. Increased loading on the rear axle and chassis of the tow vehicle.



Fig. 2

Load Too Far Back (Fig. 3)

High skid risk together with poor braking effect.

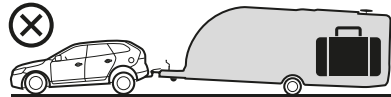

Fig. 3

Load Over Axle (Fig 4)

Optimum road holding together with maximum braking effect. Exceptionally heavy loads should be placed directly over the axle.

Attention should be paid to the legal regulations regarding the permitted pressure exerted by the towbar on the towed unit.

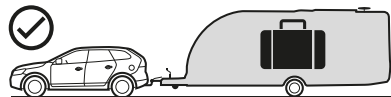

Fig. 4

Axle types

Safety Precautions

No welding is permitted on AL-KO Axles

It is important that the wheel and hub / brake drum are compatible. This means that the PCD, wheelbolts and inset must all be compatible with both the hub/brake drum and the wheel rim.

Particular attention must be paid to the recommended torque figures for the wheelbolts (see pg 33).

The axle type details shown on axle type plates must not be obscured or made illegible by application of any additional surface finish.

Operating Instructions

Service Brake

When the towing vehicle is braking or travelling down hill, the overrun device shaft is pushed in (dependent on the magnitude of the thrust on the shaft) and presses on the overrun lever. This acts on the bowden cables and expander mechanism, which in turn expands the brake shoes applying the wheel brakes.

Hand brake

With the gas strut version, pull the handbrake lever until upright. With the spring cylinder version, pull the handbrake lever right up to the last tooth. The caravan is then braked.

⚠ WARNING: Please note that with the handbrake fully applied, the caravan/trailer is able to move backwards by 25 cms until the spring cylinder/gas spring takes effect.

Maintenance and Cleaning

Maintenance of Euro-Plus/Euro-Compact and Euro-Delta.

The above semi-trailing axles come fitted with maintenance free wheel bearings (greased and sealed for life) and no adjustment is necessary.

Note: The hub bearing is not protected against water ingress. Check wheel brake linings for wear every 10,000 kilometers (6200 miles) or every 12 months via the inspection hole

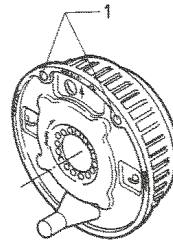

Fig. 5

(Fig. 5/Item 1). Adjust if necessary. Where continuous travel in hilly regions or high mileage is experienced, earlier inspection and adjustment may be necessary.

Note: The flanged hub-nut, located under the dust cap, used to keep the brake drum in situ, is a ONE-SHOT NUT (ie. must only be used once). If removed it must be replaced with a NEW flanged nut - torqued to 290 ± 10 Nm (214 ± 7.5 lbs/ft). A small amount of special mineral grease, available from AL-KO must be applied to stub axle thread prior to fitting the new flanged nut. After fitting excess grease must be removed with white spirit.

The rear hexagon cap head bolt located under the black plastic cap MUST NOT BE DISTURBED under any circumstance. Interference with this nut will result in immediate tyre wear and damage to the braking system and WILL INVALIDATE ALL WARRANTIES. Should the rear nut accidentally be disturbed then the complete axle must be returned to AL-KO for resetting of the toe-in and camber.

AXLE

No attempt should be made to remove the bearing. In the event of damage to the bearing or drum, only the drum complete with bearing and circlip will be available as a spare. No grease is used in the hub other than the mineral grease on the stub axle. No grease should be placed in the DUST cap. This is not a grease cap as used in all previous hubs

Spare parts

Spare parts are safety critical parts! For this reason when fitting spare parts we recommend the use of original AL-KO parts or those parts that they have explicitly approved. The reliability, safety and suitability of parts designed especially for their products, has been determined using a special test procedure. In spite of constantly monitoring the market they are unable to assess or vouch for other products.

If repair work or servicing is required, AL-KO have a large network of AL-KO service stations throughout Europe.

To establish the correct spare parts required for your axle you should always quote the axle type (axle identification plate Fig. 1, page 134) and Spare Part Identification no. (ETI No.), which will be stamped onto the wheel brake or on the identification plate (Fig. 6). Please establish these numbers before contacting AL-KO or a Service Agent.

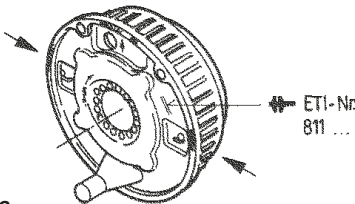

Fig. 6

The AL-KO rubber suspension axle has been designed and developed to suit all types of road conditions and is maintenance free.

Three rubber elements are contained within an hexagonal axle tube. These provide suspension and have inherent damping characteristics.

Figs. 7, 8 & 9 show the deformation of the rubber elements at the extremes of suspension movement.

The axle is designed to ride with the suspension drop arm at, or slightly below, the horizontal position.

For Trouble Shooting & Fault Finding please see Table 1 on page 143.

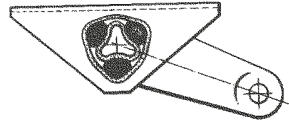

Fig. 7

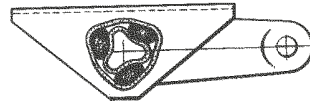

Fig. 8

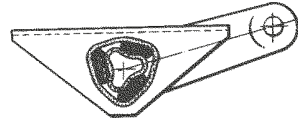

Fig. 9

AL-KO braking system adjustment

1. Ensure the towing shaft with coupling head is pulled FULLY FORWARD. (Fig. 10).
2. Release the handbrake to the FULLY OFF position. If the handbrake will not go down the whole way because of the fairing or any other obstruction; then the fairing must be cut away and/or the obstruction removed to achieve this desired position. It will not be possible to set up the braking system properly when the handbrake is not in the FULLY OFF position. (Fig. 10).
3. Jack up one side of the caravan, using the AL-KO Side Lift Jack System. (see Jack Operating Instructions).
4. Remove the inner plastic bung from the backplate to expose the "starwheel" adjuster access. (Figs. 10 & 11).

5. ALWAYS rotating the road wheel in the forward direction - NEVER backwards; adjust the starwheel with a suitable screwdriver, in the direction of the arrow embossed on the backplate until there is resistance in the wheel rotation. (Fig. 11).
6. Slacken off the starwheel adjuster until the road wheel turns freely in the FORWARD direction. (Fig. 11).
7. Check the adjustment at the end of the brake cable where it is secured to the abutment (bracket), welded to the centre of the axle.

When the inner cable is pulled out it should extend between 5 and 8 mm. (Fig.12). (On tandem axles a double abutment (bracket) is fitted to the front axle ONLY).
8. Repeat for other wheel or wheels.
9. Ensure the balance bar (compensator) is being pulled evenly (Figs.10 & 12). Excessive movement to this bar (double on tandem axles) would indicate possible incorrect adjustment (if appropriate, repeat step No. 7 - Fig. 12).
10. Check the brake rod support bracket, (fixed to the floor) IS supporting the brake rod evenly. The brake rod MUST ALWAYS run straight, NEVER bent or curved under any fittings. On tandem axles, using the double balance bar, a brake rod support tube (ALKO Part No. 228827) MUST ALWAYS be fitted on the end of the brake rod, passing through the centre aperture on the abutment.
11. Remove the slack in the brake rod by adjusting the long ball nut, rear of the balance bar, ensuring the overrun lever makes contact with the end of the towing shaft. Note! Over adjustment to the long ball nut (Fig. 12/Item 2) could induce movement of the inner brake cable, reducing the effective clearance of the brake shoes. If the overrun lever will not make contact, it is possible the two lock nuts, forward of the spring cylinder, are incorrectly adjusted. Loosen the nuts and adjust brake rod as above (Figs. 10 & 12).
12. OVER ADJUSTMENT of either the wheel brakes or linkages, will result in difficult reversing causing the wheels to “lock-up”.
13. When parking, the handbrake lever MUST ALWAYS be engaged into the fully upright position (90°). If difficulty is experienced in this operation, try easing the caravan backwards with one hand while engaging the handbrake fully with the other. This manoeuvre should not be attempted on a rearwards facing slope. In this case wheel chocks should be used combined with the handbrake. See page 142 for all handbrake operations.
14. Finally, if the road wheels have been removed, re-tighten using a calibrated Torque Wrench (see Changing a wheel). Remember to over-tighten is just as dangerous as to under-tighten, as this can distort the wheel rims. Avoid the use of power wrenches.

⚠ WARNING: The torque settings should be rechecked regularly. Wheel bolts should NEVER be lubricated.

AL-KO BREAKING SYSTEM ADJUSTMENTS

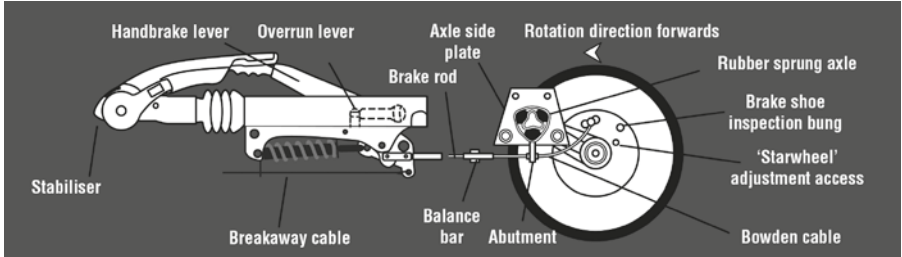

Figure 10 Brake Linkage

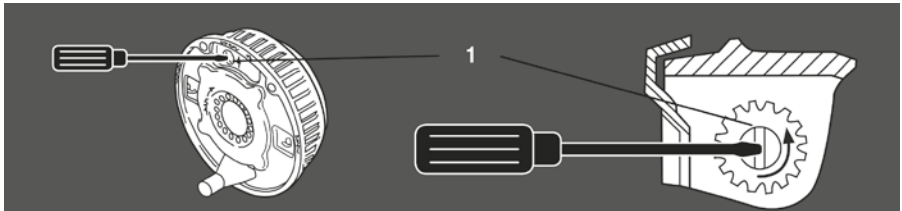

Figure 11 Adjusting the Starwheel

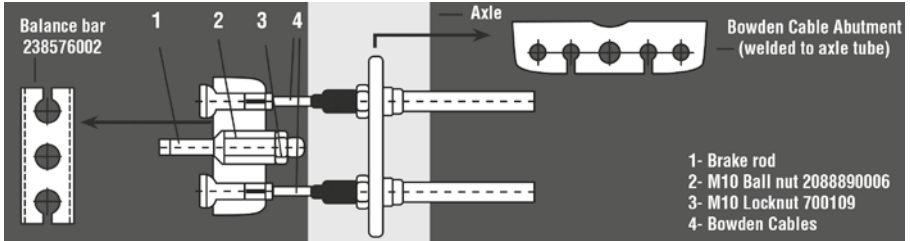

Figure 12A Standard Brake Linkage

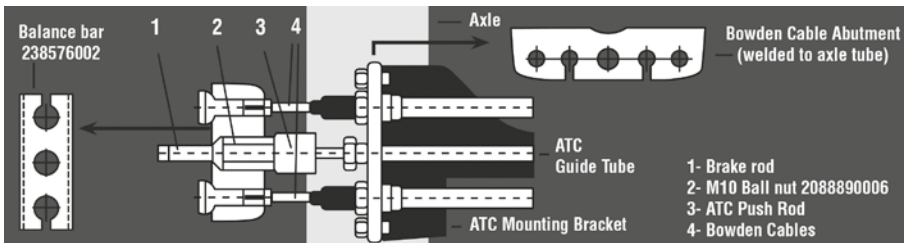

Figure 12B Brake Linkage with ATC Fitted

Stabilisers and coupling devices

SAFETY PRECAUTIONS

Always ensure that the coupling head is properly connected to the tow vehicle's towball every time you couple up. If this procedure is not carried out correctly, the caravan/ trailer may become detached from the towing vehicle! Maximum possible articulation of the coupling head must not exceed $\pm 25^\circ$ vertically and $\pm 20^\circ$ horizontally - see Fig 13.

If exceeded, components will be overloaded and the operation of the assembly adversely affected!

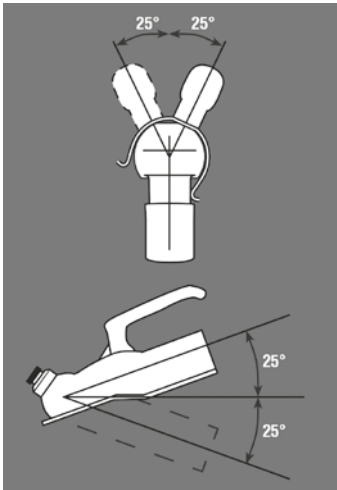

Figure 13 - Maximum Articulation of Coupling Head

AK161 COUPLING

AK161 Coupling

Operating Instructions

Coupling Up



Figure A

Open coupling handle. To do this lift the coupling handle (fig. A) diagonally upwards.

The coupling mechanism has a fixed open position, i.e. as long as the coupling head is not placed on the ball the coupling will remain open. When the tow ball is not inserted a red section is displayed.

Put the open coupling onto the tow ball. The coupling handle will move into the horizontal position and indicate that a secure connection has been created. In the interests of safety press the handle down by hand.

The coupling head is correctly connected when the green safety display is pushed out by the ball on the towing vehicle, and is therefore visible.

Caution

If the coupling head is not correctly hitched onto the tow ball, then the caravan/ trailer can become disconnected from the towing vehicle.

Uncoupling

Open the coupling handle and lift the coupling head from the tow ball by using the jockey wheel winding handle.

Wear indicator



Figure B

A wear indicator on the coupling head (fig. B) shows whether the wear limit of the towing vehicle's tow ball or the trailer coupling has been reached. For this purpose, hitch up the trailer to the tow ball and drive the unit for approx. 500m This will set the coupling head adjustment. Following this, check the wear indicator as follows:



Figure C

If the '+' symbol is indicated both the trailer towing device on the vehicle and the ball coupling on the trailer are not worn. (Fig. C)



Figure D

When the '-' symbol is indicated on the coupling this indicates that the trailer towing device on the vehicle or the ball coupling is worn. (Fig. D)

This could be caused by the following:

- Tow ball has reached the lowest wear limit of 49.61mm dia.
- Both coupling head and tow ball are showing sign of wear.
- Tow ball is in good condition with 50mm dia., but the coupling head is showing an excessive level of wear.

Caution

Under these circumstances, the coupling head can become detached from the tow ball and the caravan/ trailer can break away from the tow vehicle. The coupling head and tow ball must therefore be checked IMMEDIATELY before future use. Any faulty parts must be changed IMMEDIATELY.

All maintenance work should be carried out by AL-KO Approved Workshops.

Overrun Device

In the importance of safety, please familiarise yourself with the operation of this overrun device BEFORE using your caravan.

Safety Precautions

When parking your tow vehicle and caravan on site, you must apply the caravan handbrake. If the unit is parked but disconnected from the tow vehicle, it is strongly recommended that each wheel is chocked using AL-KO or suitable wheel chocks.

Caution: Please note when parking the caravan, the wheelbrake auto reverse mechanism will allow the caravan to travel backwards for approximately 25 cm (please allow sufficient clearance when parking).

Operation

AL-KO overrun devices are a mechanical type, using a hydraulic damper.

Breakaway Cable

- Attach the caravan to the tow vehicle as described in AK161 coupling and AKS 3004 stabiliser sections
- Thread the breakaway cable through the breakaway cable guide provided (Fig 2) and connect it to attachment point provided on towing bracket (Fig 1). Please refer to 'Braked Trailers Use of Breakaway Cables' for further details.



Figure 1 Breakaway Cables.

Caution: The breakaway cable operates the handbrake (emergency brake), in the event of the caravan becoming detached from the towing vehicle during towing. For this emergency brake to work correctly, it is absolutely essential that the following points are observed:

1. The breakaway cable MUST run through the breakaway cable guide.
2. The breakaway cable MUST NOT be wrapped around the jockey wheel, as this disables the emergency brake (Fig 3).
3. The cable MUST run as straight as possible and not be restricted.
4. Ensure the cable is long enough to allow for cornering and will not become taut or snag during use, as this could result in the handbrake operating whilst towing.

Please refer to 'Braked Trailers Use of Breakaway Cables' information sheet, supplied with your caravan.

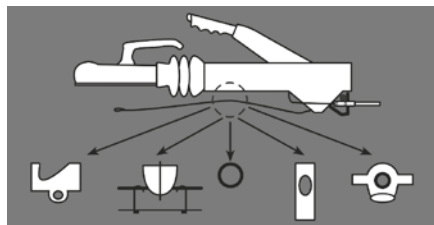

Figure 2 Breakaway Cables Guides.

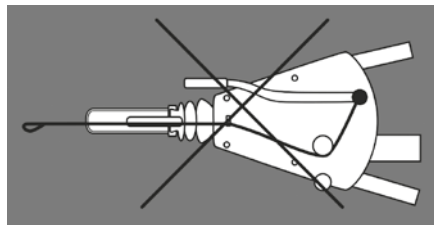

Figure 3 DO NOT wrap breakaway cable around jockey wheel.

AK161 COUPLING

SPARE PARTS

Spare parts are safety critical parts! For this reason when fitting spare parts in our products we recommend the use of original AL-KO parts or those parts that we have explicitly approved. The reliability, safety and suitability of parts designed especially for our products, has been determined using a special test procedure. In spite of constantly monitoring the market we are unable to assess or vouch for other products.

If repair work or servicing is required, AL-KO have a large network of AL-KO service stations throughout Europe. To establish the correct spare parts required you should always quote the model and type of overrun device in question along with the ETI No. which is stamped into the overrun device housing. The ETI number for the Euro Overrun can be found on the handbrake lever.

EURO-OVERRUN DEVICES FITTED WITH AK161 COUPLING HEAD

Connect caravan electric plug controlling lights and indicators etc. into towing vehicle socket. Wind the jockey wheel up fully and clamp securely in position, ensuring that it does not foul the brake rod or breakaway cable. Remove wheel chocks if fitted and stow safely.

Caution: Failure to comply with this could result in the brakes overheating.

Euro Handbrake

Ensure the handbrake is fully applied to ensure that the wheel brakes will be automatically re-applied should the vehicle start to roll backwards.

Caution: If the handbrake is not fully applied as detailed above, there is a danger that the caravan could roll backwards.

To release

Press the handbrake down until it is parallel with the fairing cover to ensure that the brake is correctly disengaged.

COMPLEMENTARY PRODUCTS**AL-KO Security Device**

AL-KO Security Devices provide a substantial deterrent against the theft of the caravan or trailer. They lock over the coupling handle, preventing unauthorised uncoupling.

Fitting the supplied Safety Ball into the coupling head when the Security Device is applied, prevents the caravan or trailer from being coupled to another vehicle.

The Security Device is manufactured from high density steel and is TUV approved. Visit www.al-ko.co.uk for more information.

Extended neck towball

Designed especially for use with the AL-KO AKS stabilisers the Extended Neck Towball has an extended machined neck to allow correct stabiliser articulation and clearances.

Trouble shooting & fault finding

Table 1 Axles

Fault	Cause	Remedy
Poor Braking	Linings worn or damaged. Brake Linings not bedded in. Brake set up incorrect.	Replace Brake Linings. Will pass after braking a few times. Reset Brakes as page 136 - 139 & ensure system is lubricated.
Difficulty in Reversing	Braking system set too tightly. Auto-Reverse lever too stiff.	Reset Brakes as page 136 - 139. Lubricate and free off Reverse Lever.
Brakes Overheating	Incorrect setting. Braking system not fully released. Overrun lever stuck. Damage or Corrosion to braking system	Reset Brakes as page 136 - 139. Check Handbrake has been released & the system is running freely. Lubricate and free off Reverse Lever. Check system as page 136 - 139 and repair or renew parts as necessary.
Handbrake Force Low	Incorrect setting of the brakes. Linings not bedded in.	Reset brakes as page 136 - 139 and lubricate as necessary. Will pass after braking a few times.
Uncomfortable ride or Uneven Braking	Loose braking adjustment. Damper defective. Axle shock absorbers defective.	Reset brakes as page 136 - 139. Check and replace damper if necessary. Replace shock absorber.

Table 2 Coupling Heads

Fault	Cause	Remedy
Coupling does not engage onto ball	Ball diameter too large. Ball could be damaged or deformed. Coupling head dirty or defective.	Change ball to correct size. Fit new ball. Clean & Lubricate coupling and replace if necessary.
Difficulty in Uncoupling	Ball damaged or deformed. Coupling damaged or deformed. Coupling head under pressure from damper.	Fit new ball. Replace if necessary. Pull forward a few inches to relieve pressure
Too much play in the coupling	Coupling damaged or deformed Ball too small	Replace if necessary. Fit new ball.

Table 3 Overrun Devices

Fault	Cause	Remedy
Poor Braking	Overrun shaft tight. Overrun shaft corroded. Body housing damaged.	Lubricate overrun shaft and replace any damaged parts.
Brakes Overheating During Towing	Handbrake not fully released. Braking system incorrectly set. Incorrect attachment of breakaway cable.	Release handbrake. Reset brakes as page 136 - 139. Ensure correct attachment as listed on page 24 or refer to Braked Trailers Use of Breakaway Cables sheet.
Handbrake Force Low	Defective gas strut. Incorrect setting of spring cylinder.	Replace gas strut. Reset spring cylinder as page 136 - 139.
Brakes Apply During Deceleration or Downhill Travel.	Overrun damper is defective.	Replace the overrun damper.

Accessories

Corner Steadies

Corner Steadies are as stated, for the purpose of steadying the caravan corners. They are **NOT JACKS AND SHOULD NEVER BE USED AS SUCH**. The screw and pivot pins should be lubricated periodically to ensure their satisfactory operation. (See also Jack Operation).

Shock Absorbers

All AL-KO chassis have pre-punched holes to accommodate Shock Absorbers, in front of the axle. On the Euro-Axle System, axle swing arms have a removable rectangular plastic cap exposing a slot to accommodate retro-fit brackets for the Octagon Shock Absorbers. Delta Axles have Shock Absorbers fitted as standard which **MUST NOT BE REMOVED**.

Road Wheels

The condition of wheels and tyres should be checked regularly, particularly for distortion of flanges and the wheel dish. Wheels that are damaged or distorted, or have wheel bolt seatings cracked or deformed must not be repaired or used in service - these must be replaced.

⚠ WARNING: The torque settings should be re-checked regularly.

Jacks

The Corner Steadies Should never be used to jack up the caravan. When jacking becomes necessary use the AL-KO Side Lift Jack or 2-Tonne Jack system.

Note: It is essential that the car and caravan are hitched together before commencing jacking. All AL-KO chassis from 1992 onwards have 2 holes punched in the chassis members, each side (rear of the axle); to accept the brackets for the Jack(s). Corner Steadies may be used for stability **ONLY**, when the caravan is in the jacked position. The caravan should never be lifted by jacking up under the chassis member.

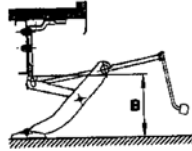

Side Lift Jack

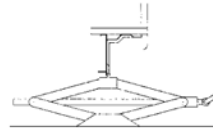

2 Tonne Jack

If working under the caravan in an elevated position, axle stands must be used for safety. Wheel chocks for the opposite wheel(s) are also advisable.

Jockey Wheel

Lubricate screw thread and wheel spindle periodically.



Corner Steadies

Corner Steadies are as stated, for the purpose of steadying the caravan corners. They are **NOT JACKS AND SHOULD NEVER BE USED AS SUCH**. The screw and pivot pins should be lubricated periodically to ensure their satisfactory operation. (See also Jack Operation).

Shock Absorbers

All AL-KO chassis have pre-punched holes to accommodate Shock Absorbers, in front of the axle. On the Euro-Axle System, axle swing arms have a removable rectangular plastic cap exposing a slot to accommodate retro-fit brackets for the Octagon Shock Absorbers. Delta Axles have Shock Absorbers fitted as standard which **MUST NOT BE REMOVED**.

BASECAMP TECHNICAL INFORMATION

Model	Basecamp	Basecamp Plus
Berths	2	2
Number of Axles	1	1
Internal Length (At bed box height)	3.42m / 11'3"	3.42m / 11'3"
Overall width**	2.28m / 7'6"	2.28m / 7'6"
Overall height** (including TV Aerial)	2.58m / 8'5"	2.60m / 8'6"
Maximum Internal Headroom	1.95m / 6'5"	1.95m / 6'5"
Overall Length	5.10m / 16'9"	5.10m / 16'9"
Mass in running Order (includes Tolerance)	891kg / 17.5cwt	916kg / 18.0cwt
MTPLM - (Lower Limit)	1002kg / 19.7cwt	1027kg / 20.2cwt
MTPLM - (Higher Limit)	1300kg / 25.6cwt	1300kg / 25.6cwt
Total User Payload	111kg / 2.2cwt	111kg / 2.2cwt
Personal Effects	111kg / 2.2cwt	111kg / 2.2cwt
Options	0.0kg / 0.0cwt	0.0kg / 0.0cwt
Type Size	185 R14C 102 Q	185 R14C 102 Q
Tyre Pressure at Lower Limit MTPLM	2.7 bar / 39psi	2.7 bar / 39psi
Tyre Pressure at Higher Limit MTPLM	3.7 bar / 54psi	3.7 bar / 54psi
Static Load on Coupling Head	100kg	100kg
Thermal Insulation Grade	THREE	THREE
Bed Sizes		
Front Double	198cm x 183cm - 6'5" x 6'0"	198cm x 183cm - 6'5" x 6'0"
Front Single (Nearside)	183cm x 69cm - 6'0" x 2'3"	183cm x 69cm - 6'0" x 2'3"
Front Single (Off Side)	183cm x 69cm - 6'0" x 2'3"	183cm x 69cm - 6'0" x 2'3"

* Estimated weight

**The dimensions given are approximate due to slight variations in suspension ride heights, loading conditions and tyre pressures.

Customers should verify the actual dimensions of their touring caravan before committing to anything that could be impacted by these dimensions

The masses are calculated in accordance to EU regulation 1230/2012 and NCC code of practice 304.

The Mass in Running Order (MRO) comprises:

1. The mass of the empty caravan as supplied by Swift including loose items such as the hook-up cable, kit bag, entrance step, manuals etc
2. 10kg allowance for LPG

The MRO is calculated with the fresh water tank, toilet flush tank and water heater empty. If you travel with water in the fresh water tank, toilet flush tank and the water heater the payload will reduce accordingly.

The personal effects is based on the number of berths and the length of the caravan and includes an allowance of 20kg for a leisure battery,

The Maximum Technical Laden Mass (MTPLM) is the maximum mass allowed when the caravan is fully laden.

WARNING: Under no circumstances should the MTPLM be exceeded.

Please note: Any dealer fit options will reduce the overall payload available to the user of the caravan.

If you require additional payload it is possible to upgrade the MTPLM to the upper limit. Please contact your Swift caravan dealer for more information.

Bulb Replacement (Interior and Exterior lighting)

All of the lighting inside and outside of the Basecamp, including road lighting, is 12v LED. The light fittings contain no user serviceable parts.

In the unlikely event of an LED failure, please contact your dealer to have the entire light fitting replaced. The fitment of exterior LED light must be undertaken by your dealer, to ensure all steps are undertaken to prevent water ingress.

WIRING DIAGRAM - ROAD LIGHTING

Road Lighting
 Swift Caravans 2019 Basecamp
 SARGENT ELECTRICAL SERVICES LTD Issue 2, 14/06/18

See separate sheet for cable colour chart
 Dual coloured cables show in primary colour
 White cables shown in Black
 Some vehicles feature LED light sources
 All road lights are LED

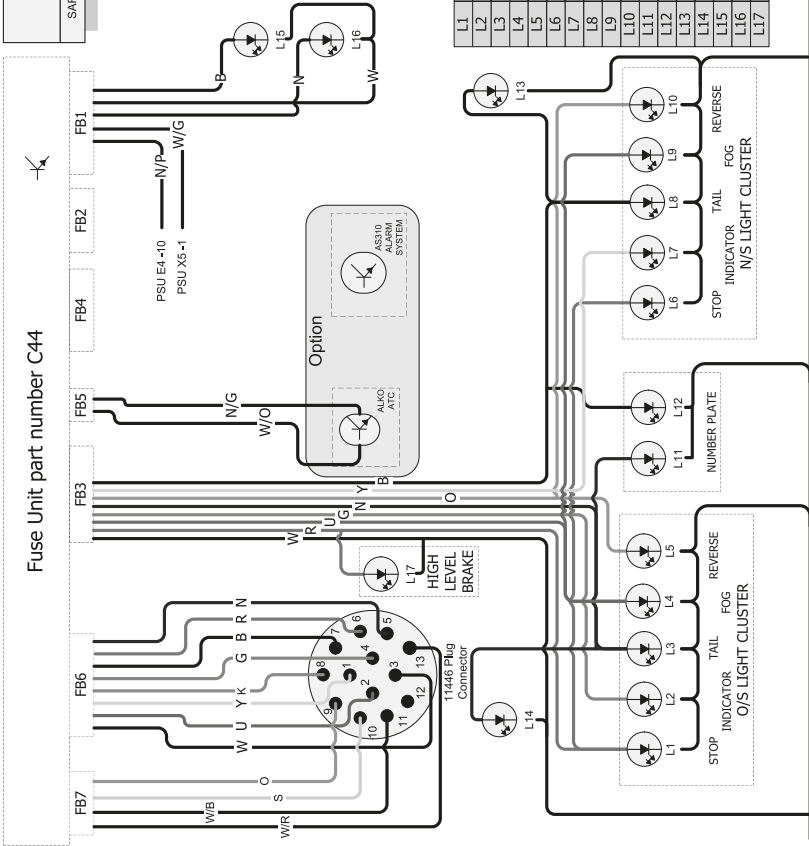

L1	Brake lamp	LED
L2	O/S Indicator lamp	LED
L3	O/S Tail lamp	LED
L4	O/S Fog lamp	LED
L5	Reverse lamp	LED
L6	Brake lamp	LED
L7	N/S Indicator lamp	LED
L8	N/S Tail lamp	LED
L9	Fog lamp	LED
L10	Reverse lamp	LED
L11	Number plate lamp	LED
L12	Number plate lamp	LED
L13	N/S rear marker lamp	LED
L14	O/S rear marker lamp	LED
L15	N/S front marker lamp	LED
L16	O/S front marker lamp	LED
L17	High level brake lamp	LED

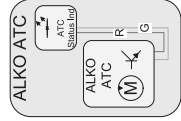

Pin3 Negative W

Copyright Sargent Electrical Services Ltd. 2017. All rights reserved. Subject to change without prior notice.

WIRING DIAGRAM - CONSUMER CIRCUITS

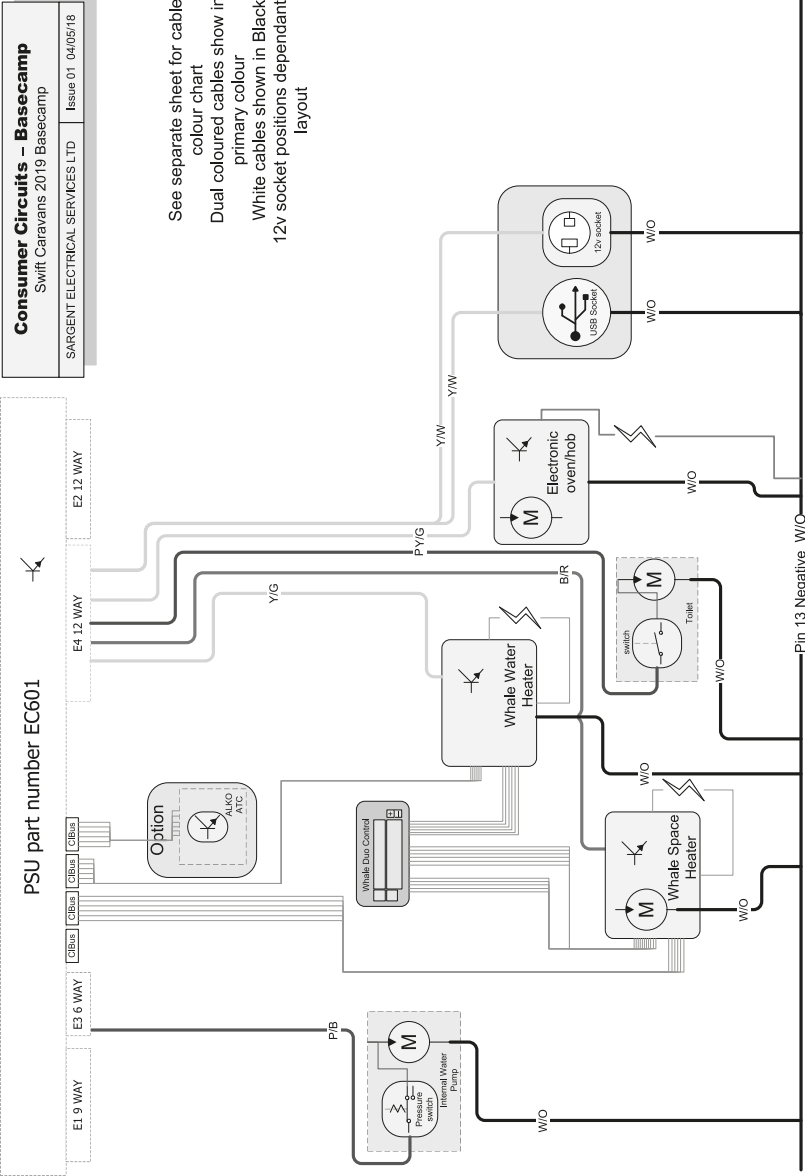

WIRING DIAGRAM - CONSUMER CIRCUITS ROOF

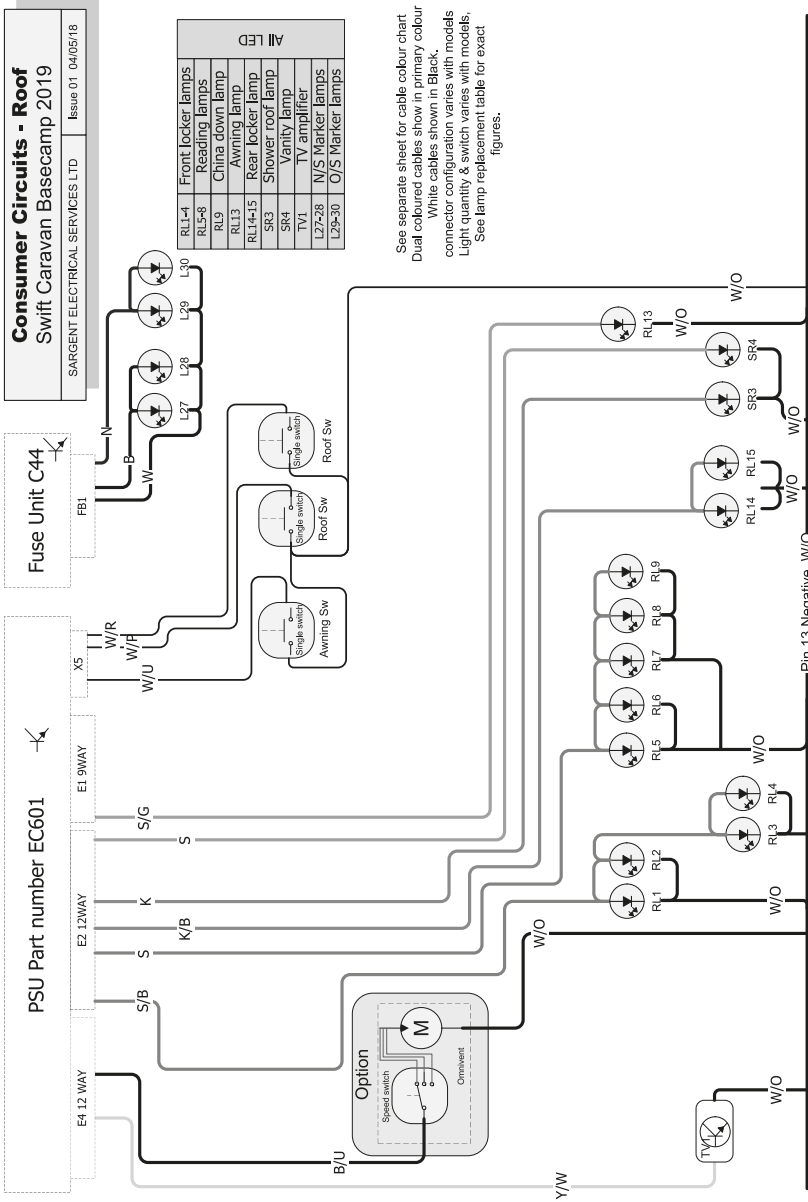

Copyright Sargent Electrical Services Ltd. 2017 all rights reserved. Subject to change without prior notice.

WIRING DIAGRAM - POWER CIRCUITS

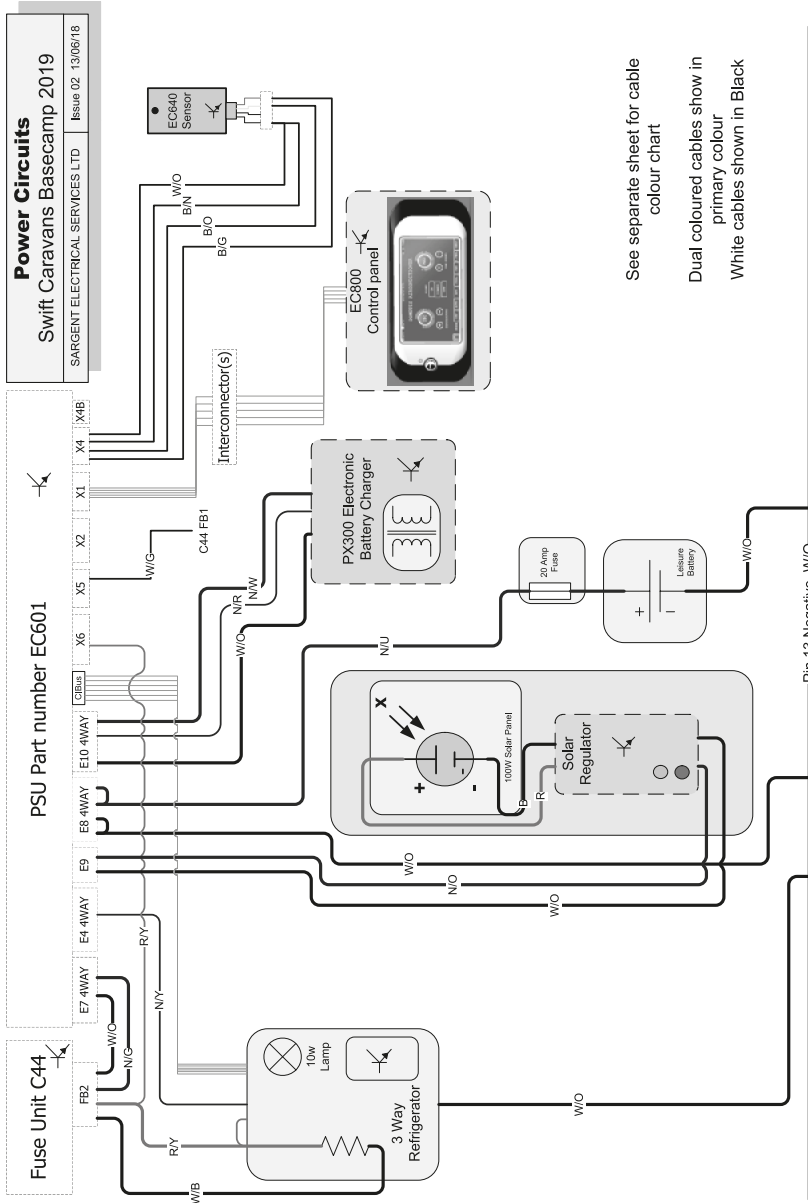

See separate sheet for cable colour chart

Dual coloured cables show in primary colour
White cables shown in Black

Pin 13 Negative W/O

Copyright Sargent Electrical Services Ltd. 2017. All rights reserved. Subject to change without prior notice.

WIRING DIAGRAM - 230V CIRCUITS

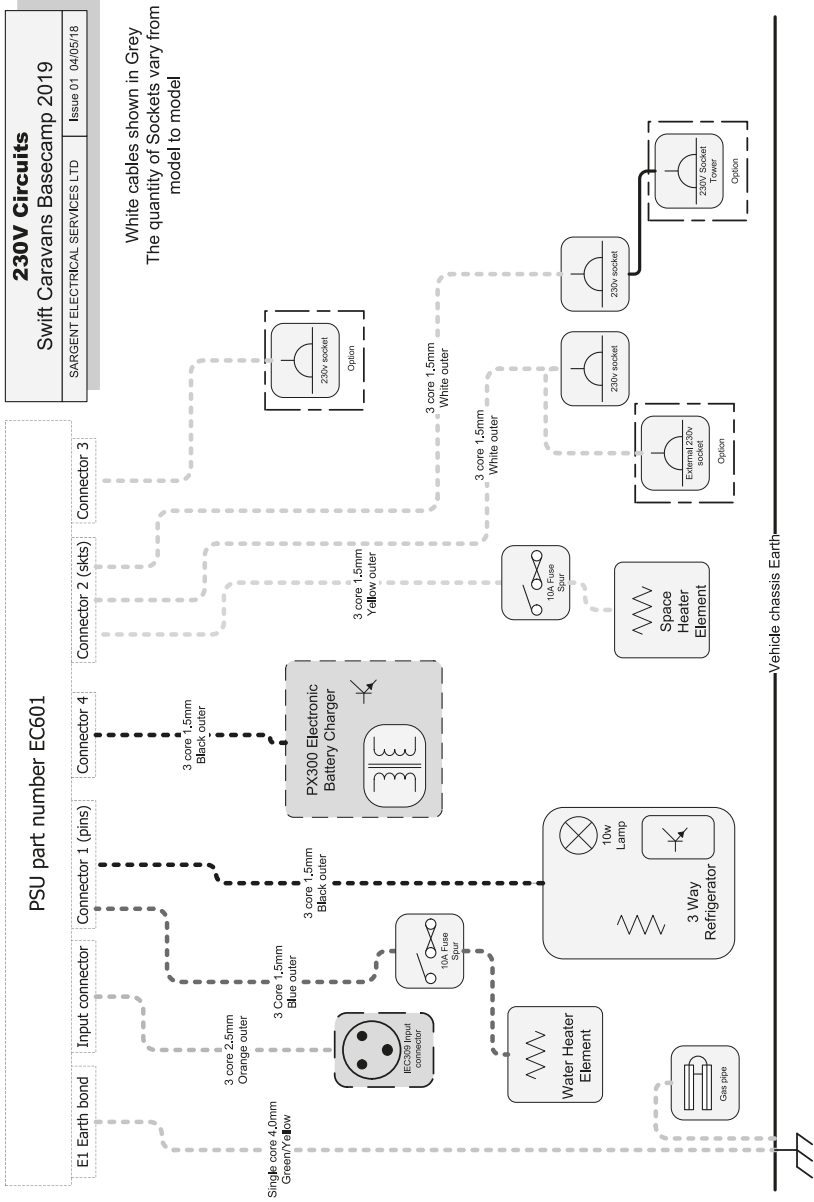

Copyright Sargent Electrical Services Ltd. 2017 all rights reserved. Subject to change without prior notice.

WIRING DIAGRAM - 13 PIN SOCKET

ISO 11446 Circuits

Swift Group Caravans (where applicable)

SARGENT ELECTRICAL SERVICES LTD Issue 01 06/07/10

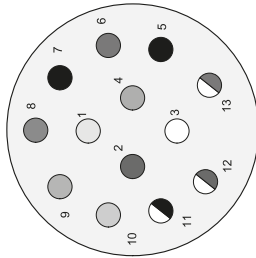

11446 Plug Connector viewed from cable entry on plug

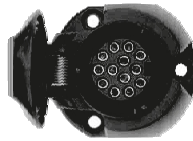

It is possible to get adaptors that convert two sockets on the towbar to a single 13 pin ISO socket, and vice versa.

Connection lead from 12N 7 pin socket plus 12S 7 pin socket to 13pin Euro Socket. (Converts a vehicle with two 7 pin sockets to a caravan with a 13 pin plug)

Please be aware that some car and adaptor manufacturers don't provide the fridge power connections

Pin No	Core Colour	Core Size	Function
1	Yellow	1.5	Left Hand Indicator Light
2	Blue	1.5	Rear Fog Warning Light(s)
3	White	2.5	Earth for pins 1 - 8
4	Green	1.5	Right Hand Indicator Light
5	Brown	1.5	Right Hand Tail Light
6	Red	1.5	Brake Lights
7	Black	1.5	Left Hand Tail Light
8	Pink	1.5	Reverse Light(s)
9	Orange	2.5	Car +ve
10	Slate (Grey)	2.5	Fridge +ve
11	White/Black	2.5	Earth for pin 10
12	White/Blue	1.5	Not Yet Allocated
13	White/Red	2.5	Earth for pin 9

Copyright Sargent Electrical Services Ltd. 2017 All rights reserved. Subject to change without prior notice.

Example



Y/U

Yellow cable with Blue stripe

Cable Colour Chart

Swift range 2019

SARGENT ELECTRICAL SERVICES LTD Issue 04/05/18

WIRING DIAGRAM - CABLE COLOUR CHART

12v Cable Colours

B	BLACK
N	BROWN
R	RED
O	ORANGE
Y	YELLOW
G	GREEN
U	BLUE
P	PURPLE
S	SLATE GREY
W	WHITE
K	PINK

230v Cable Colours

B	BLACK
N	BROWN
W	WHITE
O	ORANGE
Y	YELLOW
G	GREEN
U	BLUE

USEFUL INFORMATION

Owners Club	156
Spares and after sales Supercare	156
Repair facilities	156
Caravan Clubs	157
Motoring Associations	157
Trade Association	157
Change of ownership	158
Index	162

USEFUL INFORMATION

Owners club

The Owners Club is a completely independent organisation run for the benefit of the caravan owners. They have numerous rallies during the year in various parts of the country. Apart from the friendliness and companionship the Club generates it is also actively engaged in charity work for those less fortunate than ourselves.

There are links to the owners club websites from the Swift Group website -

www.swiftgroup.co.uk

Spares and after sales

A catalogue of spare parts are available through our Swift Group Dealer Network, from door catches through to spare wheels. Please note, all parts enquiries must be directed through your dealer, as the Swift Group does not operate a direct retail service.

We endeavour to supply parts for vehicles up to 8 years old. If the original part is no longer available your dealer should be able to source a suitable alternative.

Note: Please remember to quote chassis number when ordering any items from your dealer.

Repair facilities

Should you be unfortunate to encounter damage to your vehicle, we have a number of approved workshops and dealerships with workshop facilities to undertake such repairs.

Details of which can be found via our website:

www.swiftgroup.co.uk/find-a-dealer

The enjoyment of caravanning can be greatly enhanced by membership of one or more of the various caravanning, motoring and holiday clubs. Here are some useful addresses:

Caravan Clubs

The Caravan Club

East Grinstead House,
East Grinstead
West Sussex, RH19 IUA

Tel: 01342 326944
www.caravanclub.co.uk

The Camping and Caravanning Club

Greenfields House,
Westwood Way,
Coventry,
West Midlands.

Tel: 024 7647 5448
www.campingandcaravanningclub.co.uk

Motoring Associations

Automobile Association (AA)

Fanum House,
Basingstoke,
Hants. RG1 2EA

Tel: 08705 448866
www.theaa.co.uk
e-mail: customer.services@theaa.com

RAC Motoring Services

8 Surrey St.
Norwich
Norfolk
NR1 3NG

Tel: 01922 437 000
www.rac.co.uk

Green Flag National Breakdown

Tel: 0845 246 1557
www.greenflag.com

RBS Insurance

Churchill Cover
West Moreland Road
Bromley, Kent
BR1 1DP
0800 051 3030

Trade Association

NCC

Catherine House,
Victoria Road,
Aldershot,
Hampshire, GU11 1SS

Tel: 01252 318251
www.thencc.org.uk
e-mail: info@thencc.org.uk

Change of ownership

Notification of change of ownership

As the new second hand owner, please notify the Swift Group of the change of ownership by completing this page, detaching it and sending it to:

Customer Services Department
Swift Group Limited,
Dunswell Road,
Cottingham,
East Yorkshire,
HU16 4JX.

Note: Warranties are only transferable providing the terms and conditions of the warranty have been met by the previous owner(s). Please see warranty information at the beginning of this handbook for full details. The 'Extended Body shell warranty' is a non-transferable warranty.

CHANGE OF OWNERSHIP

Details of caravan:	Model:	
	Chassis No:	
New owner:	Name:	
	Address:	
	Email:	
	Telephone:	
	Mobile:	
	Date of purchase:	
Previous owner:	Name:	
	Address:	
	Email:	
	Telephone:	
	Mobile:	
	Date of purchase:	

Symbols

13 pin connection.....	59
13 pin socket.....	27
230V mains electrical equipment power consumption.....	60

A

Acrylic windows.....	122
AK161 hitch	35
alarm system	42
AL-KO ATC trailer control system	131
AL-KO braking system adjustment	136
AL-KO chassis	129
AL-KO operating instructions.....	42
AL-KO Secure immobiliser.....	41
AL-KO side lift jack	42
ALKO Spare wheel and carrier tips	32
Appliance consumption figures.....	62
Arrival on site.....	34
Automobile Association (AA).....	157
Awning	117
Awning cleaning and drying	118
Awning fire precautions.....	118
Awning Spaces LPG Appliance Exhaust..	55
Awning ventilation.....	118
Axles trouble shooting & fault finding	143
Axle types.....	135

B

Basecamp technical information.....	146
Basecamp wiring diagrams.....	148
Bathroom / shower.....	125
Battery	90
Bedding.....	115
Bonded roof.....	118
Breakaway cables	29
Bulb Replacement Interior and Exterior lighting.....	147

C

Camping and Caravanning Club.....	157
Caravan clubs	157
Caravan exterior	122
Caravan exterior care.....	122
Caravan handling.....	32
Caravan interior	124
Caravan interior care.....	124
Caravan motor movers	18, 118
Caravan movers	122
Caravan terms.....	14
Caravan towing code.....	14
Change of ownership	159
Changing a gas cylinder	55
Changing a wheel.....	33
Clubs and trade bodies	157
CO alarm.....	38
Colour reference.....	118
Condensation	123
Condensation prevention.....	123
Coupling Heads troubleshooting.....	144
Coupling Up	140
Cylinder compartment	53

D

Dometic absorption refrigerator	100
Doorscreen.....	115
Driving licence	17

E

Electrical Operation of Whale Space Heater...	99
Electrical operation of Whale Water Heater	98
Electrical overseas connection.....	58
Escape paths	38
Exterior 230V Whale Mains Electric Out Socket (when fitted)	93
Exterior door.....	35, 115

Exterior door key	115	Moving off	31
External BBQ Outlet Socket.....	111	N	
External shower point	112	NCC.....	157
F		Nose weight	15
FENIX Work surfaces	120	O	
Fire	38	Oven Temperature Control.....	109
Fire Extinguisher	38	Overrun Device.....	141
Flue installations	56	Owners club	156
Furniture	125	P	
G		Plumbing Connections.....	46
Galvanised parts.....	128	Preparing for the road.....	20
Galvanised steel chassis.....	22	Pre-tow check list.....	25, 26
Gas	53	R	
Gas faults	57	RAC motoring services	157
Gas Hoses	53	RBS Insurance	157
Gas safety advice	54	Regulators	53
Gas schematic	52	Repair facilities.....	156
Generator usage.....	92	Reversing	31
Glossary & checklist	17	Roller blind advice	116
Green Flag National Breakdown	157	Roof	118
H		Rooflight.....	116
Habitation relay.....	93	Roof lights	116
Hitching-Up	24	S	
J		Sanitising water tanks and water system .	48
Jacking points	33	Security	39
L		Selecting a pitch	34
LED road lighting	28	Shower use	117
Levelling the caravan	34	Smoke Alarm operation	38
Loading	134	Snaking	22
M		Solar Energy System	91
Measurement of nose weight.....	16	Spares and after sales customer care....	156
Modifications	122	Speed limits.....	31
Motoring associations.....	157	Stabilisers and coupling devices	139
Motorway driving	32	Stability.....	22

INDEX

- Step on hitch cover 118
- Stopping on a hill 34
- Suitable towing vehicles 22
- Supplier contacts 12
- Swift Command Power Control System... 64
- Swift Command Tracker 40
- Swift Shield Fabric 125
- Swift Talk 2
- T**
- Table storage 117
- The electrical system 58
- Thetford hob 900 Series 101
- Thetford MK3 Mini Grill 108
- Thetford MK3 Oven 108
- Thetford Toilet 111
- Tow car electrics 27, 28
- Towing vehicle's rear suspension 21
- Towing vehicle terms 16
- Trade association 157
- TV Antenna 114
- Types of tyres fitted 23
- Tyre law 24
- Tyre maintenance 23
- U**
- Uncoupling 140
- Unhitching 35
- USB Socket 95
- Useful items 18, 19
- V**
- Ventilation 39
- W**
- Water faults 50
- Water Out Socket with
Whale Compact Shower 112
- Water pump pressure switch adjustment . 48
- Water system 44
- Water system trouble shooting 47
- Whale Space Heater 99
- Whale water heater 98
- Wheel bolt tightening 33
- Windows 116
- Winterisation 126
- Wiring of connecting cable and
caravan mains inlet 61

USEFUL INFORMATION



All Swift Group models have been certified by the National Caravan Council for compliance with stringent European Standards, British Legislation and industry set Codes of Practice specifically relating to health and safety issues.

The approval process covers the testing and inspection of critical areas of the product from fire safety, weights and dimensions, to gas, electrics and ventilation. Every caravan carries the "NCC Approved Caravan" badge.

The NCC also conduct unannounced inspections at the Swift factory to ensure continued compliance. NCC Approval gives you peace of mind that your caravan is legal and safe.

All Swift Group touring caravans are European Whole Vehicle Type Approved.

This is your assurance that these caravans meet all European regulations, and have been constructed and conform to approved standards of safety and manufacturing.

IMPORTANT CUSTOMER NOTICE

TOURING CARAVAN MODEL YEAR

The model year runs from 1st September to 31st August.

For example, the earliest a 2017 model would be registered under the Caravan Registration Identification Scheme (CRiS) is 1st September 2016.



CRiS is the Central Registration & Identification Scheme that issues touring caravan registration documents, equivalent to that of the V5 registration document issues by the DVLA for cars. CRiS was established in 1992 by The National Caravan Council and provides a method of registering the "keeper" details of every tourer manufactured by NCC member companies to help prevent and detect caravan related crime.

Why register with CRiS?

- Safety • Security • Warranty

Did you know..?

You should not take a tourer abroad without a registration document. If you go abroad your CRiS registration certificate provides the necessary proof, required by the police and other authorities, that you are its registered keeper.

If you need to make a claim on your insurance, CRiS can help speed up claims by providing details of your tourer and its purchase date to relevant parties.

CRiS can help your tourer's manufacturer contact you in the event that there is any kind of product recall or fault that could affect the safety of your caravan.

CRiS Registration and VIN Chip Caravan Registration

Your caravan has been security marked and recorded under the Caravan Registration and Identification Scheme that is recognised by the Caravan Industry.

Shortly after purchasing this caravan you should receive your Touring Caravan Registration Document. It will be sent by post to you home address.

Your Touring Caravan Registration Document will include a 17 character VIN (Vehicle Identification Number), shown in the top right hand corner. This 17 character will be permanently marked onto the caravan chassis.

To protect yourself and your touring caravan, never leave the Registration Document in the caravan. For security reasons keep it in a safe place.

If you sell the caravan please follow the instructions on the Touring Caravan Registration Document.

If you do not receive a Touring Caravan Registration Document, lose it, or any of the details recorded are incorrect, please contact: CRiS, Avonbridge House, Bath Road, Chippenham, Wiltshire, SN15 2BB or Tel 0203 282 1000.

VIN Chip Caravan Identification

The caravan's unique 17 character VIN will be incorporated into VIN Chip tamper evident labels; the master VIN Chip label is situated on the front near side window to aid police checking, another in the gas locker and a maximum of 10 placed on the inside of the windows (with the exception of opaque windows).

Three electronic RFID chips containing the individual identity of your caravan are concealed within the caravan and can only be read by using a specially programmed RFID scanner.

Your local police can obtain the use of a CRiS VIN Chip scanner by contacting CRiS on Tel 0203 282 1000.

For help, support and advice Contact CRiS:

NCC CRiS Ltd
PO Box 445
Aldershot
GU11 9SF

Tel 0203 282 1000

www.cris.co.uk

Opening Hours: Monday - Friday 8am to 8pm
Saturday 9am to 5pm
Sunday 10am to 5pm

CREATING SMILES FOR LIFE



SWIFT GROUP

Dunswell Road
Cottingham
East Yorkshire
HU16 4JX

Tel: 01482 875740

Fax: 01482 840082

Email: enquiry@swiftgroup.co.uk

FIND OUT MORE AT SWIFTGROUP.CO.UK



Brochure



Layouts



Dealer



Video



Social