



Swift Group  
Dunswell Road  
Cottingham  
East Yorkshire HU16 4JX  
Tel **01482 847332**  
Fax **01482 841042**  
email [enquiry@swiftgroup.co.uk](mailto:enquiry@swiftgroup.co.uk)

For more information visit  
[www.swiftgroup.co.uk](http://www.swiftgroup.co.uk)

Issued July 2012

# Challenger Sport - Eccles Sport Technical Handbook

---

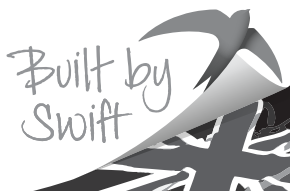

Specifications ..... 2

Wiring Diagrams ..... 4

Bulb Chart ..... 11

Bulb Replacement..... 12

# Specification

<b>Challenger Sport</b>	<b>442</b>	<b>514</b>	<b>524</b>	<b>544</b>
<b>Eccles Sport</b>	<b>442</b>	<b>514</b>	<b>524</b>	<b>544</b>
Berths	2	4	4	4
Axles	1	1	1	1
Internal Length (bed box height)	4.40m/14'5"	5.23m/17'2"	5.29m/17'4"	5.60m/18'4"
Overall Width	2.25m/7'5"	2.25m/7'5"	2.25m/7'5"	2.25m/7'5"
Overall Height (inc. TV Aerial)*	2.64m/8'8"	2.65m/8'8"	2.65m/8'8"	2.65m/8'8"
Maximum Internal Headroom	1.95m/6'5"	1.95m/6'5"	1.95m/6'5"	1.95m/6'5"
Overall Length	6.06m/19'11"	6.88m/22'7"	6.94m/22'9"	7.25m/23'9"
Awning A/A dimension†	8.79m/28'10"	9.62m/31'7"	9.68m/31'9"	9.99m/32'9"
Mass in Running Order (inc. tolerance)	1114kg/21.9cwt	1230kg/24.2cwt	1265kg/24.9cwt	1282kg/25.2cwt
Maximum Technical Permissible Laden Mass (Lower limit)	1235kg/24.3cwt	1380kg/27.2cwt	1415kg/27.9cwt	1435kg/28.2cwt
Maximum Technical Permissible Laden Mass (Upper limit)	1350kg/26.6cwt	1500kg/29.5cwt	1500kg/29.5cwt	1500kg/29.5cwt
Total user Payload	121kg/2.4cwt	150kg/3.0cwt	150kg/3.0cwt	153kg/3.0cwt
Personal Effects	121kg/2.4cwt	150kg/3.0cwt	150kg/3.0cwt	153kg/3.0cwt
Options	0kg/0cwt	0kg/0cwt	0kg/0cwt	0kg/0cwt
Tyre Size	185 R14C 102Q	185 R14C 102Q	185 R14C 102Q	185 R14C 102Q
Tyre pressure at Lower limit MTPLM	3.4 bar / 49 psi	4.0 bar / 58 psi	4.1 bar / 59 psi	4.1 bar / 59 psi
Tyre pressure at Upper limit MTPLM	3.8 bar / 55 psi	4.4 bar / 64 psi	4.4 bar / 64 psi	4.4 bar / 64 psi
Static Load on Coupling Head	100kg	100kg	100kg	100kg
Thermal Insulation Grade	THREE	THREE	THREE	THREE
<b>Bed Sizes</b>				
Front Double	202cm x 180cm 6'8" x 5'11"	202cm x 153cm/ 6'8" x 5'0"	202cm x 180cm/ 6'8" x 5'11"	202cm x 159cm/ 6'8" x 5'3"
or Front Nearside Single	190cm x 72cm/6'3" x 2'4"	153cm x 72cm/5'0" x 2'4"	180cm x 72cm/5'11" x 2'4"	160cm x 72cm/5'3" x 2'4"
and Front Offside Single	180cm x 72cm/5'11" x 2'4"	160cm x 72cm/5'3" x 2'4"	190cm x 72cm/6'3" x 2'4"	160cm x 72cm/5'3" x 2'4"
Rear Double		198cm x 133cm/6'6" x 4'4"		191cm x 133cm/6'3" x 4'4"
Rear Bunk				
Side Single (offside)			180cm x 62cm/5'11" x 2'0"	
Side Single (nearside)				
Side Bunk (offside)			176cm x 59cm/5'9" x 1'11"	
Side Bunk (nearside)				
Rear Fixed Lower Bunk				
Rear Fixed Mid Bunk				
Rear Fixed Upper Bunk				
Side Fixed Lower Bunk				
Side Fixed Mid Bunk				
Side Fixed Upper Bunk				

**Weights:** The method of calculating the Mass in Running Order (MRO) and user payload figures has changed in order to bring it in line with European Vehicle Directives.

Allowances for essential equipment (e.g. gas cylinders) previously allowed for in the user payload are now contained within the MRO. A provision for a leisure battery which used to be within the essential

equipment payload has now been included within the personal effects payload allowance.

Although the method of calculation has changed, the overall effect is that the amount of payload available to the customer has remained the same, it is just calculated in a different manner

**Bed Sizes :** Please note that the front double bed sizes quoted are for seating configurations without chest of drawers. The front double bed width for a layout with a chest of drawers fitted will be reduced by 0.4m(1'4") from that stated.

<b>554</b>	<b>564</b>	<b>584</b>	<b>585</b>	<b>586</b>	<b>636</b>
<b>554</b>	<b>564</b>	<b>584</b>	<b>585</b>	<b>586</b>	<b>636</b>
4	4	4	6	6	6
1	1	1	1	1	2
5.60m/18'4"	5.60m/18'4"	5.83m/19'2"	5.60m/18'4"	5.83m/19'2"	6.27m/20'7"
2.25m/7'5"	2.25m/7'5"	2.25m/7'5"	2.25m/7'5"	2.25m/7'5"	2.25m/7'5"
2.65m/8'8"	2.65m/8'8"	2.65m/8'8"	2.65m/8'8"	2.65m/8'8"	2.62m/8'7"
1.95m/6'5"	1.95m/6'5"	1.95m/6'5"	1.95m/6'5"	1.95m/6'5"	1.95m/6'5"
7.25m/23'9"	7.25m/23'9"	7.48m/24'6"	7.25m/23'9"	7.48m/24'6"	7.93m/26'0"
9.99m/32'9"	9.99m/32'9"	10.22m/33'6"	9.99m/32'9"	10.22m/33'6"	10.66m/35'0"
1277kg/25.1cwt	1290kg/25.4cwt	1308kg/25.7cwt	1312kg/25.8cwt	1381kg/27.2cwt	1470kg/28.9cwt
1430kg/28.1cwt	1443kg/28.4cwt	1464kg/28.8cwt	1485kg/29.2cwt	1557kg/30.6cwt	1650kg/32.5cwt
1500kg/29.5cwt	1500kg/29.5cwt	1500kg/29.5cwt	1500kg/29.5cwt	1600kg/31.5cwt	1800kg/35.4cwt
153kg/3.0cwt	153kg/3.0cwt	156kg/3.1cwt	173kg/3.4cwt	176kg/3.5cwt	180kg/3.5cwt
153kg/3.0cwt	153kg/3.0cwt	156kg/3.1cwt	173kg/3.4cwt	176kg/3.5cwt	180kg/3.5cwt
0kg/0cwt	0kg/0cwt	0kg/0cwt	0kg/0cwt	0kg/0cwt	0kg/0cwt
185 R14C 102Q	185 R14C 102Q	185 R14C 102Q	185 R14C 102Q	195/70 R15C 104R	185/70 R14 88T
4.1 bar / 59 psi	4.2 bar / 61 psi	4.2 bar / 61 psi	4.3 bar / 62 psi	4.3 bar / 62 psi	2.0 bar / 29 psi
4.4 bar / 64 psi	4.4 bar / 64 psi	4.4 bar / 64 psi	4.4 bar / 64 psi	4.4 bar / 64 psi	2.2 bar / 32 psi
100kg	100kg	100kg	100kg	100kg	100kg
THREE	THREE	THREE	THREE	THREE	THREE
<b>Bed Sizes</b>					
202cm x 159cm/ 6'8" x 5'3"	202cm x 159cm/ 6'8" x 5'3"	202cm x 159cm/ 6'8" x 5'3"	202cm x 180cm/ 6'8" x 5'11"	202cm x 180cm/ 6'8" x 5'11"	202cm x 180cm/ 6'8" x 5'11"
160cm x 72cm/5'3" x 2'4"	160cm x 72cm/5'3" x 2'4"	160cm x 72cm/5'3" x 2'4"	180cm x 72cm/5'11" x 2'4"	190cm x 72cm/6'3" x 2'4"	180cm x 72cm/5'11" x 2'4"
160cm x 72cm/5'3" x 2'4"	160cm x 72cm/5'3" x 2'4"	160cm x 72cm/5'3" x 2'4"	180cm x 72cm/5'11" x 2'4"	180cm x 72cm/5'11" x 2'4"	190cm x 72cm/6'3" x 2'4"
191cm x 133cm/6'3" x 4'4"		185cm x 133cm/6'1" x 4'4"			
	192cm x 71cm/6'4" x 2'4"				180cm x 82cm/5'11" x 2'8"
	183cm x 75cm/6'0" x 2'6"		180cm x 62cm/5'11" x 2'0"	180cm x 67cm/5'11" x 2'2"	
					176cm x 59cm/5'9" x 1'11"
			176cm x 59cm/5'9" x 1'11"	176cm x 59cm/5'9" x 1'11"	
			183cm x 57cm/6'0" x 1'10"	183cm x 57cm/6'0" x 1'10"	181cm x 57cm/5'11" x 1'10"
			183cm x 57cm/6'0" x 1'10"	183cm x 57cm/6'0" x 1'10"	181cm x 57cm/5'11" x 1'10"

**Awning sizes:** Due to varying awning designs and sizes the awning sizes given are approximate only. Specific awning sizes must be confirmed by your dealer or awning manufacturer prior to purchase.

\* The dimensions given are approximate due to slight variations in suspension ride heights, loading conditions and tyre pressures. Customers should verify the actual dimensions of their touring caravan before committing to anything that could be impacted by these dimensions

**Please note:** Any dealer fit options will reduce the overall payload available to the user of the caravan. If you require additional payload it is possible to upgrade the MTPLM to the upper limit. Please contact your Swift caravan dealer for more information.

## Challenger Sport - Eccles Sport Road lighting circuits

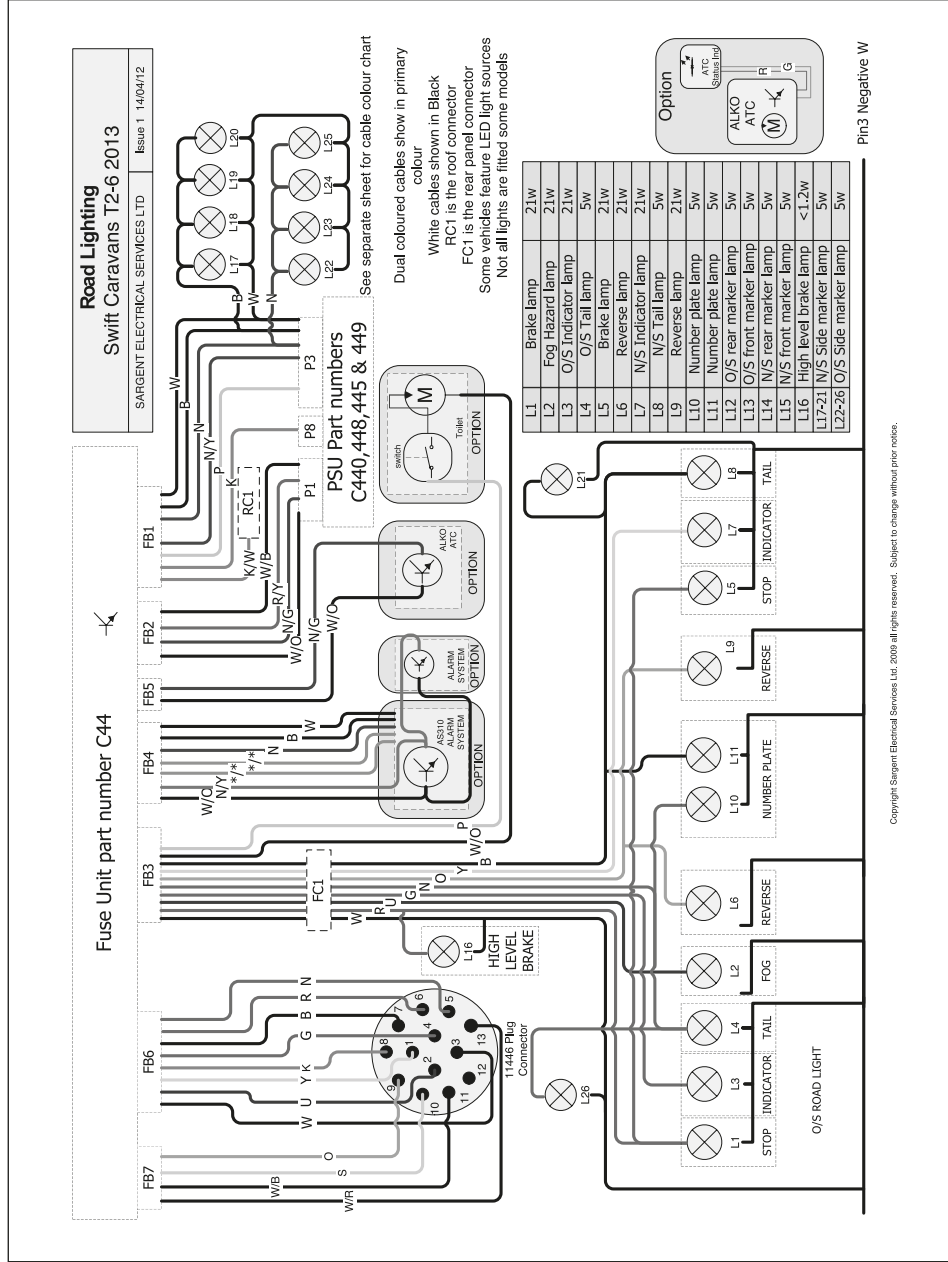

## Challenger Sport - Eccles Sport - Consumer Circuits - Floor circuits

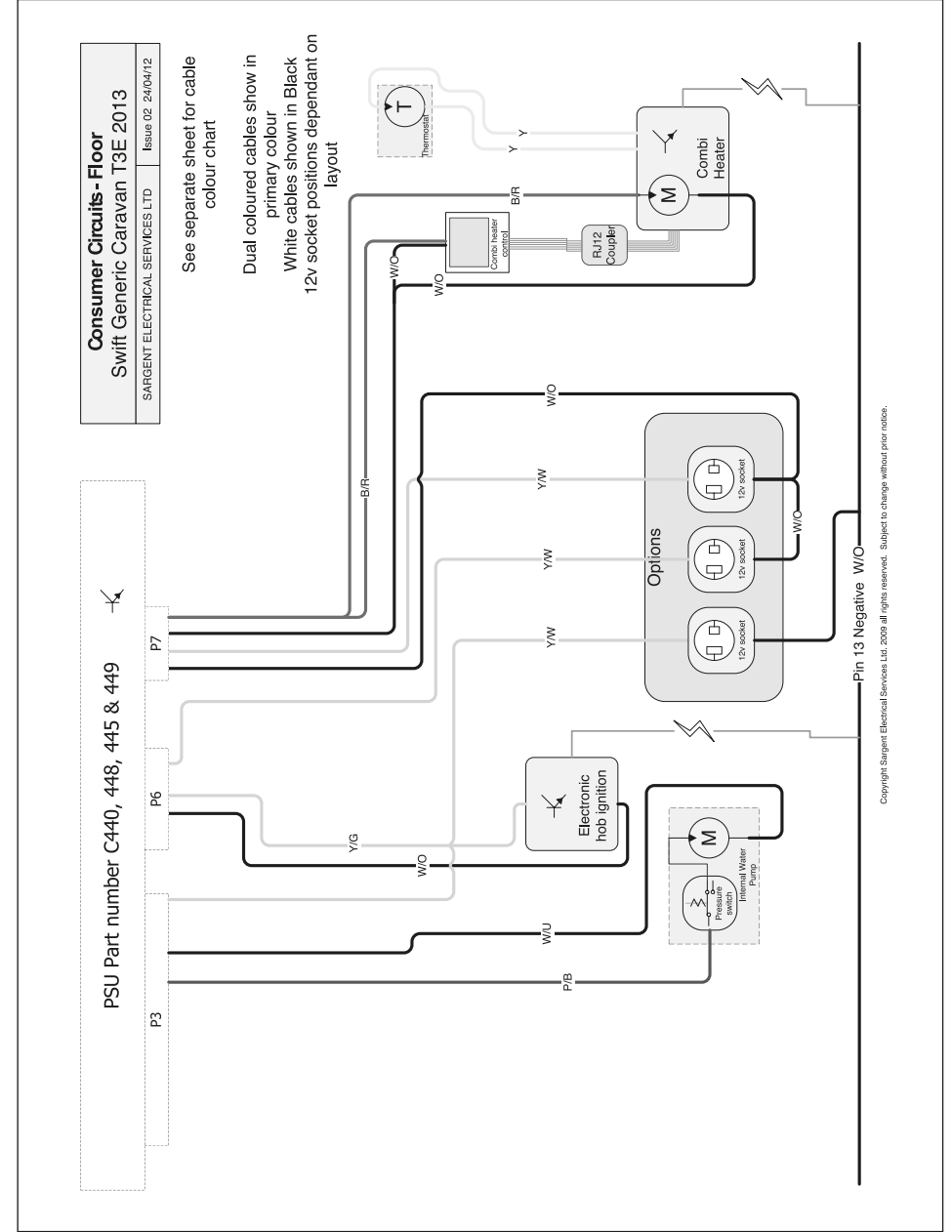

## Challenger Sport - Eccles Sport - Roof lighting circuits

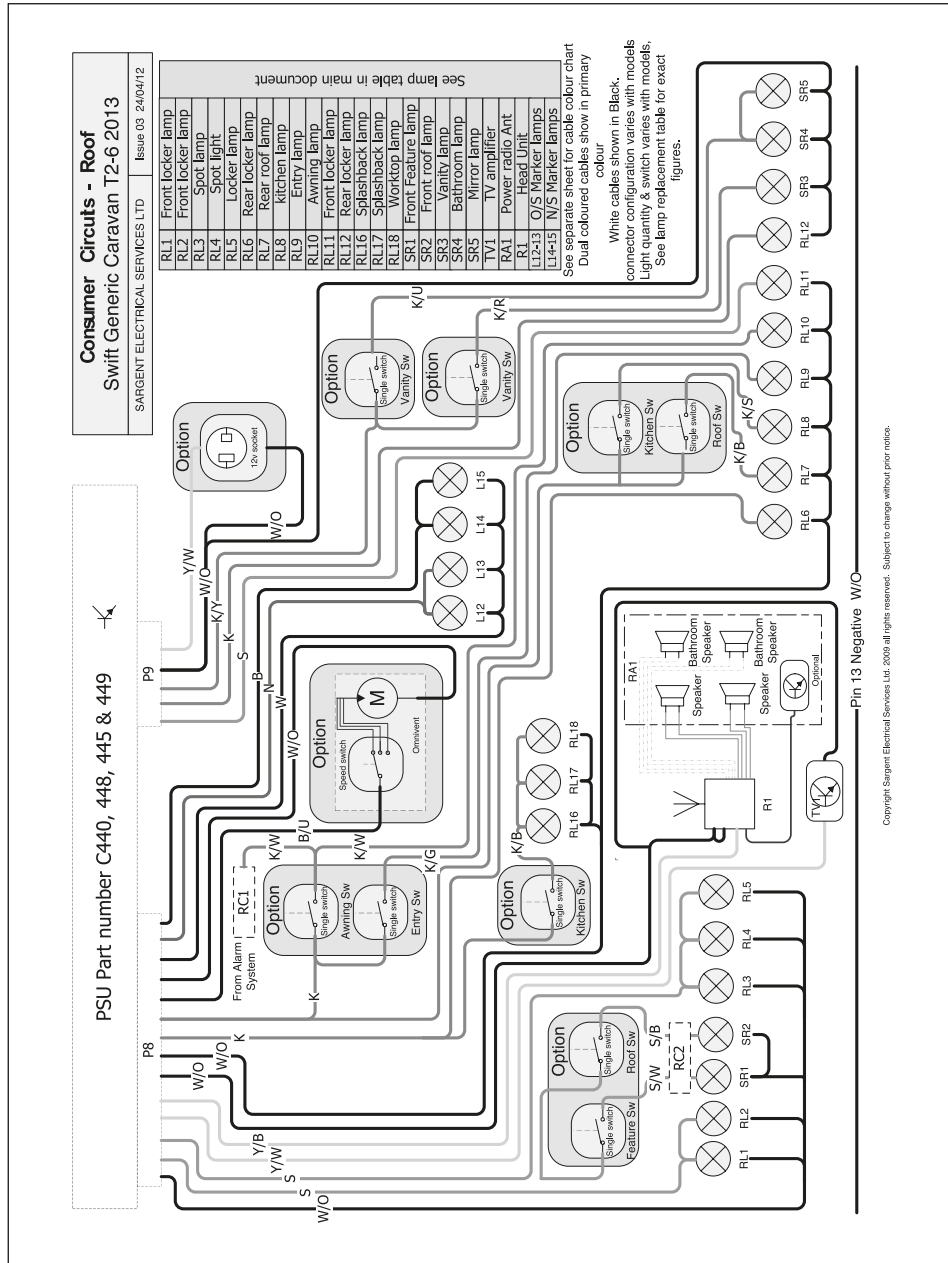

## Challenger Sport - Eccles Sport - Power circuits

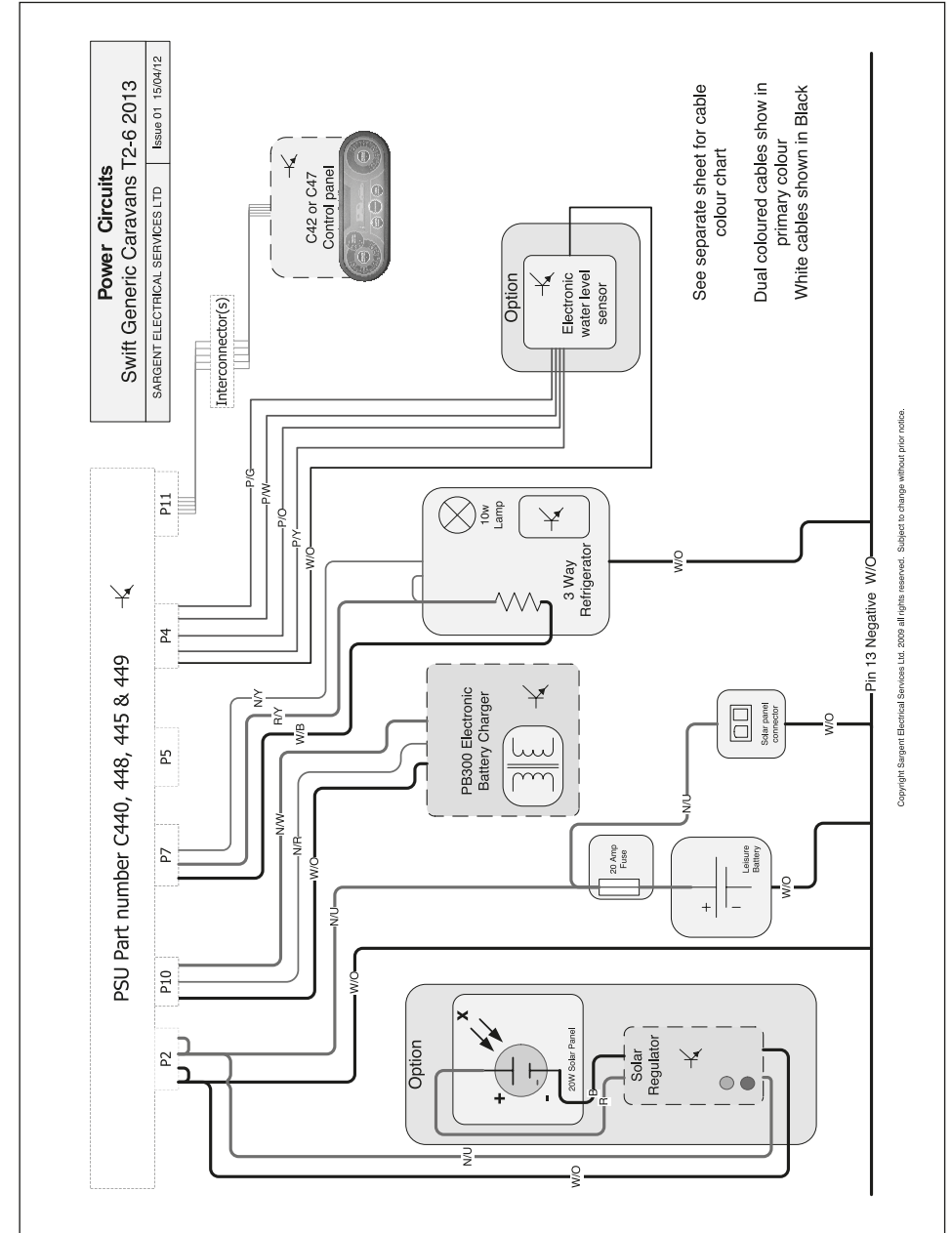

# Wiring Diagrams

## Challenger Sport - Eccles Sport - 230 V

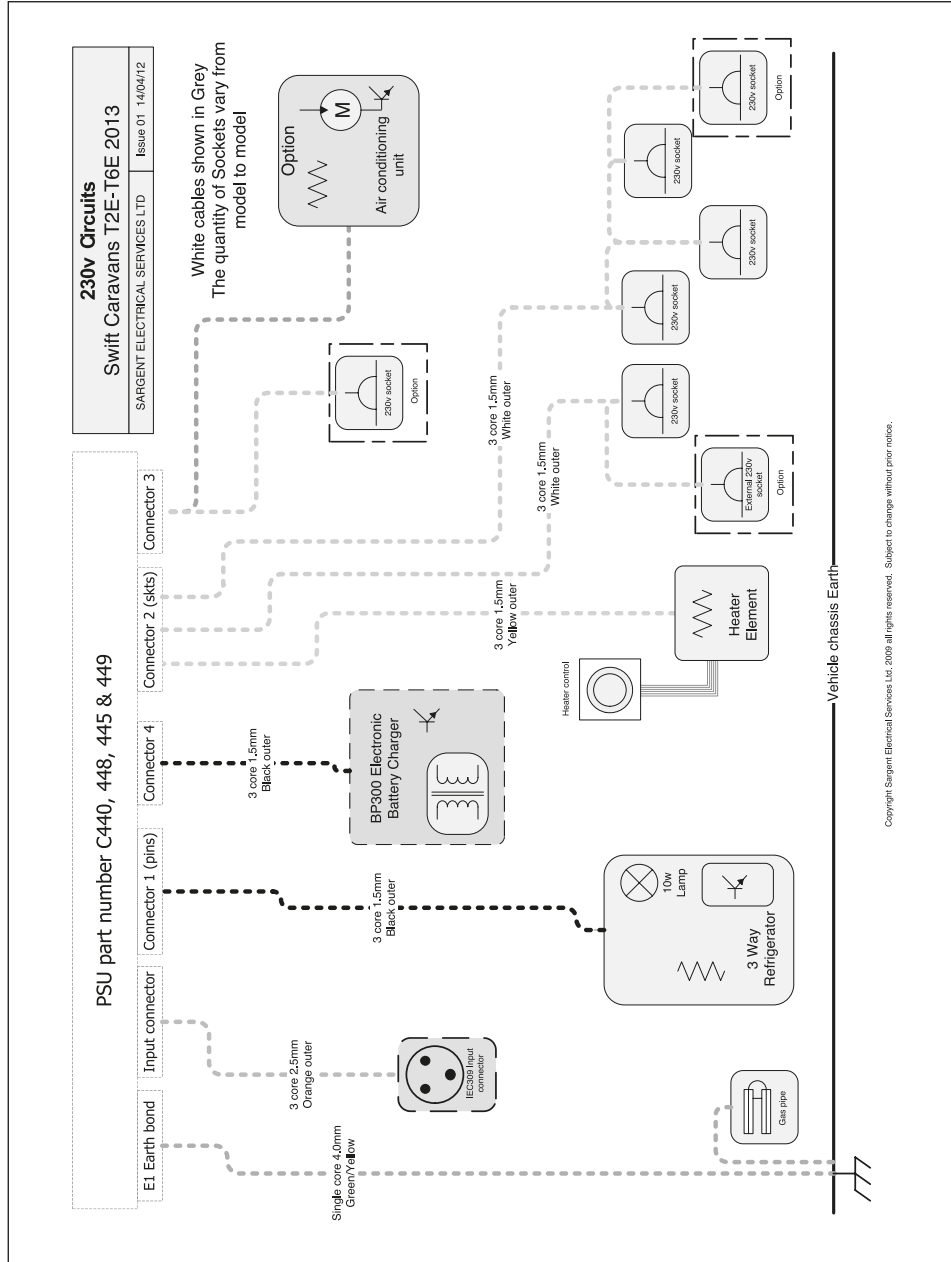

# Wiring Diagrams

## Challenger Sport - Eccles Sport - 13 pin socket

**ISO 11446 Circuits**  
 Swift Group Caravans (where applicable)  
 SARGENT ELECTRICAL SERVICES LTD Issue 01 06/07/10

It is possible to get adaptors that convert two sockets on the towbar to a single 13 pin ISO socket, and vice versa.

Connection lead from 12N 7 pin socket plus 12S 7 pin socket to 13pin Euro Socket. (Converts a vehicle with two 7 pin sockets to a caravan with a 13 pin plug)

Please be aware that some car and adaptor manufacturers don't provide the fridge power connections

11446 Plug Connector viewed from cable entry on plug

Pin No	Core Colour	Core Size	Function
1	Yellow	1.5	Left Hand Indicator Light
2	Blue	1.5	Rear Fog Warning Light(s)
3	White	2.5	Earth for pins 1 - 8
4	Green	1.5	Right Hand Indicator Light
5	Brown	1.5	Right Hand Tail Light
6	Red	1.5	Brake Lights
7	Black	1.5	Left Hand Tail Light
8	Pink	1.5	Reverse Light(s)
9	Orange	2.5	Car +ve
10	Slate (Grey)	2.5	Fridge +ve
11	White/Black	2.5	Earth for pin 10
12	White/Blue	1.5	Not Yet Allocated
13	White/Red	2.5	Earth for pin 9

Copyright Sargent Electrical Services Ltd. 2009 all rights reserved. Subject to change without prior notice.

## Challenger Sport - Eccles Sport - Cable Colour Chart

B	N	R	O	Y	G	U	P	S	W	K
BLACK	BROWN	RED	ORANGE	YELLOW	GREEN	BLUE	PURPLE	SLATE GREY	WHITE	PINK

**12v Cable Colours**



Y/U

Yellow cable with Blue stripe

Example

B	N	W	O	Y	G	U
BLACK	BROWN	WHITE	ORANGE	YELLOW	GREEN	BLUE

**230v Cable Colours**

Cable Colour Chart

Swift range 2011

SARGENT ELECTRICAL SERVICES LTD      Issue 06/07/10

Copyright Sargent Electrical Services Ltd. 2009 all rights reserved. Subject to change without prior notice.

Exterior Lights	Bulb type	Bulb rating
Front marker lights	W5W	12v 5W
Side marker - Low Level	W5W	12v 5W
Side marker - High Level	R5W	12v 5W
Reversing light	P21	12v 21W
Rear indicator light	P21	12v 21W
Brake / tail light	P21/5W	12v 21W/5W
Fog light	P21	12v 21W
Number plate light	C5W	12v 5W
High level brake light	T5/13.5	12v 2.3w
Interior / Other Lights	Bulb type	Bulb rating
Awning lights	FEM0945 complete unit	12v 20W
Ceiling light, triple LED (Kitchen area)	FEM0858 complete lamp	12v LED
Ceiling light, halogen (Bathroom area)	Halogen capsule bulb	12v 10W
Ceiling light, halogen (White, shower area)	Halogen capsule bulb	12v 10W
Locker spotlights, LED	FEM0854 complete lamp	12v LED
Downlighters, LED	FEM0855 (Silver), FEM0856 (Nickel) complete lamp	12v LED
Downlighter, Halogen	Halogen capsule bulb	12v 10W G4
Eyelite Bunk light	T10 (t3/4) wedge	12v 5W
Kitchen light	F25577 complete lamp, flush mount	12v CCFL
Over locker lighting	Fluorescent 300mm	12v 8W
Over locker lighting	Fluorescent 525mm	12v 13W
Feature light over front seating	FEM0937 complete lamp	12v LED

Note: Not all bulbs and lights feature on all models within a range

## Bulb replacement

### CHALLENGER SPORT/ ECCLES SPORT ROAD LIGHT BULB ACCESS

#### STOP / TAIL / INDICATOR AND REVERSE LAMPS

- Bulb access is from front / via lense of each lamp
- Remove 2x screws from each light lense and withdraw lense
- Bulbs are a bayonet fitting – apply slight pressure on bulb towards light fitting, and twist to release
- Reverse procedure to re-fit bulb and lense.
- Take care when replacing stop/tail lamp bulb, that orientation of bulb is correct – to check, brake light operation should be brighter than tail lamp operation.

#### REAR CENTRAL FOG LIGHT

- Bulb access is from front / via lense of lamp
- Remove 2x screws from light lense and withdraw lense
- Bulb is a bayonet fitting – apply slight pressure on bulb towards light fitting, and twist to release
- Reverse procedure to re-fit bulb and lense.

#### UPPER REAR SIDE POSITION LAMPS (RED / CLEAR LENSE)

- Lense is removed from base to access bulb
- Carefully insert small flat bladed screwdriver into recess in lower edge of lamp base. Apply pressure to release locking barb.
- Lift lense upwards and away from lamp base, lower edge first
- Lever bulb out of retaining clips
- Reverse procedure to re-fit bulb and lense

### HIGH LEVEL BRAKE LAMP

- Remove 2x screw cover caps from front face of lamp using small flat bladed screwdriver.
- Remove screws at either end of lamp, and withdraw whole fitting away from rear panel of caravan
- Disconnect lamp from harness
- Re-connect new lamp to harness, and secure lamp to caravan body with 2x screws
- Lamp retaining screws are fixed into a rubber sleeve with a threaded insert, often known as a rawlnut. If lamp has been removed / re-fitted several times the rubber sleeve may need replacing, these are available through your dealer

### NUMBER PLATE LAMPS

- Bulb access is from the front / via lense of each lamp
- Remove the two screws in the lense of the lamp
- Lever the bulb out of retaining clips
- Reverse the procedure to re-fit a new bulb and the light lense

### FRONT MARKER POSITION LAMPS

- Bulb access is from rear of lamp
- Remove 2x screws from light fitting, and withdraw whole fitting from caravan front panel
- Harness plugs into bulb holder – Twist bulb holder relative to lamp body to release bulb holder from lamp body
- Bulbs are push fit into bulb holder – pull bulb directly away from holder to release
- Reverse procedure to replace bulb in holder, holder in lamp and lamp onto caravan body.

### SIDE MARKER POSITION LAMPS

- Bulb access is from rear of lamp. First check from within caravan if the rear of the lamp is accessible:
- If rear of light is accessible:
- Harness plugs into bulb holder – Twist bulb holder relative to lamp body to release bulb holder from lamp body
- Bulbs are push fit into bulb holder – pull bulb directly away from holder to release
- Reverse procedure to replace bulb in holder and holder in lamp
- If rear of light is not accessible:
- Remove 2x screws from light fitting, and withdraw whole fitting from caravan body
- Harness plugs into bulb holder – Twist bulb holder relative to lamp body to release bulb holder from lamp body
- Bulbs are push fit into bulb holder – pull bulb directly away from holder to release
- Reverse procedure to replace bulb in holder, holder in lamp and lamp onto caravan body