



SWIFT GROUP

Dunswell Road
Cottingham
East Yorkshire HU16 4JX
Tel **01482 875740**
Fax **01482 840082**
email enquiry@swiftgroup.co.uk

For more information visit
www.swiftgroup.co.uk

Issued May 2016

CONQUEROR AND ELITE, ELEGANCE AND CONTINENTAL

TECHNICAL HANDBOOK

FIND OUT MORE SWIFTGROUP.CO.UK

 BROCHURE
DOWNLOADS  FIND A
DEALER  FACEBOOK AND
SWIFT-TALK.CO.UK  PRODUCT VIDEOS
SWIFTTV.CO.UK

Swift reserves the right to alter specifications and prices at any time as materials and conditions demand. Please check the website for the latest updates.

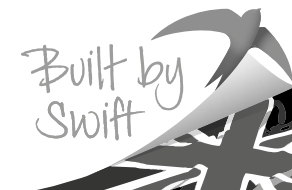

Conqueror Specifications 2

Elite Specifications 2

Elegance Specifications 4

Continental Specifications 4

Wiring Diagrams 6

Conqueror - Elite - Elegance - Continental Bulb Chart..... 14

Conqueror - Elite - Elegance - Continental Bulb Replacement 16

Specification

Conqueror	Conqueror 480	Conqueror 530	Conqueror 560	Conqueror 565
Elite	Elite 480	Elite 530	Elite 560	Elite 565
Berths	2	4	4	4
Axles	1	1	1	1
Internal Length (bed box height)	4.98m/16'4"	5.45m/17'11"	5.93m/19'5"	5.93m/19'5"
Overall Width**	2.26m/7'5"	2.26m/7'5"	2.26m/7'5"	2.26m/7'5"
Overall Height (inc. TV Aerial)**	2.61m/8'7"	2.61m/8'7"	2.61m/8'7"	2.61m/8'7"
Maximum Internal Headroom	1.95m/6'5"	1.95m/6'5"	1.95m/6'5"	1.95m/6'5"
Overall Length**	6.54m/21'5"	7.01m/23'0"	7.49m/24'7"	7.49m/24'7"
Awning A/A dimension	9.01m/29'7"	9.54m/31'4"	10.02m/32'10"	10.02m/32'10"
Mass in Running Order (inc. tolerance)	1328kg/26.1cwt	1434kg/28.2cwt	1515kg/29.8cwt	1508kg/29.7cwt
Maximum Technical Permissible Laden Mass (Lower limit)	1454kg/28.6cwt	1585kg/31.2cwt	1671kg/32.9cwt	1664kg/32.8cwt
Maximum Technical Permissible Laden Mass (Upper limit)	1550kg/30.5cwt	1700kg/33.5cwt	1700kg/33.5cwt	1700kg/33.5cwt
Total user Payload	126kg/2.5cwt	151kg/3.0cwt	156kg/3.1cwt	156kg/3.1cwt
Personal Effects	126kg/2.5cwt	151kg/3.0cwt	156kg/3.1cwt	156kg/3.1cwt
Options	0.0kg/0.0cwt	0.0kg/0.0cwt	0.0kg/0.0cwt	0.0kg/0.0cwt
Tyre Size	185 R14C 102 Q	195/70 R15C 104 R	195/70 R15C 104 R	195/70 R15C 104 R
Tyre pressure at Lower limit MTPLM	61 psi / 4.2bar	64 psi / 4.4bar	65 psi / 4.5bar	65 psi / 4.5bar
Tyre pressure at Upper limit MTPLM	65 psi / 4.5bar	65 psi / 4.5bar	65 psi / 4.5bar	65 psi / 4.5bar
Static Load on Coupling Head	100kg	100kg	100kg	100kg
Thermal Insulation Grade	THREE	THREE	THREE	THREE
Bed Sizes				
Front Double	198cm x 178cm/6'6" x 5'10"	198cm x 178cm/6'6" x 5'10"	198cm x 163cm/6'6" x 5'0"	198cm x 163cm/6'6" x 5'4"
or Front Nearside Single	188cm x 67cm/6'2" x 2'2"	178cm x 67cm/5'10" x 2'2"	153cm x 67cm/5'0" x 2'2"	163cm x 67cm/5'4" x 2'2"
and Front Offside Single	178cm x 67cm/5'10" x 2'4"	188cm x 67cm/6'2" x 2'2"	163cm x 67cm/5'4" x 2'2"	163cm x 67cm/5'4" x 2'2"
Rear Double			182cm x 133cm/6'0" x 4'4"	
Side Single (offside)		180cm x 69cm/5'11" x 2'3"		172cm x 70cm/5'8" x 2'4"
Side Single (nearside)				190cm x 71cm/6'3" x 2'4"
Side Bunk (offside)		176cm x 59cm/5'9" x 1'11"		
Side Bunk (nearside)				
Side Fixed Lower Bunk				
Side Fixed Mid Bunk				
Side Fixed Upper Bunk				

Masses: The masses are calculated in accordance to EU regulation 1230/2012 and NCC code of practice 304.

The Mass in Running Order (MRO) comprises:

1. The mass of the empty caravan as supplied by Swift including loose items such as the hook-up cable, kit bag, entrance step, manuals etc.
2. 10kg allowance for LPG

The MRO is calculated with the fresh water tank, toilet flush tank and water heater empty. If you travel with water in the fresh water tank, toilet flush tank and water heater the payload will be reduced accordingly.

The personal effects is based on the number of berths and the length of the caravan and includes an allowance of 20kg for a leisure battery.

The Maximum Technical Laden Mass (MTPLM) is the maximum mass allowed when the caravan is fully laden.

WARNING: Under no circumstances should the MTPLM be exceeded

Conqueror 570	Conqueror 580	Conqueror 630	Conqueror 645	Conqueror 650
Elite 570	Elite 580	Elite 630	Elite 645	Elite 650
4	4	6	4	4
1	1	2	2	2
5.93m/19'5"	5.93m/19'5"	6.38m/20'11"	6.38m/20'11"	6.38m/20'11"
2.26m/7'5"	2.26m/7'5"	2.26m/7'5"	2.26m/7'5"	2.26m/7'5"
2.61m/8'7"	2.61m/8'7"	2.61m/8'7"	2.61m/8'7"	2.61m/8'7"
1.95m/6'5"	1.95m/6'5"	1.95m/6'5"	1.95m/6'5"	1.95m/6'5"
7.49m/24'7"	7.49m/24'7"	7.94m/26'11"	7.94m/26'11"	7.94m/26'11"
10.02m/32'10"	10.02m/32'10"	10.41m/34'2"	10.41m/34'2"	10.41m/34'2"
1482kg/29.2cwt	1494kg/29.4cwt	1618kg/31.9cwt	1615kg/31.8cwt	1640kg/32.3cwt
1638kg/32.2cwt	1650kg/32.5cwt	1798kg/35.4cwt	1775kg/34.9cwt	1800kg/35.4cwt
1700kg/33.5cwt	1700kg/33.5cwt	1900kg/37.4cwt	1900kg/37.4cwt	1900kg/37.4cwt
156kg/3.1cwt	156kg/3.1cwt	180kg/3.5cwt	160kg/3.1cwt	160kg/3.1cwt
156kg/3.1cwt	156kg/3.1cwt	180kg/3.5cwt	160kg/3.1cwt	160kg/3.1cwt
0.0kg/0.0cwt	0.0kg/0.0cwt	0.0kg/0.0cwt	0.0kg/0.0cwt	0.0kg/0.0cwt
195/70 R15C 104 R	195/70 R15C 104 R	185/70 R14 88 T	185/70 R14 88 T	185/70 R14 88 T
65 psi / 4.5bar	65 psi / 4.5bar	32 psi / 2.2bar	32 psi / 2.2bar	32 psi/2.2bar
65 psi / 4.5bar	65 psi / 4.5bar	33 psi / 2.3bar	33 psi / 2.3bar	33 psi / 2.3bar
100kg	100kg	100kg	100kg	100kg
THREE	THREE	THREE	THREE	THREE
198cm x 163cm/6'6" x 5'4"	198cm x 163cm/6'6" x 5'4"	205cm x 137cm/6'9" x 4'6"	198cm x 163cm/6'6" x 5'4"	198cm x 153cm/6'6" x 5'0"
163cm x 67cm/5'4" x 2'2"	163cm x 67cm/5'4" x 2'2"		163cm x 67cm/5'4" x 2'2"	153cm x 67cm/5'0" x 2'2"
163cm x 67cm/5'4" x 2'2"	163cm x 67cm/5'4" x 2'2"		163cm x 67cm/5'4" x 2'2"	188cm x 67cm/6'2" x 2'2"
191cm x 129cm/6'3" x 4'3"	182cm x 133cm/6'0" x 4'4"	192cm x 129cm/6'4" x 4'3"	182cm x 133cm/6'0" x 4'4"	182cm x 133cm/6'0" x 4'4"
		180cm x 69cm/5'11" x 2'3"		
		176cm x 59cm/5'9" x 1'11"		

Bed Sizes: Please note that the front double bed sizes quoted are for seating configurations without chest of drawers. The front double bed width for a layout with a chest of drawers fitted will be reduced by 0.4m(1'4") from that stated.

Awning sizes: Due to varying awning designs and sizes the awning sizes given are approximate only. Specific awning sizes must be confirmed by your dealer or awning manufacturer prior to purchase.

*Estimated weight

** The dimensions given are approximate due to slight variations in suspension ride heights, loading conditions and tyre pressures.

Customers should verify the actual dimensions of their touring caravan before committing to anything that could be impacted by these dimensions

Please note: Any dealer fit options will reduce the overall payload available to the user of the caravan. If you require additional payload it is possible to upgrade the MTPLM to the upper limit. Please contact your caravan dealer for more information.

Specification

Elegance	Elegance 480	Elegance 530	Elegance 565
Continental	Continental 480	Continental 530	Continental 565
Berths	2	4	4
Axles	1	1	1
Internal Length (bed box height)	4.63m/15'2"	5.45m/17'11"	5.93m/19'5"
Overall Width*	2.26m/7'5"	2.26m/7'5"	2.26m/7'5"
Overall Height (inc. TV Aerial)*	2.61m/8'7"	2.61m/8'7"	2.61m/8'7"
Maximum Internal Headroom	1.95m/6'5"	1.95m/6'5"	1.95m/6'5"
Overall Length*	6.19m/20'4"	7.01m/23'0"	7.49m/24'7"
Awning A/A dimension	8.66m/28'5"	9.54m/31'4"	10.02m/32'10"
Mass in Running Order (inc. tolerance)	1354kg/26.7cwt	1522kg/30.0wt	1570kg/30.9cwt
Maximum Technical Permissible Laden Mass (Lower limit)	1477kg/29.1cwt	1673kg/32.9cwt	1726kg/34.0cwt
Maximum Technical Permissible Laden Mass (Upper limit)	1500kg/29.5cwt	1750kg/34.4cwt	1750kg/34.4cwt
Total user Payload	123kg/2.4cwt	151kg/3.0cwt	156kg/3.1cwt
Personal Effects	123kg/2.4cwt	151kg/3.0cwt	156kg/3.1cwt
Options	0.0kg/0.0cwt	0.0kg/0.0cwt	0.0kg/0.0cwt
Tyre Size	195/70 R15C 104 R	195/70 R15C 104 R	195/70 R15C 104 R
Tyre pressure at Lower limit MTPLM	58 psi / 4.0bar	65 psi/4.5bar	65 psi/4.5bar
Tyre pressure at Upper limit MTPLM	59 psi / 4.1bar	65 psi/4.5bar	65 psi/4.5bar
Static Load on Coupling Head	100kg	100kg	100kg
Thermal Insulation Grade	THREE	THREE	THREE
Bed Sizes			
Front Double	198cm x 178cm/6'6" x 5'10"	198cm x 178cm/6'6" x 5'10"	198cm x 163cm/6'6" x 5'4"
or Front Nearside Single	188cm x 67cm/6'2" x 2'2"	178cm x 67cm/5'10" x 2'2"	163cm x 67cm/5'4" x 2'2"
and Front Offside Single	178cm x 67cm/5'10" x 2'4"	188cm x 67cm/6'2" x 2'2"	163cm x 67cm/5'4" x 2'2"
Rear Double			
Rear Bunk			
Side Single (offside)		180cm x 69cm/5'11" x 2'3"	172cm x 71cm/5'8" x 2'4"
Side Single (nearside)			184cm x 71cm/6'0" x 2'4"
Side Bunk (offside)		176cm x 59cm/5'9" x 1'11"	

Masses: The masses are calculated in accordance to EU regulation 1230/2012 and NCC code of practice 304.

The Mass in Running Order (MRO) comprises:

1. The mass of the empty caravan as supplied by Swift including loose items such as the hook-up cable, kit bag, entrance step, manuals etc.
2. 10kg allowance for LPG

The MRO is calculated with the fresh water tank, toilet flush tank and water heater empty. If you travel with water in the fresh water tank, toilet flush tank and water heater the payload will be reduced accordingly.

The personal effects is based on the number of berths and the length of the caravan and includes an allowance of 20kg for a leisure battery.

The Maximum Technical Laden Mass (MTPLM) is the maximum mass allowed when the caravan is fully laden.

WARNING: Under no circumstances should the MTPLM be exceeded

Elegance 570	Elegance 580	Elegance 630	Elegance 645
Continental 570	Continental 580	Continental 630	Continental 645
4	4	4	4
1	1	2	2
5.93m/19'5"	5.93m/19'5"	6.38m/20'11"	6.38m/20'11"
2.26m/7'5"	2.26m/7'5"	2.26m/7'5"	2.26m/7'5"
2.61m/8'7"	2.61m/8'7"	2.61m/8'7"	2.61m/8'7"
1.95m/6'5"	1.95m/6'5"	1.95m/6'5"	1.95m/6'5"
7.49m/24'7"	7.49m/24'7"	7.94m/26'1"	7.94m/26'1"
10.02m/32'10"	10.02m/32'10"	10.41m/34'2"	10.41m/34'2"
1561kg/30.7cwt	1550kg/30.5cwt	1707kg/33.6cwt	1700kg/33.5cwt
1717kg/33.8cwt	1706kg/33.6cwt	1900kg/37.4cwt	1900kg/37.4cwt
1750kg/34.4cwt	1750kg/34.4cwt	1900kg/37.4cwt	1900kg/37.4cwt
156kg/3.1cwt	156kg/3.1cwt	193kg/3.8cwt	200kg/3.9cwt
156kg/3.1cwt	156kg/3.1cwt	160kg/3.1cwt	160kg/3.1cwt
0.0kg/0.0cwt	0.0kg/0.0cwt	0.0kg/0.0cwt	0.0kg/0.0cwt
195/70 R15C 104 R	195/70 R15C 104 R	185/60 R15 88 H	185/60 R15 88 H
65 psi/4.5bar	65 psi/4.5bar	39 psi/2.7bar	39 psi/2.7bar
65 psi/4.5bar	65 psi/4.5bar	39 psi/2.7bar	39 psi/2.7bar
100kg	100kg	100kg	100kg
THREE	THREE	THREE	THREE
198cm x 163cm/6'6" x 5'4"	198cm x 163cm/6'6" x 5'4"	198cm x 163cm/6'6" x 5'4"	198cm x 163cm/6'6" x 5'4"
163cm x 67cm/5'4" x 2'2"	163cm x 67cm/5'4" x 2'2"	163cm x 67cm/5'4" x 2'2"	163cm x 67cm/5'4" x 2'2"
163cm x 67cm/5'4" x 2'2"	163cm x 67cm/5'4" x 2'2"	190cm x 67cm/6'3" x 2'2"	163cm x 67cm/5'4" x 2'2"
191cm x 129cm/6'3" x 4'3"	182cm x 133cm/6'0" x 4'4"	191cm x 129cm/6'3" x 4'3"	182cm x 133cm/6'0" x 4'4"

Bed Sizes: Please note that the front double bed sizes quoted are for seating configurations without chest of drawers. The front double bed width for a layout with a chest of drawers fitted will be reduced by 0.4m(1'4") from that stated.

Awning sizes: Due to varying awning designs and sizes the awning sizes given are approximate only. Specific awning sizes must be confirmed by your dealer or awning manufacturer prior to purchase.

*Estimated weight

** The dimensions given are approximate due to slight variations in suspension ride heights, loading conditions and tyre pressures.

Customers should verify the actual dimensions of their touring caravan before committing to anything that could be impacted by these dimensions

Please note: Any dealer fit options will reduce the overall payload available to the user of the caravan. If you require additional payload it is possible to upgrade the MTPLM to the upper limit. Please contact your caravan dealer for more information.

Conqueror - Elite - Elegance - Continental Consumer circuits roof

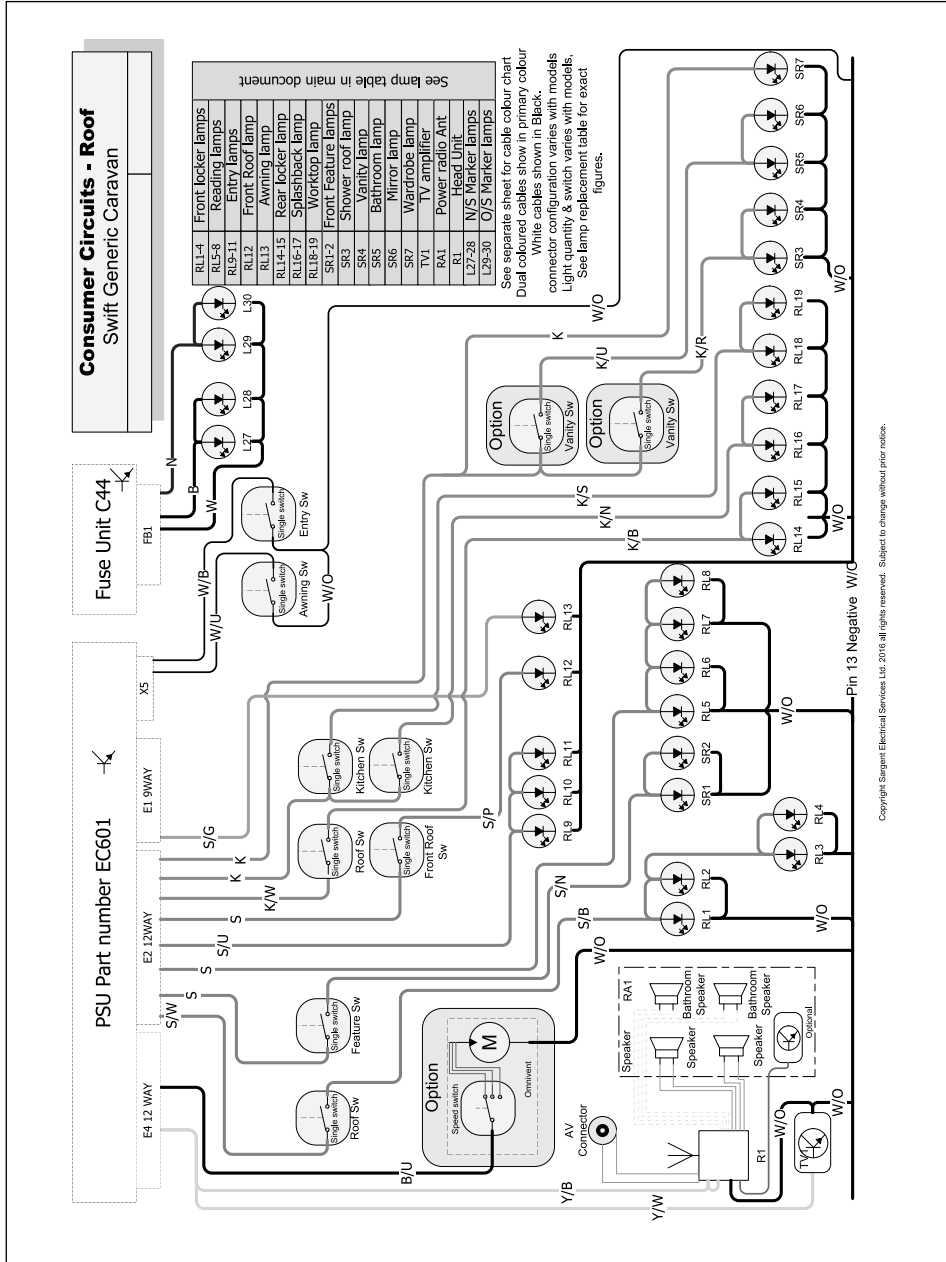

Conqueror - Elite - Elegance - Continental Power circuits

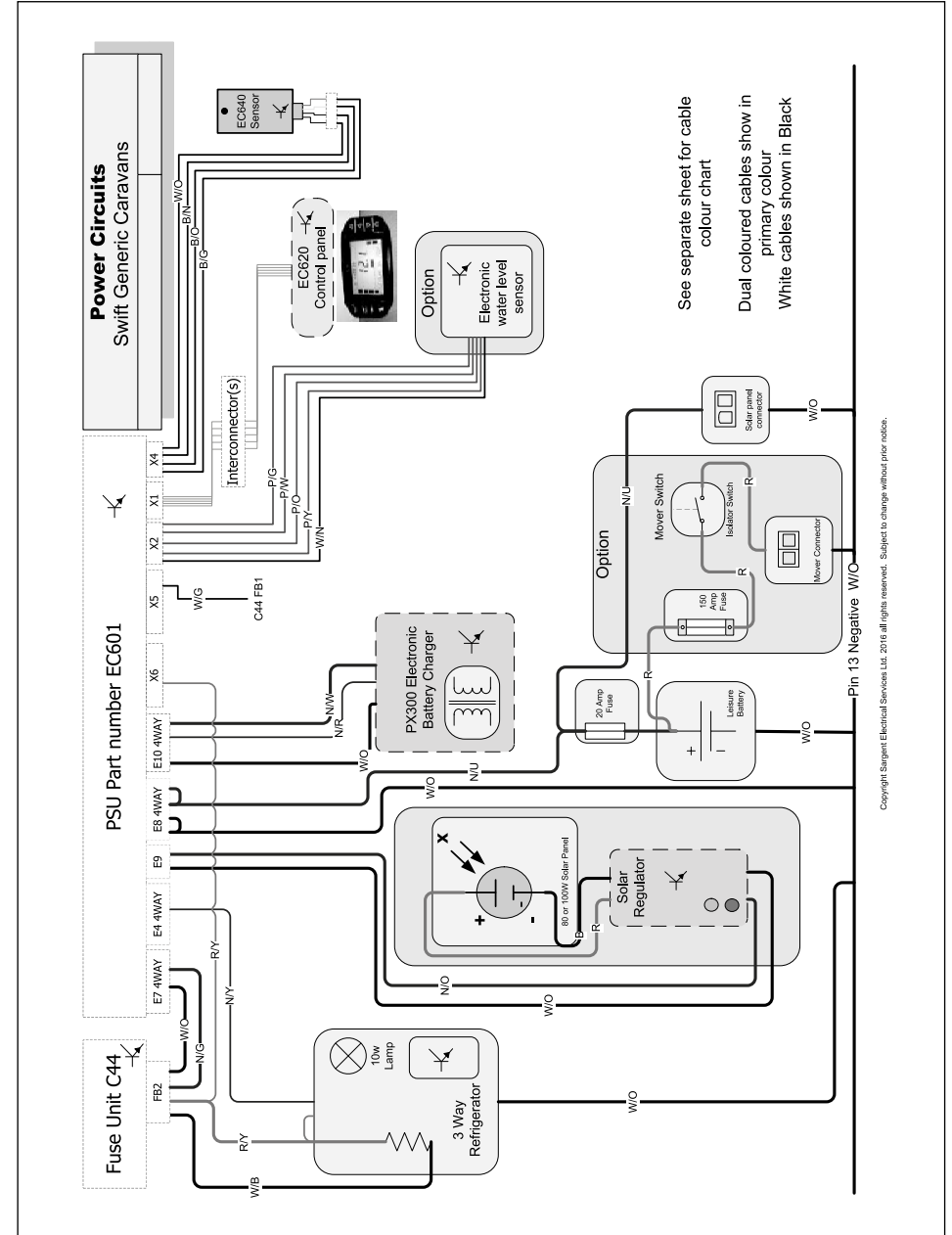

Cable colour chart

Example



Y/U

Yellow cable with Blue stripe

Cable Colour Chart

Swift range

12v Cable Colours

B	BLACK
N	BROWN
R	RED
O	ORANGE
Y	YELLOW
G	GREEN
U	BLUE
P	PURPLE
S	SLATE GREY
W	WHITE
K	PINK

230v Cable Colours

B	BLACK
N	BROWN
W	WHITE
O	ORANGE
Y	YELLOW
G	GREEN
U	BLUE

Copyright Sargent Electrical Services Ltd. 2016. All rights reserved. Subject to change without prior notice.

Bulb Chart

Conqueror - Elite - Elegance - Continental

Exterior Lights	Bulb type	Bulb rating
Front marker lights	LED complete unit L99.00.12V	12v LED
Side marker - Low Level	LED complete unit L99.01.12V	12v LED
Side marker - High Level	R5W	12v 5W
Rear light cluster (Multi - function)	Britax L79.00.12v (LH) & L79.01.12v (RH)	12v LED
Number plate light	C5W	12v 5W
High level brake light	LED Complete unit 15.0024.502	12v LED
Interior / Other Lights	Bulb type	Bulb rating
Awning lamp, LED with alarm indicator	LED complete unit FEM1225-W	12v LED
Awning lamp without alarm indicator	LED complete unit FEM0945-W	12v LED
Over locker LED strip light	LED strip FEM1214 (cut to length)	12v LED
Forward ceiling LED strip light	LED strip FEM1459	12v LED
Forward ceiling LED strip light	LED strip FEM0937A	12v LED
Kitchen light	LED complete unit FEM1374	12v LED
Locker spotlights with dimmer	LED complete unit FEM1168	12v LED
Downlights, small format	LED complete unit FEM1189	12v LED
Downlight, shower cubicle, 3-stud	LED complete unit FEM0856	12v LED
Ceiling light, White, shower area	LED complete unit S2	12v LED
Illuminated panel or mirror backlight	LED strip FEM1214 (cut to length)	12v LED
Bunk light (touch control)	LED complete unit SMD	12v LED
Wardrobe light	G4 Halogen capsule bulb	12v 5W
Low level walkway light	LED complete unit FEM0993	12v LED
A-Pillar rod lights	LED complete unit FEM1075	12v LED
A-frame lamp (gas locker illumination, Cameo only)	C5W	12v 5W
Low level storage area lamp (Cameo only)	LED complete unit FEM1373	12v CCFL
Feature lighting (i.e. cocktail cabinet light)	LED strip FEM1214 (cut to length)	12v LED

Note: Not all bulbs and lights feature on all models within a range

Conqueror / Elite	Continental / Elegance	Cameo
✓	✓	✓
✓	✓	✓
✓	✓	✓
✓	✓	✓
✓	✓	✓
✓	✓	✓
✓	✓	✓
		✓
✓	✓	✓
		✓
✓	✓	✓
✓	✓	✓
✓	✓	✓
✓	✓	✓
✓		✓
✓		✓
✓	✓	✓
✓	✓	✓
		✓
	✓	✓

Bulb Access

Conqueror - Elite - Elegance - Continental

2016 CONQUEROR / ELITE / CONTINENTAL / ELEGANCE / CAMEO ROAD LIGHT BULB ACCESS

REAR LIGHT CLUSTERS (CONTAINING INDICATOR, TAIL / STOP, REVERSE AND FOG LAMPS):

- These multi-function lights are LED and have no user serviceable parts inside.
- Replacement clusters can be fitted in the following way:
- Remove three screws visible around the perimeter of the cluster
- Pull the cluster away from the rear panel of the tourer, taking care to not put excessive strain on the electrical connections behind the lamp
- Unplug the electrical connection from the rear of the lamp, by releasing the tab and lifting the connector upwards relative to the cluster
- Plug the connector back into the replacement lamp, position the lamp into the recess and replace the three fixing screws.

FRONT LOW LEVEL MARKER / POSITION LAMPS (CLEAR LENSE)

- These lamps are LED and have no user serviceable parts inside.
- Replacements should be undertaken by your dealer, as the lamps are sealed onto the mounting panel.

HIGH LEVEL BRAKE LAMP

- This lamp is single piece and has no user serviceable parts inside.
- Replacements should be undertaken by your dealer, as the lamps are sealed onto the mounting panel.

NUMBER PLATE LAMPS

- Bulb access is from via the front lense of each lamp
- Remove the two screws in the lense of the lamp, and remove
- Lever the bulb out of retaining clips
- Reverse the procedure to re-fit a new bulb and the light lense

SIDE MARKER / POSITION LAMPS (AMBER LENS)

- These lamps are LED and have no user serviceable parts inside.
- Replacements should be undertaken by your dealer, as the lamps are sealed onto the mounting panel.

UPPER SIDE MARKER / POSITION LAMPS (RED AND WHITE LENS)

- Lense is removed from base to access bulb
- Carefully insert small flat bladed screwdriver into recess in lower edge of lamp base. Apply pressure to release locking barb.
- Lift lense upwards and away from lamp base, lower edge first
- Lever bulb out of retaining clips
- Reverse procedure to re-fit bulb and lense