



## Swift Motorhome Owner's Handbook



# THE IDEAL COMBINATION



The pleasures of motorcaravanning start with the motorhome you choose, and you can't make a better choice than Swift.

The unique style of Swift makes them leaders in the coachbuilt market, and Chartered Trust are ideally placed to

help you. We have a wide choice of motor finance programmes, each designed to meet the varied needs of a private or business motorist.



**Chartered Trust**

A Standard Chartered Group company

So, when it comes to motorcaravanning, Chartered Trust can provide the ideal combination.

*Written quotations available on request.*

24-26 Newport Road, Cardiff CF2 1SR  
Telephone: (01222) 296863

## INTRODUCTION

DEAR OWNER

THANK YOU FOR DECIDING TO BUY ONE OF OUR NEW MOTORHOMES. WE ARE SURE YOU WILL ENJOY MANY HAPPY HOURS IN IT AND WE HOPE THE INFORMATION AND HINTS IN THIS HANDBOOK WILL HEIGHTEN YOUR ENJOYMENT.

THE HANDBOOK HAS BEEN DESIGNED TO GIVE YOU A GENERAL GUIDE TO THE CARE, USE AND MAINTENANCE OF YOUR MOTORHOME. WHETHER YOU ARE A NEW OR AN EXPERIENCED MOTORHOME USER THE HINTS WILL HELP TO PROTECT YOUR INVESTMENT.

THE INFORMATION CONTAINED WILL ANSWER MOST OF YOUR QUERIES, BUT IF THERE ARE ANY ASPECTS WHICH ARE NOT COVERED PLEASE CONSULT YOUR APPOINTED DEALER.

HAPPY TOURING!

**IMPORTANT - PLEASE QUOTE THE BODY SERIAL NUMBER & BASE VEHICLE CHASSIS NUMBER IN ALL CORRESPONDENCE WITH YOUR DEALER OR SWIFT GROUP LIMITED.**

All the illustrations and descriptive matter in this handbook are intended to give a general idea of the motorhome. Changing market and supply situations may prevent us from maintaining the exact specification details in this handbook, we therefore reserve the right to alter specifications as materials and conditions demand.

Dealers are not agents of Swift Group Limited and have absolutely no authority to bind Swift Group Limited by any express or implied undertaking or representation.

# CONTENTS

|                                    |           |
|------------------------------------|-----------|
| <b>The Motorhome Code .....</b>    | <b>1</b>  |
| <b>Preparing for the Road.....</b> | <b>5</b>  |
| <b>‘En Route’ .....</b>            | <b>9</b>  |
| <b>Safety &amp; Security .....</b> | <b>11</b> |
| <b>Arrival at Site.....</b>        | <b>13</b> |
| <b>Connecting Services .....</b>   | <b>15</b> |
| <b>Electrical Systems .....</b>    | <b>25</b> |
| <b>Equipment Details .....</b>     | <b>31</b> |
| <b>Motorhome Care.....</b>         | <b>69</b> |
| <b>Useful Information .....</b>    | <b>75</b> |
| <b>Index.....</b>                  | <b>79</b> |

# THE MOTORHOME CODE

|                               |   |
|-------------------------------|---|
| <b>Code of Conduct</b> .....  | 2 |
| <b>The Country Code</b> ..... | 4 |
| <b>The Coastal Code</b> ..... | 4 |

# Motorhome Code

## CODE OF CONDUCT

### CAMP SITES

#### Arrivals

Report to reception immediately on arrival.

#### Vehicle Movement

Keep to roadways unless otherwise directed.

Adhere to speed limits. Note that these are generally 10 mph. (Remember that the stopping distance on grass is considerably greater than on tarmac.)

Only a person in possession of a current driving licence may drive on the site.

Park correctly as advised on your pitch. Where possible leave 20 feet of free space around your vehicle.

#### Use of Site Appliances

Use the electrical mains hook-up in the correct manner and with caution.

Ensure that all fresh water taps/connections are turned off after use.

Have care and consideration when using all facilities (toilets and showers etc) and leave clean and tidy. Young children should be supervised.

### Waste Disposal

If the vehicle is not fitted with a waste water tank, a suitable receptacle should be placed below all waste water outlet pipes. Do not let these containers overflow.

Dispose of all waste water where instructed.

Empty effluent from chemical toilets where instructed.

To avoid possible damage to sewage purification works, only approved chemical fluids must be used. Under no circumstances should coal tar, phenol or caustic-based fluids be used.

Disposable napkins and similar bulky items must not be put into chemical closet emptying points but should be wrapped in a polythene bag and placed in the container provided.

Place all litter in containers marked for the purpose.

### Noise

Do not make excessive noise.

Children should be restrained from making excessive noise.

Flying kites and model aircraft and the use of items like catapults or air-guns, as well as ball games, should not be permitted among, or close to other vehicles.

Musical instruments, record players, radios and televisions should not be used to the inconvenience of other people on the site.

Open and close doors quietly.

Power generators must be adequately silenced and used with consideration.

### Dogs and other Pets

All dogs and other pets should be kept under control.

Unless permission has been granted, no animal should be allowed loose on the site and leads must not exceed 10ft.

No animals should be allowed in the shower/toilet blocks.

Do not let dogs foul the site.

### Fire Precautions

Adhere to and take note of fire precautions noting the whereabouts of the fire points.

**WARNING: Provide one dry powder fire extinguisher of an approved type or complying with ISO 7165, of at least 1kg capacity, by the main exterior door and a fire blanket next to the cooker. Familiarise yourself with the operating instructions on your fire extinguisher and the local fire precaution arrangements.**

## Motorhome Code

When using a dry powder extinguisher it is suggested that the motorhome be evacuated until the powder has settled, to avoid inhalation.

Unless permission has been granted, barbecues should not be used. If permission is given, consideration should be given to the annoyance that can be caused to other users of the site.

Open fires are not allowed.

### **Awnings and Tents**

Awnings and tents should only be used when permission has been obtained.

When on grass and staying for more than a few days, the ground sheet and/or side flaps of awnings should be periodically raised in order to avoid damage to the ground.

### **Departure**

Leave the pitch clean and tidy.

On leaving, check out with reception paying the required fees.

### **WILD CAMPING**

Camping away from licensed sites, without the permission from the land owner or his agents, is not allowed in the United Kingdom.

When permission has been granted, all aspects of this Code should be adhered to.

On no account should:

- (a) Litter be disposed of other than in the receptacles provided.
- (b) Water be allowed to escape from the vehicle.
- (c) Chemical toilets be emptied except into the disposal places agreed with the land owner.
- (d) Washing or similar be hung outside the vehicle.

### **PARKING**

Motorhomes should only be parked in approved places.

When using the facilities of a motorhome care and consideration should be given to those around them.

### **DRIVING**

When using a motorhome on either the public highway or private roads the Highway Code should be complied with and full consideration given to other road users.

In the event of a motorhome travelling slowly the driver of the motorhome should, where possible, pull over in order to let other traffic pass.

When the vehicle is in motion it is compulsory for all front seat passengers to wear seat belts and strongly recommended for rear seated passengers.

Before moving off, elevated roofs should be lowered and correctly secured, and top hinged windows closed. Likewise all doors and access lockers for gas containers and chemical toilets must be properly secured.

Exterior steps should be properly retracted and secured.

When the vehicle is being refuelled, or on a ferry, all gas systems must be turned off.

### **HANDBOOK**

Before using a motorhome all aspects of the handbooks, produced by the chassis manufacturer and the converter, must be read and adhered to.

### **ENVIRONMENT**

Care and consideration should be taken to protect the environment.

Observe the Country and Coastal Codes shown overleaf.

# Motorhome Code

## THE COUNTRY CODE

Enjoy the countryside but respect its life and work.

More people than ever before are exploring the countryside, interested in farming, plant life, bird watching or just observing the general wildlife. Whatever your interest, there is a lot to learn, but please observe the following code.

1. Guard against all risk of fires. Hay and heathland catch alight easily and once ablaze are very hard to put out.

### **REMEMBER: FIRE SPREADS QUICKLY.**

2. Keep to the public paths across farmland.
3. Use gates and stiles to cross fences, hedges and walls.
4. Leave livestock, crops and machinery alone. View from a distance.
5. Take your litter home - it is unsightly and harmful to wildlife.
6. Help to keep all water clean.
7. Take special care on country roads.
8. Make no unnecessary noise. Most animals are very timid; noises can disturb them unnecessarily. If you want to get the best out of the country, go quietly.

## THE COASTAL CODE

As our coastlines are increasingly used for recreation and education, the following suggestions are made to enable us to enjoy our inheritance and preserve it for posterity.

### **Disturbance may mean DEATH.**

DO NOT trample about, or move rocks unnecessarily.

DO NOT frighten seals or seabirds.

DO NOT spill detergents, solvents or fuel from boats as these can kill marine life.

When sailing, moderate your speed - the wash from a fast boat can destroy banks and nests.

Live molluscs and crustaceans need not be collected as souvenirs - dead shells can usually be found.

Shellfish can take years to grow and fines can be imposed for not observing national regulations.

DO NOT pull up seaweeds unnecessarily.

Make your visit instructive - not destructive.

Look at material - don't remove it. Take notes and photographs, not specimens.

Observe by-laws and be considerate to others.

National Trust property and Country Parks have regulations to protect the wildlife. Follow these and the Country and Coastal Codes.

# PREPARING FOR THE ROAD

|   |          |
|---|----------|
| <b>Before Moving Off .....</b>                          | <b>6</b> |
| <b>Loading of Vehicle .....</b>                         | <b>6</b> |
| <b>User Payload Allowance .....</b>                     | <b>6</b> |
| <b>Maximum Technically Permissible Laden Mass .....</b> | <b>6</b> |
| <b>Roof Loading .....</b>                               | <b>7</b> |
| <b>Tyres .....</b>                                      | <b>7</b> |

# Preparing for the Road

## BEFORE MOVING OFF

### Check:

- gas cylinders and all gas operated appliances have been isolated, including fridge, water heater, oven and space heater.
- loose articles are stowed securely. Do not stow tins, bottles or heavy items in overhead lockers.
- all lockers and cupboard doors are closed and secured.
- all bunks and ladders are secure. Place Luton ladder on its side in front of Luton bedboards.
- all rooflights are closed and secured.
- main table is stored in its transit position.
- fridge is on 12V operation and door lock is set.
- gas cylinders are correctly positioned, secured and turned off.
- battery selection switch is in the OFF position.
- tyre pressures and wheel nuts.
- rear corner steadies are raised.
- all drain taps are closed.
- 240V mains input socket flap is securely closed.

Special attention must be taken to ensure all top hinged windows as well as the Luton windows are closed when in transit. All units should be fully closed and latched to prevent damage. The motorhome exterior door should also be locked.

## LOADING OF VEHICLE

Correct weight distribution is an important factor in ensuring your vehicle is well balanced and easy to drive. It is therefore necessary to load your motorhome carefully making sure all heavy articles are evenly distributed and are preferably placed in the lower lockers or bed boxes.

Although it is essential to ensure that the total weight of your motorhome does not exceed the stipulated Maximum Technically Permissible Laden Mass, (M.T.P.L.M.), it is important to remember that the front and rear axles also have individual maximum weights which must not be exceeded.

These weights, together with the M.T.P.L.M., can be found on the Fiat/Peugeot/VW, the Swift Group or Al-Ko plates affixed to your vehicle under the front edge of the bonnet.

**WARNING: Isolate all gas appliances before moving off.**

## USER PAYLOAD ALLOWANCE

The User Payload (the weight of additional items such as personal effects, essential habitation equipment and optional equipment, etc.) is calculated by deducting the Mass in Running Order (manufacturer's standard vehicle specification weight) from the Maximum Technically Permissible Laden Mass (manufacturer's maximum authorised weight).

### NOTICE:

Please ensure you have allowed for the masses of all the items you intend to carry in your motorhome.

## MAXIMUM TECHNICALLY PERMISSIBLE LADEN MASS

This is the maximum legally allowable weight of the vehicle, fully laden, on the road.

See Specification pages for specific model weights.

### ROOF LOADING

A maximum load of 200kgs can be evenly distributed over the roof area. This figure **MUST NOT** be exceeded.

The roof areas, up to the over cab section, are capable of withstanding an average person's weight (13 stone or 82.5kg).

**Note:** Do not walk on the over cab section.

Some motorhome roofs can be fitted with a roof rack (optional).

It is permitted to stand inside the roof rack fitted to the roof. The roof section beyond the rack is not designed for walking on.

**Note:** When loading the roof rack, make sure the load is spread evenly and do not allow sharp objects to come into contact with the roof surface.

**WARNING: When walking on the roof rack, deck type shoes should be worn - not leather soles.**

### TYRES

The law requires that the tyres and pressures must be suitable for the use to which they are being put. The minimum tread depth must be 1.6mm throughout a continuous band comprising the centre three-quarters of the breadth of the tread and around the circumference of the tyre.

**'EN ROUTE'**

**Spare Wheel Removal ..... 10**

# 'En Route'

## REMOVAL OF SPARE WHEEL:

**Caution:** Exercise care when lowering the wheel and frame due to its weight.

### Removal

- a) Spare wheel in the stowed position (Fig. 1).
- b) Remove the securing pins (a) from the supports (b) at each side of the spare wheel carrier frame (c) (Fig. 2).
- c) Lift the wheel carrier frame (c) slightly and move the frame supports (b) forward and clear of the carrier frame (Fig. 3).
- d) Lower the carrier frame and wheel to the ground (Fig. 4).
- e) Remove the spare wheel.

### Replacement

Replacement is a reversal of the removal procedure.

Ensure the securing pins (a) are correctly located in the frame supports (b).

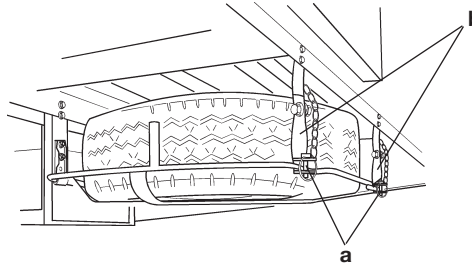

Fig.1

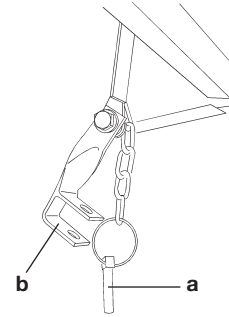

Fig.2

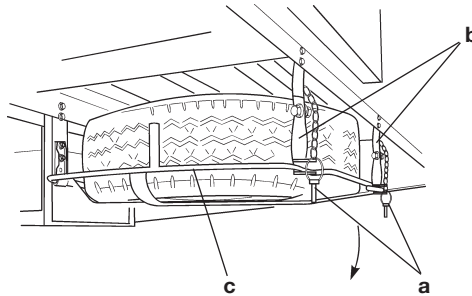

Fig.3

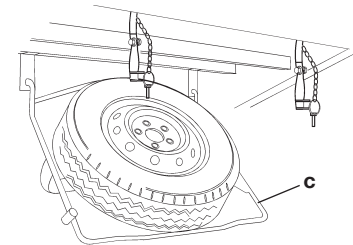

Fig.4

# SAFETY & SECURITY

|                              |    |
|------------------------------|----|
| <b>In Case of Fire</b> ..... | 12 |
| <b>Ventilation</b> .....     | 12 |
| <b>Security</b> .....        | 12 |

## Safety & Security

**IMPORTANT: Your attention is drawn to the notice affixed in your motorhome advising you on fire prevention, ventilation and what to do in case of a fire.**

### FIRE

#### In case of fire

1. Get everyone out of the motorhome as quickly as possible using whichever exit is quickest including windows. Do not stop to collect any personal items.
2. Raise the alarm. Call the Fire Brigade.
3. Turn off gas supply valve, if safe to do so.

#### Fire Extinguishers (if fitted)

It is recommended that a 1kg (2lb) minimum capacity dry powder fire extinguisher complying with the requirements of ISO 7165 be carried inside your motorhome at all times and a fire blanket be kept next to the cooker.

A fat pan fire should not have an extinguisher aimed at it but be smothered with a fire blanket.

#### Children

Do not leave children alone in the motorhome in any event. Keep potentially dangerous items out of reach as at home, e.g. matches, drugs, etc.

#### Escape Paths

It is important that you do not block escape paths to emergency exits with obstructions or hazards.

### VENTILATION

All motorhomes are built to EN 721. The ventilation points on your motorhome are fixed points of ventilation which are stated by this standard. Under no circumstances must these vents be blocked or obstructed.

All ventilation levels are calculated to suit each models requirements. There should be no modifications made which may result in reduced ventilation levels.

Ventilation is provided at low level by vents fitted either to the furniture or in the entrance step, and at high level by the roof lights.

It is advised that fixed ventilation points are checked and cleaned (if necessary) on a regular basis with a small brush or a vacuum cleaner.

**WARNING: NEVER use portable cooking or heating equipment other than electric heaters that are not of the direct radiant type, as it is a fire and asphyxiation hazard.**

NEVER allow modification of electrical or LPG systems and appliances except by qualified tradesmen at a Swift Group Dealer

In the interests of safety, replacement parts for an appliance should conform to the appliance manufacturers specification and should be fitted by them or their authorised agent.

Additional night time ventilation is obtained

on some windows by releasing the window catches and placing them in the second groove. Note the windows are not sealed from rain in this position.

**WARNING: Do not obstruct ventilation**

### SECURITY

#### Motorhome Theft

The theft of a motorhome can occur in the most unlikely circumstances; from a motorway service area or even an owner's driveway.

Secure all windows and doors when your motorhome is unoccupied even if only for a short length of time.

#### Chassis number

Record your motorhome chassis number, which can be found under the bonnet, and the body conversion serial number.

Make a note of these numbers in the space provided at the rear of this handbook and make a separate note of the numbers to keep safe at home.

#### Additional security

Window etching of the chassis number is a cost effective deterrent.

Free crime prevention advice about securing your motorhome, protecting your valuables, property marking either at home or whilst on site, can be obtained from the Crime Prevention Officer through your local Police station.

# ARRIVAL AT SITE

|  |           |
|--|-----------|
| <b>Positioning the Motorhome .....</b> | <b>14</b> |
|--|-----------|

## Arrival at Site

**Note:** Check and observe site regulations.

### POSITIONING THE MOTORHOME

Keep to roadways unless otherwise directed. Adhere to speed limits. Note that these are generally 10mph.

**(Remember that the stopping distance on grass is considerably greater than on tarmac.)**

Only a person in possession of a current driving licence may drive on the site.

#### Selecting a pitch

Do not pitch in such a position that your motorcaravan will obstruct others coming in.

Try to choose an area which is dry, reasonably level and preferably with a hard base.

If you have no alternative but to pitch on a slope try to ensure that you are facing down the slope, for when you leave.

#### Levelling the motorhome

Levelling must be carried out in both directions for the refrigerator and other equipment to function correctly. Stepped levelling boards (Fig. B) or proprietary ramps are ideal for this purpose.

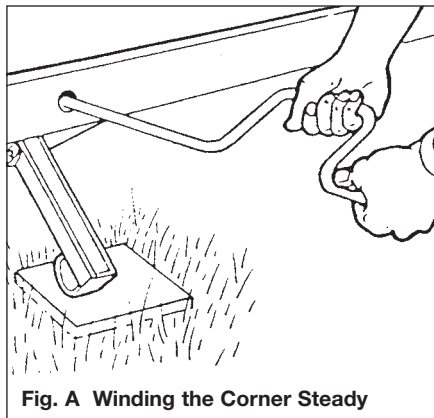

**Fig. A Winding the Corner Steady**

Lower the rear corner steadies (if fitted) until they are in firm contact with the ground (Fig. A). DO NOT use the steadies as a jack, they are only a means of stabilising the rear of the motorhome. Levelling pads or boards should be used under the steadies where the ground is soft or uneven.

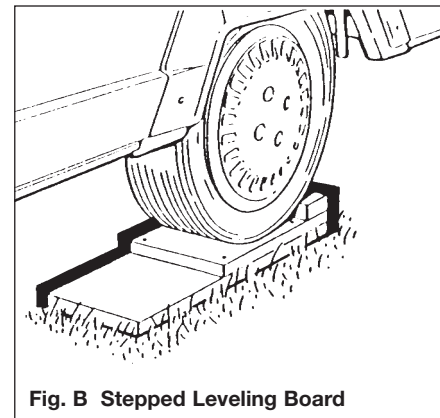

**Fig. B Stepped Leveling Board**

#### Awnings and Tents

Awnings and tents should only be used when permission has been obtained. When on grass and staying for more than a few days the ground sheet and/or side flaps of awnings should be periodically raised in order to avoid damage to the ground.

# CONNECTING SERVICES

|  |    |
|--|----|
| <b>Mains Socket/Water Connection</b> .....               | 16 |
| <b>Water System</b> .....                                | 16 |
| <b>Gas</b> .....   | 18 |
| Types of Gas .....                                       | 18 |
| Safety Advice .....                                      | 19 |
| <b>Electricity</b> .....                                 | 20 |
| <b>Overseas Connection</b> .....                         | 21 |
| <b>Wiring Diagram</b> .....                              | 22 |
| <b>230V Mains Electrical Equipment Consumption</b> ..... | 23 |

## Connecting Services

Connection of services are dealt with under separate headings. In all cases become familiar with manufacturers' instructions.

**Before making connections of any description to the motorhome ensure ALL equipment is turned off.**

### WATER SYSTEM

#### Fresh water system

- (i) All fittings, including the holding tank, water pipes, taps and connections are of food quality material (to BS6920) and therefore, should not affect the quality of the water used. It is recommended however, that the system is flushed through twice before it is used for the first time, and always cleaned/flushed after it has stood unused for a period of time (eg over the winter period). Care has been taken (using smooth bore pipes etc) to eliminate as many water traps as possible.
- (ii) When filling the fresh water system remember to check that the water source is suitable for use as drinking water and, if you are using a hosepipe or water carrier, that it is also made from non-toxic materials (preferably food quality material).
- (iii) The fresh water tank may be drained via a small tap located next to the water

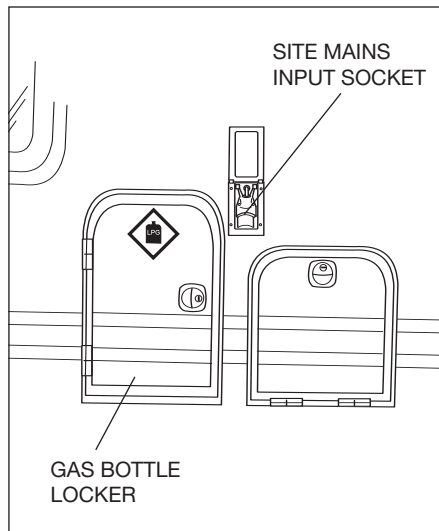

tank or via any one of the sink/shower taps through the normal waste water system.(iv) The fresh water system is pressurised by a pump which will continue to operate until it senses a pre-set pressure in the system.

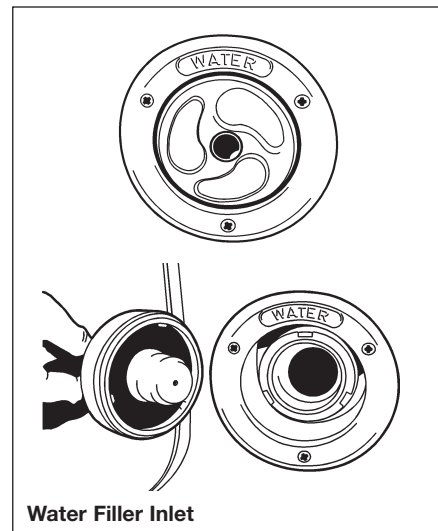

**WARNING:**  
If the fresh water tank is completely empty the pump will be unable to pressurise the system and will operate continuously. In this situation it is essential that, in order to avoid damage to the pump, it is switched off using the pump isolator switch on the KT9M5 distribution panel until such time as the water tank has been filled.

## Connecting Services

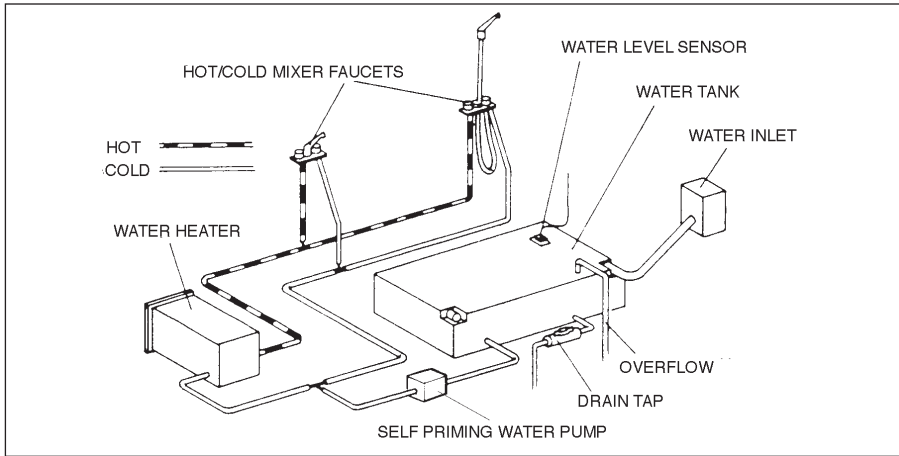

prevent tainting of the water. Remember, if the water heater has been drained it will require two gallons of water to fill it. To do this open all hot water taps (except shower) until water comes from the taps. Top up fresh water tank after priming the water system.

Please ensure all taps are fully turned off when not in use.

We recommend the use of Milton 2 sterilising fluid for cleaning and sterilising the water tank and system.

An explanatory leaflet is available from:  
The Milton Food Hygiene Advisory Service,  
Whitehall Lane, Egham, Surrey, TW20 9NW.

### Waste water system

- (i) The waste water holding tank is secured underneath the chassis of your motorhome and is gravity fed.
- (ii) In order to eliminate, as much as possible, waste water traps and unpleasant odours, only smooth bore pipes are used. However, should the waste water tank be overfilled, then the waste water will backfill the drain pipes until it eventually appears in the shower base. In order to prevent this, please take note of part (iii).
- (iii) The waste water gauge only shows

when the tank is full, not progressively and it is, therefore, recommended that the waste water tank is emptied on a daily basis. This is done by opening the valve located just beneath the side or rear panel on the exterior of the motorhome. It should be emptied either directly, or via a waste water container (not supplied) into a designated waste water area.

### Fresh Water Tank

Your motorhome is fitted with a water tank filled from the outside via a lockable water filler cap. When filling, use a hose manufactured from non toxic material, to

## Connecting Services

### GAS

#### GENERAL INFORMATION

##### Gas Bottles

Bottled Liquefied Petroleum Gas (L.P.G.) is the most convenient portable source of fuel for your motorhome.

Make sure that heating, cooking appliances and gas cylinders are switched off before you move the motorhome.

Regularly check flexible gas hose, joints and connections for tightness. Finally make sure that each gas appliance is working efficiently to the recommendations of the appliance manufacturers.

The gas bottle locker on your motorhome is designed to accommodate 4.5kg, 7kg or 15kg Butane or 6kg or 13kg Propane cylinders.

##### The regulator

The regulator (Fig. A) is a governing device which adapts the bottle pressure to one that suits the equipment in the motorhome.

**WARNING: Some industrial LPG appliances operate at high pressure and require a 'high pressure' regulator. This often has an adjusting handle on it. NEVER use such a regulator on a motorhome.**

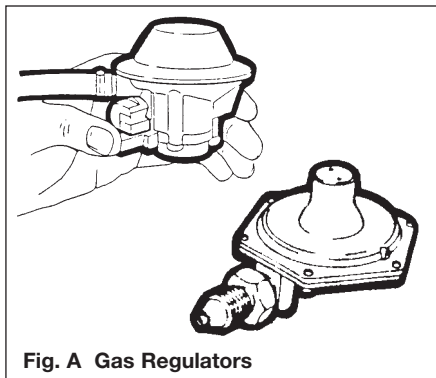

Fig. A Gas Regulators

**Note: Regulator valves should always be turned to the "OFF" position whilst the motorhome is being driven.**

Propane and Butane gas regulators are not interchangeable.

##### Hoses

Hoses should be made from Neoprene and should conform to BS 3212. Rubber hosing should never be used. It is good practice to replace hoses annually and in any case no later than the expiration date marked on the hose. An approved hose clip is a worthwhile addition to prevent accidental removal of the hose.

### TYPES OF GAS

#### Butane

Butane is supplied in the U.K. in green, blue or aluminium bottles.

All these have a male left hand thread EXCEPT for Camping Gaz which has a special female right hand thread and Calor, 4.5kg, 7kg & 15kg, aluminium and 33lb/15kg bottles which have a special clip-on connection.

Continental bottles usually have a male left hand thread similar to but not identical with U.K. Butane.

Butane is suitable for use at temperatures down to 2°C but will not work below that.

#### Propane

Propane is supplied in red, or partly red bottles which have a female left hand threaded connector.

Scandinavian countries use the same connector.

Germany and Austria supply Propane with a male connection.

Propane will work at temperatures as low as -40°C and is therefore suitable for all winter motor caravanning.

## Connecting Services

### GAS SAFETY ADVICE

#### Facts about LPG

LPG is not poisonous.

Bi-products are harmless.

There is danger if all air and oxygen are excluded.

(Ventilation holes must be kept clear at all times).

LPG has been given a smell by the manufacturers in order to identify leaks.

#### Awning Spaces LPG Appliance Exhaust

There is no danger of pollution of an enclosed awning space by the LPG exhaust from a refrigerator venting into it.

Space heaters may produce sufficient exhaust to pollute the awning space, if it is totally enclosed, from a general comfort, smell and hygiene point of view. In extreme cases there could be a build up of carbon dioxide to a dangerous level.

Motorhome owners are advised to allow some fresh air circulation in the awning space when such appliances are in use.

### PRECAUTIONS

- a) Never look for a leak with a match.  
Always use a soap solution or its equivalent when testing connections.  
Do not operate any electrical apparatus whatsoever, especially light switches.

If the leak is not obvious, the motorhome should be evacuated and qualified personnel consulted.

- b) Avoid naked lights when connecting or changing a cylinder.
- c) Check the flexible hose frequently.
- d) Gas is heavier than air and therefore sinks to the lowest point.
- e) Keep bottle gas containers outside (and protected against frost). If they must be kept inside make sure they are well away from heat.

**WARNING: If you smell gas or suspect a leak and if it is safe to do so, isolate the gas appliances and turn off the gas bottles at the regulator. Evacuate the motorhome and ventilate the vehicle. Seek professional advice as to the cause of the leak.**

**WARNING: Inspect flexible gas hose regularly for deterioration and renew as necessary, with the approved type, in any case not later than the expiry date marked on the hose. Flexible gas hose length should not exceed 400mm.**

#### Ventilation

Vents should not be obstructed in any manner as this could lead to insufficient fresh air. In this case the confined

atmosphere becomes depleted of oxygen which leads to the formation of the highly poisonous gas 'carbon monoxide'. Carbon Monoxide is odourless, colourless and tasteless and will rapidly cause unconsciousness and death with little or no warning prior to collapse.

**THERE IS NO DANGER WHEN ADEQUATE VENTILATION IS PROVIDED.**

#### Roof-mounted Flue Installations

All flue installations should be inspected once a year throughout their length for corrosion. Flues should be replaced if any sign of perforation is found. Ensure that the replacement is of an approved type.

#### Connection

Ensure that the gas regulator is correctly connected to the gas cylinder in the gas bottle compartment and that the hose is tight. Before turning on the gas supply, ensure that all gas operated equipment in the motorhome is turned off.

#### Gas Tap Colours

All gas equipment is supplied through a gas manifold system which has individual isolation taps for each appliance as follows:

|        |   |                          |
|--------|---|--------------------------|
| Red    | - | Water Heater             |
| White  | - | Space Heater             |
| Green  | - | Hob & Oven (combination) |
| Green  | - | Hob (separate)           |
| Yellow | - | Oven (separate)          |

# Connecting Services

## ELECTRICITY

As with electricity in the home, care must be exercised when handling mains electricity.

Your attention is drawn to the following notice as laid down by the Institute of Electrical Engineers.

### INSTRUCTIONS FOR ELECTRICITY SUPPLY

#### On arrival at site

1. Before connecting the motorhome installation to the mains supply, check that:
  - (a) the mains supply is suitable for your installation and appliances, i.e. whether it is a.c. or d.c. and whether it is at the correct voltage and frequency, and
  - (b) your installation will be properly earthed. Never accept a supply from a socket outlet or plug having only two pins, or from a lighting outlet.
  - (c) any residual current device (earth leakage circuit breaker) in the mains supply to the motorhome has been tested within the last month.

In case of doubt, consult the site owner or his agent.

2. MAKE SURE THAT THE SWITCH AT THE SITE SUPPLY POINT IS OFF.
3. Lift the cover of the electricity inlet provided on the motorhome, and insert the connector of the supply flexible cable.
4. Remove any cover from the socket outlet provided at the site supply point, and connect the plug at the other end of the supply flexible cable to this. Switch on the main switch at the site supply point.

#### On leaving site

5. Switch off the main switch at the site supply point and remove the flexible cable connector replacing any cover fitted.
6. Disconnect the flexible cable from the motorhome.

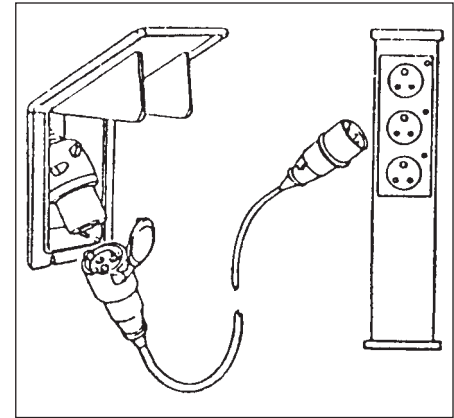

**IT IS IMPORTANT THAT THE MAIN SWITCH AT THE SITE SUPPLY POINT SHOULD BE SWITCHED OFF, THE SUPPLY FLEXIBLE CABLE DISCONNECTED, AND ANY COVER REPLACED ON THE SOCKET OUTLET AT THE SITE SUPPLY POINT BEFORE DISCONNECTING THE FLEXIBLE CABLE FROM THE MOTORHOME. IT IS DANGEROUS TO LEAVE THE SUPPLY SOCKET OR SUPPLY FLEXIBLE CABLE LIVE.**

For motorhomes that are generally left unused for long periods in the open it is strongly advised that the mains installation is inspected periodically to ensure that it is safe to use. The IEE Wiring Regulations recommend that mains installations in motorhomes are re-inspected every 3 years. An annual inspection by a qualified person is recommended (see list below) who should sign and issue a periodic inspection report.

Suitably qualified persons acceptable to the SMMT/NCC to sign and issue Inspection and Completion Certificates should be one of the following:

- An approved contractor of the National Inspection Council for Electrical Installation Contracting\* or
- A member of the Electrical Contractors' Association of Scotland
- A qualified person acting on behalf of the above (in which event it should be stated for whom he is acting).

\* The names and addresses of Approved Contractors in any locality (there are over 10,500 in the UK) can be obtained from Electricity Shops, or direct from:

NICEIC  
Vintage House  
37 Albert Embankment  
London SE1 7UJ  
Telephone: 0171 582 7746

The names and addresses of members of the Electrical Contractors' Associations can be obtained direct from:

ECA  
Esca House  
Palace Court  
London W2 4HY  
Telephone: 0171 229 1266

ECA of Scotland  
23 Heriot Row  
Edinburgh EH3 6EW  
Telephone: 0131 225 7221

**IN CASE OF DIFFICULTY CONSULT AN APPROVED ELECTRICAL INSTALLATION CONTRACTOR (WHO MAY BE THE LOCAL ELECTRICITY COMPANY). IT IS DANGEROUS TO ATTEMPT MODIFICATIONS AND ADDITIONS YOURSELF. LAMPHOLDER-PLUGS (BAYONET CAP ADAPTORS) SHOULD NOT, IN ANY CIRCUMSTANCES, BE USED.**

### OVERSEAS CONNECTION

Note: Connection to a mains voltage supply OVERSEAS requires particular attention.

Care must be taken when connecting supplies abroad since the supplies can be of REVERSE POLARITY.

The significance of REVERSE POLARITY is that when equipment is switched off it may not be electrically isolated.

The only certain way of making equipment safe is to unplug it.

If electrical polarity indication is not included in your motorhome electrical equipment, it is useful to have a means of checking polarity of the mains supply, especially when touring overseas.

There are available several proprietary makes of equipment for the purpose.

If it can be achieved, it is preferable to connect live to live, and neutral to neutral to maintain full electrical protection.

CHECK all motorhome equipment is set-up to accept the site supply before actually switching on.

# Connecting Services

## WIRING OF CONNECTING CABLE AND MOTORHOME MAINS INLET

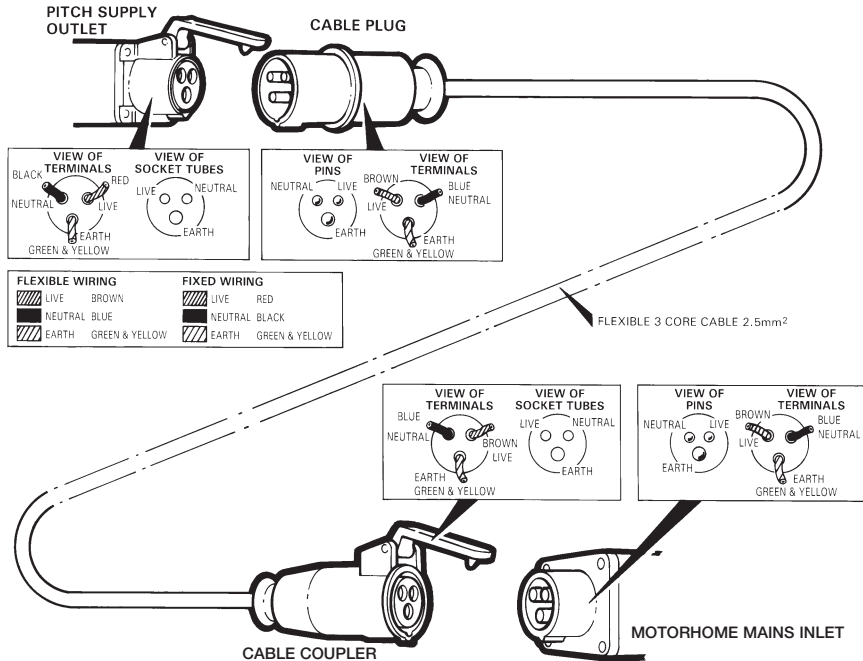

### WARNING

IT IS ESSENTIAL THAT CONNECTIONS ARE MADE EXACTLY AS SHOWN. IF TERMINAL MARKINGS ARE NOT IN ACCORDANCE WITH THE DIAGRAM THEY MUST BE IGNORED. IF IN DOUBT CONSULT A QUALIFIED ELECTRICIAN.  
THE LEGAL MAXIMUM LENGTH OF THE MAINS INLET CABLE IS 25 METRES. WHEN IN USE IT MUST BE FULLY UNCOILED.

## 230V MAINS ELECTRICAL EQUIPMENT POWER CONSUMPTION

### Please note:

It is possible that the 230V mains electrical equipment may not all operate simultaneously. A typical UK motorhome site mains hook up point provides a maximum output of 10 amps and on some continental sites the available output may be as low as 5 amps. If your loading exceeds the site supply it may trip the site circuit breaker. Please check the available mains output with your site operator.

The following items need to be added together if used simultaneously.

### 230V Mains equipment typical consumption figures:

|                               |              |
|-------------------------------|--------------|
| Carver Cascade 2 water heater | 3.6A approx. |
| Travelling kettle             | 3.2A approx. |
| Battery charger               | 1.0A approx. |
| Portable colour TV            | 0.3A approx. |
| 60w light bulb                | 0.3A approx. |
| Fanmaster on position 4       | 8.3A approx. |
| Fanmaster on position 2 or 3  | 4.2A approx. |

## THERMAL INSULATION AND HEATING

Your motorhome has been designed to achieve a thermal insulation and heating level for specific climatic conditions. The classifications are as follows:

### Grade 1

A motorhome with an average thermal transmittance (u) that does not exceed 1.7w/(m<sup>2</sup>K).

### Grade 2

A motorhome with an average thermal transmittance (u) that does not exceed 1.7w/(m<sup>2</sup>K) and which can achieve an average temperature difference of at least 20K between inside and outside temperatures when the outside temperature is 0°C.

### Grade 3

A motorhome with an average thermal transmittance (u) that does not exceed 1.2w/(m<sup>2</sup>K) and which can achieve an average temperature difference of at least 35K between inside and outside temperatures when the outside temperature is -15°C.

# ELECTRICAL SYSTEMS

|  |    |
|--|----|
| <b>Motorhome Battery</b> .....               | 26 |
| <b>Fault Finding</b> .....                   | 26 |
| <b>Mains Unit (CEC 225)</b> .....            | 27 |
| <b>12V Power System</b> .....                | 28 |
| <b>Transformer/Charger Unit KT12SM</b> ..... | 28 |
| <b>KT9M5 Distribution Panels</b> .....       | 29 |
| Operation .....                              | 29 |
| Fuses .....                                  | 29 |
| <b>Generator Guidelines</b> .....            | 30 |

# Electrical Systems

## MOTORHOME BATTERY

It is recommended that a good quality leisure battery is always in circuit when the system is in use.

A deep cycling heavy duty 12V battery should be used to provide power for lights and other electrical appliances. A proprietary brand leisure battery with either a 60, 75 or 90A capacity is recommended. (It must have tube venting capability for internal battery boxes.)

It should be remembered that batteries suitable for the electrical demands of a motorhome differ in design from those for use with a car, and whilst the system may operate with a car battery, it is strongly recommended that only a leisure type battery, maintained in good condition is used.

The battery should be vented to the outside and should be properly secured. When connecting the battery, ensure that the correct polarity is observed (black is negative and red is positive), and that the terminals are securely fastened.

Under normal circumstances it should not be necessary to remove the battery other than for routine inspection of terminals.

**WARNING: Explosive gases may be present at battery - prevent flames and sparks.**

**Do not store highly flammable materials or pressurised containers in this area.**

**WARNING: Smoking is prohibited around the battery compartment**

Your motorhome has been fitted with an in-line fuse next to the + battery terminal. It is recommended that the rating of the fuse fitted in this location does not exceed 20A.

Where a second battery is factory supplied please note that this is NOT charged.

When fitting the battery, ensure that the correct polarity is observed and that terminals are securely fastened.

Ensure the battery is secured with the strap provided.

## FAULT FINDING

### 1. Mains supply

If mains supply is not available when mains switch and MCB's are switched on, check supply at site distribution and/or mains lead and connections.

### 2. Earth faults or MCB tripped

See RCD/MCD Section.

- 3. Charger switch fails to illuminate**  
Check mains supply as for No.1 and 2.
- 4. Battery discharged or not charging with charger on**  
Check battery terminals.
- 5. 12V distribution circuit failure**  
Check and replace relevant DC output fuse as required.
6. Consult the manufacturers regarding any further difficulties, in particular those related to mains voltage section.
7. There are no user-serviceable or replacement parts in the PMS. All service of this nature should be referred to the manufacturers.

**Note:** Never use a mains supply lead whilst coiled. Always uncoil the full length before connecting to the supply and remember to protect the cable from traffic.

PLUG-IN-SYSTEMS LIMITED PROVIDE AN ON-CALL SERVICE FOR WARRANTY OR NON-WARRANTY REPAIRS.

IF YOU WISH TO TAKE ADVANTAGE OF THIS SERVICE FOR PLUG-IN-SYSTEMS EQUIPMENT ONLY:

Telephone: (01482) 652523 and ask for PRODUCT SUPPORT SERVICE.

## MAINS UNIT (CEC 225)

This acts as the main switch for the motorhome allowing isolation of all circuits. It forms part of the Power System along with the KT12SM Transformer/Charger Unit (if fitted).

The mains unit replaces the conventional fusebox. Similar, but larger ones are often fitted in new houses.

The unit gives both overload (MCBs) and earth leakage protection (RCD) for the electrical supply in your motorhome.

For normal operation all switches on the unit need to be in the ON position. The switches on the left of the unit are known as MCBs (miniature circuit breakers).

These take the place of the conventional fuse but are more convenient.

Note: Having too many appliances switched on at the same time will trip the MCBs. This is a safety measure. (For appliance ratings, see mains consumption, below).

In the event of a fault the MCB 'trips' i.e. automatically moves to the OFF position.

After elimination of the fault the MCB can be re-set by switching to the ON position, (against the spring pressure in an upwards direction).

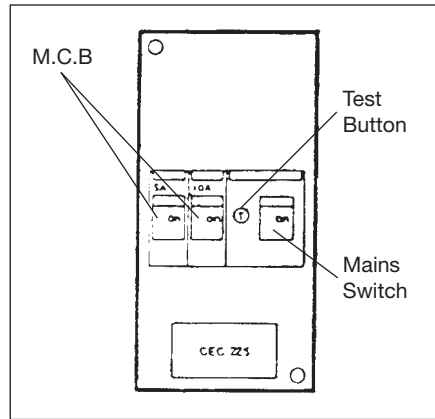

If an earth fault develops or a person touches a live piece of equipment the leakage of current to earth should immediately operate the RCD (residual current device) and 'trip' the main switch, to the OFF position.

This switch is only re-settable after elimination of the fault.

To re-set, operate the switch as for MCB's.

Periodically the RCD should be checked by operating the test button marked 'T'. The unit should immediately switch to the OFF position. If the unit does not switch off then a qualified electrician should be consulted.

If the unit does switch off, the test is complete and the switch can be re-set restoring the supply back to normal.

Add together the current ratings for each electrical appliance you wish to use simultaneously and ensure the total does not exceed 10A. You will find the following table a useful guide to typical values.

### 220/240V MAINS CONSUMPTION

|              |       |
|--------------|-------|
| FRIDGE       | 0.5A  |
| CHARGER      | 0.5A  |
| WATER HEATER | 2.75A |

Formula for calculating current consumption of appliances:

$$\frac{\text{Watts}}{\text{Volts}} = \text{Amps}$$

# Electrical Systems

## 12V POWER SYSTEM

**Note:** The connection of the battery charger to the mains supply is in accordance with the Regulations for Electrical Installations 16th Edition (IEE Wiring Regulations) BS 7671: 1992.

The Power System is supplied fitted remotely in a convenient position and comprises:

- (a) Mains Unit (CEC 225)
- (b) Transformer/Charger Unit KT12SM

## TRANSFORMER/CHARGER UNIT KT12SM

The KT12SM transformer/charger unit has important safety features:

- Overload protection
- Short circuit protection
- Reverse battery polarity protection

The unit has been designed not only to operate as a battery charger, but also for use as a power supply, should a 12V DC battery not be present in circuit. It is, however, recommended that a good quality leisure battery is installed.

Once connected to a 240V/220V mains supply and switched on, its operation is fully automatic.

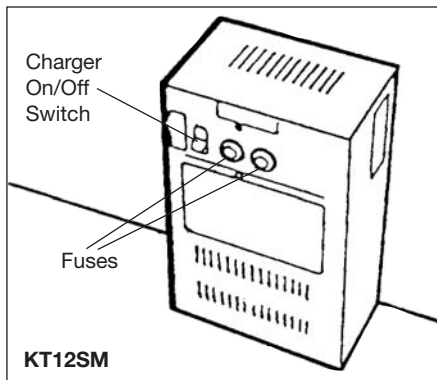

To charge either battery, position the battery selector switch to the appropriate position (See KT9M5, page 33).

When used as an alternative DC power supply, with no battery in circuit, the KT12SM will supply a suitable output for use with pump, lighting, T.V., radio etc. Should the unit become overloaded the 12A DC fuse will blow. Removal of the overload or fault allows the unit to return to normal operation, after replacing the DC fuse. A 1A anti-surge AC fuse is provided as further protection.

Under normal circumstances the total load required by motorhome equipment should not produce an overload situation.

The facility for drawing 12V supply from the cab battery is intended for standby situations only, and care should be taken not to run the cab battery too low.

If the cab battery has been used on site, then the engine driven alternator will recharge both it and the caravan battery whilst travelling.

However, once the cab battery is fully charged, the alternator will supply a trickle charge only to the caravan battery.

This will take place regardless of the position of the battery selector switch on the KT9M5 distribution panel.

## KT9M5 DISTRIBUTION PANEL

The 12V distribution panels have the following facilities:

1. Battery Condition Indicator
2. Battery Selector Switch
3. Water Level Indicator
4. Water Level Selector Switch
5. Pump Isolation Switch

### OPERATION

#### Battery Condition Indicator and Selector Switch

1. Select supply from either MOTORHOME AUXILIARY or CAB battery by use of the 3 position switch.
2. Switch 240V charger off. Check that the meter-needle moves into the yellow or green sectors of the scale, indicating satisfactory state of battery charge. Red sector indicates charging is required.

12V DC power is now distributed to all circuits.

If the central OFF position is selected, both MOTORHOME AUXILIARY and CAB battery supplies are switched off. If however, mains supply is connected, a 12V supply will still be available direct from the transformer/charger unit.

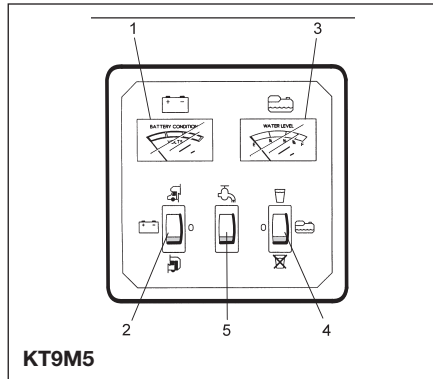

#### Water Level Indicator and Selector Switch

1. Select supply from either MOTORHOME AUXILIARY or CAB battery by use of the 3 position switch.
2. Move the water level selector switch to the right or down to obtain a reading on the level indicator of the contents of the waste water tank (when fitted). The gauge only shows when the tank is full.
3. Move the selector switch to the left or up to obtain a reading of the contents of the fresh water tank.
4. The central OFF position isolates both water level sensors, and no reading will be shown on the indicator.

## FUSES

Each 12V circuit is protected by a blade fuse of the appropriate rating. These fuses can be found in the PMS4 unit or in the fuse-block in the wardrobe. The refrigerator fuse is mounted under the bonnet in all models.

If it is necessary to replace a fuse the current rating, which is marked on the fuse end cap, must be STRICTLY observed.

Should a replacement fuse blow immediately after fitting, under NO CIRCUMSTANCES should it be replaced again without first investigating the cause of the problem.

**WARNING: Do not start your motor-home engine if the mains supply is connected. If the engine is started with KT12SM/PMS4 switched on and the KT9M5 switched to CAB then the output fuse will blow on the KT12SM/PMS4.**

## GENERATOR GUIDELINES

- Lack of regular servicing can be the cause of most generator problems, gensets under 2kW are mainly dependent on engine speed for output frequency and voltage. Poor or no servicing may cause the engine speed governor to run the genset engine too fast. Therefore, frequency and output voltage can rise above the specification of the machine data plate i.e. 240V at 50Hz. This may cause damage to electrical/electronic equipment (such as battery chargers).
- A generator should always run for a few minutes prior to connection with the motorhome electrics, to allow it to warm up and the output to settle to a steady level.
- The AC output of generators is often derived from an AC alternator, rectified to DC then inverted back to AC. In essence this means the output sinewave may not be very smooth and may not run sophisticated electronics efficiently. Some of the new wave of gensets are more sophisticated in their production of a sinewave output and are more suited to run electronic equipment.
- If in doubt consult your genset dealer or manufacturer for advice.

# EQUIPMENT DETAILS

|   |    |
|---|----|
| <b>Water Pump (Shurflo)</b> .....           | 32 |
| <b>Water Pump (Whale)</b> .....             | 32 |
| <b>Cascade 2GE Water Heater</b> .....       | 32 |
| <b>Carver P4 Blown Air Heating</b> .....    | 33 |
| <b>Refrigerators</b> .....                  | 34 |
| Model RM4361 .....                          | 34 |
| Model RM4201 .....                          | 35 |
| Model RM4200 and RM4262 .....               | 36 |
| Model RM4401 .....                          | 37 |
| Model RM4505 .....                          | 38 |
| Model RM4291 .....                          | 41 |
| Travel Catches .....                        | 42 |
| <b>Stoves Combination Oven</b> .....        | 43 |
| <b>Stoves 8000/9000 Cooker</b> .....        | 44 |
| <b>Stoves Vanette Hob &amp; Grill</b> ..... | 46 |
| <b>Cramer Hob</b> .....                     | 47 |
| <b>Thetford Cassette C-200</b> .....        | 49 |
| <b>Thetford Cassette Porta Potti</b> .....  | 52 |
| <b>Heating</b> .....                        | 56 |
| Trumatic C3400 & C6000 .....                | 56 |
| Carver Space Heaters .....                  | 59 |
| Carver 2000P, A & Fanmaster .....           | 59 |
| Carver 4000P, A & Fanmaster .....           | 62 |
| <b>Butterfly Outlets</b> .....              | 64 |
| <b>Side Locker</b> .....                    | 64 |
| <b>Front Swivel Seat</b> .....              | 64 |
| <b>Bedding</b> .....                        | 65 |
| <b>Tables</b> .....                         | 65 |
| <b>Rooflights &amp; Windows</b> .....       | 66 |
| <b>Ash Framed Doors</b> .....               | 67 |
| <b>Shower</b> .....                         | 67 |

## Equipment Details

### IMPORTANT

To maximise the use and life of all fitted equipment in your motorhome it is essential that any accompanying manufacturers' literature is read fully. All recommended maintenance and preparation procedures should be followed. The information provided in this handbook is only intended as a guide. If in any doubt consult your Swift Group appointed dealer, particularly before attempting to install EXTRA EQUIPMENT.

### SHURFLO WATER PUMP

This pump is a completely sealed unit designed for intermittent use and is self-priming.

### WHALE WATER PUMP

The Whale pump is a non self priming intermittently rated centrifugal pump which draws approximately two amperes from a 12V battery and therefore maximum continuous operation should not exceed 15 minutes.

The pump should not run without water and should not be used to pump water of a temperature above 60°C.

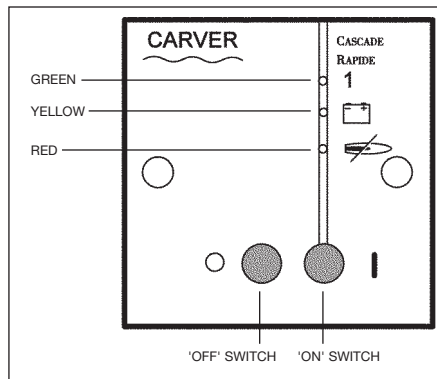

### CASCADE 2 GE WATER HEATER

#### OPERATING INSTRUCTIONS

**The Cascade Water Heater** must not be switched on until water flows from the hot water taps which indicates the water heater is full.

**The Cascade Water Heater** should not be used on BATTERY CHARGER ONLY (i.e. without a 12V battery in circuit) as this may cause the heater to operate incorrectly.

Under no circumstances connect **The Cascade Water Heater** directly to a mains water supply.

### TO OPERATE THE HEATER ON GAS

- CHECK** that the gas and 12V D.C. electrical supplies have been connected and turned on.
- SWITCH THE WATER HEATER ON** at the wall switch. The green light will come on and remain on.
- THE GREEN LIGHT** indicates that the heater is operating satisfactorily and does not refer directly to the burner operation.
- THE YELLOW AND GREEN LIGHTS** on together indicate that the voltage of the power supply to the heater is too low. The heater is automatically switched off until the voltage is high enough.
- THE RED AND GREEN LIGHTS** on together show that the burner has failed to light in the 10 second ignition period. This is usually due to failure of the gas supply or, in the case of a new installation, air in the gas pipes. Switch off and on again, which resets the controller and initiates a new ignition sequence. To clear air from the gas lines, several repetitions may be required.

## TO OPERATE THE HEATER ON MAINS ELECTRICITY

The immersion heater switch is located adjacent to the Cascade Water Heater switch.

With the caravan connected to site mains, electrical power may be used instead of gas to maintain a supply of hot water.

**For quick warm-up both gas and electrical supplies may be used, but for maintenance use only one or the other.**

The immersion heater takes approximately 2.75A when heating (fused at 3A) and this load must be taken into account if the site current supply is limited.

## CARVER P4 BLOWN AIR HEATING

Blown air heating is designed to give an efficient, quiet and comfortable source of heating which should give years of trouble free service.

### OPERATING THE HEATER

1. Ensure that the gas supply is turned on at the cylinder and that the 12V supply is connected.
2. Before using the heater, check that the openings for the products of combustion and combustion are not blocked. Ensure

that any snow is cleaned off the side of the vehicle on which the terminals are mounted.

3. At the wallswitch, repeatedly pressing the "I" button will select the various heater functions (fig 1) as follows:
4. By selecting "☼", no heat will be produced but the air delivery fan will run at speeds variable by the user adjusting the main knob, giving fresh air ventilation.
5. When low rate "↔", or high rate "↔" are selected, the heater will initially perform a short flue system prepurge followed by ignition and production of warm air.

The warm air delivery fan speed will automatically increase as the heater warms up, thereby avoiding initial strong currents of cold air.

6. When either of the heat settings is selected, the heater is thermostatically controlled to the required comfort level by a sensor inside the heater, sensing the air returned from the living space. This comfort level can be set as desired by turning the main knob on the wallswitch. A bright green light will indicate the selected option on the wallswitch. When, in the heat settings the light goes dim, this indicates that the burner is off on the thermostatic cycle.

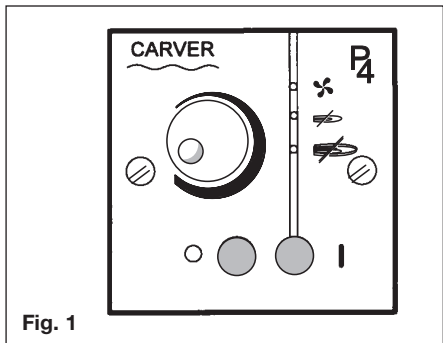

7. To turn the heater off, press the "O" button on the wallswitch.
8. A red light on the wallswitch indicates a fault condition.
9. It is strongly recommended that this heater, its supply, the ducts for the products of combustion and the combustion air supply, be inspected and serviced annually by a Carver approved dealer only. By law, this must be done every two years.

## Equipment Details

### REFRIGERATORS

Before using your refrigerator for the first time, it is advisable to wash the interior and its accessories.

When using the refrigerator on gas ensure that the gas isolation tap is fully open by turning the knob to the vertical position. The tap is located inside the sink unit at floor height. When travelling the fridge can only be operated in the 12V mode.

The current drain is approximately 9A and power is only available when the ignition circuit is switched on. On site, only the mains electric or gas modes should be used.

The refrigerator can run on either 240V, 12V or LP gas. Changing between these modes of operation is carried out by means of the controls on the control panel.

**Caution: Only use one source of energy at a time.**

After initial installation, servicing or changing gas cylinders etc., the gas lines may contain some air which should be allowed to escape by briefly turning on the refrigerator or other appliances. This will ensure that the flame lights immediately.

The flame failure device will automatically shut off the gas to the burner if the flame is blown out. On electric ignition versions, the

flame failure device will also shut off the gas if the burner does not re-light within about a minute of the flame being blown out.

#### MODEL RM4361

Two rocker switches are used to select the electric power supply, one for 240V (B) and one for 12V (A).

Refrigerator temperature is controlled by a thermostat knob (C) when the refrigerator runs on 240V.

The gas supply is turned on/off by means of the knob (D).

Refrigerator temperature is controlled by a thermostat (E) when the unit runs on LP gas. Please note that the thermostat has no OFF position.

The gas flame is electronically lit, monitored and relit if necessary. For this the toggle switch (F) should be ON during gas operation.

An indicator lamp in the switch flashes when the automatic igniter attempts to light the burner. Otherwise this lamp is OFF.

#### Gas Operation

1. Open the shut-off valve of the gas bottle (check that there is enough gas). Open any on-board shut-off valve.
2. Check that the switches for mains (B) and 12V (A) operation are OFF.

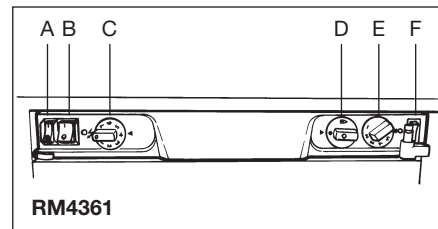

3. Turn on the gas supply by pressing knob (D) and turning it to the large flame position.
4. Set the thermostat knob (E) to the highest setting.
5. Throw on switch (F). A light in the switch should now start to flash, indicating that sparks are being generated at the burner.
6. Press button (D). This opens the flame failure device and allows gas to flow to the burner.
7. When the flame lights, the sparking stops automatically and the switch stops flashing.
8. Keep the button (D) pressed for a further 10–15 seconds to activate the flame failure device, then release it.

#### 240V Operation

1. Turn off the gas or 12V operation when applicable.

## Equipment Details

2. Turn knob (C) of the thermostat to its highest (coldest) position.
3. Set switch (B) to position I. The switch will light up green when the power supply is connected.

### 12V Operation

Only operate your refrigerator on 12V when the engine of the vehicle is running - otherwise your battery will soon become discharged.

1. If applicable, turn off the gas operation.
2. Set the 12V rocker switch (A) to I. The switch will light up red when the power supply is connected.

### WARNING:

When in transit, your refrigerator should be run on 12V and NOT on gas.

### Regulating the Temperature

It will take a few hours for the refrigerator to reach normal operating temperature, so it is suggested to start the refrigerator well in advance of a journey and, if possible, to store it with pre-cooled foodstuffs.

**On 240V operation** the refrigerator is controlled by a thermostat knob (C) and this should be set at 3–5. If a lower (colder) temperature is desired, set the thermostat to a higher figure.

**On 12V operation** the refrigerator works continuously.

**On LP gas operation** the refrigerator temperature is regulated by the gas thermostat (E) which should be set at 3–5. If a lower (colder) temperature is desired, set the thermostat to a higher figure.

**Caution: Only use one source of energy at a time.**

### MODEL RM4201

### LP Gas Operation

1. Open the shut-off valve of the gas bottle (check that there is enough gas). Open any on-board shut-off valve.
2. Check that the switches for mains (B) and 12V (A) operation are OFF.
3. Turn the gas control (D) to position 'max'.
4. Turn on the electric igniter (E). A ticking sound will be heard and a lamp in the switch will start flashing.
5. Depress the knob (D) of the flame failure device.
6. When the lamp stops flashing the flame is alight.
7. Keep the flame failure knob (D) depressed for a further 10–15 seconds.
8. Check that the flame remains alight by viewing through glass in the refrigerator.
9. To terminate gas operation, turn knob (D) to the OFF position. Set switch (E) to OFF.

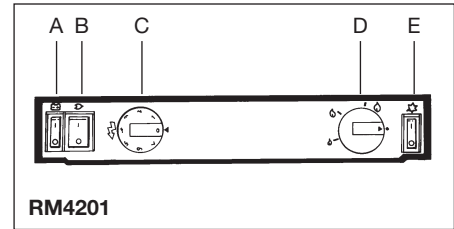

RM4201

### 240V Operation

1. Turn off gas or 12V operation when applicable.
2. Turn the knob (C) of the thermostat to its highest (coldest) position.
3. Set switch (B) to position I.

### 12V Operation

Only operate your refrigerator on 12V when the engine of the vehicle is running - otherwise your battery will soon be discharged.

1. If applicable, turn off the gas operation.
2. Set the 12V rocker switch (A) to I.

### Regulating the Temperature

It will take a few hours for the refrigerator to reach normal operating temperature, so it is suggested that the refrigerator be started well in advance of a journey and, if possible, to store it with pre-cooled foodstuffs.

## Equipment Details

**On 240V operation** the refrigerator is controlled by a thermostat knob (C) and this should be set at 3–5. If a lower (colder) temperature is desired, set the thermostat to a higher figure.

**On 12V operation** the refrigerator works continuously.

**LP gas operation** should always be initiated with the knob (D) at the 'max' position. Once the refrigerator is running, the temperature is controlled by turning the control knob between 'max', 'mid' and 'min' settings - 'max' being the coldest temperature.

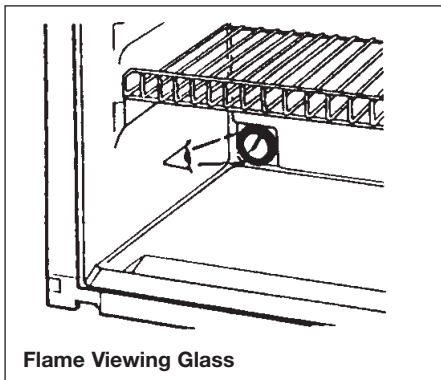

Flame Viewing Glass

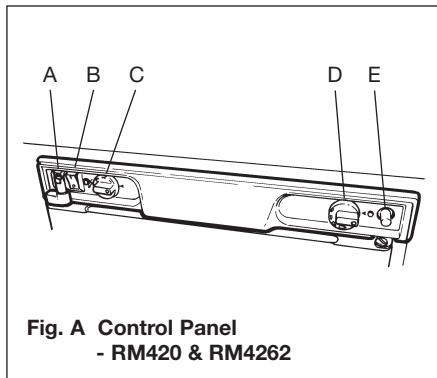

Fig. A Control Panel  
- RM420 & RM4262

### MODEL RM4200 & RM4262

#### Bottled Gas Operation - Lighting the burner

1. Open the shut-off valve of the gas bottle (check that there is enough gas). Open any on-board shut-off valve.
2. Check that the switches for mains and 12V are off.
3. Depress and turn on the gas control safety device knob (D) to the large flame symbol.
4. Depress the gas control safety device knob (D) and hold it down while depressing the piezo-electric igniter button (E) rapidly 3 or 4 times in quick succession.

5. Check the flame viewer (located bottom left of refrigerator) to see if the flame is alight.
6. Keep the safety device control knob depressed for a further 15–30 seconds.
7. Release the safety device control knob and again check to see that the flame is alight.
8. To terminate gas operation, turn knob (D) to '0'.

### ELECTRIC OPERATION

#### 240V Operation

1. Turn off gas or 12V operation when applicable.
2. Turn the knob (C) of the thermostat to its highest (coldest) position.
3. Set switch (B) to position I.

#### 12V Operation

There is no thermostat control on 12V operation.

**Only operate your refrigerator on 12V when the engine of your vehicle is running.**

**Note: Before operating the refrigerator on 12V it should be pre-cooled, together with its contents, by running it on bottled gas or 240V for a few hours before changing over to 12V and starting on a journey.**

## Equipment Details

1. If applicable, turn off the gas operation.
2. Set the 240V rocker switch (B) to 'O' and the 12V rocker switch (A) to 1.

### Regulating the temperature

Once the refrigerator has been started it will take a few hours to become cold.

**On 240V operation** the refrigerator is controlled by a thermostat and the thermostat knob (C) should be set at 3. If a colder temperature is required, set the thermostat to a higher number and vice versa.

**On LP gas operation** the refrigerator temperature is regulated by the gas control knob (D). If the ambient temperature is above 25°C and/or the door of the refrigerator is frequently opened, the knob should be set in the 'max' position. Below 25°C, the knob should be set at 'mid' and below 10°C at 'min' to avoid temperatures below freezing in the main compartment.

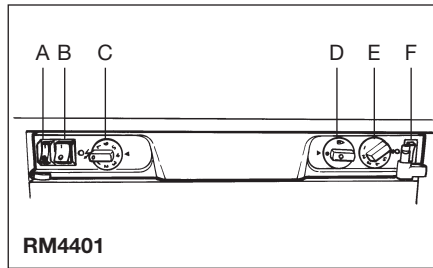

### MODEL RM4401

The refrigerator can be run on either 240V, 12V or LP gas. Changing between these modes of operation is carried out by means of the controls on the control panel.

Two rocker switches are used to select the electric power supply, one for 240V (B) and one for 12V (A).

Refrigerator temperature is controlled by a thermostat (C) when the unit runs on 240V. The gas supply is turned on/off by means of the knob (D). When lighting the gas press in the knob as explained further on.

Refrigerator temperature is controlled by a thermostat (E) when the refrigerator runs on LP gas. Please note that the thermostat has no OFF position.

### STARTING THE REFRIGERATOR

**Caution!**  
Only use one source of energy at a time.

#### LP Gas operation

After initial installation, servicing, or changing gas cylinders etc., the gas pipes may contain some air which should be allowed to escape by briefly turning on the refrigerator or other appliances. This will ensure that the flame lights immediately.

To start gas operation:

1. Open the shut-off valve of the gas bottle (check that there is enough gas). Open any on-board shut-off valve.
2. Check that the switches for mains and 12V operation are off.
3. Turn on the gas supply by pressing the (D) knob and turning it to the position. ⤴
4. Set the thermostat knob (E) to the highest setting.
5. Throw on switch (F). A light in the switch should now start to flash, indicating that sparks are being generated at the burner.
6. Press the (D) button. This opens the flame failure device and allows gas to flow to the burner.

## Equipment Details

- When the flame lights, the sparking stops automatically and the switch stops flashing.
- Keep the (D) button pressed for a further 10-15 seconds to activate the flame failure device, then release it. To terminate gas operation, turn knob (D) to "●" and (when applicable) set switch (F) to "0".

### 240V Operation

- Turn off gas or 12V operation when applicable.
- Turn the knob (C) of the thermostat to its highest (coldest) position.
- Set switch (B) to position 1. The switch will light up green when the power supply is connected.

### 12V Operation

Only operate your refrigerator on 12V when the engine of the vehicle is running - otherwise your battery will soon be discharged.

- If applicable, turn off the gas operation.
- Set the 12V rocker switch (A) to 1. The switch will light up red when the power supply is connected.

**Warning: You must run your refrigerator on 12V - and not on gas - when in transit.**

**WARNING: It is not allowed to have a naked flame at a fuel filling station.**

### REGULATING THE TEMPERATURE

The position number refers to fig. 3.

It will take a few hours for the refrigerator to reach normal operating temperature. We suggest you start it well in advance of a trip and, if possible, store it with precooled foodstuffs.

On 240V operation the refrigerator is controlled by a thermostat and the thermostat knob (C) should be set at 3-5. If a lower (colder) temperature is desired, set the thermostat to a higher figure.

On 12V operation the refrigerator works continuously.

On LP gas operation the refrigerator temperature is regulated by the gas thermostat (E), which should be set at 3-5. If a lower (colder) temperature is desired, set the thermostat to a higher figure.

### TRAVEL CATCH

Make sure that the travel catch is engaged when the motorhome is on the move, (fig. 1, Page 42).

The travel catch at the top of the door can be set in two different positions. In one position the door is held tightly shut. In the other position the door is secured ajar so that the refrigerator can be aired when not in use.

### WINTER OPERATION

Please check that the ventilation grilles or the flue outlet are not blocked by snow, leaves etc.

ELECTROLUX ventilation grilles can be fitted with winter covers, to protect the cooling unit against cold air. The covers may be fitted when the outside temperature is below approx. 10°C but should be fitted when the temperature is below the freezing point.

We suggest that you fit the winter covers when the vehicle is laid up during the winter months.

### MODEL RM4505

The model RM4505 is a 135 litre refrigerator with a separate 25 litre frozen food compartment.

This refrigerator is equipped with an Automatic Energy Selector (AES) which controls its operation and energy supply.

The system selects the available energy source in the order: 230-240V - 12V - LP gas.

No manual operation is necessary for selecting the energy source.

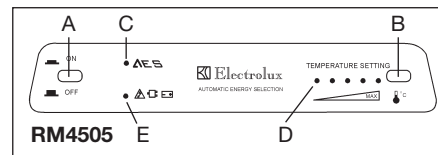

## OPERATING INSTRUCTIONS

The refrigerator is set into operation by pushing button (A) (main switch). The AES LED (C) lights green showing that the AES system is working. Push-button (B) is used for setting the electronic thermostat. The thermostat LEDs (D) show the chosen temperature position. When there is a demand for refrigeration, AES will connect the most favourable of the available energy sources.

**Note:** 12V must always be available to supply the electronics.

## STARTING THE REFRIGERATOR

### LP Gas Operation

AES will select LP gas operation under the following conditions:

- No AC (230-240V) available
- Engine not running (no high current at 12V DC available)
- AC available but too low
- Engine running but DC supply too low

(condition three and four are briefly described in item Undervoltage Operation over the page)

When the system chooses LP Gas operation, the flame failure device is automatically opened, allowing the gas to flow to the burner. At the same time, the electronic igniter is energised.

After initial installation, servicing, or changing gas cylinders etc., the gas pipes may contain some air which should be allowed to escape by briefly turning on the refrigerator or other appliances. This will ensure that the flame lights immediately.

If the flame goes out (by gust of wind etc.), the igniter is immediately activated and reignites the gas.

**Note:** The control electronics and the igniter must have a DC (battery) supply to operate.

### Gas trouble-shooting

If the AES LED (C) is flashing red, the system was not able to start or continue gas operation. Set the switch (A) to OFF and check that there is enough gas in the gas bottle, that its valve is open and that any valves in the gas line to the refrigerator are open.

Push button (A) to "ON" again. After 10 sec. AES will repeat the ignition sequence. If the AES LED (C) again starts flashing red after 30 sec., the problem persists (air in the line, no gas?). Switch (A) briefly off and then on again. It might be necessary to repeat this operation 2-3 times if the tubing contains air (after changing gas bottles, repairs etc.).

If this does not help, you should consult a service technician.

### 230-240V Operation

When a mains connection is available, AES will select this. Please note, that even being in AC mode, 12V DC is necessary for the internal supply of the electronics.

### 12V Operation

AES will select the 12V mode of operation only when the vehicle engine is running (detected by the alternator connection of the fridge D+).

### SWITCHING BETWEEN ENERGY SOURCES

When switching from one energy source to another, there are some delays implemented in the AES system. The 15 min. delay between switching off the engine and starting gas mode is intended to delay the starting of gas mode e.g. when stopping at a filling station.

**WARNING: It is not allowed to have a naked flame at a gas filling station. If you are not sure that your stop is shorter than 15 min., you are advised to switch off the main switch (A), when stopping at a filling station.**

# Equipment Details

## UNDERVOLTAGE OPERATION

The AES system is designed to guarantee the maximum cooling efficiency under any circumstance. The system continuously monitors the voltage level while in either 12V DC or 230-240V AC mode. If the voltage is too low, the system switches to gas mode shown by the yellow LED (E). The system stays in gas mode, until the electrical supply voltage has recovered to normal level.

## REGULATING THE TEMPERATURE

It will take a few hours for the refrigerator to reach normal operating temperature. So we suggest you start it well in advance of a trip and if possible store it with precooled foodstuffs.

The temperature of the refrigerator main compartment is set for all three sources of energy, by means of the thermostat knob (B). After turning on the refrigerator the system automatically chooses the mid-position. With some experience you will soon find a suitable setting. This does not normally need resetting as the same thermostat controls the main compartment temperature for all three sources of energy.

## TURNING OFF THE REFRIGERATOR

If the refrigerator is not to be used for some time:

1. Set the switch (A), to "OFF".
2. Shut off any on-board valve in the gas line to the refrigerator.
3. Empty the refrigerator. Defrost and clean it as described earlier. Leave the doors of the refrigerator and frozen food compartment ajar.
4. When the vehicle is laid up for a long period of time (e.g. during the winter months), we suggest fitting the winter covers on to the grills.

## IF THE REFRIGERATOR FAILS TO WORK

Check the following points before calling a service technician:

1. That the green AES LED goes on when the switch (A) is set to "ON" (12V must be available).
2. When mains are connected but the refrigerator stays in gas operation check the refrigerator is correctly connected and the fuse (230-240 V) is intact.
3. Is the 12V fuse intact?
4. **Disconnect the wall plug, and the 12V wires before servicing.** Check the fuses on the circuit board, (under the black cover at the top of the refrigerator and

behind the control panel).

Remove the two screws holding the control panel, pull out the control panel with its electronics. Remove the cover and check the fuses.

5. In transit, if the refrigerator does not operate in DC mode check the alternator (D+) is correctly connected.
6. If the AES LED (C) flashes red, see chapter **Gas trouble-shooting**.

### **If the refrigerator is not cold enough it may be because:**

1. The ventilation is inadequate owing to reduced area of the ventilation passages (partial blockage of grilles from wire mesh etc.).
2. The evaporator is frosted up.
3. The temperature control setting is incorrect.
4. The gas pressure is incorrect - check the pressure regulator at the gas container.
5. The ambient temperature is too high.
6. Too much food is loaded at one time.
7. The door is not properly closed or the magnetic sealing strip is defective.

### **If the refrigerator still does not work properly, call a service technician.**

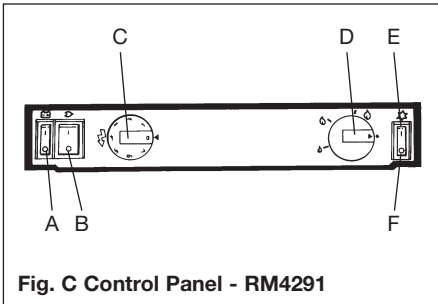

**Fig. C Control Panel - RM4291**

### MODEL RM4291 (86 litres)

Two rocker switches are used to select the electric power supply, one for 12V (A) and one for 240V (B) (see Fig. C).

Refrigerator temperature is controlled by a thermostat knob (C) when the refrigerator runs on 240V.

The refrigerator runs continuously on 12V operation (no thermostat).

The gas supply is turned ON/OFF by means of the knob (D). When lighting the gas, the knob must be pressed as explained in LP Gas Operation.

Refrigerator temperature is controlled by a thermostat (D) when the refrigerator runs on LP gas.

The gas flame is electronically lit, monitored and re-lit if necessary. For this, the toggle switch (E) should be 'ON' during gas operation.

The RM4291 is fitted with an internal light which is operated by the door.

### STARTING THE REFRIGERATOR

#### LP Gas Operation

Before you start gas operation:

1. Open the shut-off valve of the gas bottle (check that there is enough gas). Open any on-board shut-off valve.
2. Check that the switches for mains and 12V operation are OFF.
3. Turn on gas supply by pressing knob (D) and turning it to the highest flame position.
4. Press ON switch (E). A light in the switch should now start to flash, indicating that sparks are being generated at the burner.
5. When the flame ignites, the sparking stops automatically and the switch stops flashing.
6. Keep the knob (D) pressed for a further 10 to 15 seconds to activate the flame failure device, then release it.
7. To terminate gas operation turn knob (D) to the '•' position and put switch (E) to the OFF position.

#### 240V Operation

1. Turn off gas or 12V operation when applicable.
2. Turn the knob (C) of the thermostat to its highest (coldest) position.
3. Set switch (B) to position I. The switch will light up green when the power supply is connected.

#### 12V Operation

Only operate your refrigerator on 12V when the engine of your vehicle is running. Install through a relay, otherwise your battery will soon be discharged.

**Note:** Before operating the refrigerator on 12V, it should be pre-cooled, together with its contents, by running it on bottled gas or 240V for a few hours before changing over to 12V and starting on a journey.

1. If applicable turn off the gas operation.
2. Set the 12V rocker switch (A) to I. The switch will light up red when the power supply is connected.

### REGULATING THE TEMPERATURE

The position numbers refer to Fig. A.

Once the refrigerator has been started it will take a few hours to become cold.

On 240V operation the refrigerator is controlled by a thermostat and the thermostat knob (C) should be set at 3-5.

## Equipment Details

If a lower (colder) temperature is desired, set the thermostat to a higher figure.

On LP gas operation the refrigerator temperature is regulated by the gas thermostat knob (D), which should be set at the medium 'flame' position. If a lower (colder) temperature is desired, set the thermostat to the larger 'flame' position.

On 12V operation the refrigerator works continuously.

### WINTER OPERATION - ALL MODELS

Please check that the ventilation grilles or the flue outlet are not blocked by snow, leaves, etc.

Electrolux ventilation grilles can be fitted with winter covers to protect the cooling unit against cold air. The covers may be fitted when the outside temperature is below approx. 10°C but should be fitted when the temperature is below freezing point.

It is suggested that winter covers are fitted when the motorhome is laid up during the winter months.

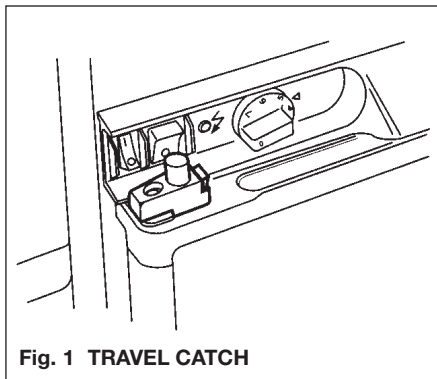

Fig. 1 TRAVEL CATCH

### TRAVEL CATCH

All models are fitted with a travel catch (see above) to keep the refrigerator door securely closed when the vehicle is on the move. Remember always to push the catch down so that its lower end fully engages the plastic bush in the top of the door, before moving off.

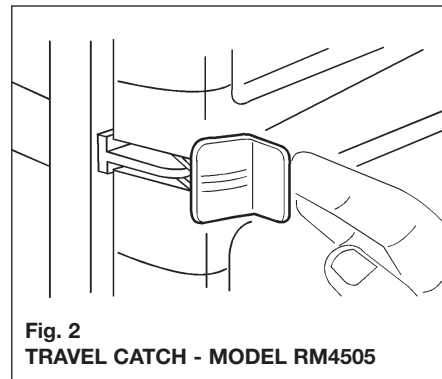
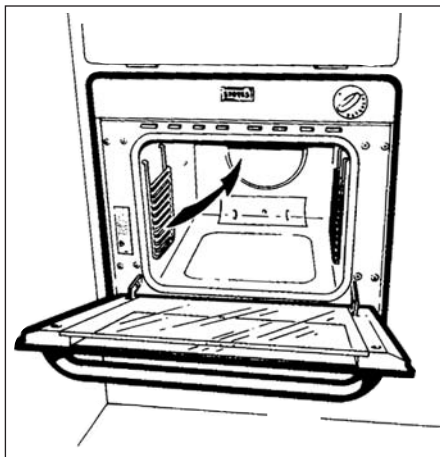

Fig. 2  
TRAVEL CATCH - MODEL RM4505

### TRAVEL CATCH - MODEL RM4505 ONLY

The refrigerator is equipped with two travel catches. Make sure that both are engaged when the motorhome is on the move.



### STOVES COMBINATION OVEN

#### IGNITION

**IMPORTANT:** A safety device stops the ignition being used when the oven door is closed.

1. Open the oven door and turn the control knob anti-clockwise to the required gas mark. Push in and hold in the control knob and press the ignition button on the left hand side of the fascia.
2. Once the burner has lit, close the oven door.

3. If the flame goes out, the Flame Failure Device cuts off the gas supply to the burner. To light the oven again, repeat the ignition procedure.
4. To turn off - push in the control knob and turn clockwise.

#### Note:

- Keep young children away from the vicinity of the oven.
- DO NOT use foil on the oven shelves as this creates a fire hazard.
- Keep all flammable materials away from the oven.

#### Caution:

Care must be taken in rear end kitchen layouts - when the oven is in use DO NOT leave the shower room door open against the oven as heat damage could occur.

#### CLEANING

All parts of the oven can be safely cleaned with a cloth wrung out in hot soapy water.

To avoid damaging the surfaces when removing stubborn marks, we recommend the following:

#### Glass Parts

Use a mild cream cleanser, rinse thoroughly and dry with a soft cloth. DO NOT use abrasive cleaners.

The inner door can be removed for cleaning. Open the door wide, hold the bottom and top edges and slide out. When replacing the glass panel, hold it level and straight with the grooves in the door trims before sliding back in.

#### Painted Parts

Only use a clean cloth wrung out in hot soapy water.

#### Vitreous Enamel Parts

Use a mild cream cleanser.

#### Chrome Plated Parts

DO NOT use abrasives or polishes. Use a mild cream cleaner.

Shelf runners can be removed for cleaning:

1. Pull the bottom edge away from the side of the compartment.
2. Disengage the runners from the hanging holes.

**Warning: Caustic pastes, abrasive cleaning powders, coarse wire wool and hard implements will damage the surfaces.**

## Equipment Details

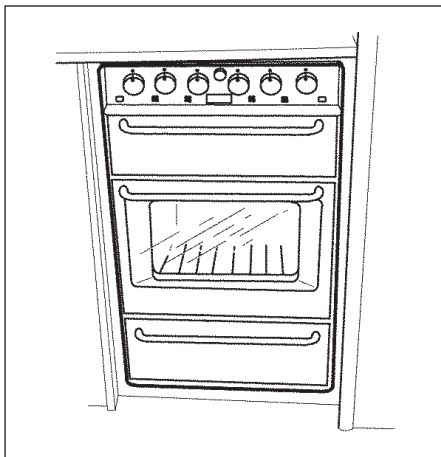

### STOVES 8000/9000 COOKER

#### THE OVEN

Important: A safety device stops the ignition being used when the oven door is closed.

#### To light the oven

1. Open the oven door and turn the control knob anticlockwise to the required gas mark. Push in and hold in the control knob, and either press the ignition button or hold a match to the burner.
2. Once the burner has lit, close the oven door and hold the knob in for 15–20 seconds.

3. If the flame goes out, the flame sensing device cuts off the gas supply to the burner. To light the oven again, wait for 3 minutes and repeat the ignition procedure.

#### To turn off the oven

Push in the control knob and turn clockwise.

#### Note:

A 15 minute warm-up time is recommended before using the oven.

Keep young children away from the vicinity of the oven.

DO NOT use foil on the oven shelves as this creates a fire hazard.

Keep all flammable materials away from the oven.

#### CLEANING

All parts of the oven can be safely cleaned with a cloth wrung out in hot soapy water.

To avoid damaging the surfaces when removing stubborn marks, we recommend the following:

#### Glass Parts

Use a mild cream cleaner, rinse thoroughly and dry with a soft cloth. DO NOT use abrasive cleaners.

The inner door glass panel can be removed for cleaning. Open the door wide, hold the bottom and top edges and slide out. When replacing the glass panel, hold it level and

straight with the grooves in the door trims before sliding back in.

#### Painted Parts

Only use a clean cloth wrung out in hot soapy water.

#### Vitreous Enamel Parts

Use a mild cream cleaner.

#### Chrome Plated Parts

DO NOT use abrasives or polishes. Use a mild cream cleaner.

Shelf runners can be removed for cleaning.

1. Pull the bottom edge away from the side of the compartment.
2. Disengage the runners from the hanging holes.

**Warning: Caustic pastes, abrasive cleaning powders, coarse wire wool and hard implements will damage the surfaces.**

## Equipment Details

### THE HOB

#### Ignition

1. Push in the control knob and turn anti-clockwise to the large flame symbol.
2. Keep the knob depressed and press the ignition button (if fitted), or hold a lighted match or taper to the burner.

Keep the control knob depressed for 15-20 seconds before releasing.

**Note:** The FFD (Flame Failure Device) will cut off the gas supply if the flame goes out for any reason.

3. Turn the control knob to the required setting.
- Do not use foil on the hob as it creates a fire hazard.
  - Glass lids may shatter when heated. Turn off all burners before shutting the lid.

Always use the most appropriate size of burner for the pan you wish to use. Use pans with a flat base of minimum 100mm/4in diameter and maximum 200mm/8in diameter, which are stable in use. Avoid odd or mishapen pans as these may cause instability.

**Warning: All pans should be mounted centrally over the burners, even when cooling, to protect adjacent walls.**

**Do not lower hob cover until hobs have cooled.**

**On no account should this appliance be used as a space heater.**

### THE GRILL

**Note:** The door must be open when the grill is in use.

**Caution:** When the grill is being used, accessible parts may be hot; young children should be kept away.

- Never cover the grill pan or grid with cooking foil, or allow fat to build up in the grill pan as this creates a fire hazard.
- Keep all flammable material away from the appliance.

#### To light the grill

Push in the control knob and turn anti-clockwise to the large flame symbol. Keep the knob depressed, and press the ignition button (if fitted), or hold a lighted taper to the burner. The knob must be held in for 15–20 seconds before releasing.

### Using the grill

Push in the grill pan until it locates centrally under the grill burner. There are 3 different grilling positions as the trivet can be inverted to give a high or low position or it may be removed.

1. The high trivet position is suitable for toasting bread.
2. The low trivet position is suitable for grilling all types of meat.
3. With the trivet removed the food is placed directly on the base of the grill pan, e.g. when cooking dishes such as whole fish.

Always pre-heat the grill for 3 minutes for best results.

When you have finished grilling, check the control knob is in the OFF position.

**Warning: When cooking it is essential to provide additional ventilation such as opening windows near the grill, cooker and oven.**

## Equipment Details

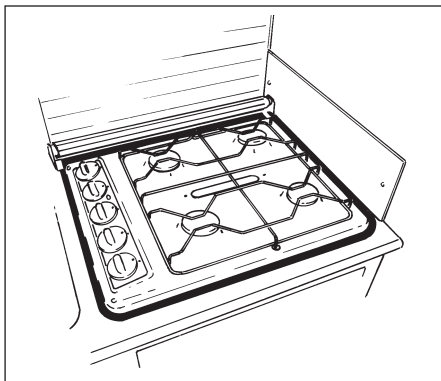

### STOVES VANETTE HOB & GRILL

#### THE HOB

##### Ignition

1. Push in the control knob and turn anti-clockwise to the small flame symbol.
2. Keep the knob depressed and press the ignition button (if fitted) or hold a lighted match or taper to the burner.

Keep the control knob depressed for a few seconds after the burner has lit until the flame is established and the FFD has opened.

**Note:** The FFD (Flame Failure Device) will cut off the gas supply if the flame goes out for any reason.

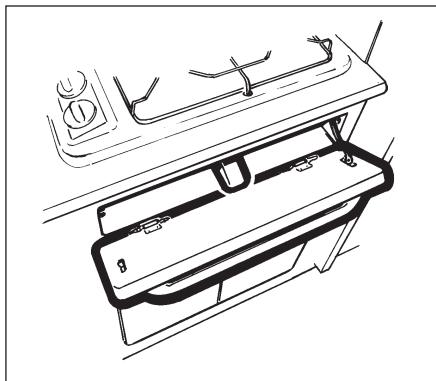

3. Turn the control knob to the required setting.

##### To Turn Off

Turn the control knob clockwise until the dot symbol • on the control knob is next to the reference mark on the fascia.

**Note:** If the ignition uses a 1.5V battery and the burners fail to light, renew the battery (Size AA Type HP7 or IR6).

The burners at the rear of the hob can be used for boiling or deep fat frying while the front burners are suitable for items that will need attention.

##### Pan Sizes

Do not use pans with a base diameter

greater than 228mm (9"). Using a pan that is larger than this may cause damage to the control knobs.

#### THE GRILL

The operation of lighting and controlling the grill is the same as for the hob.

If a door is fitted to the grill it **MUST** be kept **OPEN** while the grill is in use.

There are three different grilling positions as the trivet, inside the grill pan, can be inverted to give a high or low position or it may be removed.

**DO NOT** use foil on the grill pan as it creates a fire hazard.

#### Caution:

Accessible parts may become hot when the grill is in use; young children should be kept away.

## Equipment Details

### CRAMER HOB

Please read these operating instructions carefully before using the appliance

#### Validity

These operating instructions apply to the following Cramer Built-in-Cookers in the EK 2000 model range:

EK-1101 to EK-1277, CE-1300 to CE-1414

#### Initial Operation of the Appliance

1. Open the gas-bottle valve.
2. Open the cooker shut-off valve.
3. Turn the control knob of the relevant burner from the off-position (0-mark), anticlockwise to maximum (high flame).
4. Push the knob in and hold it in this position.
5. Ignite the burner with a match or other suitable ignition device.
6. If the burner ignites, the knob can be released after approximately 10 seconds.
7. The knob may now be set to the required burner position:

High flame = maximum position  
(depending from model: 2.0kW, 1.6kW or 1.0kW)

Low flame = minimum position  
(ca. 0.5kW)

8. The entire ignition process should be clearly visible from above and not obstructed by cooking utensils.

#### Switching off the Appliance

1. Turn the control knob to the off-position (0-mark) to extinguish the burner.
2. Close the cooker shut-off valve.
3. Close the bottle valve during longer periods of non-operation.

#### Action in case of Faults

1. If a fault occurs the appliance must be switched off (see above) and a specialist consulted.

#### Correct Use of the Cooker

##### Saucepans

1. Care should be taken that saucepans are placed in the middle of the ring and that flames do not rise above the rims.
2. Pans with misshapen/distorted bottoms must not be used.

##### Air supply

1. Ventilation openings with a cross section of at least  $150\text{cm}^2$  are essential in the room where the cooker is operated during use of the burner(s). (See instructions displayed above the cooker).
2. The combustion air supply pipes should be checked from time to time and cleaned if necessary.

3. The burners must not be used as heaters.

**WARNING: The burners must not be operated during refuelling or in garages.**

#### Instructions for Long Periods of Non-Operation

1. Turn the knobs to the off-position (0-mark).
2. Close the cooker shut-off valve.
3. Close the bottle valve.
4. After a long period of non-operation the appliance should be examined by a specialist\*.

#### Care and Cleaning of the Appliance

1. A standard cleansing agent can be used to clean the appliance.
2. Allow the appliance to cool down before cleaning.
3. To avoid damage, the outer surface of the appliance should be cleaned using only a damp cloth without the addition of chemical or granular cleansing agents.
4. The burner head(s) must not be dismantled when cleaning the appliance.
5. Care must be taken that cleanser does not spill into the burner(s).
6. After longer journeys the appliance should be examined for any obvious damage or loose parts.

## Equipment Details

### Maintenance

1. For safety reasons it is essential that the appliance be examined annually by a specialist\* for fault-free operation and any faults eliminated.
2. The following functions, in particular, should be checked during the annual service:
  - a. Inspection of gas density.
  - b. Inspection of burner safety and flame stability.
  - c. Inspection of fresh air supply.
  - d. Inspection of the safety and control fittings (burner taps).
3. During each service the cooker box should be examined in correlation with the appliance and should be checked against the relevant regulations.
4. If the flame openings of the burner heads become dirty or blocked, they must be cleaned.
5. The thermo-couple must be kept cleaned and the correct distance between the burner head and the thermo-element maintained (ca 2-4mm).
6. The liquid gas supply system of appliances used in motorised vehicles should be tested by a specialist\*, before initial operation and every two years

thereafter, for tightness and function.

A test conformance certificate should be issued by the specialist\*. It is the user's responsibility to arrange these tests.

7. Pressure loss should be checked during the test.

### General Safety Advice

1. If the smell of gas is detected:
  - a. Close the bottle valve and leave it closed until the fault is repaired.
  - b. Open all windows and leave the room.
  - c. Do not turn on any electrical equipment and avoid the use of naked flame, which could ignite the gas.
  - d. Consult a specialist\*.
  - e. Under no circumstances attempt to find the leak with the aid of a naked flame.
2. Any alteration to the appliance could be dangerous and is not permitted.
3. Some parts of the appliance become very hot during use; keep children away.

\*Specialists

Expert gas specialists are those specialists whose training, knowledge and practical experience guarantee that they will carry out the inspection correctly.

## THETFORD CASSETTE C-200

### FEATURES

1. Removable seat and cover.
2. Rotatable bowl.
3. Valve blade handle: opens and closes valve blade manually.
4. Flush button: activates flush.
5. **Only Cassette C-200S E/C-200 CE:**  
Valve blade button: opens and closes valve blade electronically.
6. Waste-level warning device: indicates when holding tank requires emptying.
7. Rotating pour-out spout: makes emptying holding tank easy and convenient.
8. Upper carrying handles.
9. Automatic holding tank vent: vents the holding tank when there is over pressure if holding tank is inserted into the toilet.
10. Valve blade opener.
11. Sliding cover: closes automatically when holding tank is taken out. Guarantees optimum hygiene.
12. Valve blade.
13. Press button valve: allows air in to avoid splashing while emptying.
14. Hand grip.
15. Access door (outside caravan).

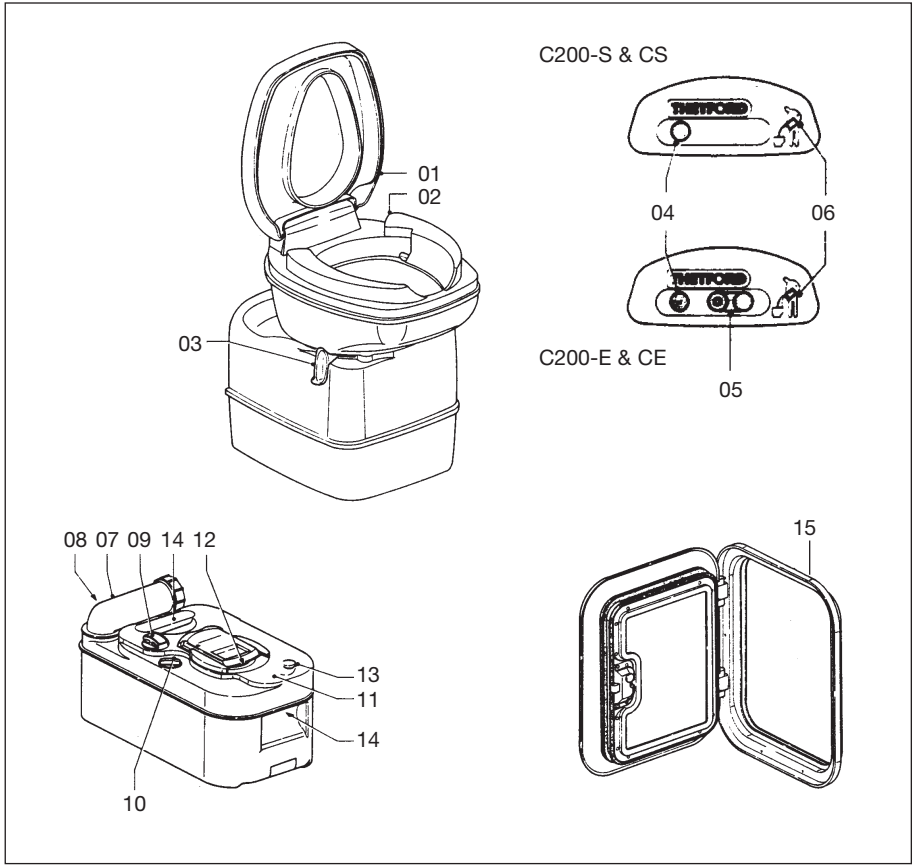

## Equipment Details

### Cassette C-200 S and C-200 CS

The toilet section of the C-200 S/C-200 SC includes a rotatable bowl, a removable seat, a control unit with a flush button and a waste level warning device. Under the bowl, the valve blade handle is located.

#### Preparing for Use

1. To remove holding tank, open the access door. Pull retaining clip upwards (fig. 1).
2. Remove holding tank by pulling straight out. When holding tank hits the stop, tilt downwards slightly and remove (fig. 2).
3. Position tank vertically and swivel pour-out spout upwards (fig. 3).
4. Remove the cap of pour-out spout. Add required amount of toilet fluid through pour-out spout. Add small amount of water through spout to cover holding tank bottom. Replace cap and return pour-out spout to its original stored position (fig. 4).

**Note: Hotter weather or longer retention time may require additional toilet fluid. Use only Thetford toilet fluid to achieve the best results.**

**Caution: Never add toilet fluid directly into toilet bowl.**

5. Slide the holding tank into the vehicle through access door (fig. 5).
6. Make sure the holding tank is secured by the retaining clip. Close and lock access door (fig. 6).

#### Operation

7. Turn the bowl in the most comfortable position, when necessary (fig. 7).
8. Before using the toilet we recommend adding some water to the bowl by pressing the flush button. Flush will stop when the button is released (fig. 8).

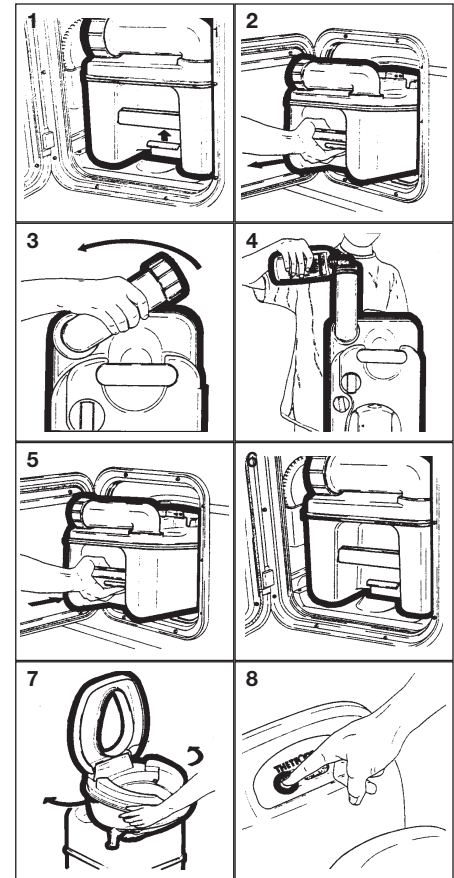

## Equipment Details

9. To open the blade turn the blade handle anti-clockwise (fig. 9).
10. To flush, press the flush button (fig. 10). After flushing, close the blade by turning the blade handle clockwise. The toilet may also be used with the valve blade open, which allows waste to pass directly into the holding tank.

### CASSETTE C-200 E and C-200 CE

11. To open the blade, push on the left side of the blade opener button (fig. 11). Blade can also be opened by turning the blade handle anti-clockwise (fig. 9a).
12. To flush, press the flush button (fig. 10). After flushing, close the blade by pushing the right side of the blade opener button (fig. 12).

The blade can also be closed by turning the blade handle clockwise.

The toilet can also be used with the valve blade open, which allows waste to pass directly into the holding tank.

### Emptying the Cassette

The holding tank capacity is approximately 17 litres and the tank should be emptied when waste-level warning device comes on. The waste-level warning device will come on when tank contains more than 15 litres of

waste. From that moment there is approximately 2 litres capacity left. This is equal to approximately 5 uses.

**CAUTION: Do not allow cassette to become overfilled. See trouble shooting section for emergency emptying procedure.**

13. Open access door and remove holding tank. Holding tank can only be removed when valve blade is closed (fig. 13).
14. Carry the holding tank, pour out spout up, to a normal household type toilet or other authorised disposal point. Set the holding tank in vertical position and rotate pour-out spout upwards (fig. 14).
15. Remove spout cap. Grasp unit by upper carrying handle nearest to pour-out spout. Place other hand on upper rear hand grip so that air relief valve button can be depressed with the thumb while emptying. This ensures smooth outflow of tank contents (fig. 15).

**Note:** Depress air relief valve button only when pour-out spout is pointed downwards.

Rinse the holding tank with clear water. For preparing for use again, see steps 1 to 6.

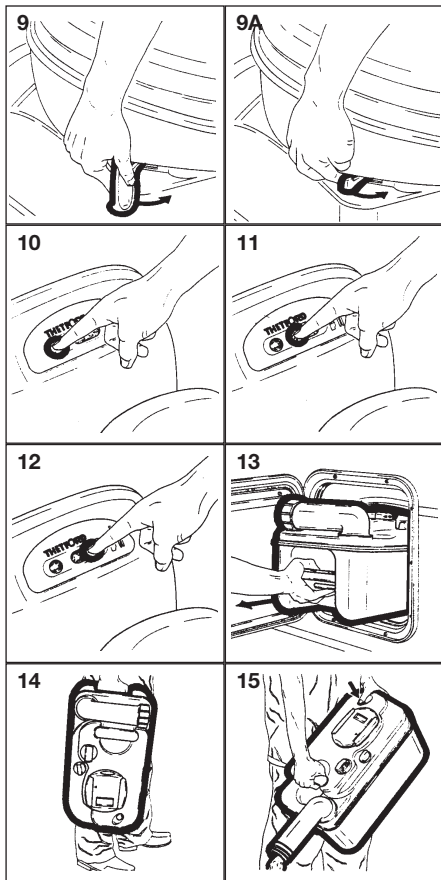

## Equipment Details

### THETFORD CASSETTE PORTA POTTI TOILET

The Cassette Porta Potti is constructed of high quality plastics for durability and has a high gloss finish that is easy to clean and maintain. The unit consists of two sections; a permanently installed toilet system and a slide out waste holding tank – CASSETTE.

The toilet section includes a seat and cover, flush and valve blade opener knob, toilet tissue compartment and holder, waste level indicator, built-in toilet fluid storage compartment, a drip tray – a drain tube assembly and a fresh water tank.

The unique cassette section is located underneath the toilet and is removed for emptying from outside the motorhome through an access door. A rotating pour-out spout, automatic holding tank vent, air release valve, valve blade, carrying handles and hand grips are incorporated into the cassette.

#### PREPARING FOR USE

1. Open access door on the side of the motorhome and swing out fresh water fill funnel.
2. Fill freshwater tank using a hose or jerrycan until water funnel level reaches neck. Tank capacity is 15 litres. Aqua Rinse may be added to improve cleaning of bowl and flushing of unit.

3. Replace cap. Swing water fill funnel inward until it touches side of water tank.  
**Note:** 150ml of water will remain in fill bottle when fresh water tank is empty.

4. Next add Aqua Kem to cassette for controlling odours. Depress retaining clip.
5. Remove cassette by pulling straight out. When cassette hits stop, tilt downward slightly and remove (stop for safety when cassette is full).
6. Position tank vertical and swivel pour out spout upward.

7. Remove cap. Remove deodorant from storage compartment. Add 100ml of Aqua Kem or 120ml of Aqua Kem Bio through pour out spout. Add small amount of water through spout to cover tank bottom. Replace cap and return pour out spout to its original stored position.

**Note:** As an alternative, deodorant can be added to cassette through the valve blade opening. Hotter weather or longer retention time may require the addition of more Aqua Kem.

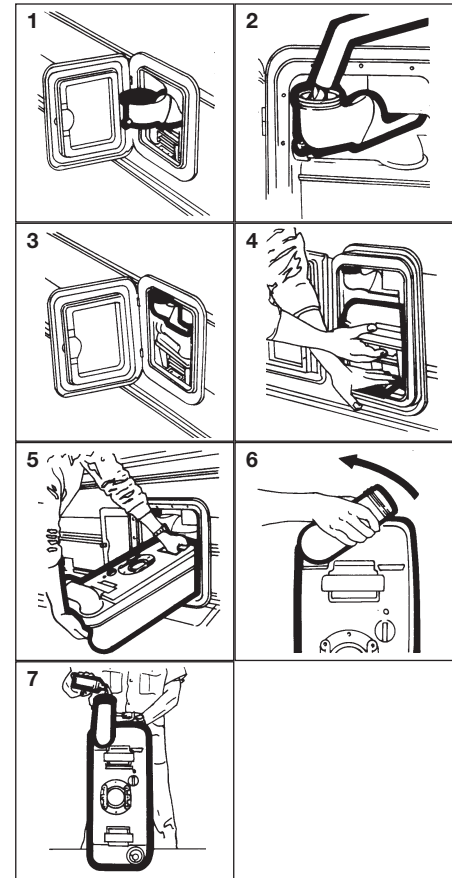

# Equipment Details

**CAUTION:** Do not add Aqua Kem Concentrate or Aqua Kem Bio directly into toilet bowl while cassette tank valve blade is closed. Pressure, due to heat and altitude change, can build up in the cassette tank causing bowl contents to splash upward upon opening the valve blade if opened too fast. Before each use, open and shut the cassette valve blade to vent the tank.

- Slide the cassette, pour out spout facing outside, into the motorhome through access door. Never force insertion or removal of the cassette tank as damage to the system can occur.
- Make sure the cassette is secured by the retaining clip. Close and lock access door.

**OPERATION**

**Flushing (Electric Models)**

- Before using the toilet we advise adding some water to the bowl by pressing down the flush knob. This avoids marking the bowl. Water will stop flowing when knob is released.
- To flush after use, press the flush knob down while turning in an anti-clockwise direction. The turning motion opens the valve blade, emptying the toilet bowl.

This procedure results in the best bowl rinse and most efficient use of water. After flushing, turn the knob in a clockwise direction to close valve blade. The toilet can also be used with the valve blade open, which allows waste to go directly into the holding tank.

**Flushing (Manual Models)**

- Before using the toilet, we advise adding some water to the bowl by turning the flush knob in a clockwise direction. When flush knob is released it will turn automatically back.
- To flush after use, turn the valve knob in an anti-clockwise direction and turn the flush knob. This procedure results in the best bowl rinse and most efficient use of water.

**TOILET TISSUE (Electric Models)**

- Toilet tissue is stored in the specially designed storage compartment that helps keep tissue clean and dry. Tissue can also be suspended on a tissue holder using the special wall bracket, if desired.

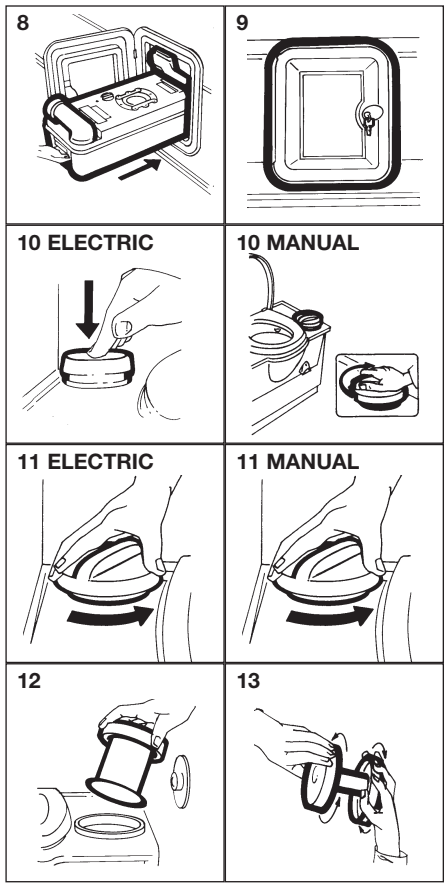

## Equipment Details

- To replace tissue, remove tissue holder from compartment by pulling up on tissue cover. Hold bottom of tissue holder in one hand and cover in the other and turn in opposite directions until you hear a click. Pull apart. Place tissue on holder, insert prongs of cover into holder. Hold cover and holder and twist in opposite directions until locked. Aqua Soft toilet tissue is recommended for best results.

### EMPTYING THE CASSETTE

The cassette capacity is 20 litres and should be emptied when the waste level gauge indicator goes from green to full red. The gauge does not begin to move from green to red until the tank is over half full.

**Caution:** Do not allow cassette to become overfilled.

The holding tank features a unique sliding cover (1) which guarantees optimal hygiene. The sliding cover moves automatically when the holding tank is inserted. When holding tank is removed, the cover automatically assumes its correct position. To clean the holding tank, you may remove the cover manually by sliding it towards the pour-out spout.

To empty cassette make sure that the valve blade is in the closed position.

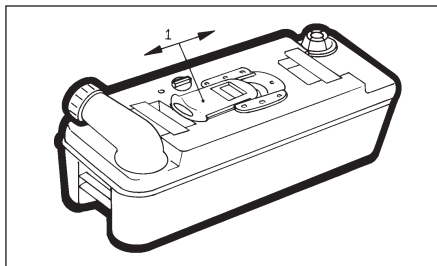

- Open the access door on side of motorhome. Depress the retainer clip, pull cassette until stop, tilt and remove cassette.
- Carry the cassette using the lower carrying handle (pour out spout up) to a normal household type toilet or other authorised disposal point. Set cassette in vertical position on the ground and rotate pour out spout upward.
- Remove spout cap. Grasp unit by upper carrying handle nearest to pour out spout. Place other hand on upper rear grip so that the air relief valve button can be depressed with thumb while emptying, to ensure smooth outflow of tank contents. When empty, rinse tank and valve blade with water.

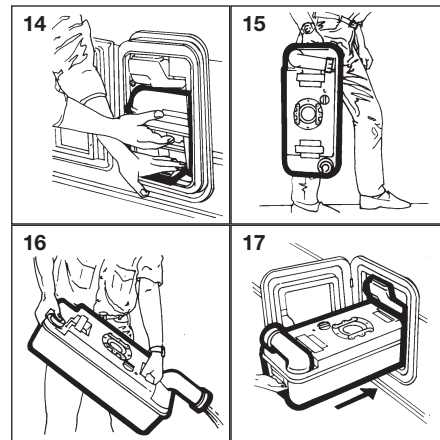

**Note:** Depress air release valve button only when pour out spout is pointed downwards.

- After preparing for use, slide the cassette into the caravan. Check to make sure that the retaining clip secures the tank in a locked position. The pour out spout end of the tank should be visible through the access door opening. Add water to the fresh water tank as outlined in "Preparing for Use" section. Close and lock access door.

## CLEANING AND MAINTENANCE

No routine maintenance is required on the Thetford Cassette Porta Potti. The use of Aqua Rinse helps to clean and protect the toilet bowl, valve blade and seals during flushing. Do not use strong household detergents or cleaners with chlorine, solvents or acid contents, as they will damage valve seals.

Empty cassette and rinse tank with clear water. Use a mild soap to clean toilet bowl, seat and cover, as well as exterior of toilet unit and cassette. Replace tank inside motorhome.

**Note:** Pour-out spout and vent plug can be removed. Seals should be greased if necessary with acid-free vaseline.

## WINTERING/STORAGE

The Thetford Cassette Porta Potti is easily winterised for storage or cold weather use.

18. Empty the fresh water tank using the drain tube. Pull drain tube down and outward through door opening to drain water from tank. In the case of the manual flush, turn the flush knob a few times to drain the pump assembly.
19. Empty the water fill funnel by pulling the bottle away from tank. Remove small water cap at fill bottom, allowing water to drain from water funnel.

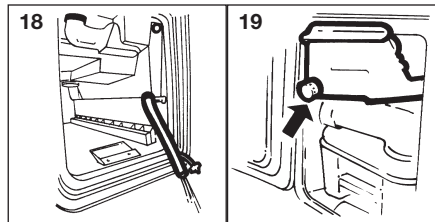

**Note:** Do not tighten caps, this helps in keeping unit dry.

## COLD WEATHER USE

To prevent freezing during cold weather use, add anti freeze to the fresh water tank. Use a non-toxic (propylen-glycol) type of anti freeze. Refer to chart on container to obtain level of protection.

## HIGH ALTITUDE AND HOT WEATHER USE

With large temperature differences and changing heights during driving, overpressure can start to build up in the holding tank. To depressurise your tank continuously, we recommend to keep the flush knob about 10 degrees in the direction of the arrow.

## THETFORD WARRANTY

1. The Thetford Cassette Porta Potti is warranted for one year from the date of purchase, provided the warranty card has been completed and returned to Swift within 30 days after the date of purchase.
2. The warranty covers replacement of parts arising from defects and workmanship and from the inability of the unit to perform its intended function.
3. In case of a defect apply to original dealer with proof of purchase.
4. Defects, which in our judgement occurred from misuse, negligence or accident, are not covered by the warranty. In addition, the warranty does not apply if the product is; installed or handled improperly, other than the prescribed chemical agents have been used, the product has been altered in any way or has been repaired by unqualified persons, or if the serial number and/or date has been altered or removed.
5. Should the original buyer wish to return to us parts believed to be defective, the parts should be sent prepaid. If we find the parts defective and covered by warranty, they will be repaired and returned. If warranty does not apply or has expired, a nominal charge will be made. Any transport costs are for the account of the owner.

## Equipment Details

- Before returning product or parts, they should be cleaned in order to carry out inspection and repair.
- No other warranty is given and no personal representative is authorised to make any warranty or assume liability by words or action under any warranty other than that is contained herein. This warranty is expressly in lieu of any other expressed or implied warranty of whatever nature and expressly excludes any other or further liability.

### HEATING

#### TRUMATIC C 3400/C 6000 OPERATING INSTRUCTIONS

**Attention: If the heater is not being used, always drain the water contents if there is a risk of frost. There shall be no claims under guarantee for damage caused by frost!**

#### FUNCTION DESCRIPTION

The Trumatic C heater is operated with a burner with fan assistance.

In **winter operation** the appliance automatically selects the most favourable burner level corresponding to the temperature difference between the temperature setting and the actual room temperature. Model C 6000 has three power levels (2000, 4000 and 6000 W).

Model C 3400 has two power levels (2000, 3400 W) Water filled in the storage water heater is automatically heated as well.

In **summer operation** the water is heated at the lowest burner level. When the water temperature of 60° or 40° is reached the burner switches off and the yellow indicator lamp goes out.

**In the standard models operation is also possible without water contents. In the special version with electric heating 230 V the appliance is only to be operated in the “Summer operation” with water (this applies to both gas and electrical operation).**

If only the cold water system is being operated, without using the water heater, the heater tank also fills up with water. **In order to avoid damage by frost, the water contents must be drained by operating the safety/drain valve**, also when the water heater has not been used. As an alternative, a shut-off valve (resistant to hot water) can be installed upstream of the cold and hot water connection.

**Attention:** The water tank lining is food proof. However, we do not recommend using the water as drinking water!

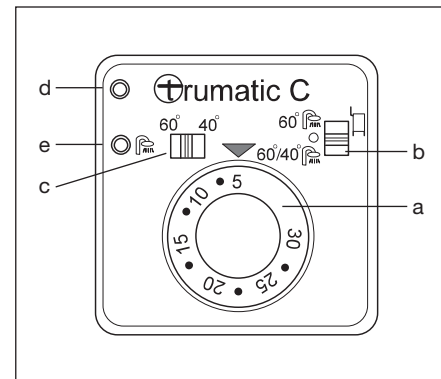

#### CONTROL PANEL WITH THERMOSTAT

- a = Rotary control knob for room temperature (illuminated by green indicator lamp “Operation”)
- b = Slide valve:
  - Heater + water heater (Winter operation)
  - Off
  - Water heater (Summer operation)
- c = Slide valve for water temperature 60° or 40° C (summer operation)
- d = Red indicator lamp “Failure ”
- e = Yellow indicator lamp “Water heater heating up phase”

### SWITCHING ON

1. Check that the cowl is not obstructed. Always remove any covers.
2. Turn on gas cylinder and open quick-acting valve in the gas supply line.
3. Set slide valve (b) to “winter operation” or “summer operation”.
4. In winter operation select required room temperature at rotary control knob (a).
5. In summer operation set slide valve (c) to required water temperature.

### SWITCHING OFF

Set slide valve (b) to centre position. When the appliance is switched off after a heating phase, the fan may continue running in order to utilize the residual heat .

**Always drain water contents if there is a risk of frost!**

If the appliance is not to be used for a prolonged period, close the quick-acting valve in the gas supply line and turn off the gas cylinder.

### GREEN INDICATOR LAMP “OPERATION” (UNDER ROTARY CONTROL KNOB)

When the appliance is switched on the green indicator lamp is illuminated. If this indicator lamp is not illuminated, consider the provided (main) switch. For this purpose observe the respective instructions of the vehicle manufacturer.

### FUSES

The appliance fuses are on the electronic control unit on the appliance.

**Important note:** Only replace the miniature fuses F1 and F2 on the electronic control p.c.b. with fuses of the same type.

F1 = 4 AT (slow action)

F2 = 0,5 AF (quick-action)

**Attention:** The fuse F3 is only to be replaced by an expert .

### RED INDICATOR LAMP “FAILURE”

The red indicator lamp (d) lights up **permanently** if there is a failure. Possible causes are: no gas, insufficient combustion air, fuse failure etc. Deactivate by switching off and then switching on again.

Flashing 1 x per second indicates insufficient operating voltage, flashing 2 x per second indicates that the operating voltage is too high for the appliance.

### FILLING THE BOILER

1. Ensure that the yellow lever on top of the drain valve is in the horizontal (closed) position.
2. Switch on power for water pump (main switch or pump switch).
3. Open hot water taps in kitchen and bathroom, (set preselecting mixing taps or single-lever fittings to “hot”). Leave taps open until the water heater has forced out air and filled up with water and water is flowing out of the taps.

### DRAINING THE WATER HEATER

1. Interrupt power for water pump (main switch or pump switch).
2. Open hot water taps in kitchen and bathroom.
3. Set switch (9) to “0”.

Lift the yellow lever on the drain valve to the vertical (open) position.

**There shall be no guarantee for damage caused by frost!**

### MAINTENANCE

Use wine vinegar for de-scaling the water heater. This is best introduced into the appliance via the water supply. Allow the product to react and then thoroughly flush out the appliance with plenty of fresh water.

## Equipment Details

### SPECIAL VERSION WITH ADDITIONAL ELECTRIC HEATING 230 V, 450 W

i = Rotary control knob On/Off

k = Yellow indicator lamp "Operation"

Set rotary control knob (i) for the electric heating to marking "1". The yellow indicator lamp (k) lights up.

The water temperature cannot be preselected. Automatic temperature limitation is approx 70°C.

**Note:** To heat the water in the water heater more quickly the appliance can be simultaneously operated with gas and electric power.

**Attention:** In "summer operation" the appliance is only to be operated with water (this applies to both gas and electrical operation)!

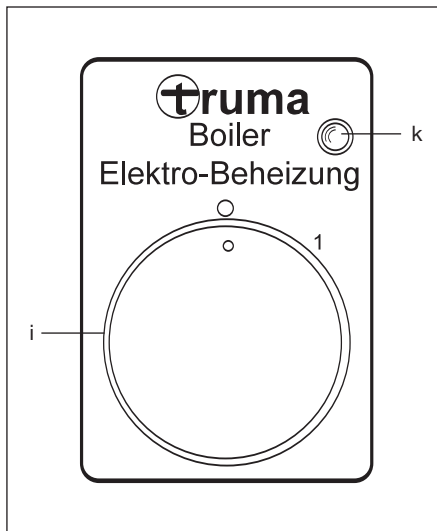

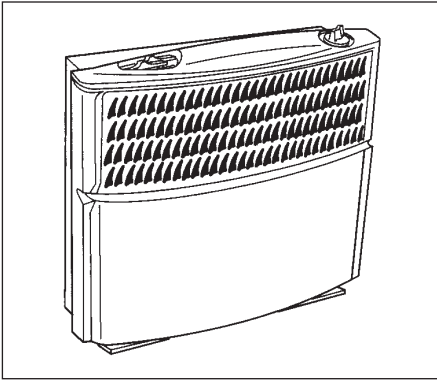

### CARVER SPACE HEATERS

Please read these cautions before using your heater.

In the event of a gas leak, immediately turn off all appliances and the gas supply at the cylinder. Contact your nearest approved service agent without delay.

- The gas supply to the heater must be from an approved pressure regulator of adequate capacity. Under **NO** circumstances should an industrial or adjustable regulator be used on motorhomes.
- The heater **MUST NOT** be operated while refuelling or when the vehicle is in a confined space such as a garage. The

heater **MUST NOT** be used if the flue has been damaged.

- The '2000', '4000' and '5500' ranges of heaters **MUST NOT** be used while the vehicle is in motion.
- The products of combustion pass through the vehicle floor and require unrestricted air entry beneath the vehicle into which it is fitted. A minimum of 3 sides of the vehicle **MUST** be exposed at all times. This is to allow for dispersal of the underfloor combustion products. If there is a possibility of the sides becoming blocked by snow or mud, then the heater **MUST NOT** be used. Every effort must be made to clear obstructions before use.
- There **MUST NOT** be a mantelpiece or shelving sited above the heater.
- Curtains **MUST NOT** hang within 150mm of the sides of the heater, or within 300mm of the top of the appliance.
- **DO NOT** place furniture or upholstery closer than 5mm to the sides of the heater.
- Where children, the elderly or infirm are present, we recommend that a guard be fitted around the heater when in use.
- Always wait three minutes before attempting to relight the heater after switching off or the heater going to fail safe shut down.

- **DO NOT** obstruct the gap at the bottom of the heater or the outlet grille slots.
- This heater does not contain any asbestos or asbestos related products.
- Aerosols and highly inflammable materials **MUST NOT** be stored in compartments behind or adjacent to the heater.
- This heater must be switched off and the gas supply turned off while the vehicle is in motion.
- When the heater is first used, it is recommended that you open a window or door and turn the temperature setting to maximum for one hour. This will allow any odours when first using the appliance to escape. Note: If odours persist, contact your local distributor.

### CARVER 2000P, 2000A and FANMASTER

#### To Light and Adjust the Heater – Gas Operation

1. Ensure the gas is turned on at the cylinder.
2. **Lighting the Heater:**  
**2000P, and 2000 Fanmaster**

Press the control knob (3) down and turn to the 'LOW/⚡' position (4) and then press firmly downwards. A click will be heard as the igniter operates, to light the heater. If a gas cylinder has been replaced, it may require several operations of the igniter to

## Equipment Details

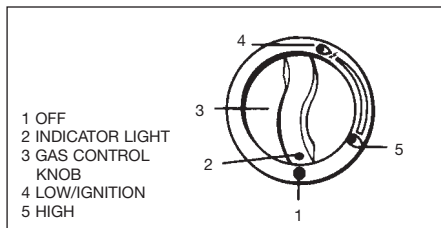

light the flame. Observe through the viewing windows on the lower half of the front case, that the burner lights.

### 2000A and 2000 Fanmaster (12V 'Auto' Ignition)

As above turn to the '⚡' position and press firmly down. A continuous ticking will be heard, as the spark generator is actuated. An indicator light (2) built into the control knob will light up when the flame is lit.

3. Continue to hold the knob down for 20 seconds and release. The flame supervision device will now have been actuated. The knob can now be released and adjusted to the desired setting as marked on the heater top panel.
4. If the burner is extinguished for any reason, or fails to remain alight, the heater will shut down to a safe condition. In the case of the 12V 'Auto' ignition models (2000A and Fanmasters with this ignition device), the continuous ticking of the

spark generator will be heard until turned off.

5. To turn off the heater at any time, turn the knob to the 'O' (1) position.
6. Wait for at least 3 minutes, after shut down, before attempting to relight these heaters.

### Electric Heating – Fanmaster models only

#### Cautions:

- Read the operating instructions before using the Fanmaster.
- Read the operating instructions for the Carver gas heater before using it in conjunction with the Fanmaster.
- One or more duct outlets must be open whilst the Fanmaster is in use.
- The 230V external supply to the vehicle must be disconnected before driving off.

#### General Description

The Fanmaster is an automatically controlled fan designed to distribute warm air around the motorhome via ducting.

All of the functions of the 2000 Fanmaster are controlled independently of the gas control – by front case slide switches when right-hand build is installed (Fig. 1), or by wall-mounted control panel for a left-hand installation (Fig. 2).

Fig. 1

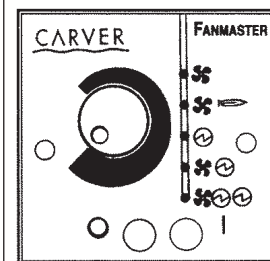
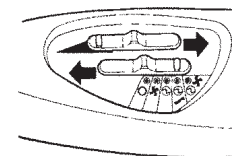

Fig. 2

The air is heated either by the Fanmaster's own electric element or by the Carver gas fired heater. Both the Carver gas heater and the Fanmaster can be used at the same time providing the fan is in operation.

The built-in elements are automatically or manually switchable between 0, 1kW and 2kW and require a 230V AC mains supply drawing a maximum of 8A at 2kW.

When using electric heating, the motorhome temperature is regulated by the thermostat mounted at the top of the installation box, but when using the gas heating the temperature is controlled by the gas heater thermostat. The night setting is a 1kW convector heater setting. In the summer the fan may be operated without any heat input to distribute cool air.





The Fanmaster has an air deflector allowing the majority of air to be directed down one fan outlet. For example, down the longest ducting run. This may have been preset on installation.

The duct outlets are generally of the butterfly type and may be opened or closed by adjusting the butterfly valves. Twisting the disc in its housing directs the flow in the direction required. One outlet on each leg of the duct layout must be kept open.







### Servicing

In order to ensure that your heater continues to operate effectively, you will need to arrange for it to be serviced at least once a year by a competent and trained service engineer. By law no one is permitted to deal with the installation and servicing of gas appliances unless they have proven competence. Contact your nearest authorised motorhome distributor if service or repair is required.

### FANMASTER CONTROLLER OPERATIONS - SLIDE SWITCH ON HEATER TOP (R.H. INSTALLATION)

| POSITION | OPERATION (without gas)   | OPERATION (with gas)   |
|----------|---|--|
| 0        |  Off   | Gas convector  |
| 1        |  Manual fan speed. Temperature slider governs the fan speed. For cool air distribution.      | Blown hot air distribution   |
| 2        |  1kW electric convector heating, no fan. Temperature slider selects desired room temperature | Electric and Gas convection, but a high gas heater output will inhibit the electric heating to maintain safe operating temperatures. |
| 3        |  1kW electric fan heating, fan remains slow.   | Electric and Gas blown distribution. Fan speed adjusts automatically based on outlet temperature.                                    |
| 4        |  2kW electric fan heating. Fan automatically adjusts speed to suit.                          | Electric and gas blown distribution. Fan speed adjusts automatically.  |

### FANMASTER CONTROLLER OPERATIONS - WALLSWITCH CONTROL (L.H. INSTALLATION)

| POSITION | OPERATION (without gas)  | OPERATION (with gas)  |
|----------|--|---|
| 0        |  Off  | Gas convector   |
| 1        |  Manual fan speed. Wall switch knob governs the fan speed. For cool air distribution.       | Blown hot air distribution  |
| 2        |  Automatic fan speed. Temperature of heater governs fan speed.                              | Blown hot air distribution with automatic fan speed control.                                      |
| 3        |  1kW electric convector heating, no fan. Wall switch knob selects desired room temperature. | Electric and gas blown distribution. Fan speed adjusts automatically based on outlet temperature. |
| 4        |  1kW electric fan heating, fan remains slow.  | Electric and gas blown distribution. Fan speed adjusts automatically.                             |
| 5        |  2kW electric fan heating. Fan automatically adjusts speed to suit.                        |   |

## Equipment Details

### CARVER 4000 and 5500 TURBO FANMASTER SPACE HEATER

**Read the cautionary notes for the Carver Space Heaters before using your heater.**

#### Before Lighting the heater:

Ensure the gas is turned on at the cylinder.

#### Lighting the Heater (Fig. 3)

For the auto ignition press the control knob (4) down and rotate to the '⚡' position (2), maintaining downwards pressure. The igniter will be heard to operate with a continuous 'ticking' noise. On ignition the control knob indicator (3) will illuminate to show that a flame is present.

After the burner has lit, continue to hold down the control knob for a further 10 seconds. Release the control knob and the indicator should remain illuminated to show that the burner has remained alight.

For the Piezo ignition, press the control knob (4) down and rotate to the '⚡' position (2), maintaining downwards pressure. Press the ignition button (7). Check through the viewing window on the front case that the pilot burner is alight, if so continue to hold the control knob down for ten seconds.

Release the control knob and the pilot burner should remain alight. It may require several operations of the igniter to light the burner.

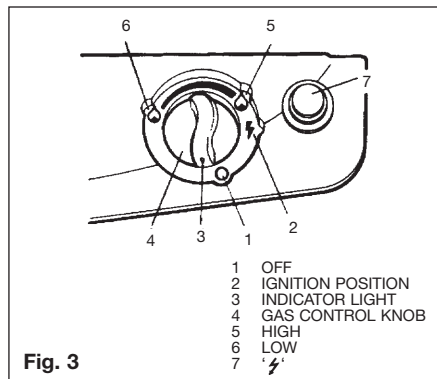

To operate the main burner, turn the control knob further anti-clockwise and set it at the desired comfort level, between the high flame and low flame positions (5 & 6).

The main burner will 'cycle' automatically as required by the thermostat to maintain the set temperature, but the pilot light will always remain alight.

#### Turning off the heater

Turn the control knob fully clockwise to the '•' position (1).

### FANMASTER

#### General Description

The Fanmaster is an electric heating and blown air system controlled by the slider switches on the front case of the heater (Fig. 4).

The automatically controlled fan distributes warm air around the motorhome via ducting. The air is heated either by the Fanmaster's own electric element or by the Carver gas fired heater. The Carver gas fire and the Fanmaster can be used at the same time providing the fan is in operation.

The built-in elements are automatically or manually switchable between 0, 1kW and 2kW and require a 230V AC mains supply drawing a maximum of 8 amps at 2kW. The fan requires a 12V DC supply and will take 1.5A at maximum speed.

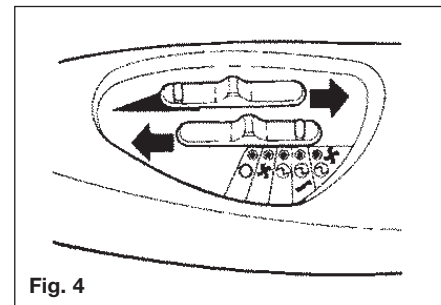

When using electric heating the motorhome temperature is regulated by the thermostat mounted at the bottom right of the installation box, but when using the gas heating the temperature is controlled by the gas heater thermostat. The night setting is a 1kW convector heater setting. In the summer the fan may be operated without any heat input to distribute cool air.

The air ducting outlets are generally of the butterfly type and may be opened or closed by adjusting the butterfly valves. Twisting the disc in its housing directs the flow in the direction required.

One outlet on each leg of the air ducting layout must be kept open at all times.





### Note:

Mains hook-up is needed for positions 2, 3 and 4. The current consumption will be approximately 4A for positions 2 & 3 and approximately 8A for position 4.

If you suspect that your mains hook-up is inadequate to supply the 8A required for position 4 in addition to your existing mains load, then for initial warm-up, use the Carver gas heater on a high setting and the Fanmaster on the position 1 setting.

When comfortable, change to either positions 2 or 3 and turn the gas heater off.

## FANMASTER CONTROLLER OPERATIONS (Fig. 2)

| POSITION | OPERATION (without gas)   | OPERATION (with gas)   |  |
|----------|---|--|--|
| 0        |  | Off  | Gas convector  |
| 1        |  | Manual fan speed. Temperature slider governs the fan speed.<br>For cool air distribution.    | Blown hot air distribution   |
| 2        |  | 1kW electric convector heating, no fan. Temperature slider selects desired room temperature. | Electric and Gas convection, but a high gas heater output will inhibit the electric heating to maintain safe operating temperatures. |
| 3        |  | 1kW electric fan heating, fan remains slow.  | Electric and Gas blown distribution. Fan speed adjusts automatically based on outlet temperature.                                    |
| 4        |  | 2kW electric fan heating. Fan automatically adjusts speed to suit.                           | Electric and gas blown distribution. Fan speed adjusts automatically.  |

### Typical mains current consumption is:

|                               |              |
|-------------------------------|--------------|
| Carver Cascade 2 water heater | 3.6A approx. |
| Travelling kettle             | 3.2A approx. |
| Battery charger               | 1.0A approx. |
| Portable colour TV            | 0.3A approx. |
| 60w light bulb                | 0.3A approx. |
| Fanmaster on position 4       | 8.3A approx. |
| Fanmaster on position 2 or 3  | 4.2A approx. |

The normal mains supply to UK sites are rated at 16A but some sites have only a 10A capacity.

### Servicing

In order to ensure that your heater continues to operate effectively, you will need to arrange for it to be serviced at least once a year by a competent and trained service engineer. By law no-one is permitted to deal

with the installation and servicing of gas appliances unless they have proven competence. Contact your nearest motorhome distributor if service or repair is required.

### Safety

To prevent over-heating of the electric elements at least one warm air outlet must be open at all times. It is recommended that one outlet should be of the non-closable type and not a butterfly.

If all the outlets are closed the self-hold thermal trip will switch off the power to the elements. If this happens, open the outlets, switch the heater power off and wait until the unit has cooled down, the unit will then reset itself.

## Equipment Details

Make sure that clothing etc. is kept clear of the back of the heater.

### Warranty Conditions

The space heaters are covered by a two year guarantee from the date of purchase of the appliance or the registration date of the vehicle in which it is installed.

The guarantee is liable for all manufacturing faults and defective components.

We strongly advise that all repairs on the unit are carried out by authorised Service Centres.

The guarantee does not cover installation errors, tampering or damage caused by frost.

### BUTTERFLY OUTLETS

The butterfly plate may be opened or closed to control the quantity of air and may also be twisted around to control direction.

For uniform distribution, outlets nearest the heater should be closed more than those further away.

### SEAT SWIVEL

The operation of some seat swivels may require the handbrake to be released. If this is necessary, please ensure that the engine is switched off and the vehicle is in gear.

Re-engage the handbrake and take the vehicle out of gear as soon as the seat has been rotated.

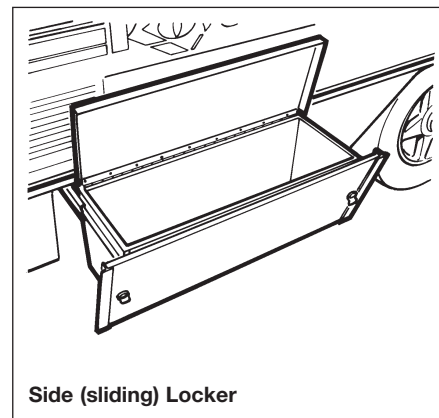
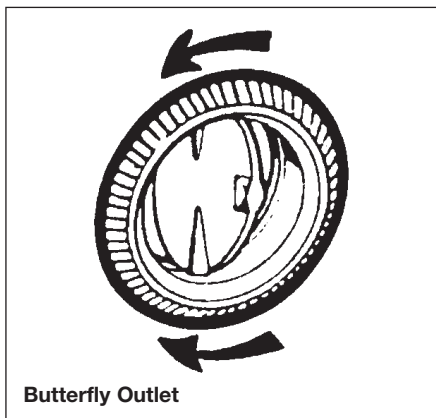

### SIDE (SLIDING) LOCKER

Some models are provided with exterior access locker doors. These are suitable for storing external equipment.

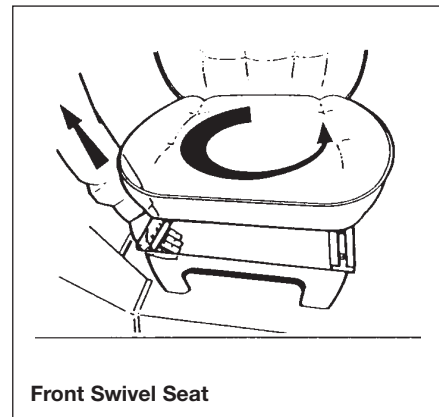

## BEDDING

Sleeping bags and continental quilts can be compressed into small spaces and can be ready to use in minutes.

**WARNING:** Always ensure safety boards are located before entering the bunk.

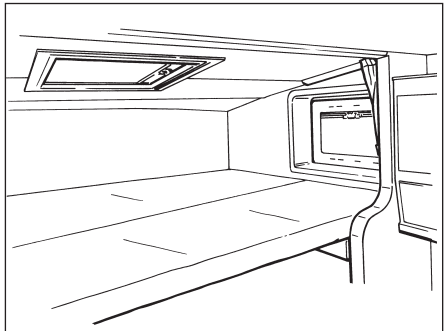

Typical bed arrangement on the Luton style Motorhome

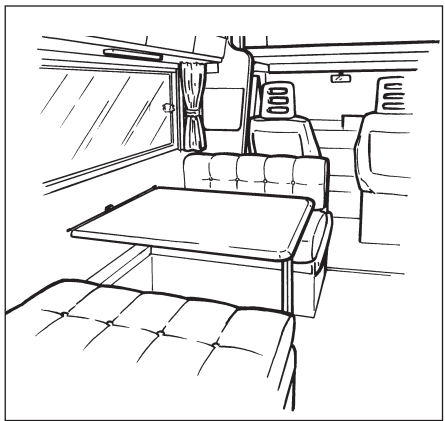

## FREE STANDING TABLE

**Note:** The free standing table legs have a positive locking mechanism. Care must be taken to ensure that, when folded, the leg which is closed first locks into the second position.

When engaging legs in down position the mechanism must be positively locked down.

**CAUTION!**  
When erecting the free standing table, be careful to avoid trapping fingers.

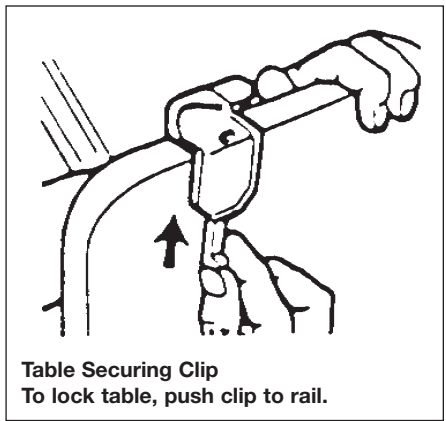
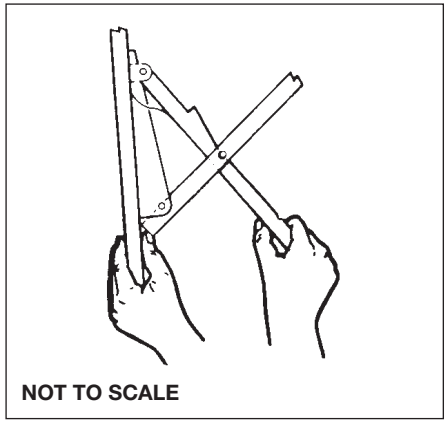

Table Securing Clip  
To lock table, push clip to rail.



NOT TO SCALE

## Equipment Details

### ROOF LIGHTS

When opening the roof lights, care must be taken to release the locking mechanism as the unit is raised.

Roof lights must be fully closed when driving.

Roof lights provide 12,500mm<sup>2</sup> of fixed ventilation each.

### WINDOWS

Some opening windows have two catch positions. The first position is for ventilation the second seals the window from ventilation and rain.

#### HEKI-1 ROOF LIGHT (SEITZ)

To open the lift/tilt roof light, turn the hand crank until a resistance is felt - maximum angle of opening 70°.

To close the lift/tilt roof light, turn the hand crank until the glass pane is lying in position, then turn for another 2-3 turns to lock the roof completely. Check the roof is completely locked (lift the glass by hand).

Only use the tilt mechanism when the roof is in the closed locked position.

Always use two hands to tilt the roof light  
Heki-1 roof lights give no fixed ventilation.

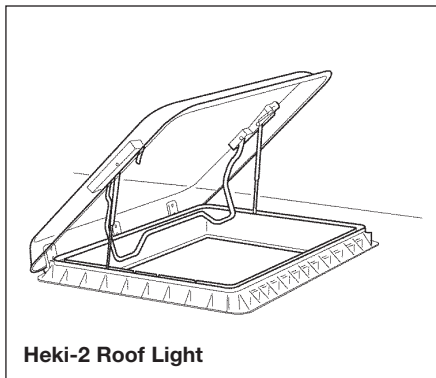

**Heki-2 Roof Light**

#### HEKI-2 ROOF LIGHT (SEITZ)

The lift/tilt roof light can be set in 3 positions by means of pneumatic springs.

Position 1 lifts the pane 12mm without allowing rain to enter the caravan.

Position 2 sets the pane to a 150mm opening and locks with a bar.

Position 3 opens the pane through 55°.

A fully adjustable flyscreen and black-out screen are built into the inner frame. The flyscreen can be drawn independently and the black-out screen is variable for partial or full black-out.

Forced ventilation functions via a brush lined duct instead of a ventilated pane.

A cover hood can be fitted for winter protection.

Heki-2 roof lights provide 13,200mm<sup>2</sup> of fixed ventilation.

Close the roof light completely before driving.

Do not operate whilst the vehicle is moving.

Do not stand on the roof light.

Do not leave your vehicle whilst the roof light is open.

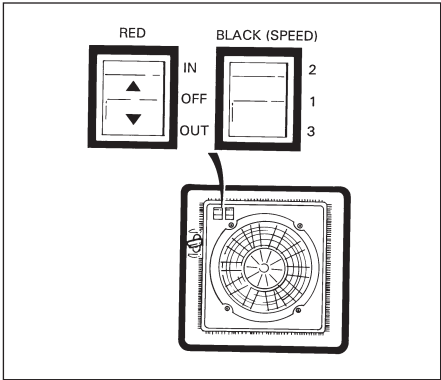

## ASH FRAMED DOORS

In order to provide customers with the latest designs of door furniture it is possible, due to the use of natural wood, that warping may occur. This should not detract from the correct functioning of items fitted in the motorhome.

## SHOWER

When using the shower, always ensure that the shower curtain is fully drawn thus avoiding water spray on unprotected areas.

## THE OMNIVENT (12V) ROOFLIGHT

The Omnivent is a double glazed rooflight constructed from a synthetic ultra-violet screened material. Its side operating mechanism allows a completely free central opening with built-in fixed ventilation when closed.

### Red Switch = Mode of Operation

Induction (IN)  
Expel (OUT)



### Black Switch = Speed Control

1, 2 and 3

Omnivents give no fixed ventilation when set on induction.

# MOTORHOME CARE

|                                    |           |
|------------------------------------|-----------|
| <b>Motorhome Exterior .....</b>    | <b>70</b> |
| <b>Motorhome Interior .....</b>    | <b>71</b> |
| <b>Chassis and Rear Axle .....</b> | <b>72</b> |
| <b>Exhaust Systems .....</b>       | <b>72</b> |
| <b>Winterisation/Storage .....</b> | <b>72</b> |

# Motorhome Care

## MOTORHOME EXTERIOR

### PAINTWORK

The exterior of your coachbuilt motorhome is finished with glass reinforced plastic (GRP) which is very durable and easy to clean owing to its smooth finish. GRP is now used extensively in modern motorhome construction and if cared for properly will enhance the appearance of your vehicle. To maintain a showroom finish wash the motorhome regularly with a mild detergent, rinse with cold water and leather off. A good quality, silicon free car wax may be applied which will make washing even easier.

Under no circumstances use any abrasive cleaning agents on the exterior of your motorhome. Stubborn stains may be removed by using a soft cloth and a mild detergent.

**WARNING: Overzealous use of detergents may loosen the decals and/or badges.**

**WARNING: Care should be taken as the silicon in some polishes can attack the rubber used on the exterior for seals and gaskets.**

## MOULDINGS

Some mouldings are anodised aluminium and will retain their lustre for a long period if no abrasive materials are used to clean them. If your motorhome is subjected to constant changes of temperature, mastic may seep from joints between the mouldings. Any excess that appears can be removed by simply wiping with a soft cloth.

**WARNING: Do not wash motorhome with a high pressure washer. These can cause permanent damage to the seals of your motorhome.**

## ACRYLIC WINDOWS

The windows in your motorhome are fully double glazed and with care will remain sparkling and scratch-free.

### Keeping your acrylic windows sparkling:

**Small Scratches:** For small scratches use a liquid metal polish or a proprietary acrylic polish of a suitable grade dependent upon the severity of the scratches.

**Cleaning:** Wash down as you would your car. Do not use a sponge on dirty windows. When all dirt has been removed, dry with a leather or similar type cloth. The catches and stays do not require lubricating.

**Removing Tar:** Use a proprietary tar remover on your double glazed windows, it is obtainable from most leading car accessory or Do-It-Yourself shops. Do not use petrol or other chemicals.

### MOTORHOME INTERIOR

#### SIDE WALLS AND ROOF LINING

A simple wipe over with a damp cloth and a very mild detergent is all that is needed.

#### SOFT FURNISHINGS

These should be vacuumed occasionally to remove grit and sand and help to keep its smart appearance and ensure long life. The upholstery can be cleaned with a mild, reputable upholstery cleaner. It is recommended that the curtains are dry cleaned only.

#### WORK SURFACES

Work surfaces are made with heat resistant tops.

**Note:** You should not stand very hot items on any of the work surfaces, especially models with plastic moulded sink and drainers.

#### CUPBOARD CATCHES

It is advisable to lightly oil all cupboard catches, sliding bolts, telescopic bed slides and hinges from time to time.

### BATHROOM, SHOWER ROOM AND KITCHEN EQUIPMENT

All the Thermoplastic parts in these areas have easy clean surfaces. To ensure long life and prevent damage you must not use any cleaning materials at all and ensure water temperatures do not exceed 70°C, (putting cold water in first is suggested). After every use it is essential that you rinse with clean water only and wipe with a soft damp cloth. Failure to follow these simple instructions may result in premature failure or cracking which will not be covered by any guarantees (including extended warranties).

#### CONDENSATION

Condensation will always occur when humidity inside your motorhome exceeds 60 per cent. Correct heating and ventilating of your motorhome will help to control condensation. We therefore recommend that you make sure your motorhome is heated and ventilated correctly at all times of the year, particularly in inclement or very wet weather. It will assist in reducing condensation if the windows are left in the night latch position.

### FURNITURE

A simple wipe over with a damp cloth should be all that is required. Polishing with a proprietary brand of wax polish enhances and maintains furniture in showroom condition. Follow these guidelines to ensure your investment is receiving the very best attention.

It must be remembered that because the frames of the doors are made of ash, which is a natural product, they can be affected by temperature and humidity and may bow under certain conditions. As conditions change they may revert to their original positions.

# Motorhome Care

## CHASSIS AND REAR AXLE

Some models are built on Fiat Ducato or Peugeot Boxer base vehicles, the chassis of which has been converted by Al-Ko. This conversion provides a hot dipped galvanised steel chassis coupled with a wide track rear axle utilising steel torsion bar suspension, imparting vastly improved stability and road holding. The rear axle is provided with a grease nipple at either side. Apply grease every 5,000 miles (8,000 kilometres) or at least once a year.

## Al-Ko EXHAUST SYSTEM

A standard Fiat exhaust system is fitted utilising an Al-Ko modified tail pipe, available through your approved dealer.

A standard Fiat exhaust system is fitted to all other models, with the addition of a Swift Group tail pipe.

## WINTERISATION/STORAGE

This is probably an opportune moment to arrange for the motorhome to have its annual service at your appointed dealer.

The following applies wherever your motorhome is stored particularly during the winter months.

Do not park near trees or larch type fences, due to possible wind damage.

Keep any grass around the floor of the motorhome short, to maintain air flow and stop any possible damp getting into the motorhome.

It is advised that the motorhome is ventilated regularly throughout the winterisation/storage period, opening windows, doors and rooflight when possible.

### General

All moving parts should be checked for free operation.

Clean all cooking appliances and refrigerator.

Lubrication should be carried out at the points illustrated in the general notes on chassis maintenance.

Charge the on-board battery every 2 months.

Leave the refrigerator door open.

Leave furniture doors and lockers open to allow air to circulate fully.

### Soft Furnishings

Clean and dust the upholstery and if possible remove before placing the motorhome into winter storage. Alternatively, stand the cushions on their edges to allow circulation of air. This will reduce the possibility of dampness from condensation.

Keep curtains or blinds closed, to minimise fading of furniture.

## Wheels and Tyres

Do not store in one position with partially deflated tyres. The tyre walls will suffer and present a real danger of blow outs, especially when travelling at faster speeds than are allowed in the UK.

The wheels should be turned every couple of weeks.

If you are removing the wheels, follow the jacking procedure for changing a wheel.

## Water System

The Carver Cascade water heater MUST be drained to prevent frost damage. The drain plug, which is on the outside of the flue cowl, should be unscrewed to permit draining. When the plug reaches the end of the thread the plug can be pulled out a small distance, yet still be retained in the thread and permit draining to occur. To allow the system and the tank to drain effectively, open ALL hot and cold taps while the heater is still warm.

Remove shower head.

The Thetford Cassette porta potti is easily winterised for storage. Empty the fresh water tank using the drain tube/fresh water tank level indicator (level indicator on electronic models only). Pull the lever indicator/drain tube down from top plug position and outward through door opening to drain water from the tank.

Empty the water fill funnel by pulling the bottle away from tank. Remove the small water cap on the filler bottom, allowing water to drain from the water funnel.

Do not tighten caps, this helps in keeping unit dry.

The pour out spout and vent plug can be removed. Seals should be greased if necessary with acid-free vaseline.

Remove the drain stop plugs on the fresh water pipes. These are located through the floor on the underside of the motorhome.

If a fresh water tank is fitted, drain the tank via underfloor drain tap/plug.

Leave the drain plugs and taps open.

The motorhome may be left in this condition over winter or until ready to use. It is recommended to leave the taps in the open position during storage.

### **Recommissioning the Water System**

Fill the fresh water tank on the Thetford Cassette porta potti (certain models only) using a hose or jerrycan until the water in the funnel reaches the neck. Tank capacity is 15 litres. Aqua Rinse may be added to improve cleaning of bowl and flushing of unit.

Replace cap. Swing back the water fill funnel until it touches the water tank.

Add Aqua Kem (100 ml) into the Cassette (or 120 ml if using Aqua Kem Bio) through the

pour out spout. Add small amount of water through the pour out spout and replace the cap.

Close the cold taps and ensure all the drain plugs are fitted.

It is advisable after storage to flush the water system initially with a sterilising agent (such as Milton), and then with water repeating until the system is well flushed through.

Connect the pump.

Fill the system with water until water flows freely from the hot taps. About 2 gallons of water will be required. Close the hot taps.

### **Appliances**

Before starting motor caravanning after storage, check all gas appliances and electrical points.

Note: Preferably not less than once a year, the electrical installation should be inspected and tested by a qualified electrician.

After storage it is advisable to air the motorhome and clean throughout, especially cooking appliances and the refrigerator.

Replace the bedding and wheels if they were removed for storage.

### **Important**

Always follow the manufacturer's recommended procedures after use of fitted equipment in the motorhome and before storing for any length of time.

# USEFUL INFORMATION

|   |    |
|---|----|
| <b>Swift Group Spares and After Sales</b> ..... | 76 |
| <b>Repair Facilities</b> .....                  | 76 |
| <b>Caravan Clubs</b> .....                      | 77 |
| <b>Motoring Organisations</b> .....             | 77 |
| <b>Trade Association</b> .....                  | 77 |

## Useful Information

### MOTORHOME INFORMATION

Date of purchase .....

Supplying dealer .....

CAB Chassis No .....

Motorhome Serial No .....

### SWIFT GROUP SPARES AND AFTER SALES

There are numerous items available from your dealer in the specially packaged 'Swift Group Spares', ranging from door catches through to spare wheels and touch-up paints. Please note that all after sales enquiries must be directed through your supplying dealer. The after sales service at the factory is geared to support our dealer network as is the service provided by appliance manufacturers.

**NB** Please remember to quote chassis number when ordering any items from your dealer.

### CUSTOMER CARE

The times for contacting Customer Care by telephone are: 9am to 4pm Monday to Thursday and 9am to 12.45pm Friday.  
Tel: 01482 875740 Fax: 01482 840861.

### Swift Group Website

[www.swiftleisure.co.uk](http://www.swiftleisure.co.uk)

### Swift Group E-Mail Enquiry

[enquiry@swiftleisure.co.uk](mailto:enquiry@swiftleisure.co.uk)

### REPAIR FACILITIES

Should you be unfortunate enough to suffer a major accident with your motorhome it is comforting to know that Swift has a completely separate repair shop facility where their fully trained experts will undertake all types of major damage repair work.

Repairs of a minor nature should be referred first to your local dealer.

The enjoyment of caravanning can be greatly enhanced by membership of one or more of the various caravanning, motoring and holiday clubs. Here are some useful addresses:

### **CARAVAN CLUBS**

#### **The Caravan Club**

East Grinstead House  
East Grinstead  
West Sussex RH19 1UA  
Tel: 01342 326944

#### **The Camping and Caravanning Club**

Greenfields House  
Westwood Way  
Coventry  
West Midlands  
Tel: 01203 694995

### **MOTORING ORGANISATIONS**

#### **Automobile Association (AA)**

Fanum House  
Basingstoke  
Hants. RG1 2EA  
Tel: 0990 448866  
[www.theaa.co.uk](http://www.theaa.co.uk)  
e-mail: [customer.services@theaa.com](mailto:customer.services@theaa.com)

#### **RAC Motoring Services**

RAC House  
M1 Cross  
Brent Terrace  
London NW2 1BX  
Tel: 0990 722722

#### **Green Flag National Breakdown**

PO Box 300  
1 Cotes Lane  
Leeds LS99 2LZ  
Tel: 0345 670345

### **TRADE ASSOCIATION**

#### **National Caravan Council**

Catherine House  
Victoria Road  
Aldershot  
Hampshire GU11 1SS  
Tel: 01252 318251  
[www.martex.co.uk/hcc](http://www.martex.co.uk/hcc)  
e-mail: [mail@martex.co.uk](mailto:mail@martex.co.uk)

|          |   |    |                                   |                                 |          |                         |  |    |
|----------|---|----|-----------------------------------|---------------------------------|----------|-------------------------|--|----|
| <b>A</b> | After Sales Support .....               | 76 | Transformer/Charger KT12SM .....  | 28                              | <b>R</b> | Refrigerators .....     | 34                                       |    |
|          | Arrival at Site .....                   | 13 | Electricity .....                 | 20                              |          | Repair Facilities ..... | 76                                       |    |
|          | Awnings/Tents .....                     | 14 | En Route .....                    | 9                               |          | Rooflights .....        | 66                                       |    |
| <b>B</b> | Battery .....                           | 26 | Equipment Power Consumption ..... | 23                              |          | Roof Loading .....      | 7  |    |
|          | Battery Charger .....                   | 28 | <b>F</b>                          | Fanmaster Warm Air Heater ..... | 59/62    | <b>S</b>                | Safety & Security .....                  | 11 |
|          | Beds .....                              | 65 |                                   | Fire .....                      | 12       |                         | Security .....                           | 12 |
|          | Before moving off .....                 | 6  |                                   | Fuses .....                     | 29       |                         | Shower .....                             | 67 |
|          | Blown Air Heating (Carver P4) .....     | 33 | <b>G</b>                          | Gas .....                       | 18       |                         | Side Locker .....                        | 64 |
|          | Butterfly Outlets .....                 | 64 |                                   | Butane Gas .....                | 18       |                         | Space Heaters .....                      | 59 |
| <b>C</b> | Caravan Clubs .....                     | 77 |                                   | Propane Gas .....               | 18       |                         | Spares .....                             | 76 |
|          | Carver 2000P, A & Fanmaster .....       | 59 |                                   | Regulators .....                | 18       |                         | Spare Wheel Removal .....                | 10 |
|          | Carver 4000P, A, 5500 & Fanmaster ..... | 62 |                                   | Gas Safety .....                | 19       |                         | Stoves 8000/9000 Cooker .....            | 44 |
|          | Carver P4 Blown Air Heater .....        | 33 |                                   | Generator Guidelines .....      | 30       |                         | Stoves Combination Oven .....            | 43 |
|          | Carver Space Heaters .....              | 59 |                                   | Grills .....                    | 45/46    |                         | Stoves Vanette Hob & Grill .....         | 46 |
|          | Cascade 2 GE Water Heater .....         | 32 | <b>H</b>                          | Heating .....                   | 56       | <b>T</b>                | Swivel Seats .....                       | 64 |
|          | CEC 225 Unit .....                      | 27 |                                   | Hobs .....                      | 45/46/47 |                         | Table .....                              | 65 |
|          | Changing a Wheel .....                  | 10 | <b>L</b>                          | Levelling the Vehicle .....     | 14       |                         | Technically Permissible Laden Mass ..... | 6  |
|          | Codes of Conduct .....                  | 2  |                                   | Loading the Vehicle .....       | 6        |                         | Thermal Insulation .....                 | 23 |
|          | Camp Sites .....                        | 2  | <b>M</b>                          | Mains Inlet Cable .....         | 22       |                         | Theftford Cassette C-200 .....           | 49 |
|          | Coastal Code .....                      | 4  |                                   | Mains Unit (CEC 225) .....      | 27       |                         | Theftford Porta Potti .....              | 52 |
|          | Country Code .....                      | 4  |                                   | Motorhome Care .....            | 69       |                         | Toilets .....                            | 49 |
|          | Connecting Services .....               | 15 |                                   | Chassis/Rear Axle .....         | 72       |                         | Trade Association .....                  | 77 |
|          | Corner Steadies .....                   | 14 |                                   | Exhaust System .....            | 72       |                         | Transformer/Charger KT12SM .....         | 28 |
|          | Cramer Hob .....                        | 47 |                                   | Exterior .....                  | 70       |                         | Travel Catch .....                       | 42 |
| <b>D</b> | Distribution Panel KT9M5 .....          | 29 |                                   | Interior .....                  | 71       |                         | Trumatic C3400 & C6000 .....             | 56 |
|          | Doors .....                             | 67 |                                   | Winterisation/Storage .....     | 72       |                         | Tyres .....                              | 7  |
| <b>E</b> | Electrical Systems .....                | 25 |                                   | Motoring Organisations .....    | 77       | <b>U</b>                | Useful Information .....                 | 75 |
|          | Battery .....                           | 26 | <b>O</b>                          | Overseas Connections .....      | 21       | <b>V</b>                | Ventilation .....                        | 12 |
|          | Battery Charger .....                   | 28 | <b>P</b>                          | Payload Allowance .....         | 6        | <b>W</b>                | Water System .....                       | 16 |
|          | Distribution Panel KT9M5 .....          | 29 |                                   | Positioning the Motorhome ..... | 14       |                         | Water Pump (Shurflo) .....               | 32 |
|          | Fuses (12V) .....                       | 29 |                                   | Power System (12V) .....        | 28       |                         | Water Pump (Whale) .....                 | 32 |
|          | Generator Guidelines .....              | 30 |                                   | Preparing for the Road .....    | 5        |                         | Weights .....                            | 6  |
|          | Mains Unit .....                        | 27 |                                   |                                 |          |                         | Windows .....                            | 66 |
|          | Power System (12V) .....                | 28 |                                   |                                 |          |                         | Winterisation/Storage .....              | 72 |



Swift Group Limited  
Dunswell Road, Cottingham,  
East Yorkshire HU16 4JX  
Tel: (01482) 875740  
e-mail/web site: [www.swiftleisure.co.uk](http://www.swiftleisure.co.uk)

© 1999 SWIFT GROUP LTD



**Quality with Style**

**SWIFT MOTORHOMES, DUNSWELL ROAD, COTTINGHAM, EAST YORKSHIRE HU16 4JX.  
TEL: 01482 847332 FAX: 01482 840082 e-mail/web site: [www.swiftleisure.co.uk](http://www.swiftleisure.co.uk)**

Issued September 1999

9830014