

INTRODUCTION

DEAR OWNER

THANK YOU FOR DECIDING TO BUY ONE OF OUR NEW MOTORHOMES. WE ARE SURE YOU WILL ENJOY MANY HAPPY HOURS IN IT AND WE HOPE THE INFORMATION AND HINTS IN THIS HANDBOOK WILL HEIGHTEN YOUR ENJOYMENT.

THE HANDBOOK HAS BEEN DESIGNED TO GIVE YOU A GENERAL GUIDE TO THE CARE, USE AND MAINTENANCE OF YOUR MOTORHOME. WHETHER YOU ARE A NEW OR AN EXPERIENCED MOTORHOME USER THE HINTS WILL HELP TO PROTECT YOUR INVESTMENT.

THE INFORMATION CONTAINED WILL ANSWER MOST OF YOUR QUERIES, BUT IF THERE ARE ANY ASPECTS WHICH ARE NOT COVERED PLEASE CONSULT YOUR APPOINTED DEALER.

HAPPY TOURING!

IMPORTANT - PLEASE QUOTE THE 17 DIGIT NUMBER ON THE SWIFT MANUFACTURERS PLATE SITUATED ON THE BULKHEAD DIRECTLY BEHIND THE FRONT PASSENGER SEAT, AND BASE VEHICLE CHASSIS NUMBER IN ALL CORRESPONDENCE WITH YOUR DEALER OR SWIFT GROUP LIMITED.

All the illustrations and descriptive matter in this handbook are intended to give a general idea of the motorhome. Changing market and supply situations may prevent us from maintaining the exact specification details in this handbook. We therefore reserve the right to alter specifications as materials and conditions demand.

Dealers are not agents of Swift Group Limited and have absolutely no authority to bind Swift Group Limited by any express or implied undertaking or representation.

CONTENTS

The Motorhome Code.....	1
Preparing for the Road.....	5
‘En Route’	13
Safety & Security.....	15
Arrival at Site	19
Connecting Services.....	21
Electrical Systems	35
Equipment Details.....	51
Motorhome Care.....	107
Useful Information	113
Index.....	117

THE MOTORHOME CODE

Code of Conduct	2
The Country Code	4
The Coastal Code	4

Motorhome Code

CODE OF CONDUCT

CAMP SITES

Arrivals

Report to reception immediately on arrival.

Vehicle Movement

Keep to roadways unless otherwise directed.

Adhere to speed limits. Note that these are generally 10 mph. (Remember that the stopping distance on grass is considerably greater than on tarmac.)

Only a person in possession of a current driving licence may drive on the site.

Park correctly as advised on your pitch. Where possible leave 20 feet of free space around your vehicle.

Use of Site Appliances

Use the electrical mains hook-up in the correct manner and with caution.

Ensure that all fresh water taps/connections are turned off after use.

Have care and consideration when using all facilities (toilets and showers etc) and leave clean and tidy. Young children should be supervised.

Waste Disposal

If the vehicle is not fitted with a waste water tank, a suitable receptacle should be placed below all waste water outlet pipes. Do not let these containers overflow.

Dispose of all waste water where instructed.

Empty effluent from chemical toilets where instructed.

To avoid possible damage to sewage purification works, only approved chemical fluids must be used. Under no circumstances should coal tar, phenol or caustic-based fluids be used.

Disposable napkins and similar bulky items must not be put into chemical closet emptying points but should be wrapped in a polythene bag and placed in the container provided.

Place all litter in containers marked for the purpose.

Noise

Do not make excessive noise.

Children should be restrained from making excessive noise.

Flying kites and model aircraft and the use of items like catapults or air-guns, as well as ball games, should not be permitted among, or close to other vehicles.

Musical instruments, record players, radios and televisions should not be used to the inconvenience of other people on the site.

Open and close doors quietly.

Power generators must be adequately silenced and used with consideration.

Dogs and other Pets

All dogs and other pets should be kept under control.

Unless permission has been granted, no animal should be allowed loose on the site and leads must not exceed 10ft.

No animals should be allowed in the shower/toilet blocks.

Do not let dogs foul the site.

Fire Precautions

Adhere to and take note of fire precautions noting the whereabouts of the fire points.

WARNING: Provide one dry powder fire extinguisher of an approved type or complying with EN3, of at least 1kg capacity, by the main exterior door and a fire blanket next to the cooker. Familiarise yourself with the operating instructions on your fire extinguisher and the local fire precaution arrangements.

Motorhome Code

When using a dry powder extinguisher it is suggested that the motorhome be evacuated until the powder has settled, to avoid inhalation.

Unless permission has been granted, barbecues should not be used. If permission is given, consideration should be given to the annoyance that can be caused to other users of the site.

Open fires are not allowed.

Awnings and Tents

Awnings and tents should only be used when permission has been obtained.

When on grass and staying for more than a few days, the ground sheet and/or side flaps of awnings should be periodically raised in order to avoid damage to the ground.

Departure

Leave the pitch clean and tidy.

On leaving, check out with reception paying the required fees.

WILD CAMPING

Camping away from licensed sites, without the permission from the land owner or his agents, is not allowed in the United Kingdom.

When permission has been granted, all aspects of this Code should be adhered to.

On no account should:

- (a) Litter be disposed of other than in the receptacles provided.
- (b) Water be allowed to escape from the vehicle.
- (c) Chemical toilets be emptied except into the disposal places agreed with the land owner.
- (d) Washing or similar be hung outside the vehicle.

PARKING

Motorhomes should only be parked in approved places.

When using the facilities of a motorhome, care and consideration should be given to those around them.

DRIVING

When using a motorhome on either the public highway or private roads the Highway Code should be complied with and full consideration given to other road users.

In the event of a motorhome travelling slowly the driver of the motorhome should, where possible, pull over in order to let other traffic pass.

When the vehicle is in motion it is compulsory for all front seat passengers to wear seat belts and strongly recommended for rear seated passengers, where fitted.

Before moving off, elevated roofs and aerials should be lowered and correctly secured, and top hinged windows closed. Likewise all doors and access lockers for gas containers and chemical toilets must be properly secured.

Exterior steps should be properly retracted and secured.

When refuelling or on a ferry ensure the gas system is fully isolated at source.

HANDBOOK

Before using a motorhome all aspects of the handbooks, produced by the chassis manufacturer and the converter, must be read and adhered to.

The separate chassis manufacturer handbook refers to your motorhome chassis and base vehicle.

ENVIRONMENT

Care and consideration should be taken to protect the environment.

Observe the Country and Coastal Codes shown overleaf.

Motorhome Code

THE COUNTRY CODE

Enjoy the countryside but respect its life and work.

More people than ever before are exploring the countryside, interested in farming, plant life, bird watching or just observing the general wildlife. Whatever your interest, there is a lot to learn, but please observe the following code:

1. Guard against all risk of fires. Hay and heathland catch alight easily and once ablaze are very hard to put out.

REMEMBER: FIRE SPREADS QUICKLY.

2. Keep to the public paths across farmland.
3. Use gates and stiles to cross fences, hedges and walls.
4. Leave livestock, crops and machinery alone. View from a distance.
5. Take your litter home - it is unsightly and harmful to wildlife.
6. Help to keep all water clean.
7. Take special care on country roads.
8. Make no unnecessary noise. Most animals are very timid; noises can disturb them unnecessarily. If you want to get the best out of the country, go quietly.

THE COASTAL CODE

As our coastlines are increasingly used for recreation and education, the following suggestions are made to enable us to enjoy our inheritance and preserve it for posterity.

Disturbance may mean DEATH.

DO NOT trample about, or move rocks unnecessarily.

DO NOT frighten seals or seabirds.

DO NOT spill detergents, solvents or fuel from boats as these can kill marine life.

When sailing, moderate your speed - the wash from a fast boat can destroy banks and nests.

Live molluscs and crustaceans need not be collected as souvenirs - dead shells can usually be found.

Shellfish can take years to grow and fines can be imposed for not observing national regulations.

DO NOT pull up seaweeds unnecessarily.

Make your visit instructive - not destructive.

Look at material - don't remove it. Take notes and photographs, not specimens.

Observe by-laws and be considerate to others.

National Trust property and Country Parks have regulations to protect the wildlife. Follow these and the Country and Coastal Codes.

PREPARING FOR THE ROAD

Before Moving Off	6
Motorhome Terms	6
Loading of Vehicle	7
Large Storage Areas	8
Roof Loading	8
Tyres	8
Dedicated Travelling Passenger Seats	8
Three Point Seat Belts	9
Driving Licence.....	9
Vehicle Classifications	10
Advice on towing.....	10

Preparing for the Road

BEFORE MOVING OFF

Check:

- gas cylinders and all gas operated appliances have been isolated, including fridge, water heater, oven and space heater.
- gas cylinders are correctly positioned, secured and turned off.
- loose articles are stowed securely. Do not stow tins, bottles or heavy items in overhead lockers.
- all lockers and cupboard doors are closed and secured.
- all bunks and ladders are secure in their storage or place Luton ladder on its side in front of Luton bedboards.
- all rooflights are closed and secured.
- main table is stored in its transit position.
- fridge is on 12V operation and door lock is set.
- battery selection switch (Sundance/E400 /Ace/Sprite) is set to van position.
- Control panel power ON/ OFF button (Kon-Tiki / E700) is set to OFF position.
- tyre pressures and wheel nuts.
- rear corner steadies are raised.

- all drain taps are closed.
- exterior roof rack ladder is raised and secured.
- 230V mains input socket flap is securely closed.
- exterior step (where fitted) is retracted/folded in.

Special attention must be taken to ensure all top hinged windows as well as the Luton windows are closed when in transit. All units should be fully closed and latched to prevent damage. The motorhome exterior door should also be locked.

The entrance door must be closed before the central locking is activated.

Failure could result in being locked out of the vehicle if the keys are left inside.

MOTORHOME TERMS

Mass in Running Order:

This is the mass of the motorhome as stated by the manufacturer, i.e. ex works weight including the driver with 90% fuel and standard fixtures and fittings. All Swift Group motorhomes include Essential Habitation Payload items and the fluids required for safe and proper functioning of equipment for habitation use within the MRO being in compliance with European Directive 92/21/EEC (Masses and Dimensions).

Note: Quoted MRO subjected to tolerance due to weight variation of materials used in Motorhome construction.

Maximum User Payload:

The maximum allowable weight to be put into the motorhome whilst it is being driven. This is made up of 4 sections:

Personal effects, conventional load, optional equipment and essential habitation equipment.

The Maximum User Payload is the difference between the Maximum Technically Permissible Laden Mass and the Mass in Running Order.

Personal Effects:

Those items which a user can choose to carry in a motorhome and which are not included as Essential Habitation Equipment or Optional equipment.

Conventional Load:

A mass allowance for each designated passenger seat.

Optional Equipment:

Items made available by the manufacturer over and above the standard specification of the motorhome.

Maximum Technically Permissible Laden Mass:

The maximum weight for which the motorhome is designed for normal use when being driven on a road, laden.

Preparing for the Road

This mass takes into account specific operating conditions including factors such as the strength of materials, loading capacity of tyres etc.

WARNING: Under no circumstances should the Maximum Technically Permissible Laden Mass of this motorhome be exceeded.

Nose weight:

The static mass of the trailer towing device on the rear of the towing vehicle.

Notes:

- (i) When measuring the noseweight it is important that the trailer is loaded.
- (ii) The trailer is intended to be towed slightly nose heavy. The nose weight can be adjusted by distribution of the load. The nose weight should be approximately 7% of the actual laden weight (but not greater than the hitch capacity) and at the same time suit the motorhome requirements.
See 'Advice on Towing' page 10.

LOADING OF VEHICLE

WARNING: LOADS MUST NOT BE EXCEEDED.

THE DRIVER IS RESPONSIBLE FOR ARRANGING THE LOADS SO THAT THEY COMPLY WITH THE TECHNICAL WEIGHT LIMITS OF THE SPECIFIC MOTORHOME MODEL.

SEE SERVICE HANDBOOK.

Correct weight distribution is an important factor in ensuring your vehicle is well balanced and easy to drive. It is therefore necessary to load your motorhome carefully making sure all heavy articles are evenly distributed and are preferably placed in the lower lockers or bed boxes.

WARNING: Do not travel with televisions or microwaves in overhead lockers unless the appliance was supplied fitted to your motorhome by the manufacturer.

Although it is essential to ensure that the total weight of your motorhome does not exceed the stipulated Maximum Technically Permissible Laden Mass, (MTPLM), it is important to remember that the front and rear axles also have individual maximum weights which must not be exceeded.

To ensure adequate road holding the load on the front axle, under all conditions, must not be less than 42% of the total weight.

Ensure you distribute the payload equally on each side of the vehicle to avoid an imbalance.

These weights, together with the MTPLM, can be found on the Manufacturers Type Approval plate affixed to the bulkhead panel directly behind the front passenger seat.

WARNING: Turn off all gas appliances while the vehicle is in motion.

Please take care to ensure you have allowed for the masses of all the items you intend to carry in your motorhome e.g. passengers, optional equipment, essential habitational equipment and personal effects such as clothing, food, pets, bicycles, sailboards, sports equipment etc.

Preparing for the Road

LARGE STORAGE AREAS

The large storage areas provided in some motorhome layouts are designed solely for the purpose of carrying personal possessions, these areas **must not** be used;

- as a habitation area (eg living, sleeping or cooking).
- to carry passengers, animals or livestock.
- for the installation (or use) of any LPG gas operated appliances, (unless supplied fitted by the manufacturer).
- for carrying LPG gas bottle cylinders.
- to carry any flammable liquids, unless properly stored, sealed and secured.
- for the operation of an electrical generator.
- in such a way that the load exceeds the MTPLM, and/or minimum and maximum axle loads.

Care must be taken to ensure that exterior doors are closed, locked and that all possessions are properly stored and secured before setting off on any journey.

ROOF LOADING

A maximum load of 200kgs can be evenly distributed over the roof area. This figure **MUST NOT** be exceeded.

The roof areas, up to the over cab section, are capable of withstanding an average person's weight (13 stone or 82.5kg).

Note: Do not walk on the over cab section.

Some motorhome roofs can be fitted with a roof rack (optional).

It is permitted to stand inside the roof rack fitted to the roof. The roof section beyond the rack is not designed for walking on.

Note: When loading the roof rack, make sure the load is spread evenly and do not allow sharp objects to come into contact with the roof surface.

WARNING: When walking on the roof rack, deck type shoes should be worn - not leather soles.

Do not apply excessive load to the rear suspension of your motorhome or allow the vehicle to reverse with the roof rack access ladder in the down position, touching the ground. This may cause excessive strain on the ladder fixing points.

TYRES

If a wheel or tyre fitted to a wheel is changed any replacement must be of the same type of construction and size.

The law requires that the tyres and pressures must be suitable for the use to which they are being put. The minimum tread depth must be 1.6mm throughout a continuous band comprising the centre three-quarters of the breadth of the tread and around the circumference of the tyre.

Please refer to base vehicle manufacturer's handbook for tyre pressure information. This may also be displayed in the driver's door aperture.

DEDICATED TRAVELLING PASSENGER SEATING

Seat belts are fitted to all travelling seats. Travelling seats are designated by the manufacturer and vary according to the layout you have purchased. Each seat is homologated i.e. tested to all relevant safety requirements. NEVER travel in a non-designated seat.

WARNING: Side facing seats are designed for habitational use only, not when the vehicle is in motion.

SEAT BELTS AND LEGISLATION

Front Seats

The driver and front seat passenger in motorhomes must wear a seat belt, unless they have a medical exemption certificate.



Children, especially those under 3 years of age, must be restrained in a child seat suitable for their age.

NOTE: It is the legal responsibility of the driver to ensure that front seat passengers under the age of 14 years wear a seat belt.

Rear Seats

Children under the age of 14, travelling in the rear of a motorhome must use these restraints (unless they have a medical exemption certificate).

Children under 1 year old may be carried in a carrycot, provided the carrycot is restrained by straps.

Children under 12 years and under 150cm (4'11") in height must use a restraint, if a suitable one is available anywhere in the vehicle.

NOTE: Designated rear passenger seats are fitted with seat belts and must be worn.

It is the legal responsibility of the driver to ensure that passengers under the age of 14

years wear a seat belt. However, children are not required to be restrained in preference to adults.

Adults travelling in the rear must also wear seat belts. It is the responsibility of the adult passenger (not the driver) to ensure that they are using the seat belt.

THREE POINT SEAT BELTS

This section refers to the seat belts located in the habitation area of your motorhome.

Fastening the seat belt:

Insert tongue into buckle; a positive 'click' indicates correct assembly.

Releasing the seat belt:

Press the red release button, the tongue will be ejected from the buckle.

- The belt is designed for use by one person and must not be put around a child seated on a person's lap.
- The belt is suitable for restraining most child seats and boosters.
- The belt should at all times be adjusted and used in accordance with the instructions. No excessive slackness should be present.
- Once installed the diagonal should pass across the centre of the shoulder and the buckle should lie just on or below the hip.

- Avoid twisting the webbing during use. Webbing must not be allowed to chafe against sharp edges.
- Do not make alterations or additions to the belt.
- Belts that have been cut, frayed, damaged or stressed through impact should be replaced. After impact the motorhome anchorage points should also be checked.
- To clean use warm soapy water only.
- Periodic inspection of the installation will ensure reliability of the seat belt.

DRIVING LICENCE

Licences issued to drivers who passed their car driving test before 1st January 1997 include categories B+E and C1+E which gives them entitlement to drive motor vehicles up to 7500kg MTPLM.

Drivers who passed their test on or after this date have category B entitlement only, which restricts the entitlement to motor vehicles with up to 8 passenger seats and an MTPLM of up to 3500kg with trailers up to 750kg MTPLM (4250kg combined) or larger trailers providing the combination of the trailer and towing vehicle does not exceed 3500kg and the MTPLM of the trailer does not exceed the unladen weight of the towing vehicle.

Preparing for the Road

Drivers who passed their test on or after the 1st January 1997 will need to take an additional test(s) to gain the B+E and C1+E entitlement.

A number of Swift Group motorhomes have an MTPLM greater than 3500kg, therefore you must check you have the driving licence entitlement for the vehicle you drive.

VEHICLE CLASSIFICATIONS

Motorhomes up to 3500kg MTPLM are P/LGV (Private Light Goods Vehicles), motorhomes with an MTPLM over 3500kg and up to 7500kg are P/HGV (Private Heavy Goods Vehicles). These are used in defining MOT classifications and vehicle excise duty (road tax) classifications.

ADVICE ON TOWING

The towing capability of each motorhome differs depending on the specific chassis and engine types, (see 'Towing Capabilities Table' in your service handbook). This table takes account of the maximum front and rear axle loadings as well as the minimum front axle loading in two conditions, MRO and MTPLM condition.

Towing in these, and any other condition requires sensible loading & distribution of payloads to ensure the requirements of the towing capability table are met.

When towing, the demands on both the vehicle and driver increase. A trailer reduces manoeuvrability, the ability to climb hills, acceleration and braking capacity and makes the vehicle handle and corner differently. It will also increase the fuel consumption of the vehicle.

Always brake in good time. Special care must be taken when descending gradients. Change down before going down a steep hill so the engine can act as a brake. Ensure that the towing vehicle tyre pressures are correct and adjusted for full load conditions and that the trailer tyre pressures are as recommended by the trailer manufacturer. Regularly check the operation of trailer brakes and lights.

For maximum stability, when loading the trailer ensure that the loads are properly secured during transit. Position loads so that most of the weight is placed close to the floor and, where possible, immediately above or close to the axle(s). Where the load can be divided between trailer and tow vehicle, loading more weight into the vehicle will generally improve the stability of the combination. After loading the trailer, check that the nose weight and axle loads are in accordance with the manufacturer's recommendations, also check the rear and front axle loads on the motorhome. When calculating the laden weight of the trailer,

remember to include the weight of the trailer PLUS THE LOAD.

NOTE: Towing regulations vary from country to country to country. It is very important to ensure that national regulations governing towing weights and speed limits are observed (refer to the relevant national motoring organisation for information). The stated maximum permissible towing weights refer to the vehicle's design limitations and NOT to any specific territorial restrictions.

Notes:

- i) Do not exceed the motorhome gross vehicle train weight.
- ii) Do not exceed the maximum front & rear axle loads on the motorhome.
- iii) Ensure the motorhome front axle load is never less than 42% of the total weight.
- iv) Motorhomes with an MTPLM up to 3500kg which have European Type approval can only be fitted with a type approved towbar complying to EC/94/20.
- v) The limit for towing an un-braked trailer is 750kg (based on VIN plate not actual weight), this applies to a towed car.

- vi) A car dolly with a car with a GVW over 750kg in place is considered as two trailers, these are legal for use for recovery but under the Road Traffic Regulations Act 1984 the combination is limited to 40 mph on motorways and dual carriageways and 20 mph elsewhere. A car dolly is not legal for transportation (there is a very specific difference between recovery and transportation. Recovery is defined as the removal of a broken down vehicle to a place of safety).
- vii) The maximum permitted vehicle combination length is 18.75m, however any combination must ensure compliance with the turning circle requirements of Construction and Use regulations 1986 & 97/27/EC.

'EN ROUTE'

Spare Wheel Removal 14

'En Route'

REMOVAL OF SPARE WHEEL:

Caution: Exercise care when lowering the wheel and frame due to its weight.

Removal

- a) Spare wheel in the stowed position (Fig. 1).
- b) Remove the securing pins (a) from the supports (b) at each side of the spare wheel carrier frame (c) (Fig. 2).
- c) Lift the wheel carrier frame (c) slightly and move the frame supports (b) forward and clear of the carrier frame (Fig. 3).
- d) Lower the carrier frame and wheel to the ground (Fig. 4).
- e) Remove the spare wheel.

Replacement

Replacement is a reversal of the removal procedure.

Ensure the securing pins (a) are correctly located in the frame supports (b).

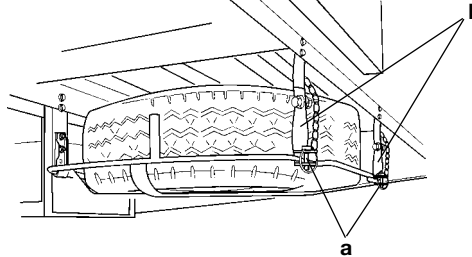

Fig.1

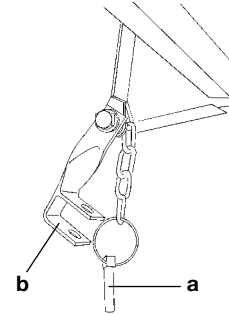

Fig.2

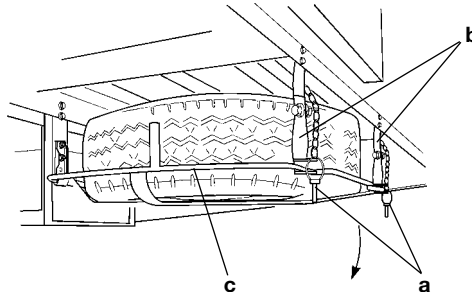

Fig.3

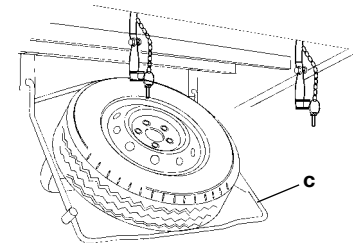

Fig.4

SAFETY & SECURITY

Fire	16
Ventilation	16
Escape Paths	16
Children	16
Security	16

Safety & Security

IMPORTANT: Your attention is drawn to the notice affixed in your motorhome advising you on fire prevention, ventilation and what to do in case of a fire.

FIRE

In case of fire

1. Get everyone out of the motorhome as quickly as possible using whichever exit is quickest including windows. Do not stop to collect any personal items.
2. Raise the alarm. Call the Fire Brigade.
3. Turn off gas supply valve, if safe to do so.

Fire Extinguishers

It is recommended that a 1kg (2lb) minimum capacity dry powder fire extinguisher complying with the requirements of ISO 7165 be carried inside your motorhome at all times and a fire blanket be kept next to the cooker.

A fat pan fire should not have an extinguisher aimed at it but be smothered with a fire blanket.

VENTILATION

All motorhomes comply with BS EN 721. The ventilation points on your motorhome are fixed points of ventilation which are required by the European Standards.

All motorhomes have ventilation at high level and low level which have been calculated to suit the individual needs of your motorhome.

High level ventilation is achieved by means of the roof lights and washroom roof ventilators. The low level ventilators are positioned underneath the oven housing. Some models in the doorway stepwell.

Under no circumstances must these vents be blocked or obstructed, even partially.

It is advised that fixed ventilation points are checked and cleaned (if necessary) on a regular basis using a small brush and a domestic vacuum cleaner.

Additional night time ventilation is obtained by releasing the window catches and placing them in the second groove. Note the windows are not sealed from rain in this position.

As the ventilation levels are calculated to suit each model's requirements there should be no modifications made which may result in reduced ventilation levels.

WARNING: Do not obstruct ventilation.

WARNING: Never use portable cooking or heating equipment other than electric heaters that are not of the direct radiant type, as it is a fire and asphyxiation hazard.

WARNING: Appliances such as cookers must not be used for heating.

ESCAPE PATHS

It is important that you do not block escape paths to emergency exits with obstructions or hazards.

CHILDREN

Do not leave children alone in the motorhome in any event. Keep potentially dangerous items out of reach, as at home eg matches, drugs etc.

SECURITY

Motorhome Theft

The theft of a motorhome can occur in the most unlikely circumstances; from a motorway service area or even an owner's driveway.

Secure all windows and doors when your motorhome is unoccupied even if only for a short length of time.

Chassis number

Record your motorhome chassis number, which can be found under the bonnet on the base vehicle chassis plate (Item D), and the body conversion serial number is an 'SGD' number found on the Swift Group serial plate.

Make a note of these numbers in the space provided at the rear of this handbook and make a separate note of the numbers to keep safe at home.

Additional security

Window etching of the chassis number is a cost effective deterrent.

Free crime prevention advice about securing your motorhome, protecting your valuables, property marking either at home or whilst on site, can be obtained from the Crime Prevention Officer through your local Police station.

MINDER SECURITY CHIPS

A special security chip is concealed within the body of every motorhome. This chip contains the individual identity of your motorhome and can only be read by using a special decoder. Your local police can obtain the use of a decoder by contacting MINDER on telephone no: 01722 435478.

Further inquiries concerning MINDER can also be made via email: minder.uk@hpi.co.uk

ARRIVAL AT SITE

Positioning the Motorhome	20
--	-----------

Arrival at Site

Note: Check and observe site regulations.

POSITIONING THE MOTORHOME

Keep to roadways unless otherwise directed. Adhere to speed limits. Note that these are generally 10mph.

(Remember that the stopping distance on grass is considerably greater than on tarmac.)

Only a person in possession of a current driving licence may drive on the site.

Selecting a pitch

Do not pitch in such a position that your motorhome will obstruct others coming in.

Try to choose an area which is dry, reasonably level and preferably with a hard base.

If you have no alternative but to pitch on a slope try to ensure that you are facing down the slope, for when you leave.

Levelling the motorhome

Levelling must be carried out in both directions for the refrigerator and other equipment to function correctly. Stepped levelling boards (Fig. B) or proprietary ramps are ideal for this purpose.

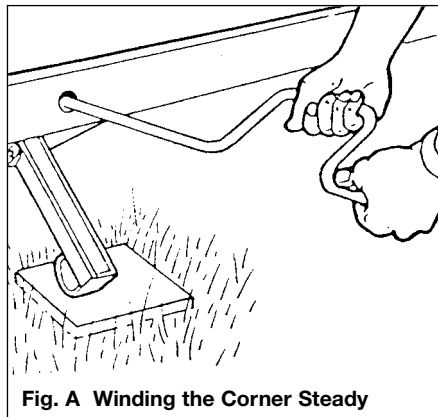

Fig. A Winding the Corner Steady

Lower the rear corner steadies (if fitted) until they are in firm contact with the ground (Fig. A). **DO NOT** use the steadies as a jack, they are only a means of stabilising the rear of the motorhome. Levelling pads or boards should be used under the steadies where the ground is soft or uneven.

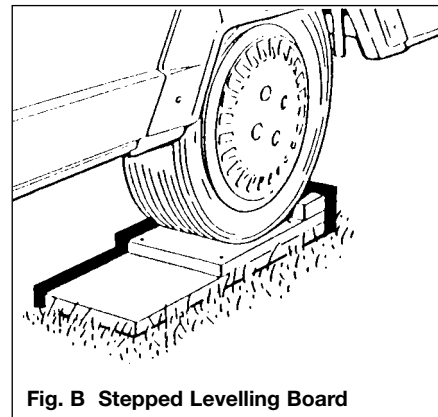

Fig. B Stepped Levelling Board

Awnings and Tents

Awnings and tents should only be used when permission has been obtained. When on grass and staying for more than a few days the ground sheet and/or side flaps of awnings should be periodically raised in order to avoid damage to the ground.

CONNECTING SERVICES

Water System	22
Guidance on Cleaning	24
Gas	26
Types of Gas	26
Safety Advice	27
Thermal Insulation and Heating	29
Electricity	30
Overseas Connection	31
Wiring Diagram	32
230V Mains Electrical Equipment Consumption	33

Connecting Services

Connection of services are dealt with under separate headings. In all cases become familiar with manufacturers' instructions.

Before making connections of any description to the motorhome ensure ALL equipment is turned off.

WATER SYSTEM

Fresh water system

- (i) All fittings, including the holding tank, water pipes, taps and connections are of food quality material (to BS6920) and therefore, should not affect the quality of the water used. It is recommended however, that the system is flushed through twice before it is used for the first time, and always cleaned/flushed after it has stood unused for a period of time (eg over the winter period). Care has been taken (using smooth bore pipes etc) to eliminate as many water traps as possible.
- (ii) When filling the fresh water system remember to check that the water source is suitable for use as drinking water and, if you are using a hosepipe or water carrier, that it is also made from non-toxic materials (preferably food quality material).
- (iii) The fresh water tank may be drained via a plug in the base of the tank, accessible via the cleaning hatch.
- (iv) The fresh water system is pressurised by a pump which will continue to operate until it senses a pre-set pressure in the system.

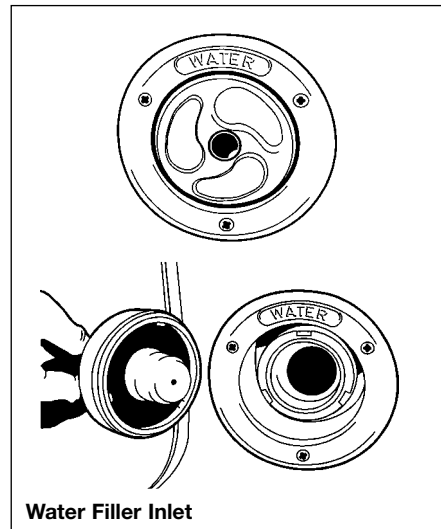
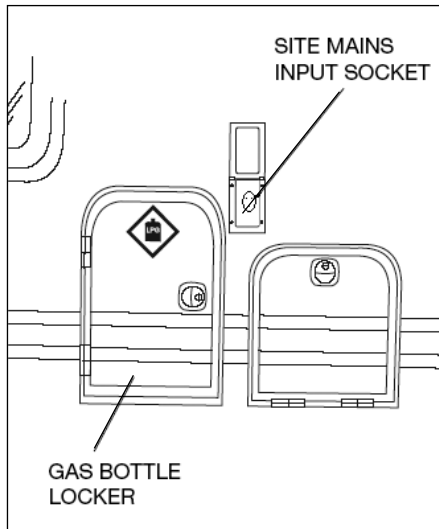

WARNING:
If the fresh water tank is completely empty the pump will be unable to pressurise the system and will operate continuously. In this situation it is essential that, in order to avoid damage to the pump, it is switched off using the pump isolator switch on the distribution panel until such time as the water tank has been filled.

Connecting Services

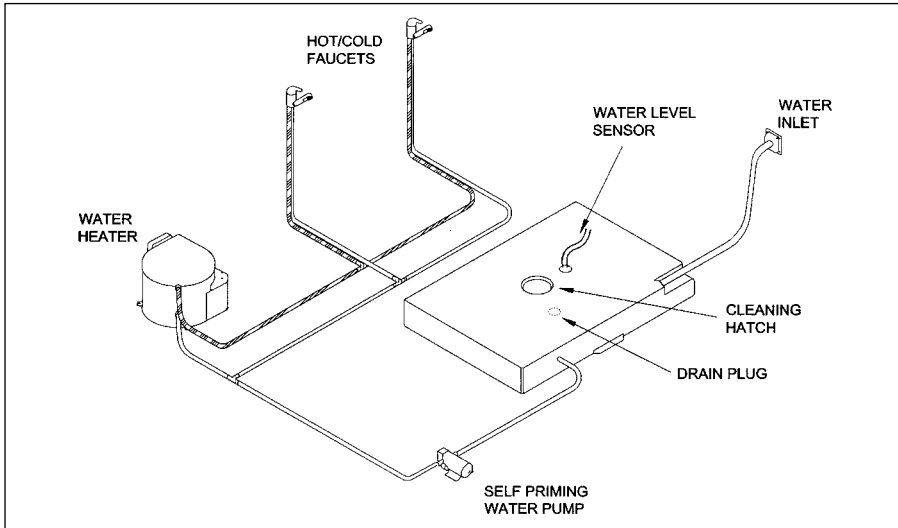

Waste water system

- (i) The waste water holding tank is secured underneath the chassis of your motorhome and is gravity fed.
- (ii) In order to eliminate unpleasant odours as much as possible, only smooth bore pipes are used. These are fitted with waste traps under the floor which should be cleaned periodically by unscrewing the lid and flushing with clean water. However, should the waste water tank be

overfilled, then the waste water will backfill the drain pipes until it eventually appears in the shower base. In order to prevent this, please take note of part (iii).

- (iii) The waste water gauge shows when the tank is full, not progressively and it is, therefore, recommended that the waste water tank is emptied on a daily basis. This is done by opening the valve located just beneath the side skirt on the exterior of the Motorhome or by turning

the handle located inside the vehicle at floor level behind the rear axle, usually found in bed box or wardrobe base (model dependant).

It should be emptied either directly, or via a waste water container (not supplied) into a designated waste water area.

Fresh Water Tank

Your motorhome is fitted with a water tank filled from the outside via a lockable water filler cap. When filling, use a hose manufactured from non toxic material, to prevent tainting of the water. Remember, if the water heater has been drained it will require 2.2 gal/ 10 litre or 2.6 gal/ 12 litre (dependant upon model) of water to fill it. To do this open all hot water taps (except shower) until water comes from the taps. Top up fresh water tank after priming the water system.

Please ensure all taps are fully turned off when not in use.

We recommend the use of Milton 2 sterilising fluid for cleaning and sterilising the water tank and system.

An explanatory leaflet is available from:
The Milton Food Hygiene Advisory Service,
Whitehall Lane, Egham, Surrey, TW20 9NW

Connecting Services

GUIDANCE ON CLEANING PORTABLE WATER TANKS AND THE WATER SYSTEM IN MOTORHOMES

The water systems, and in particular storage tanks, in motorhomes are susceptible to contamination by bacteria if care is not taken with their use and cleaning. The symptoms caused by bacterial contamination are not purely limited to gastro-intestinal diseases, but may also manifest themselves as ear, nose, throat, eye or skin infections. It is therefore important that you carry out the following procedure prior to using the motorhome each time, even if you boil or filter all water you use for drinking.

Separate Water Containers

1. All water remaining in the container should be disposed of so that the container is empty.
2. The outside of the container should be thoroughly cleansed and washed down to remove any dirt, dust or other contaminant. Water at a suitably hot temperature containing an appropriate detergent is recommended for this purpose.
3. Water should be put in the container, swirled around, then emptied out.
4. The container should then be totally filled with water containing an appropriate sterilant solution and allowed to stand for the recommended contact time (eg Milton for 15 minutes).
5. The solution should be emptied from the container.
6. The opening of the container should be cleaned thoroughly with an appropriate prepared wipe impregnated with a sterilant.
7. The container should be inverted whilst stored overnight (if possible).
8. The container must be filled with mains water only and mains water only should be used for the above cleaning procedure.
9. On no account should garden hoses be used to fill water tanks.

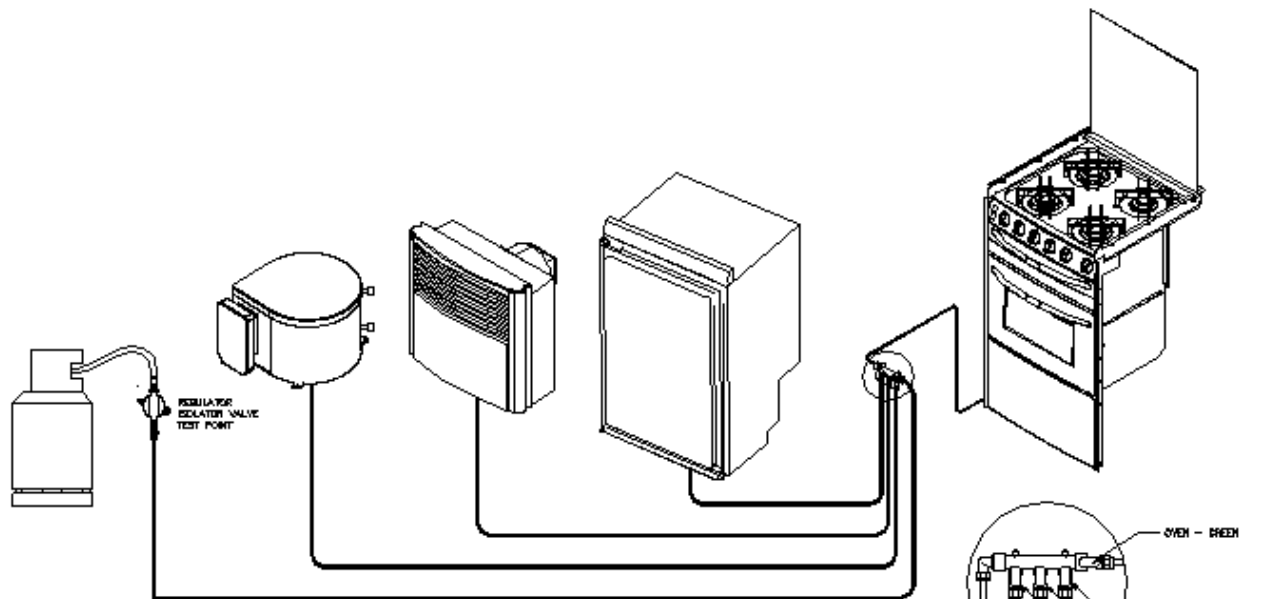

THE ABOVE SCHEMATIC IS ONLY A REPRESENTATION,
APPLIANCES MAY VARY TO THOSE FITTED TO YOUR VEHICLE

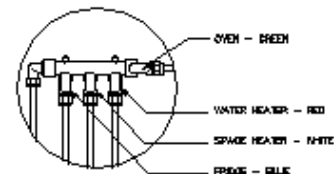

Typical gas
schematic drawing

Connecting Services

GAS

GENERAL INFORMATION

Gas Bottles

Bottled Liquefied Petroleum Gas (LPG) is the most convenient portable source of fuel for your motorhome.

Make sure that heating and cooking appliances and the gas cylinders are switched off before you move the motorhome.

Regularly check flexible gas hose, joints and connections for tightness. Finally make sure that each gas appliance is working efficiently to the recommendations of the appliance manufacturers.

Only use gas bottle cylinders that are located within their dedicated position within the gas bottle housing, never extend hose - hose lengths must not exceed 400mm.

Regulator

Your motorhome is supplied with a wall mounted gas regulator plumbed inside the gas bottle compartment. The regulator and all appliances work at a harmonised 30mbar pressure, which work with Butane and Propane gas.

Pressure regulation system in this vehicle has a fixed working pressure of 30 mbar with a flow rate of 1.5 kg/h and complies with the requirements of EN 12864 annex D.

Note: Regulator valves should always be in the 'OFF' position when driving.



Gas Hoses

Two new hoses, or pigtailed as they are being called, are available - one for Propane and one for Butane with adaptors for Butane 'clip-on' and Camping Gaz cylinders. It is important to check you have the correct hose and adaptor to suit your gas bottles. Push on hoses are no longer permitted under the new regulations, the new hose have threaded connections and must be securely attached to the regulator and to the gas bottle.

WARNING: Inspect flexible gas hose(s) regularly for deterioration and renew, as necessary, with the approved type, in any case no later than the expiration date marked on the hose(s).

WARNING: Ensure hoses do not become entangled in door mechanism.

TYPES OF GAS

Butane

Butane is supplied in the UK in green, blue or aluminium bottles.

All these have a male left hand thread EXCEPT for Camping Gaz which has a special female right hand thread and Calor 7kg and 15kg and aluminium bottles which have a special clip-on connection.

Continental bottles usually have a male left hand thread similar to but not identical with UK butane.

Butane is suitable for use at temperatures down to 2°C but will not work below that.

Propane

Propane is supplied in red, or partly red bottles which have a female left hand threaded connector.

Scandinavian countries use the same connector.

Connecting Services

Germany and Austria supply propane with a male connection.

Propane will work at temperatures as low as -40°C and is therefore suitable for all winter caravanning.

GAS SAFETY ADVICE

WARNING: If you smell gas or suspect a leak and if it is safe to do so, isolate the gas appliances and turn off the gas bottles at the regulator. Evacuate the caravan and ventilate. Seek professional advice as to the cause of the leak.

Facts about LPG

LPG is not poisonous.

Bi-products are harmless.

There is danger if all air and oxygen were excluded.

(Ventilation holes must be kept clear at all times).

LPG has been given a smell by the manufacturers in order to identify leaks.

Awning Spaces LPG Appliance Exhaust

There is no danger of pollution of an enclosed awning space by the LPG exhaust from a refrigerator venting into it, as awning spaces are generally well ventilated.

Space heaters may produce sufficient

exhaust to pollute the awning space, if it is totally enclosed, from a general comfort, smell and hygiene point of view. In the extreme case there could be a build up of carbon dioxide to a dangerous level.

Owners are advised to allow some fresh air circulation in the awning space when such appliances are in use.

PRECAUTIONS

- a) Never look for a leak with a match. Always use a soap solution or its equivalent when testing connections. Do not operate any electrical apparatus whatsoever, especially light switches. If the leak is not obvious, the motorhome should be evacuated and qualified personnel consulted.
- b) Always turn off the gas cylinder valve or inlet to the motorhome when the appliances are not in use.
- c) Never use gas appliances without adequate ventilation.
- d) Avoid naked lights when connecting or changing a cylinder.
- e) Check the flexible hose frequently.
- f) The gas is heavier than air and therefore sinks to the lowest point.
- g) Keep bottle gas containers outside (and protected against frost). If they must be kept inside make sure they are well away from heat.

- h) Always seek advice when in doubt.

WARNING: Do not use appliances with a different working pressure to 30mbar.

WARNING: Maintain adequate spacing of combustible materials from sources of heat.

WARNING: Do not use independent portable gas appliances inside the vehicle.

Always read individual appliance instructions

VENTILATION

All ventilation complies with BSEN 721 and vents should not be obstructed in any manner as this could lead to insufficient fresh air. In this case the confined atmosphere becomes depleted of oxygen which leads to the formation of the highly poisonous gas 'carbon monoxide'. Carbon monoxide is odourless, colourless and tasteless and will rapidly cause unconsciousness and death with little or no warning prior to collapse. THERE IS NO DANGER WHEN ADEQUATE VENTILATION IS PROVIDED.

Connecting Services

Roof-mounted flue installations

All flue installations should be inspected once a year throughout their length for corrosion. Flues should be replaced if any sign of perforation is found. Ensure that the replacement is of an approved type.

CHANGING GAS CYLINDERS

The following procedure should be adopted:

- a) Extinguish any fire, flame or source of ignition (including cigarettes, pipes and pilot lights) before changing gas cylinders.
- b) Wherever possible change gas cylinders in the open air.
- c) Ensure that the gas cylinder valve(s) is/are closed before disconnecting any empty cylinder or before removing the plastics cap or plug on the outlet connection of the replacement cylinder. (Note. left hand thread.)
- d) Make firm gas-tight joints. Any leaking vapour will smell. If a leak is suspected after changing gas cylinders and opening valve, test by brushing with soapy water around the joints. Bubbles will form if vapour is leaking. **Never use a naked flame.**
- e) Ensure that the replacement gas cylinder is the correct one for the installation.

- f) Gas cylinder valves are of various designs depending on the type of cylinder and the use for which it is intended and it is essential that the correct pressure regulator with the correct pressure setting and capacity for the installation is used in accordance with manufacturer's instructions.
- g) In the case of a connection on the pressure regulator which relies upon a sealing washer(s) to maintain a gas-tight joint, it is essential to check that the washer is present, is sound and is correctly positioned prior to making the connection. Where the connection relies on a metal to metal seating or bull nose connection to obtain a gas-tight joint it is essential that the mating surfaces are clean and undamaged. In no case should a damaged valve or connection be used.
- h) The connections are designed to be tightened with a spanner. It is essential that a spanner of the correct size is used and that the union is firmly tightened, hand tightness is not sufficient. When self-sealing valves are incorporated in a gas cylinder, connections should be made in accordance with the manufacturer's instructions and tools should not be used.

LEAKS

Action to be taken in the event of a suspected leak:

- a) If a gas leak is suspected, close the gas cylinder valve or other valve at the inlet to the motorhome. Do not operate electrical switches. Open all doors and windows to disperse any gas escape.
- b) The strong unpleasant smell of LPG will enable the general area of the leak to be detected. Check that gas is not escaping from an unlit appliance. In the case of a leak, close cylinder valve(s) and call a competent installer to rectify the fault.
- c) If a leaking gas cylinder cannot be stopped, remove the cylinder to a safe place in the open air in an upright position away from drains and any source of ignition.

FIRE

Precautions and actions to be taken:

- a) A fire extinguisher of adequate size and preferably of the dry powder type should be available.
- b) The initial use of dry powder extinguishers is recommended only if it likely that the leakage can be stopped by closing the cylinder valve or that the cylinder can be speedily removed.

Connecting Services

- c) Cool with water all gas cylinders that cannot be removed.
- d) As soon as possible remove cylinders adjacent to the fire to safe place in order to gain access to the seat of the fire.

CONNECTION

Ensure that the gas regulator hose is correctly connected to the gas cylinder in gas bottle compartment and that the hose connection is tight.

Gas bottles must be fully located, seated at the base of the bottles and restrained by the strap provided in the dedicated compartment position.

Straps are positioned to suit 6kg, 7 kg and 13kg bottles.

WARNING: If using cylinders other than those recommended, the user must ensure these are adequately supported, ventilation openings must not be obstructed and the cylinders must not cause damage to other fixtures and fittings located in the compartment.

Open ended gas hoses must always be protected from dirt and insects.

Before turning on the gas supply at the regulator, ensure that all gas operated equipment in the motorhome is turned off.

All gas equipment is supplied through a central Gas Manifold System which has individual isolation taps for each appliance (Fig A), as follows:

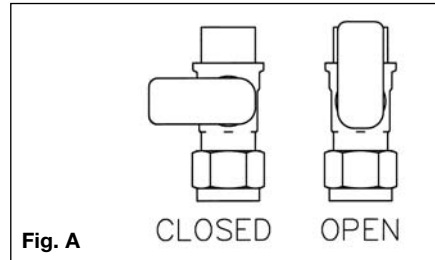

RED	-	Water Heater/ Combination Boiler
WHITE	-	Space Heater
BLUE	-	Fridge
GREEN	-	Oven

THERMAL INSULATION HEATING

Your motorhome has been designed to achieve a thermal insulation and heating level for specific climatic conditions when tested according to the procedure in EN1646-1. The classifications are as follows:

GRADE 1

A motorhome with an average thermal transmittance (u) that does not exceed $1.7w/(m^2k)$.

GRADE 2

A motorhome with an average thermal transmittance (u) that does not exceed $1.7w/(m^2k)$ and which can achieve an average temperature difference of at least 20k between inside and outside temperatures when the outside temperature is $0^{\circ}C$.

GRADE 3

A motorhome with an average thermal transmittance (u) that does not exceed $1.2w/(m^2k)$ and which can achieve an average temperature difference of at least 35k between inside and outside temperatures when the outside temperature is $-15^{\circ}C$.

Connecting Services

ELECTRICITY

As with electricity in the home, care must be exercised when handling mains electricity.

Your attention is drawn to the following notice as laid down by the Institute of Electrical Engineers.

INSTRUCTIONS FOR ELECTRICITY SUPPLY

On arrival at site

1. Before connecting the motorhome installation to the mains supply, check that:
 - (a) the mains supply is suitable for your installation and appliances, ie whether it is AC or DC and whether it is at the correct voltage and frequency, and
 - (b) your installation will be properly earthed. Never accept a supply from a socket outlet or plug having only two pins, or from a lighting outlet.
 - (c) any residual current device (earth leakage circuit breaker) in the mains supply to the motorhome has been tested within the last month.

In case of doubt, consult the site owner or his agent.

2. MAKE SURE THAT THE SWITCH AT THE SITE SUPPLY POINT IS OFF.
3. Lift the cover of the electricity inlet provided on the motorhome, and insert the connector of the supply flexible cable.
4. Remove any cover from the socket outlet provided at the site supply point, and connect the plug at the other end of the supply flexible cable to this. Switch on the main switch at the site supply point.

On leaving site

5. Switch off the main switch at the site supply point and remove the flexible cable connector replacing any cover fitted.
6. Disconnect the flexible cable from the motorhome.

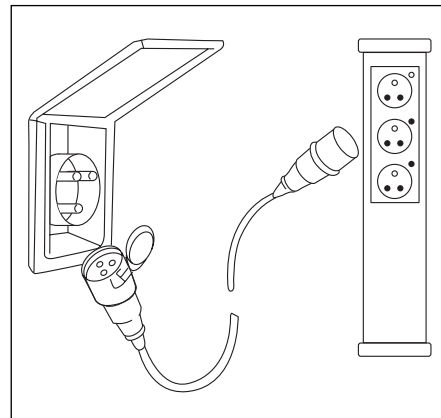

IT IS IMPORTANT THAT THE MAIN SWITCH AT THE SITE SUPPLY POINT SHOULD BE SWITCHED OFF, THE SUPPLY FLEXIBLE CABLE DISCONNECTED, AND ANY COVER REPLACED ON THE SOCKET OUTLET AT THE SITE SUPPLY POINT BEFORE DISCONNECTING THE FLEXIBLE CABLE FROM THE MOTORHOME. IT IS DANGEROUS TO LEAVE THE SUPPLY SOCKET OR SUPPLY FLEXIBLE CABLE LIVE.

For motorhomes that are generally left unused for long periods in the open it is strongly advised that the mains installation is inspected periodically to ensure that it is safe to use. The IEE Wiring Regulations recommend that mains installations in motorhomes are re-inspected every 3 years. An annual inspection by a qualified person is recommended (see list below) who should sign and issue a periodic inspection report.

Suitably qualified persons acceptable to the SMMT/NCC to sign and issue Inspection and Completion Certificates should be one of the following:

- An approved contractor of the National Inspection Council for Electrical Installation Contracting* or
- A member of the Electrical Contractors' Association of Scotland
- A qualified person acting on behalf of the above (in which event it should be stated for whom he is acting).
- The names and addresses of Approved Contractors in any locality (there are over 10,500 in the UK) can be obtained from Electricity Shops, or direct from:

NICEIC
Vintage House
37 Albert Embankment
London SE1 7UJ
Telephone: 0207 564 2323

The names and addresses of members of the Electrical Contractors' Associations can be obtained direct from:

ECA
Esca House
Palace Court
London W2 4HY
Telephone: 0207 313 4800

ECA of Scotland
23 Heriot Row
Edinburgh EH3 6EW
Telephone: 0131 225 7221

IN CASE OF DIFFICULTY CONSULT AN APPROVED ELECTRICAL INSTALLATION CONTRACTOR (WHO MAY BE THE LOCAL ELECTRICITY COMPANY). IT IS DANGEROUS TO ATTEMPT MODIFICATIONS AND ADDITIONS YOURSELF. LAMPHOLDER-PLUGS (BAYONET CAP ADAPTORS) SHOULD NOT BE USED IN ANY CIRCUMSTANCES.

OVERSEAS CONNECTION

Note: Connection to a mains voltage supply OVERSEAS requires particular attention.

Care must be taken when connecting supplies abroad since the supplies can be of REVERSE POLARITY.

The significance of REVERSE POLARITY is that when equipment is switched off it may not be electrically isolated.

The only certain way of making equipment safe is to unplug it.

If electrical polarity indication is not included in your motorhome electrical equipment, it is useful to have a means of checking polarity of the mains supply, especially when touring overseas.

There are several proprietary makes of equipment available for the purpose.

If it can be achieved, it is preferable to connect live to live, and neutral to neutral to maintain full electrical protection.

CHECK all motorhome equipment is set-up to accept the site supply before actually switching on.

WIRING OF CONNECTING CABLE AND MOTORHOME MAINS INLET

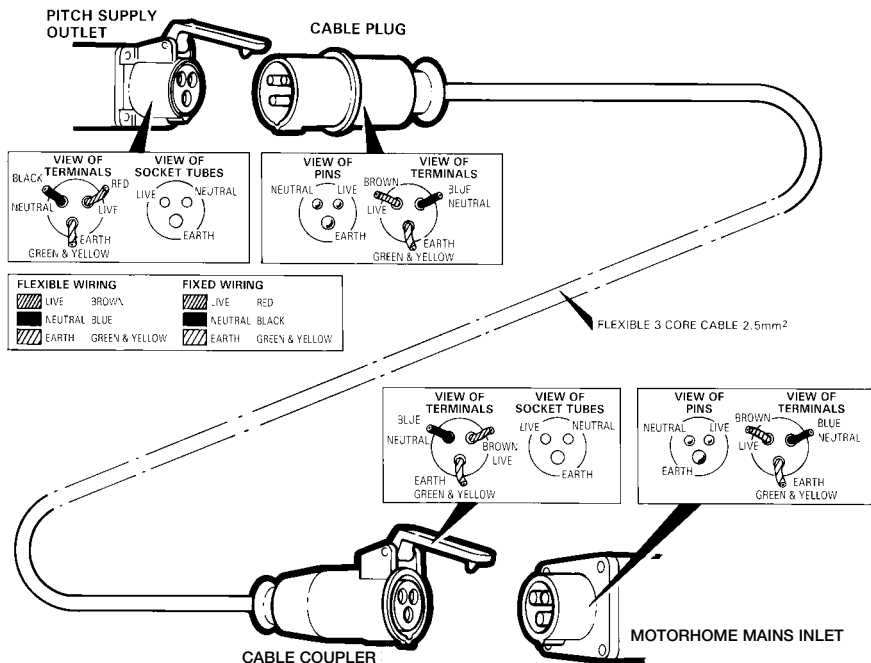

WARNING

IT IS ESSENTIAL THAT CONNECTIONS ARE MADE EXACTLY AS SHOWN. IF TERMINAL MARKINGS ARE NOT IN ACCORDANCE WITH THE DIAGRAM THEY MUST BE IGNORED. IF IN DOUBT CONSULT A QUALIFIED ELECTRICIAN. THE LEGAL MAXIMUM LENGTH OF THE MAINS INLET CABLE IS 25 METRES. WHEN IN USE IT MUST BE FULLY UNCOILED.

230V MAINS ELECTRICAL EQUIPMENT POWER CONSUMPTION

Please note:

It is possible that the 230V mains electrical equipment may not all operate simultaneously. A typical UK motorhome site mains hook up point provides a maximum output of 10 amps and on some continental sites the available output may be as low as 5 amps. If your loading exceeds the site supply it may trip the site circuit breaker. Please check the available mains output with your site operator.

Similarly loadings on each circuit breaker within the motorhome should be observed – See MCB label

WARNING: Never allow modifications of electrical or LPG systems and appliances except by qualified persons.

Connecting Services

TYPICAL APPLIANCE CONSUMPTION FIGURES

Appliance/ Item	230 Volt		12 Volt		LP Gas	
	Watts	Amperes	Watts	Amperes	grams/hour	
Refrigerator RM 7360, RM 7361	115 W	0.5 amp	120 W	10 amp	12 g/h	
Refrigerator RM 7405, RM 7605	135 W	0.6 amp	3.5 W / 175 W	0.05 amp / 14.6 amp	16 g/h	
Ultraheat Space Heater	500 W	2.2 amp	12 W	1.0 amp	30 to 280 g/h	
	1000 W	4.3 amp	12 W			
	2000 W	8.5 amp	12 W			
Ultrastore Water heater	850 W	3.7 amp	Not applicable		120 g/h	
Comination Boiler	1800 W	7.8 amp	71W	5.9 amp	170 - 490 g/h	
Cooker	Hotplate 1	Not applicable		Not applicable	161 g/h	
	Hotplate 2	Not applicable		Not applicable	110 g/h	
	Hotplate 3	Not applicable		Not applicable	73 g/h	
	Hotplate 4	800 W	3.5 amp	Not applicable	Not applicable	
Grill	Not applicable		Not applicable	Not applicable	117 g/h	
Oven	Not applicable		Not applicable	Not applicable	125 g/h	
Battery Charger	725 W	3.15 amp	Not applicable		Not applicable	
Lighting 12V (based on 10 W bulb)	Not applicable		10 W	0.8 amp	Not applicable	
Shur-flo water pump	Not applicable		20 W	1.6 amp	Not applicable	
Radio/ CD player	Not applicable		12 W	1.0 amp	Not applicable	
Omnivent	position 1	Not applicable		15 W	1.2 amp	Not applicable
	position 2	Not applicable		30 W	2.5 amp	Not applicable
	position 3	Not applicable		50 W	4.0 amp	Not applicable
Air Conditioning unit	1.21 W	5.2 amp	Not applicable		Not applicable	
Sharp Microwave (factory fit)	1200 W	5.3 amp	Not applicable		Not applicable	
Daewoo Microwave (factory fit)	1000 W	4.3 amp	Not applicable		Not applicable	

Note: These are approximate figures for guidance only.

ELECTRICAL SYSTEMS

Motorhome Battery	34
Fault Finding	34
Mains Unit	35
12V Power System	36
Transformer/Charger Unit	36
The EC200 Electronic Control System	37
System overview	37
Power supply unit - System operation	37
Control panel operation	42
Technical data and approvals	46
AC85 Power Control	47
Generator Guidelines	48

Electrical Systems

MOTORHOME BATTERY

It is recommended that a good quality leisure battery is always in circuit when the system is in use.

A deep cycling rechargeable heavy duty 12v battery should be used to provide power for lights and other electrical appliances.

A proprietary brand leisure battery with a minimum 85amp - 110 amp capacity is recommended.

Note: 85amp - 110 amp batteries and above should be checked dimensionally before purchasing, to ensure fitment within the battery compartment, as brands vary in size.

It should be remembered that batteries suitable for the electrical demands of a motorhome differ in design from those for use with a car, and whilst the system may operate with a car battery it is strongly recommended that only a rechargeable leisure type battery, maintained in good condition is used. The battery should be kept topped up at all times.

The battery should be positioned in its compartment, which is vented to the outside, and be properly secured before travelling.

WARNING: Ensure the battery venting kit is correctly fitted and unobstructed.

WARNING: When connecting the battery, ensure that the correct polarity is observed (black is negative and red is positive) and that the terminals are securely fastened.

Under normal circumstances it should not be necessary to remove the battery other than for routine inspection of terminals and “topping up”.

WARNING: Explosive gases may be present at the battery. Take care to prevent flames and sparks in the vicinity.

Your motorhome has been fitted with an in-line fuse between the battery terminal and strip connector. It is recommended that the fuse rating fitted in this location does not exceed 20 amps.

WARNING: Switch off all appliances and lamps before connecting or disconnecting the battery.

Smoking is prohibited around the battery compartment.

To preserve the life of your leisure battery and charger please observe the following:

- i) Do not leave all 12v lights powered at the same time as this will drain your leisure battery more rapidly.

- ii) If all 12v lights must be powered together, ensure the battery is 'in-circuit' ie selector switch in the 'van' position and that the battery charger is turned on.
- iii) For optimum performance use the transformer/charger unit with a leisure battery attached.

Please note the auxilliary battery supplied with your motorhome may not be fully charged and should be charged for a minimum of 24 hours before use.

FAULT FINDING

1. Mains supply

If mains supply is not available when mains switch and MCBs are switched on, check supply at site distribution and/or mains lead and connections.

2. Earth faults or MCB tripped

See RCD/MCD Section.

3. Charger switch fails to illuminate

Check mains supply as for No.1 and 2.

4. Battery discharged or not charging with charger on

Check battery terminals.

5. 12V distribution circuit failure

Check and replace relevant DC output fuse as required.

6. Consult the manufacturers regarding any further difficulties, in particular those related to mains voltage section.

7. There are no user-serviceable or replacement parts in the consumer unit. All service of this nature should be referred to the manufacturers.

Note: Never use a mains supply lead whilst coiled. Always uncoil the full length before connecting to the supply and remember to protect the cable from traffic.

SOLAR PANEL CONNECTION POINT

A connection point has been included in the motorhome electrical harness to take a 12v supply from an aftermarket solar panel (or similar device), to the motorhome leisure battery. The supply is direct to this battery, and so is not isolated / controlled by the habitation area control panel. The solar connection point does not provide charge to the vehicle engine / traction battery.

The solar panel must provide a fused and regulated output in order to connect to this point. The connection point can be found in the wardrobe area, in close proximity to the charger / Fuse box.

A kit of parts is available from your caravan supplier which provides the mating half of the connection point. (The White rectangular connector found inside the motorhome is a two way JST-LP type connector). For further assistance in identifying the connection, wire colours leading to the connector are detailed in the wiring schematic in your motorhome service book.

MAINS UNIT

This acts as the main switch for the motorhome allowing isolation of all circuits. It forms part of the Power System along with the Transformer/Charger Unit (if fitted).

The mains unit replaces the conventional fusebox. Similar, but larger ones are often fitted in new houses.

The unit gives both overload (MCBs) and earth leakage protection (RCD) for the electrical supply in your motorhome.

For normal operation all switches on the unit need to be in the ON position. The small switches on the unit are known as MCBs (miniature circuit breakers).

These take the place of the conventional fuse but are more convenient.

Note: Having too many appliances switched on at the same time will trip the MCBs. This is a safety measure. (For appliance ratings, see mains consumption, right).

In the event of a fault the MCB 'trips' ie automatically moves to the OFF position.

After elimination of the fault the MCB can be re-set by switching to the ON position, (against the spring pressure in an upwards direction).

If an earth fault develops or a person touches a live piece of equipment the leakage of current to earth should immediately operate

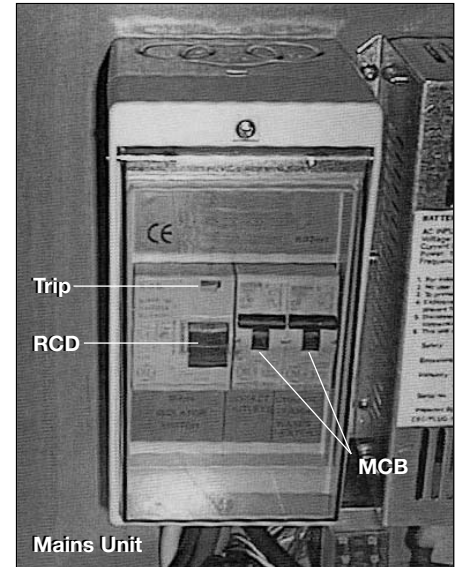

the RCD (residual current device) and 'trip' the main switch, to the OFF position.

This switch is only re-settable after elimination of the fault.

To re-set, operate the switch as for MCBs.

Periodically the RCD should be checked by operating the test button marked 'T'. The unit should immediately switch to the OFF position. If the unit does not switch off then a qualified electrician should be consulted.

Electrical Systems

If the unit does switch off, the test is complete and the switch can be re-set restoring the supply back to normal.

Add together the current ratings for each electrical appliance you wish to use simultaneously and ensure the total does not exceed 10A. You will find the following table a useful guide to typical values.

230V MAINS CONSUMPTION

FRIDGE	0.5A
CHARGER	1A
ULTRASTORE WATER HEATER (where fitted)	3.75A
ULTRASTORE SPACE HEATER (where fitted)	8.75A
COMBI EH (where fitted)	3.9A/7.8A

Formula for calculating current consumption of appliances:

$$\frac{\text{Watts}}{\text{Volts}} = \text{Amps}$$

12V POWER SYSTEM

Note: The connection of the battery charger to the mains supply is in accordance with the Regulations for Electrical Installations 16th Edition (IEE Wiring Regulations) BS 7671: 1992.

The Power System is supplied fitted in a convenient position and comprises:

- (a) Mains Unit
- (b) Transformer/Charger Unit
- (c) Combined mains unit + transformer/charger (Kon-Tiki/ E700 series)

TRANSFORMER/CHARGER UNIT

The transformer/charger unit has important safety features:

- Overload protection
- Short circuit protection
- Reverse battery polarity protection

The unit has been designed not only to operate as a battery charger, but also for use as a power supply, should a 12V DC battery not be present in circuit. It is, however, recommended that a good quality leisure battery is installed.

Once connected to a 230V mains supply and switched on, its operation is fully automatic.

When used as an alternative DC power supply, with no battery in circuit, the unit will supply a suitable output for use with pump, lighting, TV, radio etc.

The facility for drawing 12V supply from the cab battery is intended for standby situations only, and care should be taken not to run the cab battery too low, some models feature cab battery protection circuitry.



Charger/Transformer

If the cab battery has been used on site, then the engine driven alternator will recharge both it and the leisure battery whilst travelling.

However, once the cab battery is fully charged, the alternator will supply a trickle charge only to the caravan battery.

This will take place regardless of the position of the battery selector switch on the distribution panel.

1. INTRODUCING THE EC200 ELECTRONIC CONTROL SYSTEM

With the use of new technology and an innovative approach to user interfacing, the EC200 Power Control System provides a complete control solution for a wide range of leisure vehicles.

The microprocessor controlled digital system allows the user to control equipment and view / edit system information from a user-friendly control panel that incorporates a liquid crystal 'ALPHA-NUMERIC' display.

The built in 'intelligence' prevents over discharge of the vehicle battery, allows greater control of the water system and has a built in alarm clock. With the addition of an optional plug-in remote control pack the Power and Auxiliary functions can be operated by a key fob controller.

The system meets relevant UK legislation, including the requirements of BS7671, EN1648-1 and -2. Further technical data is contained in section 5.

2. SYSTEM OVERVIEW

The following diagram shows the components that make-up the EC200 system. The system basically comprises a Power Supply and Control Unit (PSU2007) that houses the Mains 240v protection equipment, a 200 watt 12v charger / power

supply, and power control / protection for the 12v equipment. The PSU2007 is connected to a Digital Control Panel via a data cable.

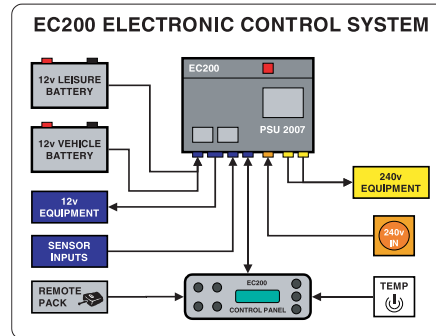

3. POWER SUPPLY UNIT – SYSTEM OPERATION

3.1 INTRODUCTION

For the safe operation of all electrical equipment within your Leisure Vehicle it is important that you read and fully understand these instructions. If you are unsure of any point please contact your dealer / distributor for advice before use.

The following diagram shows the PSU2007 layout.

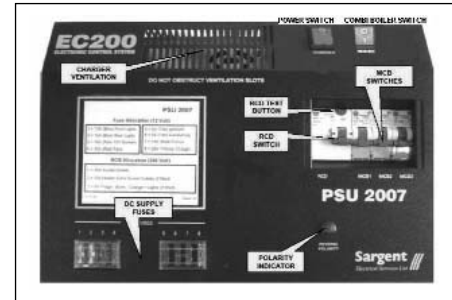

WARNING: Under heavy loads the PSU2007 case will become hot.

ALWAYS ensure the ventilation slots have a clear flow of air. Do not place combustible materials against / adjacent to the PSU2007. The PSU will shutdown if overheated and will restart automatically when cool

3.2 MAINS CONNECTION

For your safety it is IMPORTANT that you follow these connections instructions each time your Leisure Vehicle is connected to a mains supply.

- a) **Ensure suitability of the Mains Supply.** Your Leisure Vehicle should only be connected to an approved supply that meets the requirements of BS7671. In most cases the site warden will hold

Electrical Systems

information regarding suitability of supply. If using a generator you also need to comply with the requirements / instructions supplied with the generator.

- b) **Switch the PSU2007 internal Charger unit OFF.** Locate the red 'Charger' power switch on the PSU2007 and ensure the switch is in the OFF (0) position before connection to the mains supply.
- c) **Connect the Hook-up Lead.** Firstly connect the supplied hook-up lead (orange cable with blue connectors) to the Leisure Vehicle and then connect to the mains supply.
- d) **Check Residual Current Device operation.** Locate the RCD within the PSU2007 and ensure the RCD is switched on (lever in up position). Press the 'TEST' button and confirm that the RCD is turned off (lever in down position). Switch the RCD back to the on position (lever in up position). If the test button failed to operate the RCD see section 3.4.
- e) **Check correct Polarity.** Locate the 'Reverse Polarity' indicator on the PSU2007 and ensure that the indicator is NOT illuminated. If the indicator is illuminated see section 3.4.
- f) **Check Miniature Circuit Breakers.** Locate the MCBs within the PSU2007 (adjacent to the RCD) and ensure they are

all in the ON (up) position. If any MCBs fail to latch in the on position see section 3.4.

- g) **Turn the PSU2007 ON.** Locate the red power switch on the PSU2007 and turn to the ON (I) position. The switch will illuminate when turned on.
- h) **Check operation of equipment.** It is now safe to check the operation of the 12v and 240v equipment.

3.3 BATTERY

a) Type / Selection

For optimum performance and safety it is essential that only a proprietary rechargeable brand LEISURE battery is used with a typical capacity of 75 to 120 Ah (Ampere / hours). A normal car battery is NOT suitable.

It is recommended that the leisure battery is always 'in circuit' when the system is in use.

The battery feed is fitted with an inline fuse between the battery and the electrical harness, and is usually located immediately outside the battery compartment or within 500mm of the battery. The maximum rating of this fuse is 20A.

b) Installation & Removal

Always disconnect the 240v mains supply and turn the PSU 2007 charger switch to the OFF (0) position before removing or installing

the battery.

When connecting the battery, ensure that the correct polarity is observed (black is negative [-] and red is positive [+]) and that the terminals are securely fastened. Crocodile clips must not be used.

WARNING: Explosive gases may be present at the battery. Take care to prevent flames and sparks in the vicinity of the battery and do not smoke.

c) Servicing

Under normal circumstances it should not be necessary to remove the battery other than for routine inspection of the terminals and "topping up" of the battery fluid where applicable. Please see instructions supplied with the battery.

Note: Do not over-discharge the battery. One of the most common causes of battery failure is when the battery is discharged below the recommended level of approximately 10.5v. Discharging a battery below this figure can cause permanent damage to one or more of the cells within the battery.

3.4 FAULT TABLE

Fault	Possible Cause	Proposed Fix
No 240 volt output	Connecting lead between the site and Leisure Vehicle not connected	Check and connect lead as per 3.2.C Check also input connector at the base of the PSU 2007
	RCD switched off	Reset RCD as per 3.2.D
	RCD not operating correctly	Check supply polarity; if the RCD continues to fail contact your Dealer, as there is probably a wiring or equipment fault.
	MCB switched off	Reset MCB by switching OFF (down position) then back ON (up position), if the MCB continues to fail contact your Dealer, as there is probably a wiring or equipment fault.
	No or deficient supply from site	Contact site Warden for assistance
	Other fault	Contact your Dealer
No 12 volt output	No 240v supply	Check all above
	Charger not switched on	Switch charger switch on (I) position, switch will illuminate
	Battery not connected and / or charged	Install charged battery as per 3.3.B
	Power switch on control panel not switched to ON	Turn power on at control panel
	Battery flat / Battery fuse blown	Recharge battery, check fuses, check charging voltage is present at battery
	Fuse blown	Check all fuses are intact and the correct value fuse is installed as per fuse table shown in 3.5

Electrical Systems

Fault	Possible Cause	Proposed Fix
No 12 volt output	Equipment switched off / unplugged	Check equipment is switched on and connected to the 12v supply
	Other fault	Contact your Dealer
Control Panel Problems	Control Panel has no display	<p>Check batteries, turn PSU2007 charger switch on, and ensure mains supply is connected.</p> <p>Check control panel connecting lead at PSU2007 and behind Control Panel</p> <p>Contact your Dealer</p>
	12v Power turns off	<p>Battery save feature has operated to protect the Vehicle battery and the Leisure battery is flat (see section 4.4)</p> <p>Engine has been started, all equipment has been disconnected to meet EMC requirements</p>
	Control Panel display corrupt / erratic function	<p>Observe control panel handling instructions</p> <p>Reboot control panel by removing control panel bezel, removing two fixing screws, and unplugging the control panel connecting lead. Wait 30 seconds then reconnect and re assemble.</p>
	Control Panel contrast poor	<p>Observe control panel handling instructions</p> <p>Remove control panel as above but do not unplug. Adjust contrast preset on back of control panel using jewellers screwdriver</p>
	Control Panel current reading incorrect	Contact dealer for current calibration process

3.5 FUSE / MCB TABLE

WARNING: When replacing fuses always replace a fuse with the correct value. NEVER replace with a higher value / rating as this could damage the wiring harness. If a replacement fuse 'blows' do not keep replacing the fuse as you could damage the wiring harness. Please contact your dealer.

Fuse	Rating	Fuse Colour	Wire Colour	Description
1	15 Amps	Blue	Slate	Front Lights
2	15 Amps	Blue	Pink	Rear Lights
3	10 Amps	Red	Yellow / White	12v Sockets
4	10 Amps	Red	Black / Tracer	Fans
5	5 Amps	Tan	Yellow / Green	Heater / Hob / Other Ignitions (if fitted)
6	5 Amps	Tan	Slate / Red	Aux / Awning Light
7	10 Amps	Red	Green/Tracer/Purple	Water Pumps / Toilet
8	20 Amps	Yellow	*	Charger (internally connected)
Battery	20 Amps	Yellow	Brown / Blue	Fuse remotely located near battery

MCB	Rating	Wire Colour	Description
1	10 Amps	White	240v sockets
2	10 Amps	White (Yellow for heater)	Extra 240v Sockets / Heater
3	6 Amps	Black (Blue for water heater)	Fridge / Water Heater / 12v Charger (internally connected)

Electrical Systems

4. CONTROL PANEL OPERATION

4.1 LAYOUT AND BUTTONS

The following diagram shows the control panel layout.

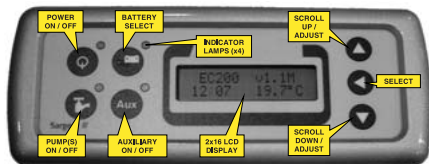

Item	Function	Options / Notes
Power ON / OFF	Use to turn the main power on and off	The adjacent LED is illuminated when the power is ON
Battery SELECT	Use to select the Leisure or Vehicle battery as the supply source	The adjacent LED is illuminated when the VEHICLE battery is selected; by default the Leisure battery is selected and is indicated by the battery select LED off.
Pump ON / OFF	Use to turn the water pump(s) power on and off (see section 4.3)	The adjacent LED is illuminated when the pump power is ON
Aux ON / OFF	Use to turn the entry light on and off	The adjacent LED is illuminated when the switch is ON
Scroll UP ▲	Use to scroll the display up (settings section of the menu) (see section 4.3)	Note: the menu screens operate in a continuous loop, therefore you can use either the UP or Down buttons to move to any screen
Scroll DOWN ▼	Use to scroll the display down (readings section of the menu) (see section 4.2)	
Select ◀	Use to select a menu item within the settings section (see section 4.2 & 4.3)	Use to move to the next setting, when entering alarm

Note: the display backlight operates for approximately 6 seconds after any key press

4.2 MENU FUNCTIONS - Readings section

Display	Description	Options / Notes
EC200 v1.1H 12:00 23.9°C	Main Control Panel display showing model number (EC200), software version number (v1.1), specification (H), current time (12:00) and internal temperature (23.9°C) in centigrade	The addition of an asterisk (*) in the top left of the display indicates that the alarm is set
LEISURE BATTERY 12.5V (GOOD)	Voltage reading and battery condition description for the on-board leisure battery	<10.9 = (Poor) 10.9 to 11.8 = (Fair) 11.9 to 14.4 = (Good)
VEHICLE BATTERY 13.3V (GOOD)	Voltage reading and battery condition description for the vehicle battery See section 4.4 for details of the Vehicle Battery save feature	<10.9 = (Poor) 10.9 to 11.8 = (Fair) 11.9 to 14.4 = (Good)
FRESH WATER 25% FULL	Water level in the fresh water tank (5 measurement levels)	0% < ¼ Full (Empty) 25% >= ¼ Full 50% >= ½ Full 75% >= ¾ Full 100% = Full
WASTE WATER 0% FULL	Water level in the waste water tank (2 measurement levels)	0% < ½ Full 50% >= ½ Full (optional) 100% = Full
EXTERNAL TEMP 26.5°C	External temperature (in degrees centigrade) as measured by the external temperature probe (only available in H specification systems)	
BATTERY CURRENT 5.4 AMPS	Current (in Amps) being drawn from or charged into the selected battery (only available in H specification systems)	Negative figure (-) = current being drawn from the selected battery Positive figure = current being used to charge the selected battery

Electrical Systems

4.3 MENU FUNCTIONS - Settings section

Display	Description	Options / Notes
PUMP SELECT <INTERNAL>	Not in use at this time	
CLOCK SET 12:00	Access to set the internal clock Press the select button (◀) to select the HOUR Use the up / down (▲ ▼) buttons to change Press the select button (◀) to select MINUTE Use the up / down (▲ ▼) buttons to change Press the select button (◀) to exit	Please note the clock uses a 24 hour cycle
ALARM SET 12:00	Access to set the alarm clock Press the select button (◀) to select the HOUR Use the up / down (▲ ▼) buttons to change Press the select button (◀) to select MINUTE Use the up / down (▲ ▼) buttons to change Press the select button (◀) to exit	Please note the alarm uses a 24 hour cycle
ALARM = OFF	Shows the alarm clock status (on / off) Press the select button (◀) to switch between OFF or ON	The addition of an asterisk (*) in the top left of the main display indicates that the alarm is set

4.4 WARNING MESSAGES

Display	Description	Options / Notes
VEHICLE BATTERY DANGEROUSLY LOW	This WARNING display indicates that the Vehicle battery voltage is low (10.9 volts or less). The panel will beep for one minute and then switch over to the Leisure battery to prevent draining the Vehicle battery	You can switch over to the Leisure battery immediately (and cancel the beep) by using the battery selector switch
SYSTEM DISABLED ENGINE STARTED	This WARNING display indicates that the system has been disabled because the vehicle engine is running	EMC (Electro Magnetic Compatibility) directive 89/336/EEC requires that electrical accessories within the vehicle are disconnected while the vehicle is in motion

Electrical Systems

5. TECHNICAL DATA & APPROVALS

5.1 OUTLINE SPECIFICATION

INPUT 230v	230 Volts / 0 to 16 Amps	+ / - 10%
OUTPUT 230v	RCD protected, 3 x MCB outputs of 10, 10 and 6A via 2 x 9 way connectors	
INPUT 12v	2 x 20A battery inputs via a 6 way connector	
OUTPUT 12v	20A total output via 4 16A switched channels protected by 7 fused outputs via a 15 way connector	
Integrated CHARGER	Input 110-240 Volts AC +/- 10%, Frequency 50Hz +/- 6%, Current 3.15A max DC Output 13.5 Volts nominal, Current 16 Amps max (200 Watts)	
Signal INPUT	4 x Fresh water level, 2 x Waste water level, 1 x Engine running via a 8 way connector	Fresh water negative sensed Waste water negative sensed
Data IN / OUT	Data communication and power to Control Panel via 20 way header connector IP31	
IP rating	Ambient 0 to 35°Centigrade	
Operating temperature	PSU case temperature with full load 40°C Max	Automatic shutdown and restart if overheated/ overloaded

5.2 APPROVALS

System: EN 1648-1, EN1648-2 compliant,
BS7671:2001 compliant

Electro Magnetic Compatibility (EMC) directive
89/336/EEC





Residual Current Device: RCD 40A 30mA trip to
BS EN 61008

Integrated Charger: BS EN 60335-1/2.29,
89/336/EEC, IEC61000-3.2/3:1995





Miniature Circuit Breakers: MCBs (10 & 6A)
type C6000A breaking capacity to EN 60898

CONTROL PANEL AC85 POWER CONTROL



Symbol	Function	Description
	12v power selection - leisure battery	This switch turns on (or off) the 12-volt power from the Leisure battery. Place the switch in the down position to draw power from the Leisure battery. Place the switch in the centre position to turn the power off.
	12v power selection - vehicle battery	This switch turns on (or off) the 12-volt power from the Vehicle battery. Place the switch in the up position to draw power from the Vehicle battery. Place the switch in the centre position to turn the power off. Please note that the vehicle battery should only be used for short periods of time / small loads otherwise the battery may become discharged and could prevent the vehicle from starting.
	Awning light	This switch operates the external awning light.
	Water pump	This switch turns on power to the internal water pump ready for use. It can be used to turn off the pump over night to avoid any noise from the pump. Note: A green indicator lamp will illuminate within the bottom left corner of the battery gauge when the pump motor is running.
	Battery level test	This switch is used to display the battery voltage level. Press and hold the switch to display the battery level on the gauge. The green region indicates a battery with a good charge, the yellow region indicates a battery with an adequate charge, and the red region indicates a battery that requires charging.

Electrical Systems

Symbol	Function	Description
	Water level test	This switch is used to display the fresh water level within the onboard water tank. Press and hold the switch to display the water level on the gauge. The gauge indicates the water level on an 'Empty - ¼ - ½ - ¾ - Full' scale, with empty being on the left.
	Waste level indicator ¾ full	This Red indicator illuminates when the water level in the wastewater tank is greater than or equal to 75% full (¾)
	Waste level indicator ½ full	This Amber indicator illuminates when the water level in the waste water tank is greater than or equal to 50% full (½)
		<p>When using the optional remote control unit, please ensure the control panel '12v Power' switch is in either the Leisure or Vehicle battery (ON) position and the 'Entry light' switch is in the OFF position for correct operation of the remote control (as the remote control operates in parallel with the control panel switches). The remote control button [I] controls the Entry Light and button [II] controls the 12v Power.</p> <p>If you do not wish to use the remote control, or the remote battery is flat / remote has been lost, you can of course return to manual operation by using the switches on the control panel. If the power has been turned off using the remote control and then the remote has been lost / battery become flat you will need to carry out the following to reset the motorhome: Place the power selector switch in the centre (OFF) position and turn the charger switch to the OFF position, wait 5 seconds and then turn the charger and power selector switch back on.</p> <p>The UH**** number on the back of the remote control is the remote code number. Please keep a record of this number in case you need to order a replacement or additional remote control.</p>

GENERATOR GUIDELINES

Your motorhome can be used with a generator provided these guidelines are met:

- Lack of regular servicing can be the cause of most generator problems, gensets under 2kW are mainly dependent on engine speed for output frequency and voltage. Poor or no servicing may cause the engine speed governor to run the genset too fast. Therefore, frequency and output voltage can rise above the specification of the machine data plate i.e. 230V at 50Hz. This may cause damage to electrical/electronic equipment (such as battery chargers).
- A generator should always run for a few minutes prior to connection with the motorhome electrics, to allow it to warm up and the output to settle to a steady level.
- The AC output of generators is often derived from an AC alternator, rectified to DC then inverted back to AC. In essence this means the output sinewave may not run sophisticated electronics efficiently. Some of the new wave of gensets are more sophisticated in their production of a sinewave output and are more suited to run electronic equipment.
- If in doubt consult your genset dealer or manufacturer for advice.

EQUIPMENT DETAILS

Truma Ultrastore Water Heater	52
Heating	55
Truma S 3002 Heater	55
Truma Ultraheat	57
Butterfly Outlets	59
Trumatic C6002 EH	60
Refrigerators	66
Models RM7361L, RM7360L, RM7405L	68
Model RM7605L	78
Stoves Hobs, Grills and Ovens	84
Dometic Extractor Fan	88
Sharp Microwave Oven	89
Thetford Cassette Porta Potti	92
Side Lockers	96
Bunk and Luton Bed Safety	96
Front Swivel Seat	96
Freestanding Table	96
Blinds	97
Windows	98
Rooflights	98
Shower	100
Omnistep Slide-out Step	100
Omnistep Double Step	102
Cab screens	103
Status 315 omnidirectional TV & FM radio antenna	104
Status 530 directional TV & FM radio antenna	104
Fiamma F45i side awning	105
DVD/AV output socket	106
Obserview reversing camera monitor	106
Satellite navigation with reversing camera provision	106
CD tuner	106

Equipment Details

The instructions covering fitted equipment to your motorhome were correct at the time of going to print. Owners handbooks are updated annually and we take great care to try and ensure their accuracy. However, the Swift Group Limited cannot accept responsibility for any changes that may be made in specification or operating instructions to the equipment described in this section after the time of going to press.

Every care is taken to ensure that the information provided in this handbook is correct and easy to understand.

Separate manufacturers' leaflets on many of the components are also included in the Owner's Pack provided with this caravan and we recommend that you compare the instructions in the handbook with the component manufacturers literature, to ensure the information provided is as accurate as possible.

If you are in any doubt as to how to operate the equipment in your caravan, please contact the component manufacturer's service department on the telephone number shown on their component leaflet. If you remain in any doubt, please contact the Swift Group Supercare customer care service department on 01482 875740.

Equipment Specification

For details on type of equipment fitted in your motorhome, please refer to the Sales Brochure or Dealer.

IMPORTANT

To maximise the use and life of all fitted equipment in your motorhome it is essential that any accompanying manufacturers' literature is read fully. All recommended maintenance and preparation procedures should be followed. The information provided in this handbook is only intended as a guide. If in any doubt consult your manufacturer appointed dealer, particularly BEFORE attempting to install EXTRA EQUIPMENT.

NOTICE: In the interest of safety, replacement parts for an appliance shall conform to the appliance manufacturer's specifications and should be fitted by them or their authorised agent.

THE TRUMA ULTRASTORE WATER HEATER

OPERATING INSTRUCTIONS

Attention: Before using for the first time, it is essential to flush the entire water supply through with clean warm water. Always mount the cowl cap when the water heater is not being operated! Drain the water heater if there is a risk of frost! **There shall be no claims under guarantee for damage caused by frost!**

Filling the Truma Ultrastore with water

e = Lever position "Closed"

f = Lever position "Drain"

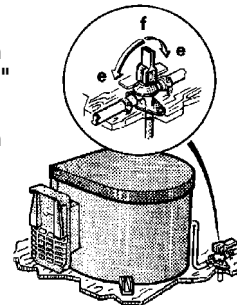

Fig. 1

1. Check that the safety/drain valve in the cold-water intake is closed. Lever should be in the horizontal position, position (e).

Equipment Details

- Open the hot tap in the bathroom or kitchen with pre-selecting mixing taps or single lever fittings set to hot.
- Switch on power for water pump (main switch or pump switch). Leave the tap open to let air escape while the water heater is filling. The heater is filled when water flows out of the tap.

Residues of frozen water can prevent filling if there is a frost. The water heater can be defrosted by switching on the heater for a short period (max 2 mins). Frozen pipes can be defrosted by heating the room.

Note: If just the cold water system is being used, without water heater, the heater tank is also filled up with water. In order to avoid damage through frost, the water contents must be drained by actuating the safety/drain valve, also when the heater has not been used. As an alternative, two shut-off valves, resistant to hot water, can be fitted in front of the cold and hot water connection.

Draining the water heater

- Disconnect power for water pump (main switch or pump switch).
- Open hot water taps in bathroom and kitchen.
- Open safety/drain valve: Lever in vertical position, position (f).

- The water heater is now drained directly to the outside via the safety/drain valve. Check that the water contents have been completely drained (10 litres).

Gas operating instructions

Attention: Never operate the water heater without water in it!

If the wall cowl is positioned close to an opening window (or hatch) - in particular directly under it - it must remain closed when the water heater is in use (see warning plate).

- Remove cowl cover.

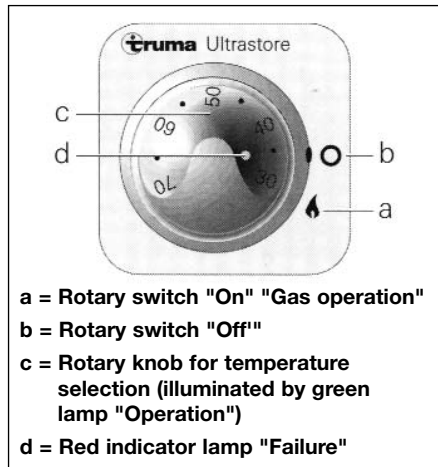

- Open gas cylinder and open quick-acting valve in the gas supply line.
- Select required water temperature at rotary knob (c) infinitely variable from approx. 30° to 70°C.
- Switch on water heater at the rotary switch (a) on the control panel, green indicator lamp "Operation" lights up.
- If there is air in the gas supply line, it may take up to a minute before the gas is available for combustion. If the appliance switches to "Failure" during this period, switch off the appliance - wait 5 minutes - and switch on again!

Equipment Details

Switching off (gas operation)

Switch off the water heater at the rotary switch (b).

Drain the water heater if there is a risk of frost!

If the water heater is not to be used for a longer period, mount cowl cover (non-observance of this point can lead to the function of the appliance being impaired through water, dirt or insects), close quick-acting valve in the gas supply line and close the gas cylinder.

There shall be no claim under guarantee if this point is not observed.

Always remove the cowl cover prior to operating the water heater!

Red indicator lamp "Failure"

The red indicator lamp (d) lights up if there is a failure.

The reason for such an indication is, for example, no gas available or air in the gas supply system, triggering of the excess temperature monitor etc. To unlock, switch off the appliance, wait 5 minutes, and switch on again.

In event of faults, always contact Truma Service on Tel: 01283 511092.

Electrical Operating Instructions

Switch the electric supply on at the fuse spur marked Water Heater, normally in the wardrobe.

When using the vehicle switches refer to operating instructions of the vehicle manufacturer or see switch labels.

Note: The water temperature cannot be selected, automatic temperature limitation at approx. 70°C. For a faster heating up period the appliance can be simultaneously operated with gas and electrical power.

Note: The water tank in the Truma-Ultrastore is made of high quality food-proof stainless steel VA.

Use wine vinegar for de-scaling the water supply. Allow the product to react and then thoroughly flush out the appliance with plenty of fresh water. To sterilise the water we recommend "Certisil- Argento". Other products, particularly those containing chlorine are unsuitable.

In order to avoid the proliferation of micro-organisms, heat the Ultrastore to 70°C at regular intervals.

Do not use the water as drinking water!

Important Operating Notes

1. If the cowl is positioned close to an opening hatch (window), keep this closed during operation. See warning plate. Always mount the cowl cover if the

heater is not being used. Non-observation of this point can lead to the function of the appliance being impaired through water, dirt or insects.

2. The guarantee will be invalidated if this point is not observed. Always remove the cowl cover prior to operating the water heater!
3. If there is a defect in the electronics, return the control Printed Circuit Board well padded. If you fail to pack it correctly the guarantee will be invalidated. Only use original Truma Ultrastore control PCBs as spare parts.
4. If just the cold water system is being used, without water heating, the header tank becomes more vulnerable to frost damage. Accordingly the contents should be drained by operating the safety/drain valve. This also applies when the motorhome is in storage.

General Safety Notes

In the event of leaks in the gas system or if there is a smell of gas:

- Extinguish all naked flames
- Do not smoke
- Switch off the appliance and gas cylinder
- Open the windows
- Do not operate any electrical switches
- Have the entire system checked by an expert

Equipment Details

1. Repair jobs are only to be carried out by an expert.
2. The following would invalidate the guarantee:
 - a. Any alteration to the appliance (including cowl)
 - b. The use of non-Truma spare parts/accessories
 - c. Non observance of the operating instructions.
3. The operating pressure for the gas supply is 30mbar (or 28mbar butane/37mbar propane) and must correspond to the operating pressure of the appliance (see name plate).
4. Do not operate the water heater when refuelling the vehicle and when in the garage.
5. During the initial operation of a brand new appliance (or after it has not been used for some time), a certain amount of fumes, and a slight smell, may be noticed for a short time. Remedial action is to immediately run the heater at maximum output and to ensure adequate room ventilation.
6. If the burner makes an unusual noise or if the flame lifts off, it is likely that the regulator is faulty and it is essential to have it checked.

Technical Data

Water contents:	10 litres
Water pressure:	up to max. 2.8 bar
Type of gas:	Liquid Gas (propane or butane)
Operating Pressure:	30mbar (or 28mbar butane, 37mbar propane)
Rated thermal output:	1500W
Gas consumption:	120g/h
Heating time to approx. 70°C:	
Gas operation:	approx. 35 mins
Electrical operation:	approx. 70 mins
Gas and electrical operation:	approx. 20 mins
Power consumption 12V	
Ignition:	0.17A
Heating Up:	0.08A
Standby:	0.04A
Power consumption 230V	
Heating Up:	(3.7A) 850W
Weight (empty):	6.7Kg

THE TRUMA S 3002 P & S 3002 AUTO SPACE HEATER

INSTRUCTIONS FOR HEATERS FITTED WITH AUTOMATIC IGNITOR OR PIEZO IGNITOR

Switching On

1. Open the valve on the gas cylinder. Open quick-acting valve in gas supply line.
2. Turn control knob to thermostat setting 1-10 and press it down as far as the stop. At the same time keep operating the piezo ignitor rapidly until the flame ignites.
3. Keep the control knob depressed for a further 10 seconds to allow the safety pilot to operate.
4. (Piezo only) Watch through the flame window for another 10 seconds to make sure that the flame does not go out through air in the supply pipe (caused by the valve being closed or changing the cylinder).

Attention: Always wait at least 2 minutes before attempting to re-ignite, otherwise there is a risk of blowbacks (misfiring). This also applies if a working heater goes out and has to be re-lit.

Equipment Details

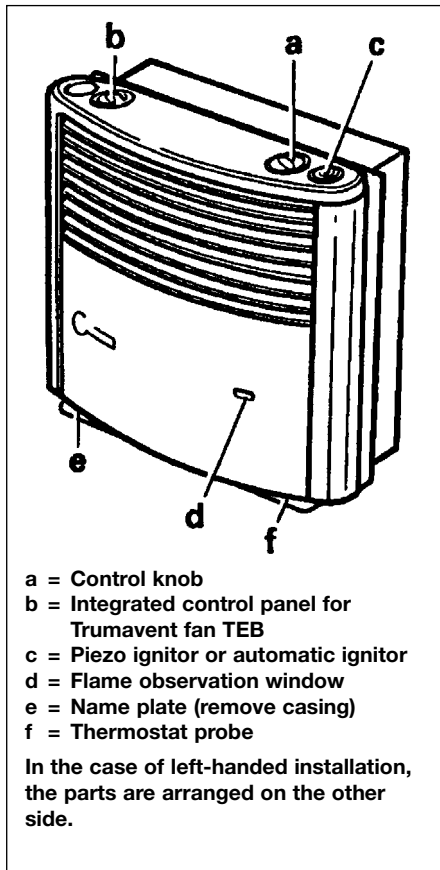

Automatic Ignitor

Prior to first ignition, make sure that the batteries have been inserted; observe correct fit battery cassette (see changing batteries, page 55).

Thermostat

Set the required room temperature at the control knob (numbers 1-10). For an average room temperature of approx. 22°C we recommend setting:

3-5 Without the Trumavent Fan
(switched on)

4-8 With the Trumavent Fan

Switching Off

Set control knob to "0". If turning off for a long period of time, close the quick-acting valve in the gas supply line. Close valve of gas cylinder.

Important Operating Notes

1. If the gas supply line is filled with air, it may take up to a minute before the gas becomes available for combustion. During this time depress the control knob and continuously operate the piezo ignitor until the flame ignites.
2. You will have to find out the exact thermostat setting yourself, depending on how much heat you need.
3. Repairs are only to be carried out by a competent service engineer.

Attention: A new O-ring must always be installed after dismantling the exhaust duct.

4. Any alteration to the appliance (including exhaust duct and cowl) or the use of spare parts and accessories, which are important to the function of the heater and which are not original Truma parts, as well as the non-observance of the installation and operating instructions, will lead to the cancelling of the guarantee and exclusion of liability claim.
5. During the initial operation of a brand new appliance, a certain amount of fumes and a slight smell may be noticed for a short while. Remedial action is to immediately run the heater at maximum output and to ensure adequate room ventilation.
6. In winter, before switching on the heater, remove all snow from the cowl.
7. Inspect the exhaust duct and all connections at regular intervals and always whenever there is a blowback (misfire). It is essential that the exhaust duct is installed so that it slopes upwards over its whole length and is securely fixed with several clamps. Never place any object on the exhaust duct, since this could result in damage. The exhaust duct connection to both the heater and the cowl must be firm and well sealed.

Equipment Details

Do not operate heaters with incorrectly fitted or damaged exhaust ducts.

8. Never allow the warm air outlet on the heater to be obstructed in any way. For instance never hang washing on or in front of the heater to dry. Misusing your heater in this way could cause serious damage from overheating. Do not place flammable objects near the heater. Please follow these guidelines in the interest of your own safety.
9. If the burner makes an unusual noise or if the flame lifts off while burning, it is likely that the regulator is faulty and it is essential to have it checked.
10. Cleaning (with switched off appliance): It is recommended that at least once a year, before the heating season starts, you remove any dust that has collected on the heat exchanger base plate.

Technical Data:

Type of gas:	Liquid gas (propane/butane)
Operating pressure:	30mbar (28mbar butane, 37mbar propane)
Rated thermal output:	3400W
Gas consumption:	30-280 g/h
Product Ident.	No: CE-0085AP0325

Automatic Ignitor

Power consumption: 50 MA (ignition)
0.01 MA
(monitoring)

Operating voltage: 3V

CHANGING OF BATTERIES

Changing the Batteries on the Automatic Ignitor

Only change the batteries with the heater switched off.

Always insert new batteries at the beginning of the heating season.

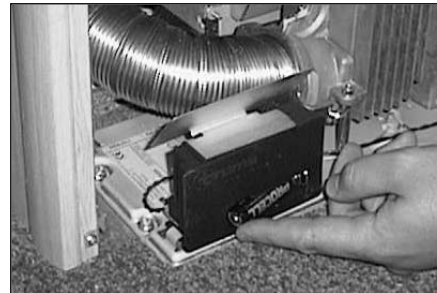

Remove front of heater retaining screw, located through centre of black grill. Unclip front of heater, slide up battery cover to reveal battery. Change the batteries. Observe plus/minus.

Only use temperature resistant (+70°C), leak-proof Mignon round cells (LR 6, AA, AM 3, Art. no. 30010-23600). Other batteries could lead to malfunctions!

TRUMA ULTRAHEAT ADDITIONAL ELECTRIC HEATING FOR TRUMATIC S 3002 (P), S 5002 AND S 55 T HEATERS

Function description

Truma-Ultraheat is an additional 230V electric heater for the LPG heater models Trumatic S 3002/S 5002.

Heater operation is basically possible with gas only, electricity only or simultaneously with electricity and gas.

When using simultaneously the electrical unit will switch itself off before overheating occurs as a result of the stronger gas burner.

When using electricity only we recommend to set the fan control on position 3 (manual or auto), remembering to set the output level to 2000W (ensure that the fuse protection for the power supply of the camp site is sufficient).

If more than 2kW are required (heating up/cold temperatures) you must refer back using gas operations as the 230V electrical operation is a secondary heater only.

Equipment Details

The electric heater can also be operated without the Trumavent fans.

WARNING: Due to the design, the heater front case will become hot during operation. The operator is obliged to ensure that due care is taken to protect third parties (small children in particular).

OPERATING INSTRUCTIONS

Before operating the heater for the first time it is essential to observe the operating instructions, enclosed with the heater.

Control panel with thermostat

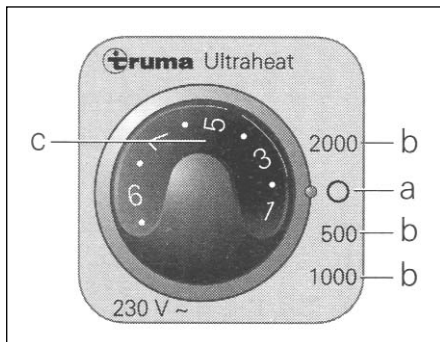

- a = Rotary switch "Off"
- b = Rotary switch "On"
power settings:
500 - 1000 - 2000 W
- c = Rotary control knob for room temperature (illuminated by green indicator lamp "operation")

Switching On

Attention: Before switching on, ensure that the fuse protection for the power supply of the campsite is sufficient for the selected power setting (b) (see Technical Data).

Important: The electric feed line for the caravan must be fully unwound from the cable drum.

1. Switch the electric supply on at the fuse spur marked Water Heater, normally in the wardrobe.
2. To switch on, turn the rotary switch to the desired output level (b).
3. Set rotary control knob (c) to the desired room temperature.

The thermostat setting on the operating element (1-9) must be determined individually depending on the heating requirement and the type of vehicle. For an average room temperature of about 23°C, we recommend a thermostat setting of about 6 -8.

The electric heater can also be operated without the Trumavent fans.

If the heater is operated simultaneously with electricity and gas, the electrical unit will switch itself off before overheating occurs as a result of the stronger gas burner.

Switching off

Switch the heating system off at the rotary switch (a).

IMPORTANT OPERATING NOTES

1. Repairs may only be carried out by an expert.
2. The heater's hot air outlet should under no circumstances be blocked. Never hang clothes or similar in front of or on top of the heater to dry. This could cause serious damage to the heater as a result of overheating. Do not place inflammable materials near the heater! Please observe these instructions for your own safety.
3. The performance of the room thermostat will be affected if temporarily covered or obstructed.
4. When operating a brand-new heater for the first time (or after it has been idle for a lengthy period) you may temporarily notice a slight smoke and smell. We advise running the heater at full power and thoroughly ventilating the room.

Equipment Details

- Any modifications to the appliance or the use of spare parts and accessories important for operation which are not original Truma parts, or non-observance of the instructions for installation and use will result in the guarantee becoming invalid and no liability will be assumed.

Furthermore the approval for operating the appliance will become invalid and in some countries also the approval for operating the vehicle.

TECHNICAL DATA

Power supply: 230 V ~, 50 Hz

Power consumption at power setting:

500 W: 2.2 A

1000 W: 4.5 A

2000 W: 8.5 A

Weight: approx 2kg

The mains element on the space heater is designed for supplementary heating. It is not recommended to run alongside the gas for prolonged periods of time.

BUTTERFLY OUTLETS

The butterfly plate may be opened or closed to control the quantity of air and may also be twisted around to control direction.

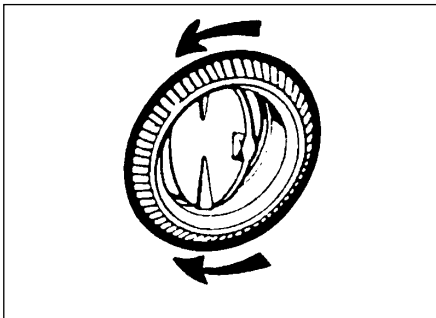

For uniform distribution, outlets nearest the heater should be closed more than those further away.

Blown air

The air ducting outlets are generally of the butterfly type and may be opened or closed by adjusting the butterfly valves. Twisting the disc in its housing directs the flow in the direction required.

One outlet on each leg of the air ducting layout must be kept open at all times.

Switching off

Push slide switch (a) to the "OFF" position.

IMPORTANT OPERATING NOTES

- Repairs may only be carried out by an expert.**

- Under no circumstances should the hot air outlet be blocked. Never hang clothes or similar in front of or on top of the heater to dry. This could cause serious damage to the heater as a result of overheating. Do not place inflammable materials near the heater! Please observe these instructions for your own safety.
- When operating a brand new heater for the first time (or after it has been idle for a lengthy period) you may temporarily notice a slight smoke and smell. We advise running the heater at full power and thoroughly ventilating the room.
- Any modifications to the appliance or the use of spare parts and accessories important for the operation, which are not original Truma parts, or non-observance of the instructions for installation and use will result in the guarantee becoming invalid and no liability will be assumed. Furthermore, the approval for operating the appliance will become invalid and in some countries also the approval for operating the vehicle.

TECHNICAL DATA

Power supply: 230 V ~, 50 Hz

Power consumption at power setting:

500 W: 2,2 A 1000W: 4,5 A 2000 W: 8,5 A

Weight: approx. 2 kg

Equipment Details

TRUMATIC C 6002 EH

Always observe the operating instructions and 'Important operating notes' prior to starting!

The vehicle owner is responsible for the correct operation of the appliance.

Before using for the first time, it is essential to flush the entire water supply through with clean warm water. If the heater is not being used, always drain the water contents if there is a risk of frost! **There shall be no guarantee claims for damage caused by frost!** Also drain the water prior to repair or maintenance work on the vehicle (in the workshop!) as the electrical safety/drain valve opens when the appliance is switched dead!

POWER SELECTOR SWITCH

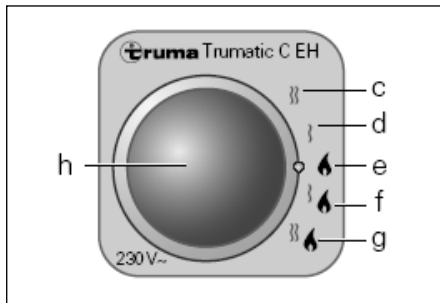

c = Electric operation 230 V, 1800 W

d = Electric operation 230 V, 900 W

e = Gas operation

f = Mixed operation*
(gas and electricity, 900 W)

g = Mixed operation*
(gas and electricity, 1800 W)

h = Yellow 'electric mode' indicator lamp.

* Winter mode only! In summer mode the unit automatically selects electric operation at the preselected electrical power of 900 W or 1800 W.

CONTROL PANEL

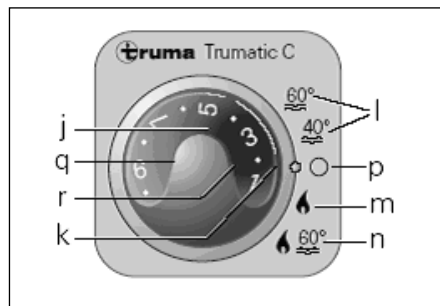

j = Rotary switch for room temperature (1 - 9)

k = Green 'Operation' monitor lamp

l = Summer mode
(water temperature 40°C or 60°C)

m = Winter mode
(heating without hot water requirement)

n = Winter mode
(heating with hot water requirement)

p = Rotary 'Off' switch

q = Yellow 'Boiler heating phase' monitor lamp

r = Red 'Fault' monitor lamp

Please observe the vehicle manufacturer's operating instructions when using vehicle-specific switches.

ROOM THERMOSTAT

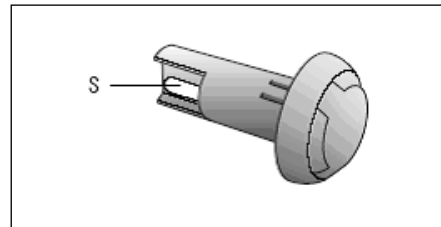

s = Room temperature sensor

To measure the room temperature, an external room temperature sensor (s) is located in the vehicle. The location of the sensor is determined individually by the vehicle manufacturer, depending on the

vehicle type; consult the operating instructions for your vehicle for further details

The thermostat setting on the operating element (1 – 9) must be determined individually depending on the heating requirement and the type of vehicle. For an average room temperature of about 23°C, we recommend a thermostat setting of about 6 – 8.

TAKING INTO OPERATION

Before start-up the following must be checked:

1. Is the cowl free? Remove all covers, and open deck cowl if equipment is being used on boats.
2. Are the gas cylinder and the quick-action stop valve in the gas pipe open?
3. Is the fuse protection for the 230 V power supply at the camping site adequate for the selected output (900 W or 1800 W)?
4. Has the power supply cable for the motorhome been fully unwound from the cable reel?
5. For electrical operation ensure the isolator switch on the PSU2007 marked HEATER is in the illuminated ON position.

Note: Heating is always possible in all operating modes (gas, electric and mixed operation) without restrictions, with or without water.

Summer mode (hot water only)

1. Select required type of operation at power selector switch (gas or electrical operation).

Note: Mixed operation (gas and electricity) is not possible in summer mode. With this setting the unit automatically selects electric operation at the preselected electrical power of 900 W or 1800 W.

2. Set rotary switch to summer mode (I) 40°C or 60°C at control unit. The green 'On' indicator lamp (k) and the yellow water heating indicator lamp (q) on the control unit illuminate when the equipment is switched on. During electrical operation the yellow indicator lamp (h) at the power selector switch also illuminates to indicate 230 V operation. When the selected water temperature has been reached (40°C or 60°C) the equipment switches off and the yellow control lamp (q) goes off.

Winter mode

Heating WITH hot water requirement

1. Select required type of operation at power selector switch (gas, electrical or mixed operation).
2. Move rotary knob (j) on the control panel to desired thermostat setting (1 – 9) for room temperature.

3. Move rotary switch on the control panel to 'n'. The green 'On' indicator lamp (k) and the yellow water heating indicator lamp (q) on the control panel illuminate when the equipment is switched on. During electrical operation the yellow indicator lamp (h) at the power selector switch also illuminates to indicate 230 V operation.

Depending on operating mode (gas, electrical or mixed operation) and power requirement (temperature difference between selected and current room temperature) the unit automatically selects the necessary power setting of up to 7800 W.

The unit gradually reduces the power until the selected room temperature is reached. If this temperature has been reached but the water still has to be heated, the circulation fan switches off and the water continues to be heated to a temperature of 60°C at the lowest power setting.

Note: The water can be heated to up to 80°C depending on the heating power that is required to achieve the room temperature. The yellow indicator lamp (q) indicates the hot water heating phase and goes off when the water temperature is reached (60°C).

Equipment Details

Heating WITHOUT hot water requirement

1. Select required type of operation at power selector switch (gas, electrical or mixed operation).
2. Move rotary knob (j) on the control panel to desired thermostat setting (1 – 9) for room temperature.
3. Move rotary switch on the control panel to 'm'. The green 'On' indicator lamp (k) on the control panel illuminates when the equipment is switched on. During electrical operation the yellow indicator lamp (h) at the power selector switch also illuminates to indicate 230 V operation.

In this operating position the yellow indicator lamp (q) only illuminates at water temperatures of less than 10°C!

Depending on operating mode (gas, electrical or mixed operation) and power requirement (temperature difference between selected and current room temperature) the unit automatically selects the necessary power setting of up to 7800 W.

When the selected room temperature has been reached, the heater switches off (independent of the water temperature).

Note: The water is automatically heated as well if the boiler has been filled. The water temperature can reach up to 80°C

depending on the power and the duration of the heating.

Switching off

Move rotary switch on the control panel to 'p' to switch off.

The fan can continue to run after switching off in order to utilise the residual heat.

Note: In order to prevent unintentional overloading of the power supply when resuming operation, it is advisable to set the unit to gas operation at the power selector switch after switching off.

Always drain water contents if there is a risk of frost!

If the appliance is not to be used for a prolonged period, close the quick-acting valve in the gas supply line and turn off the gas cylinder.

Gas operation fault

If a fault occurs during gas operation the red indicator lamp (r) on the control panel illuminates.

Possible causes can be found in the troubleshooting list.

Unlocking takes place by switching off and then switching on again. If a fault shut-off occurs during mixed operation (e.g. because of empty gas cylinder) the heater continues to run using electricity.

Electrical operation fault

If a fault occurs during electrical operation the yellow indicator lamp (h) on the power selector switch goes off.

Possible causes can be found in the troubleshooting list.

If the 230 V power supply is interrupted for short periods during operation the heating will resume as normal.

Filling the water heater

1. Manually close the drain valve at the control knob by lifting up (position a). At temperatures of around 8°C and less, switch on the heater or water heater first, to make sure the valve does not open again!
2. Switch on power for water pump (main switch or pump switch).
3. Open hot water taps in kitchen and bathroom, (set preselecting mixing taps or single-lever fittings to 'hot'). Leave taps open until the water heater has forced out air and filled up with water and water is flowing out of the taps.

Note: If just the cold water system is being operated, without using the water heater, the heater tank also fills up with water. In order to avoid damage by frost, the water contents must be drained by operating the safety/drain valve, also when the water

Equipment Details

heater has not been used. As an alternative, two shutoff valves, resistant to hot water, can be fitted in front of the cold and hot water connection.

WARNING: When connecting to a central water supply (rural or city mains), a pressure reduction valve must always be installed to prevent pressures above 2.8 bar from developing in the water heater.

Draining the water heater

1. Interrupt power for water pump (main switch or pump switch).
2. Open hot water taps in kitchen and bathroom.
3. Open safety/drain valve: lever in the vertical position (Fig A)

The water heater content is now emptied to the outside through the safety/drain valve. Place a bucket beneath the outlet to check whether the water content has completely drained away (12 litres!). **There shall be no guarantee claims for damage caused by frost!**

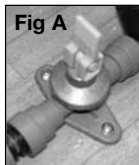

MAINTENANCE

The water container used is made of stainless steel, which is foodstuff-compatible.

Use wine vinegar for descaling the water heater, this being introduced into the appliance via the water supply. Allow the product to react and then thoroughly flush out the appliance with plenty of fresh water. To sterilise the water we recommend 'Certisil-Argento'. Other products, particularly those containing chlorine are unsuitable.

To avoid infestation by micro-organisms, the boiler must be heated to 70°C at regular intervals (only possible in winter operation). Do not use the water as drinking water!

Fuses 12 V

The 12 V fuses for the device are located on the electronic control unit (12). The fine-wire fuse must only be replaced by a fuse of the same design.

F1: 6.3 A, slow-acting

F2: 1.6 A, slow-acting

Fuses 230 V

The fuses and power connection cables must always be replaced by experts!

WARNING: Disconnect all poles of the unit from the mains before opening the housing containing the power electronics.

The 230 V fuse of the unit is in the power electronics (13) on the unit.

This fine fuse must always be replaced with a fuse of the same type.

10 A, slow-acting, cut-off delay 'H'.

Overheating protection 230 V

The 230 V heating facility has a mechanical overheating switch. If the 12 V power supply is interrupted during operation or during the afterrun period, for example, the temperatures within the unit could trigger the overheating protection.

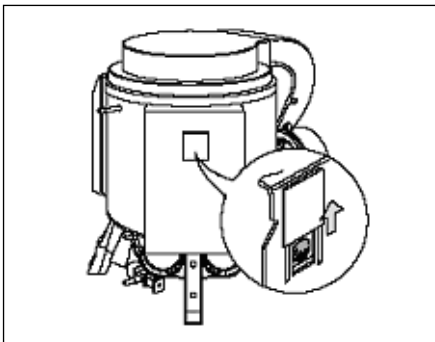

Equipment Details

To reset the overheating protection, let the heater cool down, slide cover on power electronics (13) upwards and push in the red button.

IMPORTANT OPERATING NOTES

Warning: Repairs may only be carried out by an expert!

- A new O-ring must always be installed after dismantling the exhaust duct!

- Always use original Truma spare parts for maintenance and repair work!

1. The integrity and tight fit of the exhaust gas double duct must be checked regularly, particularly at the end of long trips. Also check the mounting of the appliance and the cowl.
2. Following a blow-back (misfire) always have the exhaust gas system checked by an expert!
3. Always keep the cowl for the exhaust duct and combustion air intake free of contamination (slush, ice, leaves etc.).
4. The liquid gas burner operates fan-supported, which ensures trouble-free function even when on the move. National restrictions must be observed with regard to operation when on the move.

5. The installed temperature limiter shuts off the gas supply if the appliance becomes too hot. Therefore do not shut the warm air outlets and the opening for the returning circulating air.

TECHNICAL DATA

Type of gas:

Liquid gas (propane/butane)

Operating pressure: 30 mbar

Water contents: 12 Litres

Heating up time from approx. 15°C to approx. 60°C:

Summer-/gas operation: approx. 35 min.

Summer-/electrical operation (1800 W): approx. 45 min.

Winter mode: approx. 60 min. upward (depending on the heat output)

Water pressure: max. 2.8 bar

Rated thermal output:

Liquid gas: 2000 W, 4000 W, 6000 W

Electrical: 900 W, 1800 W

Gas consumption: 170 - 490 g/h

Air delivery volume

max. 287 m³/h (free-blowing without warm-air duct)

Current input at 12 V:

Heater + water heater: 0.2 – 5.9 A

Heating up of water heater: 0.4 A

Stand-by: 0.001 A

Current input of electrical safety/drain valve at 12 V: 0.035 A

Current input of 230 V:

900 W (3.9 A) or 1800 W (7.8 A)

Weight: approx. 18.7 kg (without water contents)

ABG test mark:

✓ S 301

Declaration of conformity:

The Trumatic C 6002 EH heater has been tested by the DVGW and complies with the EC gas device directive 90/396/EEC, the EMC directive 89/336/EEC, the low voltage directive 73/23/EEC and the associated EC directives, standards and technical specifications. The CE product identification number for EU states is: **CE-0085AS0122**.

EEC Type Approval: e1 022499

TROUBLE-SHOOTING

FAULT	CAUSE	RECTIFICATION
Gas operation		
No control lamp lights up when the system is switched on (winter and summer mode).	<ul style="list-style-type: none"> - No supply voltage. - Device fuse or vehicle fuse defective. 	<ul style="list-style-type: none"> - Check battery voltage (12 V). - Check all electrical plug connections. - Check device fuse (see Maintenance). - Check vehicle fuse.
The green indicator lamp comes on when the equipment is switched on, but the heater is not operating.	<ul style="list-style-type: none"> - The temperature setting on the control panel is lower than the room temperature. - Open window above cowl (window switch). 	<ul style="list-style-type: none"> - Select higher room temperature at the control panel. - Close window.
The red monitor lamp flashes after the heating system has been switched on.	<ul style="list-style-type: none"> - Battery voltage is too low < 10.5 V. 	<ul style="list-style-type: none"> - Charge battery.
About 30 seconds after the heating has been switched on, the red monitor lamp lights up and remains steady.	<ul style="list-style-type: none"> - Gas cylinder or quick-closure valve in the gas line is closed. - Air feed interrupted. 	<ul style="list-style-type: none"> - Check gas feed. - Check cowl for possible coverage. - If being used on boats, open the deck cowl.
Heating switches to fault mode after an extended period of operation.	<ul style="list-style-type: none"> - Hot-air outlets blocked. - Gas pressure regulator iced up. - Butane content in the gas cylinder too high. 	<ul style="list-style-type: none"> - Check individual outlet apertures. - Use de-icing system controller (Eis-Ex). - Use propane (at temperatures below 10°C in particular, butane is unsuitable for heating purposes).

Equipment Details

TROUBLE-SHOOTING

FAULT	CAUSE	RECTIFICATION
Electrical operation 230 V		
The green indicator lamp on the control panel illuminates when the unit is switched on, the yellow indicator lamp on the power selector switch does not illuminate and the heating does not become warm.	<ul style="list-style-type: none">- No supply voltage.- Device fuse defective.- Overheating switch has triggered.	<ul style="list-style-type: none">- Check 230 V supply voltage and fuses.- Check device fuse (see Maintenance).- Reset overheating switch (see Maintenance).

TROUBLE-SHOOTING

FAULT	CAUSE	RECTIFICATION
<p>Water supply</p>		
<p>When the heating system is switched off, the electrical safety/drain valve opens.</p> <p>- The valve remains open even after the heating has been switched on.</p>	<p>- Outside temperature below 4°C.</p> <p>- No 12 V power supply at the drain valve.</p>	<p>- Switch the heating on (at temperatures of about 4°C and below the drain valve will open automatically).</p> <p>- Check 12 V supply voltage and fuses.</p>
<p>The electrical safety/drain valve will no longer close.</p> <p>- The valve remains open even after the heating has been switched on.</p>	<p>- Outside temperature below 8°C.</p> <p>- No 12 V power supply at the drain valve.</p>	<p>- Switch the heating on (without heating operation, the drain valve will not close again until temperatures above 8°C have been reached).</p> <p>- Check 12 V supply voltage and fuses.</p>
<p>Water dripping from the electrical safety/drain valve.</p>	<p>- Water pressure too high.</p>	<p>- Check pump pressure (max. 2.8 bar). If connected to a central water supply (rural or urban connection), a pressure reducer must be used, which will prevent pressures higher than 2.8 bar entering the boiler.</p>

If these measures do not lead to the rectification of the fault, in principal we would ask you to contact Truma After Sales Service (see page 52 of the USER INSTRUCTIONS)

Equipment Details

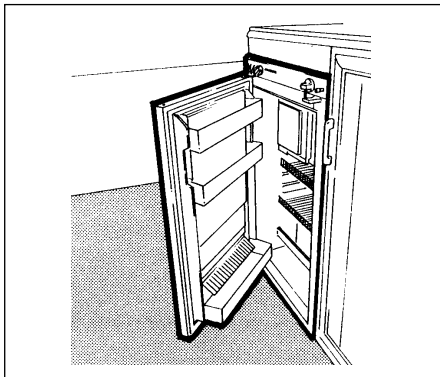

REFRIGERATORS

Before using your refrigerator for the first time, it is advisable to wash the interior and its accessories.

When using the refrigerator on gas ensure that the gas isolation tap is fully open by turning the knob to the vertical position. The tap is located inside the sink unit at floor height. When travelling the fridge can only be operated in the 12V mode.

Note: Before operating the refrigerator on 12V, it should be pre-cooled, together with its contents, by running it on gas or 230V for a few hours before changing over to 12V for your journey.

The current drain is approximately 7A to 14A (model specific) and power is only available when the ignition circuit is switched on. On site, only the mains electric or gas modes should be used.

The refrigerator can run on either 230V, 12V or LP gas. Changing between these modes of operation is carried out by means of the controls on the control panel.

Caution: Only use one source of energy at a time.

After initial installation, servicing or changing gas cylinders etc., the gas lines may contain some air which should be allowed to escape by briefly turning on the refrigerator or other appliances. This will ensure that the flame lights immediately.

The flame failure device will automatically shut off the gas to the burner if the flame is blown out. On electric ignition versions, the flame failure device will also shut off the gas if the burner does not re-light within about a minute of the flame being blown out.

DOMETIC RM7361L, RM7360L, RM7405L

You have made an excellent choice in selecting the Dometic Absorption Refrigerator. We are sure that you will be fully satisfied with your new appliance in all respects.

The appliance, which works silently, meets high quality standards and guarantees the efficient utilisation of resources and energy throughout its entire life cycle, during manufacture, in use and when being disposed of.

Before you start to use the appliance, please read the installation and operating instructions carefully.

The refrigerator is designed for installation in leisure vehicles such as caravans or motorcaravans. The appliance has been certified for this application in accordance with EU Gas Directive 90/396/EEC.

WARNING AND SAFETY NOTICES

Warning: Never use a naked flame to check the appliance for leaks.

- Protect children!
- When disposing of the refrigerator, remove all refrigerator doors and leave will prevent accidental locking in or suffocation.

Equipment Details

- If you smell gas:
 - close the locking tap of the gas supply and the valve on the cylinder.
 - open the windows and leave the room.
 - do not switch on anything electrical.
 - extinguish naked flames.
- Never open the cooling unit; it is under high pressure.
- **Work on the gas, flue system and electrical components must only be carried out by qualified service personnel.**
- It is imperative that the operating pressure should correspond to the data given on the model plate of the appliance.
- Compare the operating pressure data given on the model plate with the data on the pressure monitor of the liquid gas cylinder.
- Gas operation of the appliance is not permitted while travelling on ferries.
- Covers ensure electrical safety and must only be removed using a tool.
- The appliance must not be exposed to rain.
- The refrigerator is not suitable for the proper storage of medications.

COOLANT

Ammonia is used as a coolant.

This is a natural compound also used in household cleaning agents (1 litre of Salmiak cleaner contains up to 200g of ammonia - about twice as much as is used in the refrigerator). Sodium chromate is used for corrosion protection (1.8% of the solvent).

In the event of leakage (easily identifiable from the unpleasant odour):

- switch off the appliance.
- air the room thoroughly.
- inform the authorised Customer Service department.

WARRANTY AND CUSTOMER SERVICE

Warranty arrangements are in accordance with EC Directive 44/1999/CE and the normal conditions applicable for the country concerned. For warranty or other servicing, please contact our Dometic Service department. Any damage due to improper use is not covered by the warranty. The warranty does not cover any modifications to the appliance or the use of non-original Dometic parts.

The warranty does not apply if the installation and operating instructions are not adhered to and no liability shall be entertained. Parts can be ordered throughout Europe from our Dometic Service department.

Your Service Centre contact numbers are found in the "European Service Network" booklet.

When contacting Dometic Service, please state the model, product number and serial number together with the MLC Code, if applicable. You will find this information on the data plate inside the refrigerator.

DESCRIPTION OF MODEL

Refrigerator Mobile /
Mobile Absorption Refrigerator

"L" with interior light

RM 7401 L

Last digit 1 = manual energy selection

Last digit 5 = automatic and manual
energy selection

CLEANING

Before using the refrigerator, it is advisable to clean the appliance both inside and out.

- Use a soft cloth and lukewarm water with a mild detergent.
- Then rinse the appliance with clean water and dry thoroughly.
- Remove dust from the refrigerator unit at yearly intervals using a brush or soft cloth.

Equipment Details

Warning: To avoid deterioration of materials:

- Do not use soap or hard, abrasive or soda-based cleaning agents.
- Do not allow the door seal to come into contact with oil or grease.

Using the refrigerator

- The cooling unit is silent in operation.
- When the appliance is first put into operation, there may be a mild odour which will disappear after a few hours.
- Ensure the living area is well ventilated.
- The refrigerator will take several hours to reach its operating temperature in the cooling compartment
- The freezer compartment should be cold about one hour after switching on the refrigerator.

Controls

A. Manual energy selection MES (eg RM 7XX1 L)

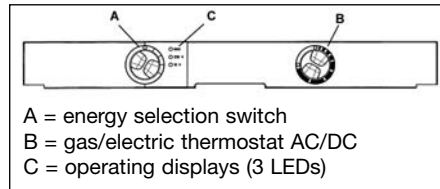

B. Automatic and manual energy selection AES (eg RM 7XX5 L)

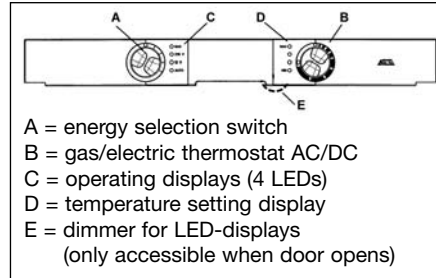

Note: The refrigerator is equipped to operate on mains power, DC or liquid gas (propane/ butane). The desired power option is selected by means of energy selector switch (A). Energy selector switch (A) has four settings: **AC** mains power, **DC** (12V), **Gas** (liquid gas), **OFF**.

Appliances with automatic energy selection have the additional setting "AUTO".

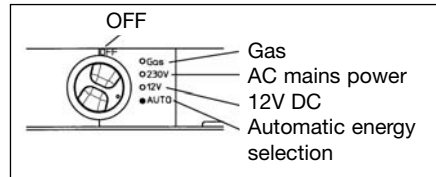

MANUAL ENERGY SELECTION

ELECTRICAL OPERATION

12V - operation (DC)

Warning: The refrigerator should only be used while the motor is running, otherwise the on-board-battery would be discharged within a few hours!

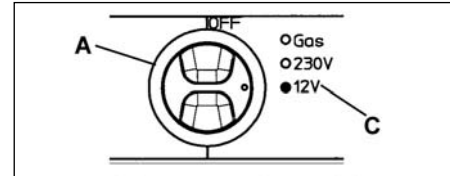

1. Set energy selector switch (A) to 12V .
2. Operating display "C", 12V lights "green". Appliance is in function.

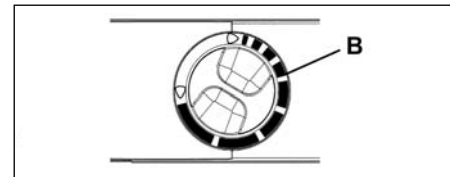

3. Use rotary switch (B) to regulate the temperature in the main refrigerator compartment.

Equipment Details

Note: If the operating display fails to light up (it lights up "red" at AES models) the device is not in operation. (For troubleshooting see page 74).

Mains power

This option should only be selected where the supply voltage of the connection for power supply corresponds to the value specified on the data plate. Any difference in values may result in damage to the appliance.

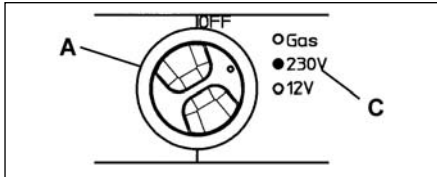

1. Set energy selector switch (A) to 230V .
2. Operating display "C", 230V lights "green".
Appliance is in function.

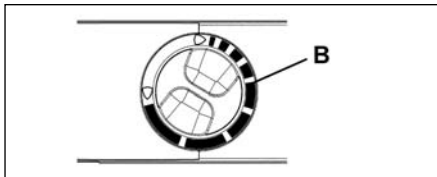

3. Use rotary switch (B) to regulate the temperature in the main refrigerator compartment.

Note: If the operating display fails to light up (it lights up "red" at AES models) the device is not in operation. (For troubleshooting see page 74)

GAS OPERATION

- The refrigerator should only be operated using liquid gas (propane, butane). Do not use town gas or natural gas.
- If the refrigerator is operated during travel using gas, the precautions stipulated by the legislation in the respective country must be taken (in conformity with the European standard EN 732).
- Operating the refrigerator with gas is not permitted during travel in France and Australia.
- As a basic rule, operation using gas is prohibited in petrol stations.

1. Open the valve of the gas cylinder
2. Open the shut-off valve to the gas supply.

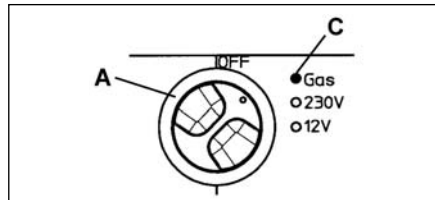

3. Set energy selector switch (A) to gas
4. Set rotary switch (B) to "MAX" position.

The ignition process is activated automatically, accompanied by a ticking sound approx. 30 sec. Upon successful ignition, the display LED (C) "Gas" lights yellow. The refrigerator is in function. Use rotary switch (B) to regulate the temperature in the main refrigerator compartment.

GAS FAULTS

In the event of a gas fault (e.g. gas cylinder empty), the operating display (C) flashes yellow.

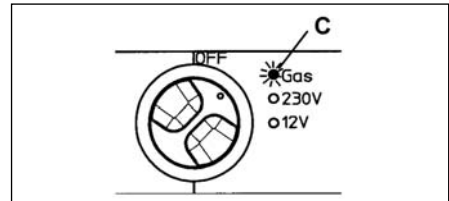

Remedies:

Set the energy selector switch (A) to position "OFF".

1. Is there any gas in the gas bottle?
2. Is the gas bottle valve open?
3. Is the on-board shut-off valve open?
4. Set the main switch (A) to "on"

The re-ignition starts again.

Equipment Details

If after about 30 seconds the operating display (C) starts flashing red again, the gas fault has not been cleared (e.g. air in the gas pipe).

5. Briefly switch the refrigerator off and then on again using main switch (A).

To remove air from the gas pipes, repeat this procedure 3-4 times.

If these actions do not help, please call an authorised Dometic Service Centre.

AUTOMATIC ENERGY SELECTION (ONLY WITH RM 7XX5 L)

"AUTO"-OPERATION

RM7XX5 L - models are equipped with an "AUTO"-MATIC function.

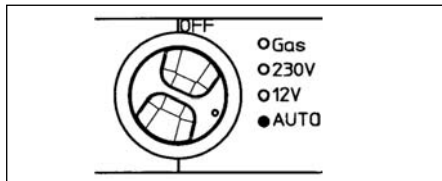

1. Set energy selection switch (A) to position "AUTO" .

The LED "AUTO" illuminates.

Note: Manual operation is possible at any time.

Explanations

Upon switching on, the electronics automatically select one of the three possible energy types: 230V - 12V – liquid gas. The control electronics automatically ensure that the refrigerator is supplied with the optimum source of energy in each respective case.

- Priority
- 1.) Solar (12V DC)
 - 2.) 230V AC
 - 3.) 12V DC
 - 4.) Liquid gas

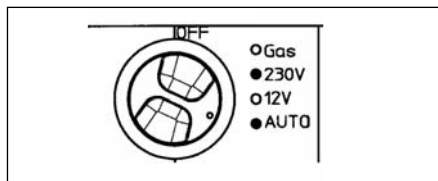

The selected energy is displayed by the corresponding LED (i.e. 230V).

230 V - operation

If sufficient supply voltage is available (more than 200V), this power source is selected as the first option (no solar-system installed).

12 V - operation

12V operation should only be selected while the vehicle motor is running or there is sufficient voltage available from the sola

system. This can be detected from the D+ connection of the alternator to the electronics, or from the respective signal on the solar charge regulator.

GAS OPERATION

Gas operation is selected in the following circumstances:

- No supply voltage available.
- The vehicle engine is not running.
- Supply voltage less than 200V

Refuelling Stop

In order to prevent unintended switching to gas operation during refuelling, the electronic system starts gas operation of the refrigerator, after the motor has been turned off for 15 mins. During this time the appliance is in stand-by operation mode and only the "AUTO" LED lights up

The use of naked flames is prohibited in petrol station environments. If the refuelling stop lasts longer than 15 mins the refrigerator should be switched off at the main switch (A), or switched over to another energy type.

Equipment Details

Gas faults at "AUTO"- mode

If gas faults occur the operating LED "C" flashes yellow.

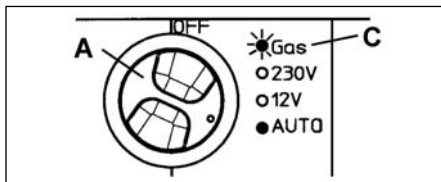

Remedies:

Set the energy selector switch (A) to position "OFF".

1. Is there any gas in the gas bottle?
2. Is the gas bottle valve open?
3. Is the on-board shut-off valve open?
4. Set the main switch (A) to "on".
The ignition starts again.

If after about 30 seconds the operating display (C) starts flashing red again, the gas fault has not been cleared (e.g. air in the gas pipe).

5. Briefly switch the refrigerator off and then on again using main switch (A).

To remove air from the gas pipes, repeat this procedure 3-4 times.

If these actions do not help, please call an authorised Dometic Service Centre.

Additional functions (RM 7XX5 L - models only)

- Temperature setting display (D) with 4 LED to indicate the selected temperature (MIN - MAX)
- LED - dimmer (E) for adjusting the brightness of the display-LED (only accessible when door opens)

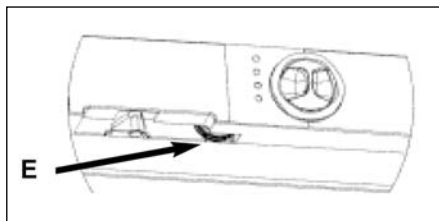
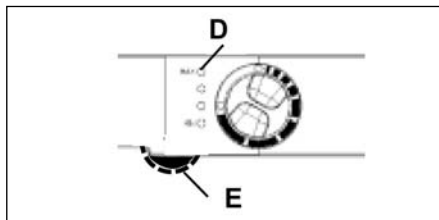

Underneath the fascia is a knurled knob for adjusting the brightness (see item E above).

Temperature setting cooling compartment

As shown, you are able to regulate the temperature of the cooling compartment, if necessary, by turning rotary knob (B).

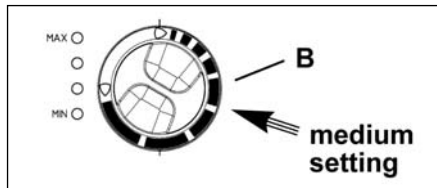

The cooling unit's performance is influenced by ambient temperatures.

Tip: Please select the medium setting for ambient temperatures between +15°C and +25°C. The unit operates within its optimum performance range.

STORING FOOD

- Switch the refrigerator on approximately 12 hours before filling it.
- Always store food in sealed containers, aluminium foil or similar.
- Never put hot food into the refrigerator, always let it cool down first.
- Products that could emit volatile, flammable gases must not be stored in the refrigerator.
- Store quickly perishable foods directly next to the cooling fins.

The freezer compartment is suitable for making ice cubes and for short-term storage of frozen food. It is not suitable as a means of freezing foods.

Equipment Details

MAKING ICE CUBES

Ice cubes are best frozen overnight. At night, the refrigerator has less work to do and the unit has more reserves.

1. Fill the ice cube tray with drinking water.
Only use drinking water!
2. Place the ice cube tray in the freezer compartment.



DEFROSTING

As time goes by, frost builds up on the fins. When the layer of frost is about 3mm thick, the refrigerator should be defrosted.

1. Switch off the refrigerator, as described on page ?? - "Switching off".
2. Remove the ice cube tray and food.
3. Leave the refrigerator door open.
4. After defrosting (freezer compartment and fins free of frost), wipe the cabinet dry with a cloth.

5. Use a cloth to mop up the water from the freezer compartment.
6. Switch the refrigerator back on again.

Warning: The layer of ice must never be removed forcibly, nor may defrosting be accelerated using a heat source.

Note: Water thawing in the main compartment of the refrigerator runs into an appropriate container at the back of the refrigerator. From there, the water evaporates.

POSITIONING THE STORAGE RACK

Dismantling:

1. Loosen the front and back securing brackets.
2. Move the storage rack to the left and remove it.



To fit the storage rack, the reverse order applies.

DOOR LOCKING

Open

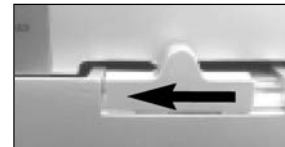

Close

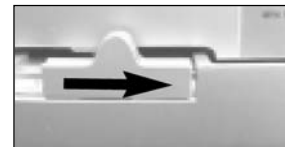

Park-position/
vent-position

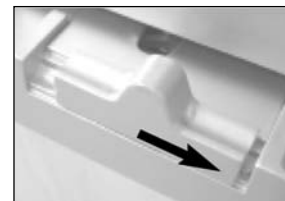

SWITCHING OFF

1. Set energy selector switch (A) to position "0" (OFF). The appliance is now fully switched off.
2. Secure the door open by means of the door stop. The door will be slightly ajar. This is to prevent mould from forming inside the appliance.

Equipment Details

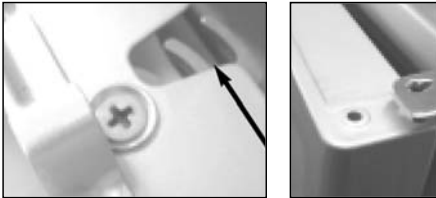
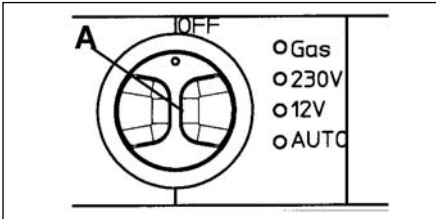

Switching off gas operation

If the refrigerator is to be taken out of service for an extended period of time, the on-board shut-off valve and the cylinder valve must be closed.

WINTER OPERATION

1. Check that the ventilation grills and the extractor have not been blocked by snow, leaves or similar.
2. When the ambient temperature falls below **+8°C**, the optional winter covers should be fitted. This protects the unit from excessively cold air.



Lower ventilation grille (L200)

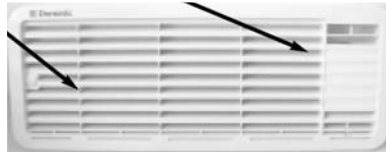

Upper ventilation grille with flue vent (L100)

3. Affix the cover and fasten it.



Tip: It is also recommended that the winter covers should be used when the vehicle is taken out of service for an extended period of time.

Equipment Details

INTERIOR LIGHT

Changing the light bulbs

1. Remove cover.
2. Detach defective light bulb.
3. Fit new light bulb
4. Clip the cover back in place.

Note: For 12V DC : 1 light bulb 12V, 2W

Please contact Dometic Service Centres for replacement light bulbs.

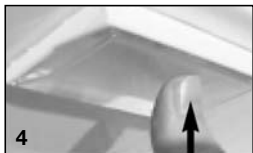
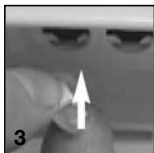
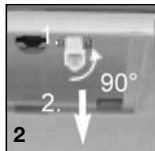
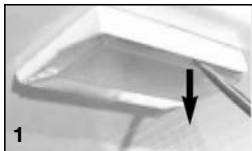

TROUBLESHOOTING

Before calling the authorised Service Department, please check whether:

1. The instructions in the section "Using the refrigerator" have been followed.
2. The refrigerator is not tilted excessively.
3. It is possible to operate the refrigerator with an available power source

Failure : The refrigerator does not work in gas operation mode

Possible cause	Action you can take
Gas bottle empty.	Change gas bottle.
Is the supply cut-out device open?	Open the cut-out device.
Air in the gas pipe?	Switch device off and on again 3-4 times to remove air from the gas pipe.

Note: The Seven Series refrigerator requires a constant 12 volt supply for the fridge to operate on gas. Disconnecting the leisure battery will switch off the gas operation of the fridge.

Failure : The refrigerator does not work on 12V

Possible cause	Action you can take
On-board fuse defective.	Fit new fuse.
On-board battery discharged.	Check battery, charge it.
Engine not running.	Start engine.

Equipment Details

Failure : The refrigerator does not work on 230V

Possible cause	Action you can take
On-board fuse defective.	Fit new fuse.
No connection to supply voltage.	Establish power connection.
AES: gas operation despite connection to the supply voltage?	Appliance switches to gas operation due to insufficient supply voltage (automatically switches back to 230 V operation)

Failure : The refrigerator does not cool sufficiently

Possible cause	Action you can take
Inadequate ventilation to the unit.	Check that the ventilation grilles are not covered.
The thermostat setting is too low.	Turn the thermostat to a higher setting.
There is too much ice on the condenser.	Check that the refrigerator door seals when shut.
Too much warm food put inside.	Let food cool down first.
Appliance running for a short time.	Wait several hours, check again.

MAINTENANCE

- Works on gas components and electrical installation may only be carried out by authorised personnel. We recommend to contact your Dometic Service Centre.
- EN 1949 stipulates that the appliance's gas equipment and its associated fume system must be inspected after installation and a certificate issued.

Afterwards a qualified technician must inspect according to EN 1949 every two years and a certificate issued.

It is the user's responsibility to arrange for inspections after purchase.

- It is recommended that the gas burner be inspected and cleaned as necessary at least once a year. We recommend maintenance following an extended shutdown of the vehicle.

PRODUCT LIABILITY

Product liability of Dometic GmbH does not include damages which may arise from faulty operation, improper alterations or intervention in the equipment, adverse effects from the environment such as changes in temperature and air humidity, which may impact the equipment itself or the direct vicinity of the equipment or persons in the area.

Equipment Details

ENVIRONMENTAL HINTS

Refrigerators manufactured by Dometic GmbH are CFC-free.

Ammonia (a natural compound of hydrogen and nitrogen) is used in the cooling unit as a coolant. The non-ozone-hazardous cyclopentan is used as a propellant in the manufacture of the PU foam insulation.

DISPOSAL

In order to ensure that the recyclable packaging materials are re-used, these should be sent to the usual local collection system.

The appliance should be transferred to a suitable waste disposal company that will ensure re-use of the recyclable components and proper disposal of the rest.

For eco-friendly draining of the coolant from all absorber refrigeration units, a suitable disposal plant should be used.

ENERGY-SAVING TIPS

- At an average ambient temperature of approx. 25°C, it is sufficient to operate the refrigerator at the middle thermostat setting (for both gas and mains voltage).
- Where possible, always store goods that have previously been cooled.
- Do not position the refrigerator in direct sunlight.
- Constant circulation of air must be supplied to the refrigerator unit.
- Defrost regularly.
- Open the door only for a short time when removing goods from the refrigerator.
- Run the refrigerator for about 12 hours before filling it.

DOMETIC RM 7605 L

The refrigerator can be run on 230V, 12V or LP gas. Changing between these modes of operation is carried out by means of the control buttons positioned as shown in fig. A.

A) Manual energy selection

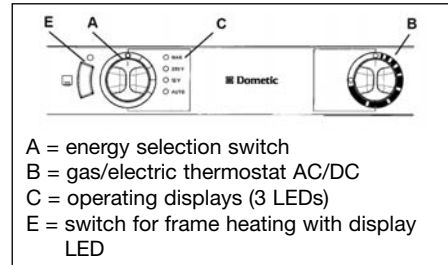

B) Automatic and manual energy selection

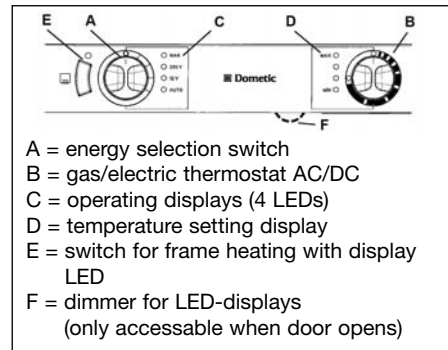

Equipment Details

Note: The refrigerator is equipped to operate on mains power, DC or liquid gas (propane/butane). The desired power option is selected by means of energy selector switch (A).

Energy selector switch (A) has four settings: **AC** mains power, **DC** (12V), **Gas** (liquid gas), **OFF**.

Appliances with automatic energy selection have the additional setting "AUTO"

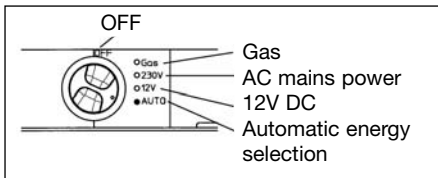

Electrical operation 12V - operation (DC)

The refrigerator should only be used while the motor is running, otherwise the on-board-battery would be discharged within a few hours!

1. Set energy selector switch (A) to 12V .

Operating display "C", 12V lights "green".

Appliance is in function.

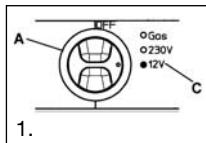

2. Use rotary switch (B) to regulate the temperature in the main refrigerator compartment.

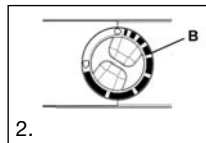

If the operating display fails to light up (it lights up "red" at **AES** models) the device is not in operation. (For troubleshooting see 5.13 of the user manual)

Mains power

This option should only be selected where the supply voltage of the connection for power supply corresponds to the value specified on the data plate. Any difference in values may result in damage the appliance.

1. Set energy selector switch (A) to 230V
Operating display "C", 230V lights "green".

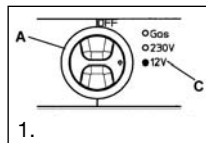

Appliance is in function.

2. Use rotary switch the temperature in the main refrigerator compartment.

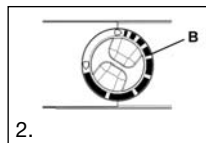

If the operating display fails to light up (it lights up "red" at **AES** models) the device is not in operation. (For troubleshooting see 5.13 of the user instructions)

Gas operation

- The refrigerator should only be operated using liquid gas (propane, butane). Do not use town gas or natural gas.
- If the refrigerator is operated during travel using gas, the precautions stipulated by the legislation in the respective country must be taken (in conformity with the European standard EN 732).

Operating the refrigerator with gas is not permitted during travel in France and Australia.

As a basic rule, operation using gas is prohibited in petrol stations.

1. Open the valve of the gas cylinder
2. Open the shut-off valve to the gas supply.

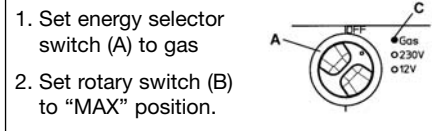

The ignition process is activated automatically, accompanied by a ticking sound approx. 30 sec. Upon successful ignition, the display LED (C) "Gas" lights yellow. The refrigerator is in function. Use rotary switch (B) to regulate the temperature in the main refrigerator compartment.

Equipment Details

Automatic Energy Selection

“AUTO”-operation

RM7XX5 L - models are equipped with an “AUTO”-MATIC function.

1. Set energy selection switch (A) to position “AUTO” .

The LED “AUTO” illuminates.

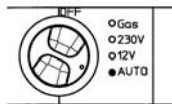

Manual operation is possible at any time.

Explanations:

Upon switching on, the electronics automatically select one of the three possible energy types: 230V - 12V - liquid gas. The control electronics automatically ensure that the refrigerator is supplied with the optimum source of energy in each respective case.

- Priority
- 1.) Solar (12V DC)
 - 2.) 230V AC
 - 3.) 12V DC
 - 4.) Liquid gas

The selected energy is displayed by the corresponding LED (i.e. 230V).

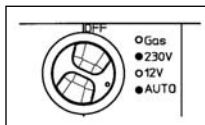

230 V - operation

If sufficient supply voltage is available (more than 200V), this power source is selected as the first option (no solar-system installed).

12 V - operation

12V operation should only be selected while the vehicle motor is running or there is sufficient voltage available from the solar system. This can be detected from the D+ connection of the alternator to the electronics, or from the respective signal on the solar charge regulator.

Gas operation

Gas operation is selected in the following circumstances:

- No supply voltage available.
- The vehicle engine is not running.
- Supply voltage less than 200V

REFUELLING STOP

In order to prevent unintended switching to gas operation during refueling, the electronic system starts gas operation of the refrigerator, after the motor has been turned off for 15mins. During this time the appliance is in stand-by operation and only the “AUTO” LED lights up.

The use of naked flames is prohibited in petrol station environments. If the refuelling stop lasts longer than 15mins, the refrigerator should be

switched off at the main switch (A), or switched over to another energy type.

Gas faults (RM 76x1 and RM 76x5)

If gas faults occur the operating LED “C” flashes yellow.

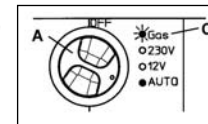

Remedies:

Set the energy selector switch (A) to position “OFF”.

1. Is there any gas in the gas bottle?
2. Is the gas bottle valve open?
3. Is the on-board shut-off valve open?
4. Set the main switch (A) to “on” The ignition starts again.

If after about 30 seconds the operating display (C) starts flashing red again, the gas fault has not been cleared (e.g. air in the gas pipe).

- Briefly switch the refrigerator off and then on again using main switch (A). To remove air from the gas pipes, repeat this procedure 3-4 times.

If these actions do not help, please call an authorised Dometic Service Centre.

Frame heating

Both models are equipped with a frame heating (12VDC/3,5W) around the freezer compartment. During summer months with high temperatures and humidity the metal frame may have water droplets forming.

To evaporate these droplets switch on the frame heating with switch (A). The LED (B) indicates that the heating is on.

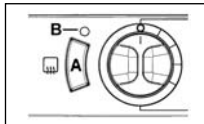

The frame heating will draw 12V DC power continuously. Observe LED (B) when the engine is shut off while parking the vehicle. Shut off the frame heating.

Additional functions

- Temperature setting display (D) with 4 LED to indicate the selected temperature (MIN - MAX)
- LED - dimmer (E) for adjusting the brightness of the display-LED (only accessible when door opens)

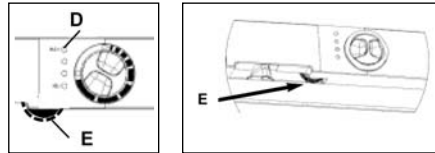

Underneath the fascia is a knurled knob for adjusting the brightness (see item E above)

Temperature setting cooling compartment

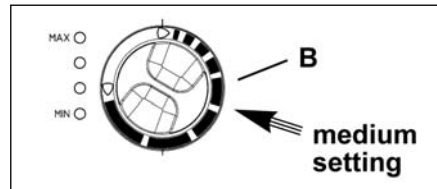

As shown, you are able to regulate the temperature of the cooling compartment, if necessary, by turning rotary knob (B).

Tip: The cooling unit's performance is influenced by ambient temperatures. Please select the **medium setting** for ambient temperatures between +15°C and +25°C. The unit operates within its optimum performance range.

DOMETIC refrigerators work according to the absorption principle. Due to physical reasons, an absorption system responds slowly to changes made on the thermostat controller, or a loss in cooling through opening the door, or storing food. The devices are subject to the Climatic Class SN acc. To EN/ISO 7371 in the temperature range of +10°C to 32°C ambient temperature.

Equipment Details

TROUBLESHOOTING

Before calling the authorised Service Department, please check whether:

1. The instructions in the section "Using the refrigerator" have been followed.
2. The refrigerator is not tilted excessively.
3. It is possible to operate the refrigerator with an available power source.

Failure : The refrigerator does not work in gas operation mode.

Possible cause	Action you can take
Gas bottle empty.	Change gas bottle.
Is the supply cut-out device open?	Open the cut-out device.
Air in the gas pipe?	Switch device off and on again 3-4 times to remove air from the gas pipe.

Failure : The refrigerator does not work on 12V.

Possible cause	Action you can take
On-board fuse defective.	Fit new fuse.
On-board battery discharged.	Check battery, charge it
Engine not running.	Start engine.

Failure : The refrigerator does not work on 230V.

Possible cause	Action you can take
On-board fuse defective.	Fit new fuse.
No connection to supply voltage.	Establish power connection.
AES: gas operation despite connection to the supply voltage?	Appliance switches to gas operation due to insufficient supply voltage (automatically switches back to 230 V operation)

Equipment Details

Failure : The refrigerator does not cool sufficiently.

Possible cause	Action you can take
Inadequate ventilation to the unit.	Check that the ventilation grilles are not covered.
The thermostat setting is too low.	Turn the thermostat to a higher setting.
There is too much ice on the condenser.	Check that the refrigerator door seals when shut.
Too much warm food put inside.	Let food cool down first.
Appliance running for a short time	Wait several hours, check again.

DOMETIC RM 7630

APPLIANCES WITH CURVED DOOR AND GALVANOMETER

Manual ignition with "Piezo" igniter

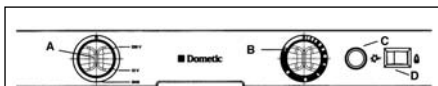

- A = energy selector switch
- B = gas/electric thermostat
- C = manual ignition button
- D = flame indicator device (galvanometer)

The refrigerator is equipped to operate mains power, DC or liquid gas. The desired power option is selected by means of energy selector switch (A) which has four settings:

- Off (O)
- AC mains power (230V)
- DC (12V)
- Liquid gas (Gas).

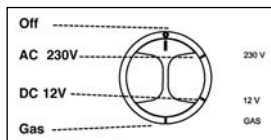

Electrical operation

Please refer to the manual

Gas operation

1. Open the valve of the gas cylinder
2. Open the shut-off valve to the gas supply.
3. Set energy selector switch (A) to Gas.

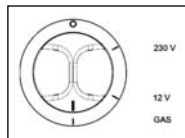

4. Press and hold rotary switch (B).

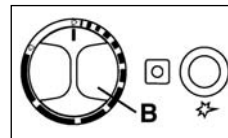

5. Activate Piezo ignition (C) several times at intervals of 1 sec.

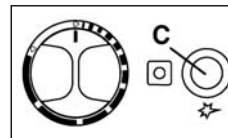

6. Once the flame has been ignited and is burning, the needle of the galvanometer passes over into the green section.

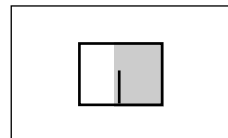

7. Release igniter button (C). Keep rotary switch (B) depressed for another 10-15 seconds, then release.
8. Check the flame indicator to see whether a flame is burning.
9. Repeat the entire process if the flame has gone out.
10. Use rotary switch (B) to regulate the temperature in the main refrigerator compartment.

Equipment Details

STOVES HOBBS, GRILLS AND OVENS

PLEASE READ THE MANUFACTURER'S INSTRUCTIONS BEFORE OPERATING THE APPLIANCE

WARNING: When you are cooking it is essential to provide additional ventilation such as opening windows near the grill, cooker and oven.

WARNING: When using cooking or heating appliances, surfaces and handles may become hot. Care should be taken and if necessary hand protection used.

WARNING: Extra care should be taken when accessing the locker above the hob especially whilst the hob is in use. Always be aware when opening the locker door objects could fall out onto cooking pans causing injury.

BURNER IGNITION

The hotplate lid must be open for the hotplate, grill or oven burners to ignite.

The ignition should not be operated for more than 15 seconds. If, after 15 seconds the burner has not lit, stop operating the ignition, open the compartment door and wait at least 1 minute before attempting to ignite the burner.

In the event of the burner flames being accidentally extinguished, turn off the burner control and do not attempt to re-light the burner for at least 1 minute.

SPARE PARTS

When ordering spare parts, please give the following information so the appliance can be correctly identified:

1. The name of the appliance from the fascia, and its colour.
2. The model number and the serial number of the appliance (from the data badge).

BE SAFE - NOT SORRY

Warning: Good ventilation is essential to the continuing safe operation of all gas appliances. Do not allow any ventilation openings to become accidentally or deliberately blocked.

Keep all flammable materials (such as curtains, furnishings, towels and clothing) away from the appliance.

Parts of the appliance may be hot during or immediately after use. Allow sufficient time for the appliance to cool after switching off.

When opening the appliance door, take care to avoid skin contact with any steam which may escape from the cooking.

Do not use aluminium foil to cover the grill pan, or put items wrapped in foil under the grill as this can create a fire hazard.

Do not use the oven with the door inner glass panel removed (glass oven doors only).

If the cooker has a storage compartment below the oven, this should only be used to store oven furniture. Do not store any flammable materials in this compartment.

When cooking with fat or oil, never leave unattended.

Turn pan handles inwards so they are out of reach of children and cannot be caught accidentally.

Glass lids may shatter when heated, turn off all burners before shutting the lid.

Models without ignition button: For safety reasons, we recommend the use of a hand held spark ignitor or gas lighter to ignite the burner, rather than a match or taper, which could allow burning debris to fall behind the appliance.

When you have finished cooking, check that all controls are in the off position.

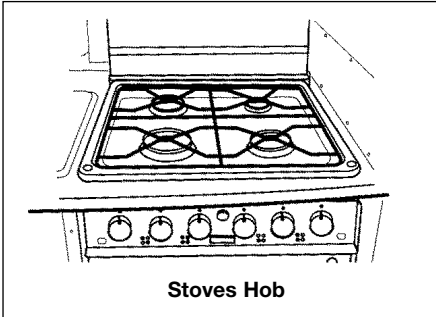

Stoves Hob

THE HOB

Caution:

- Do not use foil on the hob, as it creates a fire hazard
- Glass lids may shatter when heated, turn off all burners before shutting the lid
- Note: When positioning the pan support, ensure that the fingers are central to the burners (Fig 1).

Always use the most appropriate size of burner for the pan you wish to use. Use pans with a flat base of minimum 100mm/4 ins diameter, and maximum 200mm/8 ins diameter, which are stable in use. Avoid old or misshapen pans as these may cause instability.

Important: Any spillage of liquid should be cleaned away immediately to reduce the risk of fluid entering the appliance.

Ignition - Push in the control knob and turn anticlockwise to the large flame symbol. Keep the knob depressed, and press the ignition button (if fitted), or use a hand held spark ignitor or gas lighter. The knob must be held in for 15-20 seconds before releasing.

ELECTRIC HOTPLATES

Before using for the first time, prime the hotplate - switch it on without a pan to harden and burn off the coating. Use a medium-high setting for 3 - 5 minutes. A non-toxic smoke may occur.

To switch on, turn the hotplate control knob to the required setting.

The high speed hotplate ring (if fitted) is identified by its central red spot - this ring has a faster response time.

THE GRILL

- Note: The door must be open when the grill is used.
- Caution: When the grill is being used, accessible parts may be hot; young children should be kept away.
- Never cover the grill pan or grid with cooking foil, or allow fat to build up in the grill pan as this creates a fire hazard.
- Keep all flammable material away from the appliance.

To light the grill

Push in the control knob and turn anticlockwise to the large flame symbol. Keep the knob depressed, and press the ignition button (if fitted), or use a hand held spark ignitor or gas lighter. The knob must be held in for 15-20 seconds before releasing.

Detachable grill handle (if supplied)

Place the handle (shield uppermost) over the edge of the grill pan at the recess and slide along to position centrally between the two locator bumps. To remove the handle, place the grill pan down, and lift the handle slightly as you slide it along the recess.

Using the grill

Push in the grill pan until it locates centrally under the grill burner

There are three different grilling positions as the trivet can be inverted to give a high or low position or it may be removed.

1. The high trivet position is suitable for toasting bread.
2. The low trivet position is suitable for grilling all types of meat.
3. With the trivet removed the food is placed directly on the base of the grill pan, eg when cooking dishes such as whole fish.

Always preheat the grill for 3 minutes for best results.

Equipment Details

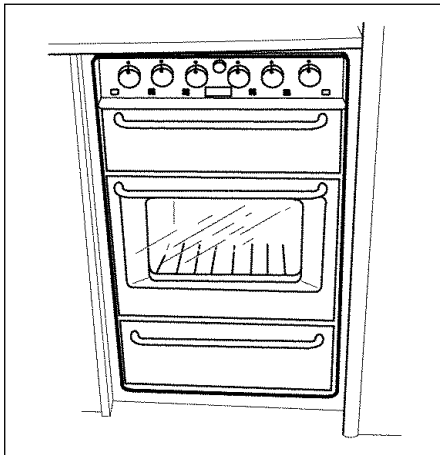

When you have finished grilling, check the control knob is in the off position

THE OVEN

Caution: When you are cooking, keep children away from the vicinity of the oven.

- **Important:** A safety device stops the ignition being used when the oven door is closed.
- Do not use foil on the oven shelves as this creates a fire hazard, and can hinder circulation of heat.

- Keep all flammable material away from the appliance.

To light the oven

1. Open the oven door and turn the control knob anticlockwise to the required gas mark. Push in and hold in the control knob, and either press the ignition button (if fitted) or use a hand held spark ignitor or gas lighter.
2. Once the burner has lit, close the oven door and hold the knob in for 15-20 seconds.
3. If the flame goes out, the flame sensing device cuts off the gas supply to the burner. To light the oven again, wait for 3 minutes then repeat the above procedure.

To turn off - Push in the control knob and turn clockwise.

Preheating

The oven must be preheated for 10 minutes when reheating frozen or chilled food, and we recommend preheating for all yeast mixtures, batters, soufflés and whisked sponges.

Using the oven

The shelf positions in the oven can be altered. If you prefer darker cooked results, cook on a higher shelf. For paler results use a lower shelf.

The cake tray and roasting tin that are supplied with this appliance are the largest which can be used for good results and even baking. Extra shelves, tins or trays can be ordered from your supplier.

Place food items on the tray and position the tray on the centre of the shelf, leaving one clear shelf position between shelves to allow for circulation of air.

CLEANING

Caution: Any cleaning agent used incorrectly may damage the appliance.

Always let the appliance cool before cleaning.

Some cooking operations generate a considerable amount of grease. This combined with spillage can become a hazard if allowed to accumulate on the appliance through lack of cleaning. In extreme cases this may amount to misuse of the appliance and could invalidate your guarantee.

Do not use caustic pastes, abrasive cleaning powders, coarse wire wool or any hard implements as they will damage the surfaces.

All parts of the appliance can be safely cleaned with a cloth wrung out in hot soapy water.

Equipment Details

Burner caps and heads

Important: Allow burners to cool before cleaning.

Caution: Hotplate burners can be damaged by soaking, automatic dishwashers (or dishwasher powders/liquids), caustic pastes, hard implements, coarse wire wool and abrasive cleaning pastes.

For the burners to work safely, the slots in the burner head, where the flames burn, need to be kept clear of deposit. Clean with a nylon brush, rinse and dry thoroughly.

Clean with a mild cream cleaner eg Cif, or use a moist soapy Brillo pad.

Note: Fixed burners (if fitted): Some versions incorporate fixed burners. These burners are secured to the hob with 2 screws. Fixed burners must be cleaned whilst in position. Make sure that the gap between the burner and the hotplate does not become blocked with grease.

Glass parts (if fitted)

DOOR PANELS, FACIA PANEL,
HOTPLATE LID

Do not use abrasive cleaners or polishes. Use a mild cream cleaner, eg Cif. Rinse thoroughly and dry with a soft cloth.

The inner door glass panel can be removed for cleaning. Open the door wide, hold the bottom and top edges and slide out.

When replacing the glass panel, hold it level and straight with the grooves in the door trims before sliding back in.

Painted, plastic and gold coloured parts

DOOR FRAME & HANDLES, CONTROL KNOBS

Only use a clean cloth wrung out in hot soapy water.

Vitreous enamel parts

GRILL PAN, HEATGUARD, OVEN/GRILL COMPARTMENT(S), HOB SPILLAGE WELL, PAN SUPPORTS

Use a mild cream cleaner. Look for one that has the Vitreous Enamel Council's recommendation seal, eg Cif.

Chrome plated parts (Fig 1)

GRILL GRID, SHELVES, SHELF RUNNERS

Do not use abrasives or polishes. Use a moist soap pad, eg Brillo. Shelf runners can be removed for cleaning. Grasp the runners and slide out of the hanging holes as shown in fig 1.

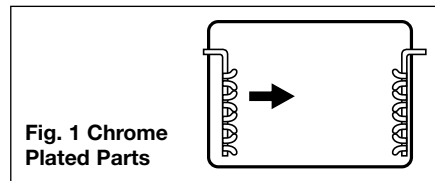

Stainless steel surfaces (stainless steel models only)

Only use a clean cloth wrung out in hot soapy water, and dry with a soft cloth. Do not use undiluted bleach or any products containing chlorides as they can permanently damage the steel.

Some foods are corrosive, eg vinegar, fruit juices and salt, and they can mark or damage stainless steel if they are left on the surface for any length of time. Wipe any spillage immediately.

Sharp objects can mark the surface of stainless steel but will become less noticeable with time.

Electric hotplates

Important: Ensure that elements are switched off and cool before cleaning

For normal cleaning use a clean damp cloth. For heavy cleaning, use a clean damp cloth or scouring pad with a cream cleaner.

Follow the circular grooved pattern on the hotplate. Rinse off any cleansing agent thoroughly, then switch on to a low-medium setting for few minutes to dry. When cleaning take care to avoid the red dot on the high speed hotplate (if fitted).

Equipment Details

DOMETIC EXTRACTOR FAN

The fan filter

The fan filter that absorbs grease in cooking fumes requires cleaning now and then. Exactly how often will of course depend on how much the cooker is used and for how long the fan is in operation. Do not wait until the suction power of the fan begins to decrease noticeably.

Cleaning can easily be carried out with hot water to which some synthetic detergent has been added.

To remove filter hold tab on right hand side of filter and push to left whilst pulling down. To refit put left hand end into recess then push up to engage lugs in slots in body.

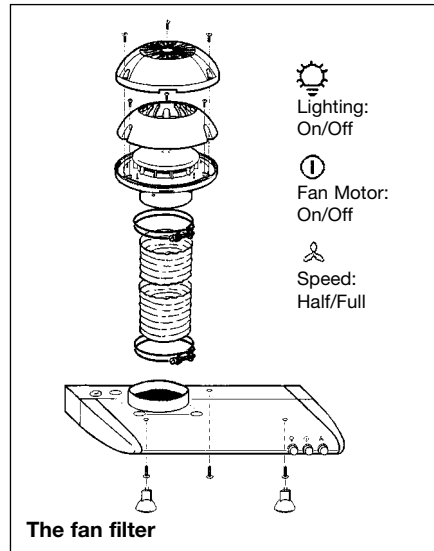

Equipment Details

SHARP R247 MICROWAVE OVEN

Please refer to the appliance manufacturers handbook regarding: - OPERATION, COOKING ADVICE, AFTERCARE and GUARANTEE

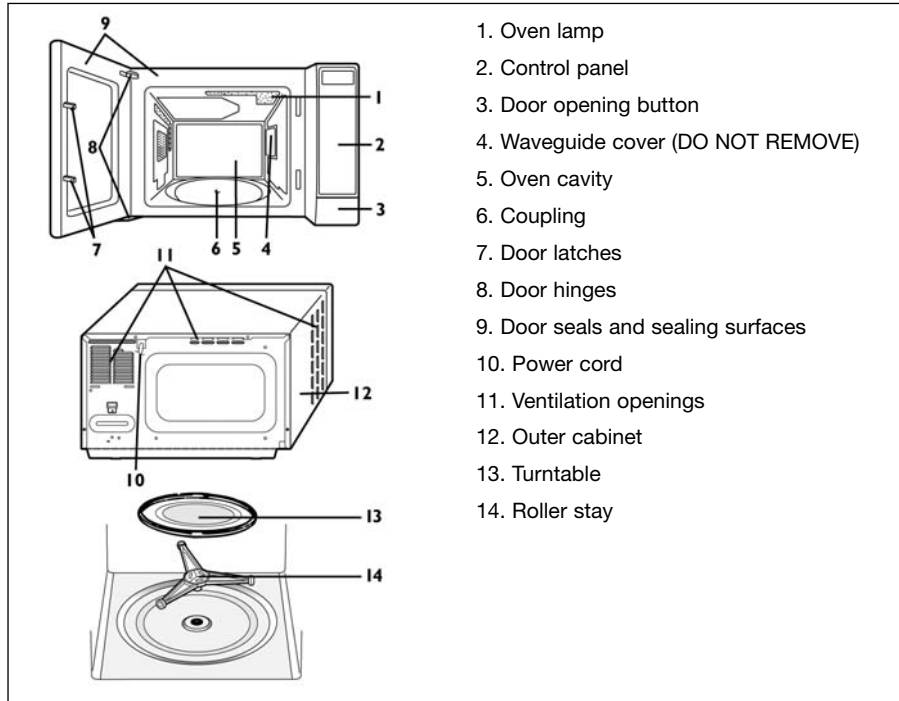

ELECTRICAL CONNECTION

- Do not allow water to come into contact with the power supply cord or plug.
- Insert the plug properly into the socket.
- Do not connect other appliances to the same socket using an adaptor plug.
- If the power supply cord is damaged, it must be replaced by a Sharp approved service facility or a similarly qualified person to avoid a hazard.
- When removing the plug from the socket always grip the plug, never the cord as this may damage the power supply cord and the connections inside the plug.
- If the plug fitted to your oven is a rewirable type and in the event of the socket outlet in your home not being compatible with the plug supplied, remove the plug properly (do not cut off).
- If the plug fitted to your oven is a non-rewirable type and in the event of the socket outlet in your home not being compatible with the plug supplied, cut-off the mains plug.
- Refit with a suitable type, observing the wiring code given in 'To replace the mains plug' on page 34 of the SHARP user instructions.

Equipment Details

IMPORTANT SAFETY INSTRUCTIONS

PLEASE READ CAREFULLY AND KEEP FOR FUTURE REFERENCE

OVEN USE:

- THE OVEN IS FOR DOMESTIC FOOD USE ONLY.
- NEVER OPERATE THE OVEN WHEN EMPTY.
- DO NOT LEAVE OR STORE ANYTHING INSIDE THE OVEN WHEN NOT IN USE.
- NEVER ATTEMPT TO USE THE OVEN WITH THE DOOR OPEN. IT IS IMPORTANT NOT TO FORCE OR TAMPER WITH THE DOOR SAFETY LATCHES.
- NEVER OPERATE THE OVEN WITH ANY OBJECT CAUGHT IN THE DOOR.
- DO NOT INSERT FINGERS OR OBJECTS IN THE HOLES OF THE DOOR LATCHES OR AIR-VENT OPENINGS AS THIS MAY DAMAGE THE OVEN AND CAUSE AN ELECTRIC SHOCK.
- IF WATER OR FOOD DROPS INSIDE THE AIR VENT OPENINGS SWITCH OFF THE OVEN IMMEDIATELY, UNPLUG IT AND CALL A SHARP APPROVED SERVICE FACILITY. (SEE PAGE 34 OF THE USER INSTRUCTIONS).

- NEVER MOVE THE OVEN WHILE IT IS OPERATING.
- NEVER PLACE ANY OBJECT SUCH AS A TEA TOWEL, ORNAMENT, RECIPE BOOK ETC IN ANY OF THE AIR GAPS BETWEEN THE MICROWAVE AND THE INSIDE FACE OF THE MICROWAVE

CABINET. CLEAR AIR GAPS AT THE TOP, BOTTOM AND BOTH ENDS ARE ESSENTIAL TO THE EFFICIENT OPERATION OF THE MICROWAVE.

PACEMAKER: IF YOU HAVE A HEART PACEMAKER, CONSULT YOUR DOCTOR OR THE PACEMAKER MANUFACTURER PRIOR TO OVEN USE.

MICROWAVE OVEN If factory fitted the specification is:		
Make	SHARP	
Model	R247	
Power supply	SINGLE PHASE 230-240V, 50Hz,	
Microwave	Power Consumption	1.21kW
	Input power	5.2A
	Output Power	800W (IEC 60705)
	Frequency	2450 MHz
Outside dimensions	460(W) x 275(H) x 360(D)mm	
Cavity dimensions	322 (W) x 187(H) x 336 (D)mm*	
Oven capacity	20 litre*	
Cooking uniformity	Turntable diameter 272mm	
Weight	Approx 12kg	
* Internal capacity is calculated by measuring maximum width, depth and height. Actual capacity for holding food is less.		
If fitting a Microwave DIY we recommend you purchase the above specification.		

ADVISORY NOTE FOR USERS OF A MICROWAVE OVEN

Microwave Ovens were originally introduced to re-heat pre-cooked pies etc. Over the years people started using them for re-heating ready made meals and now for they are used for cooking small amounts of food.

Most small microwaves, and some large microwaves, cease to cook the food when the microwave starts to overheat. This often occurs when batches of food are cooked consecutively.

Overheating is caused by a number of factors: -

- The heat generated within the Microwave.
- The Heat generated by an adjacent Oven, Hob or Fridge/Freezer, Radiator etc.
- The Heat generated in the environment due to the heating system and/or lack of ventilation etc.
- The mounting of the microwave in a housing.

It has been proven in independent tests that even when placed on a worktop in an open household kitchen environment a microwave will switch off, or the Magnetron will reduce its output, when the microwave starts to overheat.

This fact is exacerbated in a Caravan or Motorhome as space is at a premium. The microwave has to be placed in a cabinet to maximize the space available for all the family activities that take place in the modern Caravan and Motorhome. The housing also secures the microwave whilst travelling.

Frequently the above results in the Microwave being mounted above an Oven/Hob or a Fridge/Freezer.

When the Sharp Microwave starts to overheat, the magnetron automatically reduces its output but the Microwave still looks the same. The Light will stay on, the turntable will continue to rotate, the cooling fan will still operate and the timer will continue.

The above means that times quoted in recipes should be used for guidance only.

It is essential, when cooking with any microwave, that the food is examined to ensure that it is fully cooked before eating.

Equipment Details

THETFORD CASSETTE C-200 CW (Manual) and C-200 CWE (Electric)

FEATURES

1. Removable seat and cover.
2. Rotatable bowl.
3. Valve blade handle: opens and closes valve blade.
4. Flush-handle activates the flush by lifting and pushing down the handle.
- 4a **C-200 CWE.** Flush button: activates flush.
- 4b **C-200 CWE.** Valve blade buttons: open and close valve blade electronically.
5. Power-supply for the waste-level indicator: two batteries, type: Penlite 1,5V AA alkaline.
6. Waste-level indicator: indicates when holding tank requires emptying.
7. Rotating pour out spout: makes emptying holding tank easy and convenient.
8. Upper carrying handle
9. Automatic holding tank vent: vents the holding tank when the tank is inserted in the toilet. This prevents under- or overpressure in the holding tank.
10. Valve blade opener.
11. Sliding cover: closes automatically when holding tank is taken out. Guarantees optimal hygiene.
12. Valve-blade
13. Vent button: vents the holding tank to avoid splashing while emptying.
14. Hand grip
15. Access door
16. Waterfill door

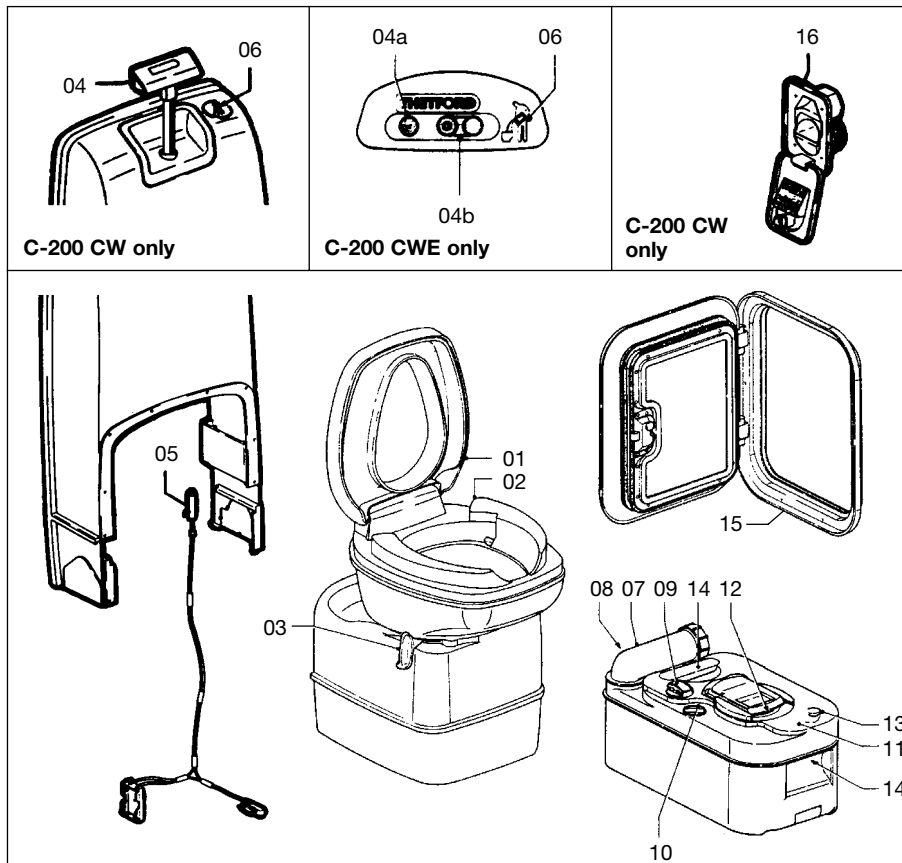

Equipment Details

CASSETTE C-200 CW AND C-200 CWE

The toilet section of the C-200 includes a rotatable bowl, removable seat and cover, a console with a flush handle/flush buttons, a built in flush-watertank and a waste level warning indicator. The valve blade handle is located underneath the bowl.

PREPARING FOR USE

1. Open access door pull retaining clip upwards (fig. 1).
2. Remove holding tank by pulling straight out. When holding tank hits the stop, tilt front end downwards slightly and remove (fig. 2).
3. Position tank vertically and swivel pour out spout upwards (fig. 3).
4. Remove the cap of the pour out spout. Add required quantity of toilet fluid through pour-out spout then add approx. 2 litres of water through the spout to cover holding tank bottom. Replace cap and return pour out spout to its original stored position (fig. 4).

Note: Warmer weather or longer intervals between emptying the waste tank may require additional toilet fluid. Use only Thetford toilet fluid to achieve the best results.

Caution: Never add toilet fluid directly into toilet bowl.

5. Slide the holding tank into position through access door (fig. 5).
6. Make sure the holding tank is secured by the retaining clip (fig. 6).
7. Open the waterfill door and add 50 ml of Aqua Rinse. Aqua Rinse results in a better flush and improves the hygiene of the toilet. Then fill the watertank with fresh water using a jerrycan or a hose. Tank capacity is 7 litres (fig. 7).

OPERATION

8. Turn the bowl in the most comfortable position (fig. 8).
9. **C-200 CW only:** Before using the toilet it is recommended to flush some water into the bowl by lifting and pressing down the flush handle (fig. 9).
- 9a. **C-200 CWE only:** Before using the toilet it is recommended to flush some water into the bowl by pressing and releasing the flush button (fig. 9a).

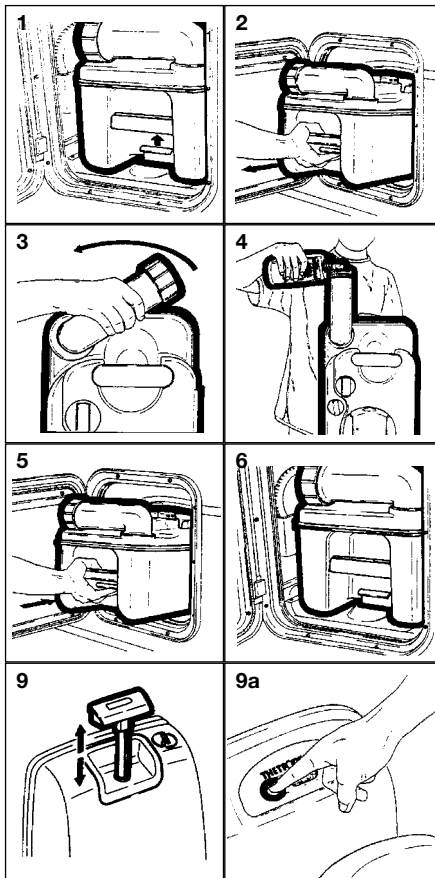
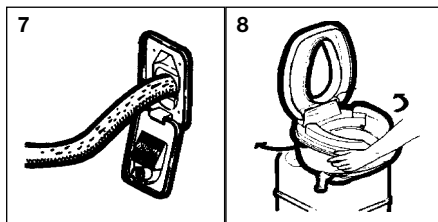

Equipment Details

10. After use open the blade by turning the blade-handle anti-clockwise (fig. 10).
- 10a. C-200 CWE only: After use open the blade by pressing the 'open' button (fig. 10a).
11. C-200 CW only: To flush, lift the flush handle and press it down (fig. 11). After flushing, close the blade by turning the blade handle clockwise.
- 11a. C-200 CWE only: To flush press the flush button (fig. 9a). After flushing, close the blade by pressing the close button on panel (fig. 11a).

The toilet may also be used with the valve blade open, which allows the waste to pass directly into the holding tank.

The waste holding tank is located underneath the toilet and is removed for emptying from the outside of the vehicle through an access door. A rotating pour out spout, automatic holding tank vent, air release valve, valve blade, carrying handles and hand grip are incorporated in the waste holding tank. A sliding cover guarantees optimal hygiene.

EMPTYING THE HOLDING TANK

The holding tank capacity is approx. 17 litres and the tank should be emptied when the waste-level indicator lights up. The waste-level indicator lights up when the holding tank contains more than 15 litres of waste.

CAUTION: Do not allow the holding tank to become overfilled. See trouble shooting section for emergency emptying procedure.

12. Open access door and remove the holding tank. The holding tank can only be removed when the valve blade is closed (fig. 12).
13. Carry the holding tank to a normal household type toilet or other authorised disposal point. Place the holding tank in vertical position and rotate pour out spout upwards (fig. 13).
14. Remove the spout cap. Grasp unit by upper carrying handle nearest to pour out spout. Place other hand on upper rear hand grip so that vent button can be depressed with the thumb while emptying. This ensures a smooth outflow of the tank contents. (fig. 14).

Note: Only depress the vent button when pour out spout is pointed downwards.

Rinse the holding tank with clean water. For preparing for use again, see steps 1 to 7.

CLEANING AND MAINTENANCE

The lipseal and the seal of the automatic vent are made of rubber and therefore these parts need regular maintenance (depending on frequency of use, once or twice a month).

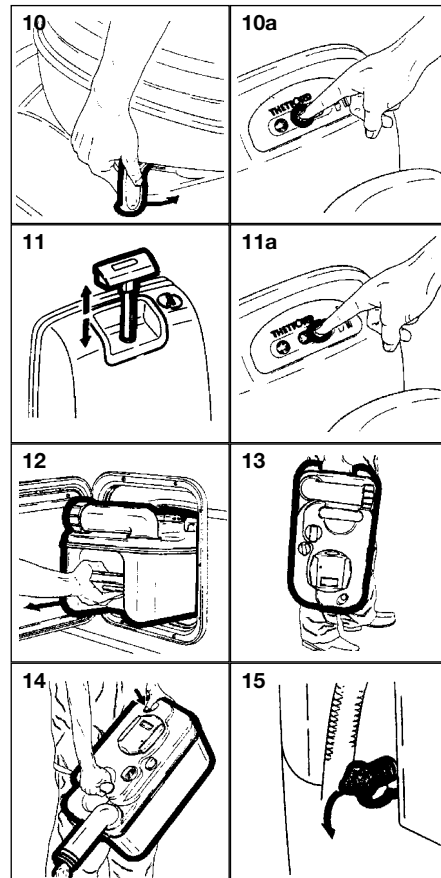

Lipseal: Remove the sliding cover. Open the valve-blade by turning the blade-opener knob anticlockwise. Clean the seal with water. Dry the seal and grease with silicone spray/oil or vegetable oil.

Seal of automatic vent: Turn the automatic vent 60° anticlockwise and remove gently. Clean the seal with water. Dry the seal and grease with silicone spray/oil or vegetable oil.

To clean the holding tank, empty the tank, and rinse with clean water. Use a mild soap to clean toilet bowl, seat and cover, as well as exterior of toilet unit and holding tank.

NOTE: Do not use strong household detergents or cleaners that contain chlorine, solvents or acid contents.

WINTERING/STORAGE

The Thetford Cassette C-200 CW/CWE is easily winterised for storage.

Empty remaining fresh water into the bowl by activating the flush handle up and down (C-200 CW) or by pressing the flush button (C-200 CWE).

Once pump has been cleared and water flow has stopped completely, release into waste tank. Remove waste tank and empty contents in normal way.

To evacuate any remaining water from the fresh water tank, place a container underneath the drainplug and remove drainplug.

When procedure has been completed replace drainplug and waste holding tank (fig. 15). Clean the seals and grease them after drying (see cleaning and maintenance).

Leave the blade of the holding tank open. Do not replace cap on the pour out spout, to ventilate the holding tank. (Also grease the seal of the pour out spout cap.)

COLD WEATHER USE

The toilet can be used in cold weather conditions provided that the toilet is in heated surroundings. If this is not the case, you can use a nontoxic antifreeze (propylene glycol) or an antifreeze such as those used in car radiators. Add the antifreeze to the water in the tank. Add the quantity specified in the instructions, paying due regard to the safety instructions.

HIGH ALTITUDE AND WARM WEATHER USE

Pressure may build up in the holding tank if the tank is not inserted while driving at high altitudes or in warm weather conditions. The automatic holding tank vent will vent the tank when there is over- or under-pressure. High temperatures may require additional Thetford toilet fluid.

THETFORD WARRANTY

1. The Thetford Cassette is warranted for one year from the date of purchase, please fill in and return the warranty card.
2. The warranty covers replacement of

defective or flawed parts and the inadequate performance of the toilet.

3. In case of a defect apply to an original dealer or Thetford Service Centre with proof of purchase.
4. Defects, which in our judgement occurred from misuse, negligence or accident, are not covered by the warranty. In addition, the warranty does not apply if the product is installed or handled improperly or if other than the prescribed toilet fluids have been used or if the product has been altered in any way or has been repaired by unqualified persons, or if the serial number and/or date has been altered or removed.
5. Should the original buyer wish to return to us parts believed to be defective, the parts should be sent prepaid. If we find the parts defective and covered by warranty, they will be repaired and returned. If warranty does not apply or has expired, a nominal charge will be made. Any transport costs are for the account of the owner.
6. Before returning product or parts they should be properly cleaned, in order to carry out inspection and repair.
7. No other warranty is given and no personal representative is authorised to make any warranty other than that is contained herein.

Equipment Details

SIDE LOCKERS

Some models are provided with exterior access locker doors. These are suitable for storing external equipment.



Side Locker

BUNK AND LUTON BED SAFETY

Where the sleeping surface is over one metre above floor level the following notices apply.

WARNING: Always ensure safety boards are located before entering the bunk.

WARNING: Use upper bunks for sleeping only, with the provided protection against fall out in position.

WARNING: Care shall be taken against the risk of fall out when the upper bunks are being used by children, especially under 6 years of age, these bunks are not suitable for use by infants without supervision.

SEAT SWIVEL (Driver/Passenger)



Front Swivel Seat

To turn the swivel, slide the RED lever rearwards and adjust to the required angle.

Before driving off ensure the locking mechanism is fully secure.

FREE STANDING TABLE

Note: The free standing table legs have a positive locking mechanism. Care must be taken to ensure that, when folded, the leg which is closed first locks into the second position.

When engaging legs in down position the mechanism must be positively locked down.

CAUTION!

When erecting the free standing table, be careful to avoid trapping fingers.



Equipment Details



To lock the table, raise the table 45°, push clip to rail and lower table.

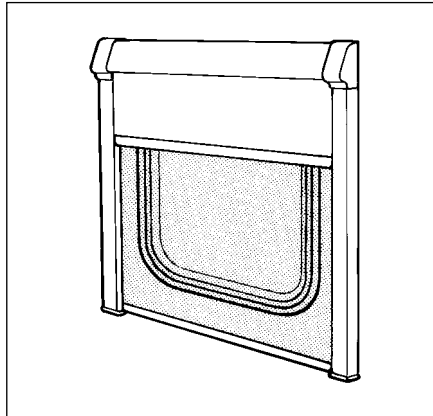

KOMFORTROLLO BLINDS (SEITZ)

Blinds and Flyscreens

Flyscreen and blinds operate in the same manner. The flyscreen can only be 'fully up' or 'fully' down, but the blind also has an intermediate position.

To operate, pull down by holding the fingerrip(s), gently ease towards the window to locate the catches. To retract, pull down easing away from the window to release the catches and guide to the required position.

- ONLY OPERATE BY HOLDING THE FINGERGRIP(S) - pulling on one side will cause uneven running and snagging.

- DO NOT ALLOW THE BLIND OR FLYSCREEN TO RE-COIL WITHOUT CONTROL.
- It is not recommended that blinds and/or flyscreens are left in the down position for long periods, or when travelling, as this can result in fatigue of the spring.
- Clean the cassette, side track and fabrics with mild detergent and water.
- Lubrication of mechanism or spring is not required or recommended. However, if components should require cleaning, use only WD40 or similar with fluff-free cloth. Other lubricants may result in damage to fabrics and plastics.

Tension Adjustment

Remove plastic cover (if fitted) to locate tension lugs. The tension lugs have a slot and are located in the cassette on a 'bayonet' principle. Insert screwdriver into slot (ensure a good fit), turn lug clockwise to allow the spring tension to push the lugs just free of the cassette. Keep fingers away from screwdriver tip to avoid accidental injury. Spring can now have more or less tension applied as required.

If in doubt of tension to be applied, release all tension and re-start. In which case, with blind fully wound on the roller, apply 12 revolutions of lug (factory setting).

Refitting is a reversal of removal procedure. For more detailed information, see manufacturer's instructions.



Freestanding table mechanism

Equipment Details

Cassette Blind and Flyscreen

Always hold the end rod in the middle. When closing blinds, slide the end rod of the flyscreen blind on to the end rod of the sun blind and engage. To open the blind push the end rods towards the darkening blind to the edge and disengage the end rods. Now move the end rod of the flyscreen back by hand - do not let it recoil.

WINDOWS

To open turn catches through 90°. Swivel the pane open as required.

To close the window, open the window as far as possible and slowly close again, turn the catches through 90° to close.

All opening windows have two catch positions. The first position is for ventilation the second seals the window from ventilation and rain.

ROOF LIGHTS

When opening the roof lights, care must be taken to release the locking mechanism as the unit is raised.

Roof lights must be fully closed when driving. 400 x 400 roof lights provide essential fixed levels of ventilation.

MINI HEKI ROOFLIGHT

To open depress button and push bar upwards. The rooflight has two open ventilation positions and a fully open position.

The blind and flynet operate independently of each other and are engaged by connecting to each other and sliding.

HEKI-2 ROOF LIGHT (SEITZ)

The lift/tilt roof light can be set in 3 positions by means of pneumatic springs.

Position 1 lifts the pane 12mm without allowing rain to enter the motorhome.

Position 2 sets the pane to a 150mm opening and locks with a bar.

Position 3 opens the pane through 55°.

A fully adjustable flyscreen and black-out screen are built into the inner frame. The flyscreen can be drawn independently and the black-out screen is variable for partial or full black-out.

Forced ventilation functions via a brush lined duct instead of a ventilated pane.

A cover hood can be fitted for winter protection.

Heki-2 roof lights provide 13,200mm² of fixed ventilation.

Close the roof light completely before driving.

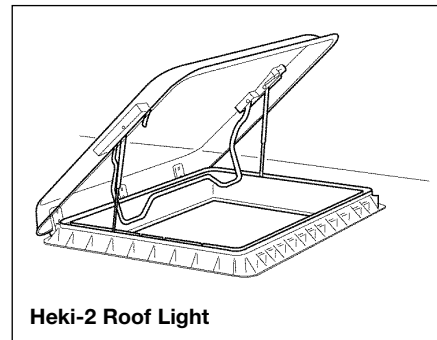

Heki-2 Roof Light

Do not operate whilst the vehicle is moving.

Do not stand on the roof light.

Do not leave your vehicle whilst the roof light is open.

HEKI-3 ROOF LIGHT (SEITZ)

OPERATING INSTRUCTIONS

Opening/closing the acrylic dome (Fig. 1)

To open, turn the crank until a resistance is felt (maximum opening angle - 70 degrees)

To close, turn the crank until the acrylic dome is lying flat, then turn the crank for another 2-3 turns to lock the rooflight completely. To check whether the rooflight is properly locked, try to push the acrylic dome upwards with your hand.

Opening/closing the blind and fly-net (Fig. 2)

Closing

- Pull the end rod (without the catch/blind) from the recessed part and engage it with the opposite end rod with the catch.

Opening

- Push the united end rods until the blind is fully extended. Press the catch and guide the blind back to its original position in the frame. (do not let the blind recoil)

Adjusting (Fig. 3)

Push the united rods until the desired setting is reached.

Attention: When there is strong sunshine, the blind should be closed only to 2/3 (the heat trapped between the blind and the acrylic dome could damage plastic components).



Fig. 1

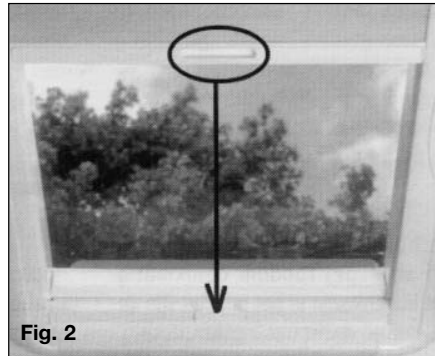

Fig. 2

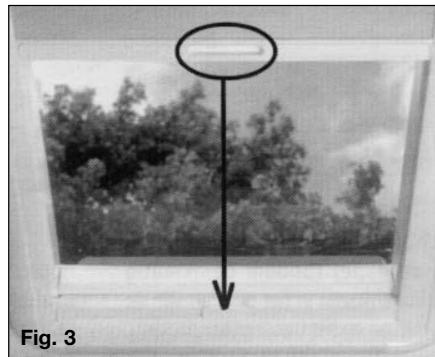

Fig. 3

Safety precautions:

1. Repairs should be carried out only by trained personnel.
2. Inform an approved dealer in case of defects and malfunctions.
3. Before starting off, check the rooflight for damage in the acrylic dome (tension cracks) and the winding mechanism which could arise owing to, for example, branches and other natural causes.
4. Do not step in the acrylic dome.
5. Close the roof light before starting off (check whether it is locked).
6. Do not leave the vehicle with the rooflight open (danger of burglary or from rain).
7. Do not open in strong wind or rain.
8. Before opening, remove snow, ice, dirt, etc. from the acrylic dome.
9. Malfunctions are to be repaired by an approved dealer at once.
10. Do not use caustic detergents (danger of tension cracks in the acrylic dome).

Care instructions:

- Please clean the acrylic panes with the Seitz Acrylic Cleaner.
- Stains and light scratches on the acrylic pane can be removed by using the Seitz Acrylic Polish and the Seitz special polishing cloth.

Equipment Details

- Use talcum powder (4 times yearly) to care for the rubber seals
- Clean the blinds only with water and mild soap suds
- The guarantee becomes null and void if these instructions are not followed.

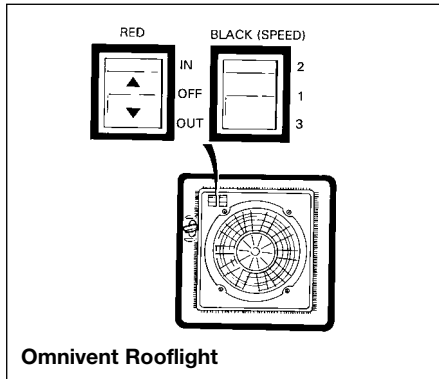

THE OMNIVENT (12V) ROOFLIGHT

The Omnivent is a double glazed rooflight constructed from a synthetic ultra-violet screened material. Its side operating mechanism allows a completely free central opening with built-in fixed ventilation when closed.

Red Switch = Mode of Operation

Induction (IN)
Expel (OUT)

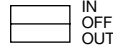

Black Switch = Speed Control

1, 2 and 3

Omnivents give no fixed ventilation when set on induction.

SHOWER

When using the shower, always ensure that the shower door is fully closed thus avoiding water spray on unprotected areas.

12V READING LAMP

Care should be taken when making directional adjustment, metal lamps when in use become very hot.

OMNISTEP SLIDE-OUT STEP

OPERATION

- The OMNISTEP is operated by the lever switch.
- Check if the step is retracted before departure.

MAINTENANCE

Dirt and frost can prevent the step from operating properly. In this case the rails and moving parts should be cleaned or defrosted.

IN CASE OF ELECTRIC BREAK DOWN

If the step does not retract by the motor

- Remove the front plate of the step. (Fig. 1)
- Remove the connection between the footboard and the arms (with screwdriver and wrench S10). (Fig. 2)
- Slide out the footboard.
- Reinstall the front plate.

CURRENT DRAWN

- Working current: 5 A
- Blocking current, when fully extended or retracted: 14 A

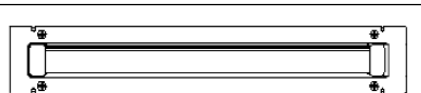

Fig. 1 Front Plate

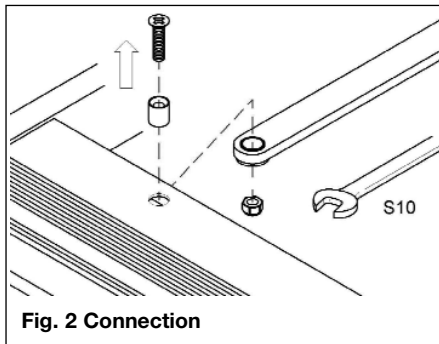

Fig. 2 Connection

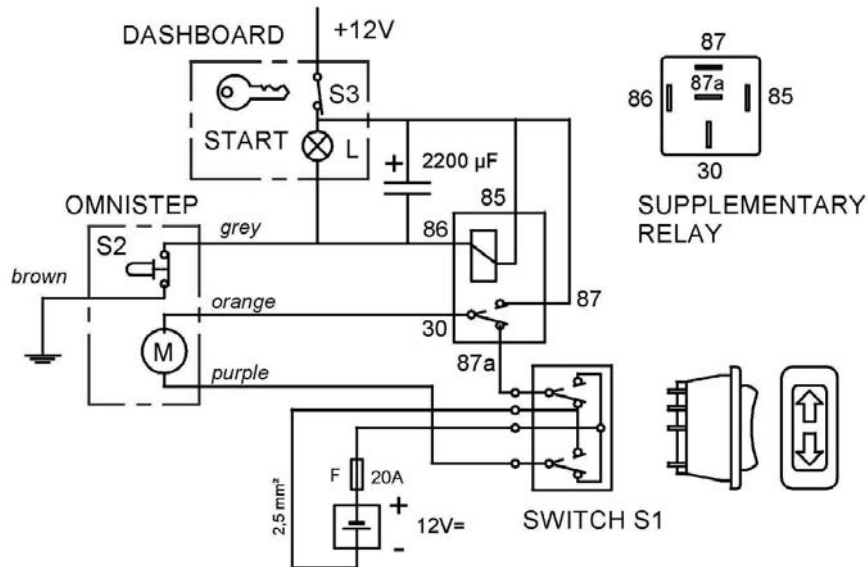

Fig. 3 Wiring Diagram

Equipment Details

OMNISTEP DOUBLE STEP

OPERATION

- The OMNISTEP is operated by the lever switch.
- **IMPORTANT:** When extending the step, hold the switch until the step is completely extended. **NEVER MOUNT THE STEP IF RETRACTED OR IF NOT FULLY EXTENDED**, because then the blocking is not working and the motor can be damaged.
- Check if the step is retracted before departure.

MAINTENANCE

Dirt and frost can prevent the step from operating properly. In this case the moving parts should be cleaned or defrosted. All points of movement are layered in maintenance-free bearings.

IN CASE OF ELECTRICAL BREAK DOWN

If the step does not retract by motor:

- Loosen the square connection according to fig. 2 (actions 1, 2 and 3), push the footboard in (4) and tie it to the frame (fig. 3).

CURRENT DRAWN

- 7 A. When fully extended or retracted: 19 A

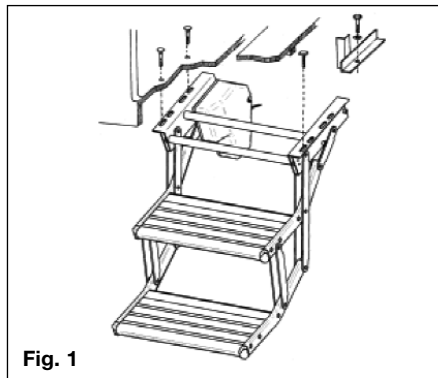

Fig. 1

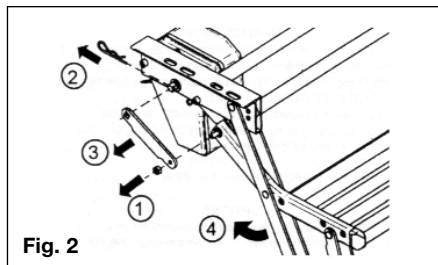

Fig. 2

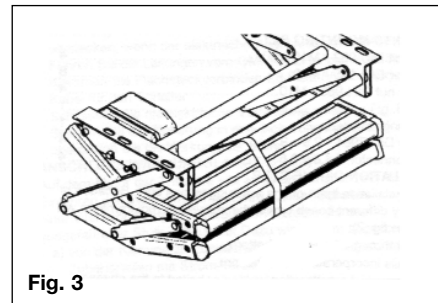

Fig. 3

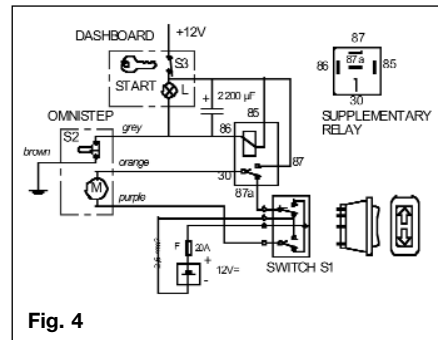
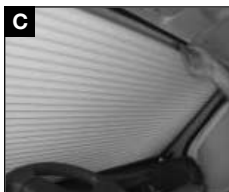

Fig. 4

CAB SCREENS

Front system

- Lift the arms of both sides and clip them to the A-pillar. (Fig. A)
- Adjust the main cab mirror parallel with the window screen. Take the blind trim in the middle and carefully pull it upwards in front of the mirror to the required position. (Fig. B & C)
- Reverse procedure when opening.
- When travelling always secure the arms with the attached strap.



Side system (model dependant)

- Take the trim by tilting and pulling slightly from its position. (Fig. D)
- Pull down the trim as shown (Fig. E) bringing the trim into the gap of the frame until the magnet closes. (Fig. F)
- Take the trim by tilting and pulling slightly from its position. Close the blackout and close the trim with the magnets. (Fig. G)

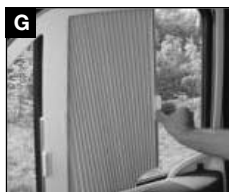

- **To open the blackout**, take the trim by tilting slightly to open the magnet. Form a U with your hand and bring back the pleated material in its position.
- Press the trim to the frame and secure. (Fig. H)
- To open the blackout, hold the trim tilting slightly to open the magnet. Form a U with your hand and bring back the pleated material in its position. (Fig. I)



Equipment Details

STATUS 315 OMNI-DIRECTIONAL TV AND FM RADIO ANTENNA (model dependant)

OPERATING THE SYSTEM

- Switch on the Power Pack and the red LED will illuminate.
- Check the gain control switch is set to the normal 'NML' position (Switch Up).
- Turn on your television set and tune in. This may be necessary at all new locations.

REMOVING THE ANTENNA

- A permanently fitted Status may be removed if there are severe height restrictions, leaving only the mounting foot in place.
- Unplug the antenna from the Power pack. On the adapter, loosen the two grub screws and lift off whilst carefully feeding out the coaxial cable with the plug attached.
- Push the blanking cap supplied into place to cover central hole

REMOVING THE PINNACLE

This may be necessary should you wish to reduce the overall height of the antenna by 90mm.

- Simply unscrew the Pinnacle and remove. The antenna is designed to remain watertight without the Pinnacle
- To replace, simply screw in and tighten BY HAND

IMPORTANT – The Pinnacle is an integral part of the antenna and critical to its performance. When in use always ensure the Pinnacle is fitted.

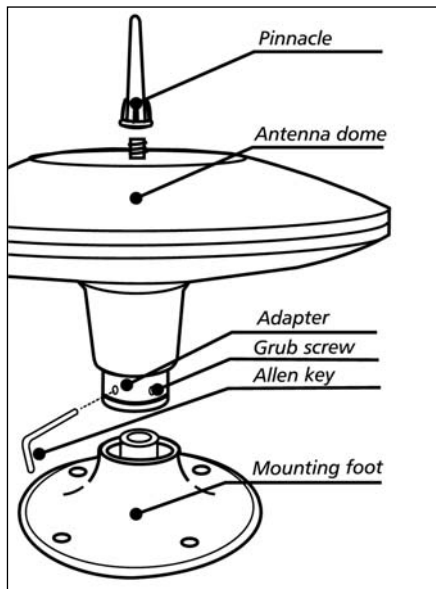

STATUS 530 DIRECTIONAL TV AND FM RADIO ANTENNA (model dependant)

Firstly determine the approximate location of the nearest transmitter and whether the signals are horizontally or vertically polarized. For assistance ask your site operator or check antennas in the vicinity

1. Loosen the Mast Locking Collar and Wall Bracket and raise the antenna. Turn the mast to direct the Antenna towards the TV transmitter.

The RED spot on the bottom of the mast indicates the front of the Antenna.

2. When receiving vertically polarized signals, rotate the winder anti-clockwise to cant the antenna through 90°. DO NOT over tighten or use undue force on the winder.

DO NOT cant for vertically polarized signals with the TELESCOPICS EXTENDED

3. Switch ON the Power Pack and the RED LED will illuminate.
4. Check the gain control switch is set to normal – NML.
5. Tune your television to the strongest signal. You may need to adjust the direction of the mast to achieve the best quality picture.

- Secure by tightening the Mast Locking Collar and Wall Bracket

REMOVING THE ANTENNA

A permanently fitted Status can be easily removed leaving only the Mounting Foot and rubber gaiter.

- Unplug the antenna from the Power Pack.
- Loosen the Mast Locking Collar and Wall Bracket and lift off whilst feeding out the cable.
- Push the Blanking Cap supplied into place.

IMPORTANT – The Blanking Cap is a temporary seal and is not for long term use.

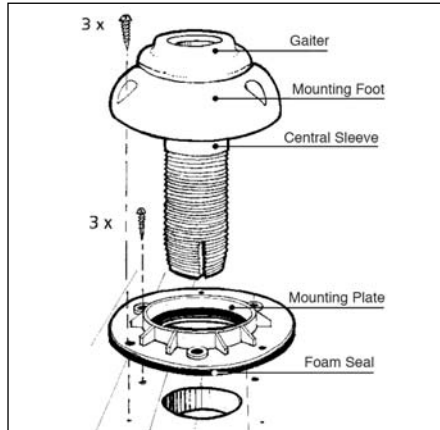

FIAMMA F45i SIDE AWNING

- In order to avoid unnecessary strain on the awning as well as on the vehicle side, we suggest that the legs be extended about 1m from the opening.

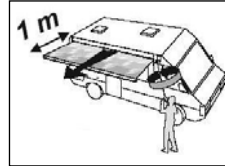

- Unscrew the leg knob to slide the leg out of its seat.

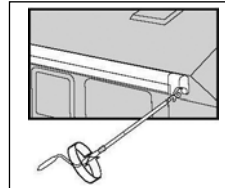

- Grasp the leg near its hinge-joint and pull it in a horizontal direction.

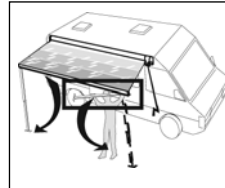

- Lower the leg as shown in the figure.

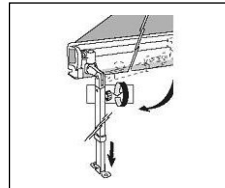

Equipment Details

- After unrolling the awning completely, adjust the legs at the chosen height.

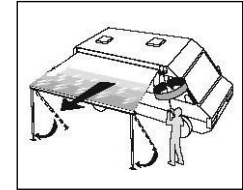

- To avoid that the awning is lifted up by an unexpected gust of wind, it is necessary to secure the legs to the ground with the provided hooks. For greater safety, we strongly advise you also use some storm cords in the upper part of each support leg or anchor the awning with the Fiamma Tie-Down Kit strap.

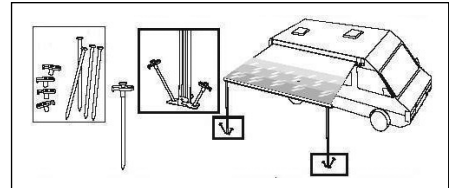

- If you want to fasten the support legs to the vehicle, put the terminals into the wall brackets. The brackets can be fixed only in reinforced points.

Equipment Details

CAUTION: - SWIFT RECOMMEND THAT THE AWNING BE GROUND MOUNTED ONLY.

SIDE MOUNTING BRACKETS ARE SUPPLIED. BUT IN INCLEMENT WEATHER CONDITIONS MAY CAUSE DAMAGE TO THE MOTORHOME BODYWORK

CAUTION: - THE AWNING IS A SUN PROTECTION, PLEASE ROLL UP YOUR AWNING IN CASE OF RAIN, WIND OR SNOW.

ALTERNATIVELY LOWER ONE SIDE OF YOUR AWNING, SO THAT WATER CAN FLOW AWAY AND ASSEMBLE THE TENSION RAFTER AS SHOWN IN THE FIGURE (NOT INCLUDED FOR ALL AWNING LENGTHS).

RAFTER PRO

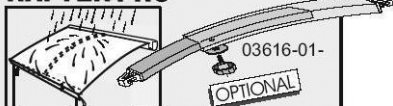

ATTENTION: we suggest that tension rafter PRO be used only temporarily.

- Make sure that the awning perfectly rolls up: when it is, the red indicators on the front profile ends are no longer visible. A damaged fabric does not allow the awning to perfectly roll up. Never use the awning with a damaged canopy. Wash the canopy with Fiamma BRILL.

NOTE: In case of problems refer to the user manual or contact your dealer.

DVD / AV OUTPUT SOCKET



Comprising of three sockets for phono plugs, has been located in the primary TV position within your motorhome. The socket provides video and left and right audio channel output to connect to a television with suitable input connectors (Please see the instructions supplied with the television for details). A suitable cable (not supplied) will be required to connect between the

socket and television. In order to use the socket, a suitable DVD player must be fitted to the motorhome. The connections for the player can be found under the passenger seat base in the cab of the motorhome, and comprises of three phono plugs.

OBSERVE REVERSING CAMERA/ MONITOR (IF FITTED)

Please refer to the user instructions provided.

SATILITE NAVAGATION WITH REVERSING CAMERA PROVISION (IF FITTED)

Please refer to the user instructions provided.

CD TUNER

Please refer to the user instructions provided with the Fiat documents.

REVERSING CAMERA/MONITOR IS SUPPLIED AS A SECONDARY AID TO ASSIST THE DRIVER WHEN REVERSING.

IT IS ILLEGAL FOR THE MONITOR TO BE USED WHILST TRAVELLING IN THE FORWARD POSITION

MOTORHOME CARE

Modifications - DIY	108
Motorhome Exterior	108
Motorhome Interior	109
Chassis and Rear Axle	110
AL-Ko Exhaust System	110
Winterisation/Storage	110
Caring for the Environment	111

Motorhome Care

MODIFICATIONS - DIY WORK

Owners need to be aware that carrying out DIY modifications to your motorhome may in certain instances, invalidate the warranty cover and could also affect the safety and structure of the motorhome.

Before carrying out any DIY work within the warranty period (3/5) years please check with your nearest Swift Group dealer or contact Supercare customer services on 01482 875740 for advice.

WARNING: In the interest of safety, replacement parts for an appliance shall conform to the appliance manufacturer's specification and should be fitted by him or his authorised agent.

MOTORHOME EXTERIOR

PAINTWORK

The exterior of your coachbuilt motorhome is finished with glass reinforced plastic (GRP) which is very durable and easy to clean owing to its smooth finish. GRP is now used extensively in modern motorhome construction and if cared for properly will enhance the appearance of your vehicle. To maintain a showroom finish wash the motorhome regularly with a mild detergent, rinse with cold water and leather off. A good

quality, silicon free car wax may be applied which will make washing even easier.

Under no circumstances use any abrasive cleaning agents on the exterior of your motorhome. Stubborn stains may be removed by using a soft cloth and a mild detergent.

WARNING: Overzealous use of detergents may loosen the decals and/or badges.

WARNING: Care should be taken as the silicon in some polishes can attack the rubber used on the exterior for seals and gaskets.

MOULDINGS

Some mouldings are anodised aluminium and will retain their lustre for a long period if no abrasive materials are used to clean them. If your motorhome is subjected to constant changes of temperature, mastic may seep from joints between the mouldings. Any excess that appears can be removed by simply wiping with a soft cloth.

WARNING: Do not wash motorhome with a high pressure washer. These can cause permanent damage to the seals of your motorhome.

ACRYLIC WINDOWS

The windows in your motorhome are fully double glazed and with care will remain sparkling and scratch-free.

Keeping your acrylic windows sparkling:

Small Scratches: For small scratches use a liquid metal polish or a proprietary acrylic polish of a suitable grade dependent upon the severity of the scratches.

Cleaning: Wash down as you would your car. Do not use a sponge on dirty windows. When all dirt has been removed, dry with a leather or similar type cloth. The catches and stays do not require lubricating.

Removing Tar: Use a proprietary tar remover on your double glazed windows, it is obtainable from most leading car accessory or Do-It-Yourself shops. Do not use petrol or other chemicals.

MOTORHOME INTERIOR

SIDE WALLS AND ROOF LINING

A simple wipe over with a damp cloth and a very mild detergent is all that is needed.

SOFT FURNISHINGS

These should be vacuumed occasionally to remove grit and sand and help to keep its smart appearance and ensure long life. The upholstery can be cleaned with a mild, reputable upholstery cleaner. It is recommended that the curtains are dry cleaned only.

WORK SURFACES

Work surfaces are made with heat resistant tops.

Note: You should not stand very hot items on any of the work surfaces, especially models with plastic moulded sink and drainers.

CUPBOARD CATCHES

It is advisable to lightly oil all cupboard catches, sliding bolts, telescopic bed slides and hinges from time to time.

BATHROOM, SHOWER ROOM AND KITCHEN EQUIPMENT

All the Thermoplastic parts in these areas have easy clean surfaces. To ensure long life and prevent damage you must not use any cleaning materials at all and ensure water temperatures do not exceed 70°C, (putting cold water in first is suggested). After every use it is essential that you rinse with clean water only and wipe with a soft damp cloth. Failure to follow these simple instructions may result in premature failure or cracking which will not be covered by any guarantees (including extended warranties).

To improve the appearance of your shower duck board (model specific), lightly brush occasionally with vegetable oil.

CONDENSATION

Condensation will always occur when humidity inside your motorhome exceeds 60 per cent. Correct heating and ventilating of your motorhome will help to control condensation. We therefore recommend that you make sure your motorhome is heated and ventilated correctly at all times of the year, particularly in inclement or very wet weather. It will assist in reducing condensation if the windows are left in the night latch position.

FURNITURE

A simple wipe over with a damp cloth should be all that is required. Polishing with a proprietary brand of wax polish enhances and maintains furniture in showroom condition. Follow these guidelines to ensure your investment is receiving the very best attention.

It must be remembered that because the frames of some doors are made of ash, which is a natural product, they can be affected by temperature and humidity and may bow under certain conditions. As conditions change they may revert to their original positions.

Motorhome Care

CHASSIS AND REAR AXLE

Some models are built on Fiat Ducato base vehicles, the chassis of which has been converted by AL-KO. This conversion provides a hot dipped galvanised steel chassis coupled with a wide track rear axle utilising steel torsion bar suspension, imparting vastly improved stability and road holding.

AL-KO EXHAUST SYSTEM

A standard Fiat exhaust system is fitted utilising an AL-KO modified tail pipe, available through your approved dealer.

A standard Fiat exhaust system is fitted to all other models, with the addition of a Swift Group tail pipe.

WINTERISATION/STORAGE

This is probably an opportune moment to arrange for the motorhome to have its annual service at your appointed dealer.

The following applies wherever your motorhome is stored particularly during the winter months.

Do not park near trees or larch type fences, due to possible wind damage.

Keep any grass around the floor of the motorhome short, to maintain air flow and stop any possible damp getting into the motorhome.

It is advised that the motorhome is ventilated regularly throughout the winterisation/storage period, opening windows, doors and rooflight when possible.

General

All moving parts should be checked for free operation.

Clean all cooking appliances and refrigerator.

Lubrication should be carried out at the points illustrated in the general notes on chassis maintenance.

Charge the on-board battery every 2 months.

Leave the refrigerator door open.

Leave furniture doors and lockers open to allow air to circulate fully.

Soft Furnishings

Clean and dust the upholstery and if possible remove before placing the motorhome into winter storage. Alternatively, stand the cushions on their edges to allow circulation of air. This will reduce the possibility of dampness from condensation.

Keep curtains or blinds closed, to minimise fading of furniture.

Wheels and Tyres

Do not store in one position with partially deflated tyres. The tyre walls will suffer and present a real danger of blow outs,

especially when travelling at faster speeds than are allowed in the UK.

The wheels should be turned every couple of weeks.

If you are removing the wheels, follow the jacking procedure for changing a wheel.

Water System

Ensure water pump is turned off.

Lift kitchen sink unit lid and clip in open position.

All single lever mixer taps, including the shower control, should have the lever moved to the central position and lifted to the open position for hot and cold.

All conventional taps should be opened.

Remove shower head and place in the kitchen drawer. Let the shower hose drain into the shower tray and then return to holder.

Drain water tanks:

Fresh tank: remove the water dump plug inside the tank

Waste tank: open inline valve adjacent to the tank. Valve is open when handle is in line with valve.

Drain water heater:

Truma Store and Combi boilers - open yellow handle on inline valve adjacent to heater. Valve is open when yellow handle is vertical.

The Thetford Cassette porta potti is easily winterised for storage. Empty the fresh water tank using the drain tube/fresh water tank level indicator (level indicator on electronic models only). Pull the lever indicator/drain tube down from top plug position and outward through door opening to drain water from the tank.

Empty the water fill funnel by pulling the bottle away from tank. Remove the small water cap on the filler bottom, allowing water to drain from the water funnel.

Do not tighten caps, this helps in keeping unit dry.

The pour out spout and vent plug can be removed. Seals should be greased if necessary with acid-free vaseline.

Remove the drain stop plugs on the fresh water pipes. These are located through the floor on the underside of the motorhome.

If a fresh water tank is fitted, drain the tank via underfloor drain tap/plug.

Leave the drain plugs and taps open.

The motorhome may be left in this condition over winter or until ready to use. It is recommended to leave the taps in the open position during storage.

Recommissioning the Water System

Fill the fresh water tank on the Thetford Cassette porta potti (certain models only) using a hose or jerrycan until the water in the funnel reaches the neck. Tank capacity is 15 litres. Aqua Rinse may be added to improve cleaning of bowl and flushing of unit. Replace cap. Swing back the water fill funnel until it touches the water tank.

Add Aqua Kem (100 ml) into the Cassette (or 120 ml if using Aqua Kem Bio) through the pour out spout. Add small amount of water through the pour out spout and replace the cap.

Close the cold taps and ensure all the drain plugs are fitted.

It is advisable after storage to flush the water system initially with a sterilising agent (such as Milton), and then with water repeating until the system is well flushed through.

Connect the pump.

Fill the system with water until water flows freely from the hot taps. About 2 gallons of water will be required. Close the hot taps.

Appliances

Before starting motor caravanning after storage, check all gas appliances and electrical points.

Note: Preferably not less than once a year, the electrical installation should be inspected and tested by a qualified electrician.

After storage it is advisable to air the motorhome and clean throughout, especially cooking appliances and the refrigerator.

Replace the bedding and wheels if they were removed for storage.

Important

Always follow the manufacturer's recommended procedures after use of fitted equipment in the motorhome and before storing for any length of time.

CARING FOR THE ENVIRONMENT

After many years of service you may decide that your motorhome has become beyond economic repair and should be disposed of. Please ensure that you comply with the end of life vehicle legislation and take it to an authorised treatment facility where it will be properly dealt with to minimise any negative environmental impact. The transaction will be logged at the DVLA, identifying that you are no longer the owner of the vehicle.

USEFUL INFORMATION

Owners Club	114
Spares and After Sales Supercare	114
Repair Facilities	114
Caravan Clubs	115
Motoring Organisations	115
Trade Association.....	115

Useful Information

MOTORHOME INFORMATION

Date of purchase

Supplying dealer

CAB Chassis No

Motorhome Serial No

OWNERS CLUB

The Owners Club is a completely independent organisation run for the benefit of the motorhome owners. They have numerous rallies during the year in various parts of the country and every third year there is a 'Works Rally' where owners have the opportunity to visit the factory. Apart from the friendliness and companionship the Club generates it is also actively engaged in charity work for those less fortunate than ourselves. The address of the Secretary of the Owners Club can be obtained from Supercare (SML Ltd), Tel: 01482 875740 or from the Swift Group website.

SPARES AND AFTER SALES SUPERCARE

There are numerous items available from your dealer ranging from door catches through to spare wheels and touch-up paints. Please note that all after sales enquiries must be directed through your supplying dealer. The after sales service at the factory is geared to support our dealer network as is the service provided by appliance manufacturers.

In the interest of safety, replacement parts for an appliance shall conform to the appliance manufacturer's specifications and should be fitted by them or their authorised agents.

Note: Please remember to quote chassis number when ordering any items from your dealer.

Customer Care

Tel: 01482 875740

Fax: 01482 840082

NOTE:

The times for contacting Customer Care by telephone are:

9am to 4pm Monday to Thursday.

9am to 12.45pm Friday.

Swift Group Website

www.swiftleisure.co.uk

Swift Group E-Mail Enquiry

enquiry@swiftleisure.co.uk

REPAIR FACILITIES

Should you be unfortunate enough to suffer a major accident with your motorhome it is comforting to know that we have a completely separate repair shop facility where their fully trained experts will undertake all types of major damage repair work.

Repairs of a minor nature should be referred first to your local dealer.

The enjoyment of your motorhome can be greatly enhanced by membership of one or more of the various caravanning, motoring and holiday clubs. Here are some useful addresses:

CARAVAN CLUBS

The Caravan Club,

East Grinstead House,
East Grinstead
West Sussex, RH19 IUA
Tel: 01342 326944
www.caravanclub.co.uk

The Camping and Caravanning Club,

Greenfields House,
Westwood Way,
Coventry,
West Midlands.
Tel: 01203 694995
www.campingandcaravanningclub.co.uk

MOTORING ASSOCIATIONS

Automobile Association (AA)

Fanum House,
Basingstoke,
Hants. RG1 2EA
Tel: 0990 448866
www.theaa.co.uk
e-mail: customer.services@theaa.com

RAC Motoring Services

RAC House,
M1 Cross,
Brent Terrace,
London, NW2 1BX
Tel: 0990 722722
www.rac.co.uk

Green Flag National Breakdown

PO Box 300,
1, Cote Lane,
Leeds, LS99 2LZ
Tel: 0345 670345

TRADE ASSOCIATION

National Caravan Council

Catherine House,
Victoria Road,
Aldershot,
Hampshire, GU11 1SS
Tel: 01252 318251
www.martex.co.uk/ncc
e-mail: mail@martex.co.uk

MINDER

HPI Equifax

Dolphin House,
New Street,
Salisbury,
Wiltshire SP1 2TB
Tel: 01722 435478

The Society of Motor Manufacturers and Traders Limited (SMMT)

Forbes House,
Halkin Street,
London SW1X 7DS
Tel: 020 7235 7000
www.smmt.co.uk

Swift Group Limited, Dunswell Road, Cottingham, East Yorkshire HU16 4JX.
Tel: (01482) 875740 e-mail: enquiry@swiftleisure.co.uk web site: www.swiftleisure.co.uk

- A** After Sales Support114
 Arrival at Site19
 Awnings/Tents20
 Awning (side Fiamma F45i)105
- B** Battery36
 Bed Safety96
 Before Moving Off6
 Blinds97
 Butterfly Outlets59
- C** Cab screens103
 Caravan Clubs115
 CD tuner106
 Children16
 Codes of Conduct2
 Camp Sites2
 Coastal Code4
 Country Code4
 Connecting Services21
 Consumption Figures34
 Corner Steadies20
- D** DIY108
 Dometic Extractor Fan88
 Dometic Refrigerators68
 DVD/AV socket106
- E** Electrical Systems35
 Battery36
 Control Panel44
 Generator Guidelines50
 Mains Unit37
 Power Control49
 Power System (12V)38
 Solar Panel Connection37
 Technical Data & Approvals48
 Transformer/Charger38
 EC200 Electronic Control System39
 Electricity30
 En Route13
 Environmental Care111
 Escape Paths16
 Equipment Details51
 Equipment Power Consumption33
 Extractor Fan88
- F** Fire16
- G** Gas26
 Butane Gas26
 Propane Gas26
 Regulators26
 Gas Safety27
 Generator Guidelines50
 Grill85
- H** Heating55
 Hob85
 Hotplates85
- L** Large Storage Areas8
 Levelling the Vehicle20
 Loading the Vehicle7
- M** Mains Electrical Equipment Consumption33
 Mains Inlet Cable32
 Mains Socket/Water Connection22
 Mains Unit37
 Motorhome Care107
 Chassis/Rear Axle110
 Exhaust System110
 Exterior108
 Interior109
 Modifications108
 Winterisation/Storage110
 Motorhome Code1
 Motoring Organisations115
 Motorhome Terms6
- O** Omnistep Double Step102
 Omnistep Slide-Out100
 Oven86
 Overseas Connections31
 Owners Club114
- P** Passenger Seats8
 Positioning the Motorhome20
 Power System (12V)38
 Preparing for the Road5
- R** Reading Lamp (12V)100
 Refrigerators68
 Repair Facilities114
- Reversing camera monitor106
 Rooflights98
 Roof Loading8
- S** Safety & Security15
 Satellite navigation106
 Seat Belts9
 Security16
 Security Chips17
 Shower100
 Side Locker96
 Solar Panel Connection37
 Space Heaters55
 Spares114
 Spare Wheel Removal14
 Stoves Hobs, Grills and Ovens84
 Swivel Seats96
- T** Table96
 Thermal Insulation and Heating29
 Theftford Porta Potti92
 Three Point Seat Belts9
 Toilets92
 Towing Advice10
 Trade Association115
 Transformer/Charger Unit38
 Truma S3002 Space Heater55
 Truma Ultraheat57
 Truma Ultrastore Water Heater52
 Trumatic C600260
 TV aerials104
 Tyres8
- U** Useful Information113
- V** Vehicle Classifications10
 Ventilation16
- W** Water Heater52
 Water System22
 Windows98
 Winterisation/Storage110
 Wiring diagrams32