

Water system .....	36
Pressure switch .....	39
Water level sensor and cleaning .....	41
Typical gas schematic drawing.....	44
Gas.....	44
Types of gas.....	45
Gas safety advice .....	45
Thermal insulation and heating.....	49
Electricity .....	49
Mains connecting cable .....	50
Overseas connection .....	51
230v mains electrical equipment power consumption .....	51
Typical appliance consumption figures.....	52

## WATER SYSTEM

**WATER SYSTEM-  
INTRODUCTION**

All Swift Group motorhome water systems have been designed around a pump fitted within the motorhome. This pump draws water from an under floor or internal water tank, to provide water pressure within the water system, whenever it is switched on and water is available.

The schematic below shows the basic configuration of the water system:

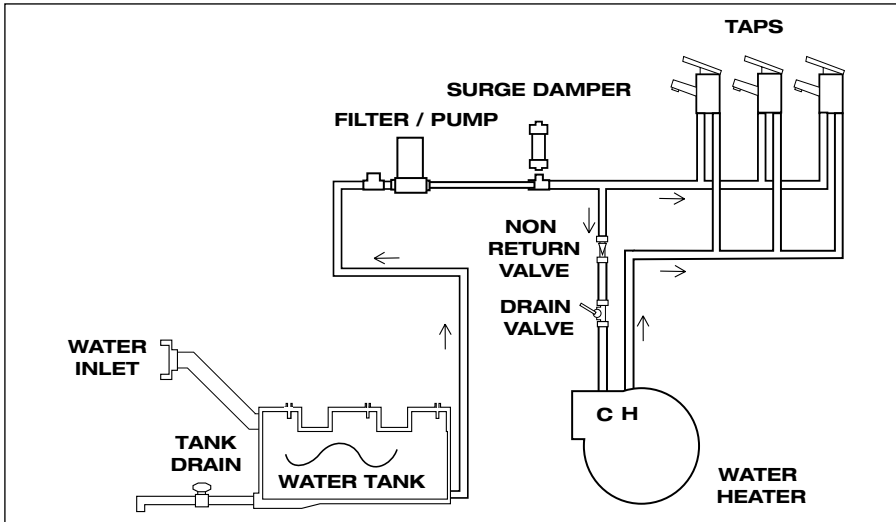

When power is supplied to the pump, it will draw water from the water tank, and pump it to the motorhome taps, shower and water heater.

The pump is fitted with its own pressure switch, and the pump will continue to pump water, until the pressure of water on the output of the pump reaches a pre-set level. For this pressure to be achieved, the taps must be closed.

When the taps are opened, water will leave the tap via the spout, and the pressure in the pipes between the pump and the taps will reduce. Because of this reduction in pressure, the pressure switch on the pump will switch back on and the pump will again run to pump more water.

Close to the pump, the water under pressure is split into two paths:

1. Through blue water pipes routed directly to the cold connection of each tap.
2. To the water heater.

Water from the pump enters the bottom of the water heater. Once the water fills the water heater (typically 10 litres), water then leaves the water heater via a connection at the top of that water heater. This water, which is still under pressure, then routes to the hot connection of each tap via the red pipes.

**To winterise the system please see separate details later in this handbook.**

**FRESH WATER SYSTEM**

- (i) All fittings, including the holding tank, water pipes, taps and connections are of food quality material (to BS6920) and therefore, should not affect the quality of the water used. It is recommended however, that the system is flushed through twice before it is used for the first time, and always cleaned/flushed after it has stood unused for a period of time (eg over the winter period). Care has been taken (using smooth bore pipes etc) to eliminate as many water traps as possible.
- (ii) When filling the fresh water system remember to check that the water source is suitable for use as drinking water and, if you are using a hose pipe or water carrier, that it is also made from nontoxic materials (preferably food quality material).
- (iii) The fresh water tank may be drained by the drain tap (blue) situated below the floor sill of the van.
- (iv) The fresh water system is pressurised by a pump which will continue to operate until it senses a pre-set pressure in the system.

**WARNING:** If the fresh water tank is completely empty the pump will be unable to pressurise the system and will operate continuously. In this situation it is essential that, in order to avoid damage to the pump, it is switched off using the pump isolator switch on the distribution panel until such time as the water tank has been filled.

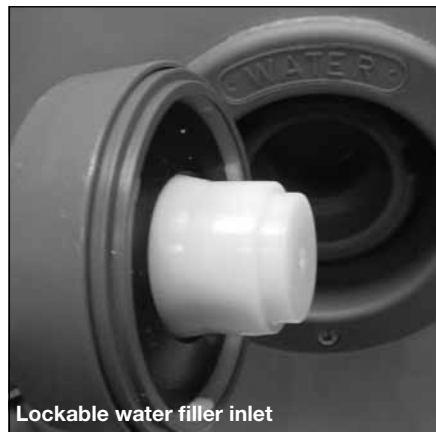

**Lockable water filler inlet**

**Fresh Water Tank**

Your motorhome is fitted with a water tank filled from the outside via a lockable water filler cap. When filling, use a hose manufactured from non toxic material, to prevent tainting of the water. Remember, if the water heater has been drained it will require 10 litre (0.2 gal) of water to fill it.

**WARNING:** If the water tank is over-filled, water will escape through the water filler and/or the breather fittings in the top of the water tank. If the tank is very full, further water may escape through tank breathers in transit.

## CLEANING WATER SYSTEM

Please ensure all taps are fully turned off when not in use.

We recommend the use of Milton 2 sterilising fluid for cleaning and sterilising the water tank and system.

An explanatory leaflet is available from:

The Milton Food Hygiene Advisory Service,  
Whitehall Lane Egham, Surrey, TW20 9NW

### CLEANING WATER SYSTEM

Clean the water system at the start and end of the season with sterilising fluid.

#### Sterilising

When cleaning the water system at the start or the end of the season it is advisable to use a sterilising fluid e.g. Milton 2, Chempro SDP or similar.

Flush the system thoroughly to remove the effective fluid traces.

When water is first introduced, or the water supply in the internal tank, runs out, air will be present in the pipework. It is important that every tap is run to remove any air in the system before, for instance, the shower is used. Air left in pipework local to a tap can act as an accumulator and affect the ratio of hot and cold water flowing from other taps or shower mixers in the system.

#### System care

Allowing water to freeze in the system may result in damage to the pump and plumbing system.

Non-Toxic antifreeze for potable water may be used with Truma pumps. Follow manufacturers recommendations.

Do not use automotive antifreeze to winterize potable water systems.

These solutions are highly toxic and may cause serious injury or death if ingested.

#### Sanitising

The water systems, and in particular storage tanks, in motorhomes are susceptible to contamination by bacteria if care is not taken with their use and cleaning. The symptoms

caused by bacterial contamination are not purely limited to gastro-intestinal diseases, but may also manifest themselves as ear, nose, throat, eye or skin infections. It is therefore important that you carry out the following procedure prior to using the motorhome each time, even if you boil or filter all water you use for drinking.

#### Separate Water Containers

1. All water remaining in the container should be disposed of so that the container is empty.
2. The outside of the container should be thoroughly cleansed and washed down to remove any dirt, dust or other contaminant. Water at a suitably hot temperature containing an appropriate detergent is recommended for this purpose.
3. Water should be put in the container, swirled around, then emptied out.
4. The container should then be totally filled with water containing an appropriate sterilant solution and allowed to stand for the recommended contact time (e.g. Milton for 15 minutes).
5. The solution should be emptied from the container.
6. The opening of the container should be cleaned thoroughly with an appropriate prepared wipe impregnated with a sterilant.
7. The container should be inverted whilst stored overnight (if possible).
8. The container must be filled with mains water only and mains water only should be used for the above cleaning procedure.
9. On no account should garden hoses be used to fill water tanks.

#### For Systems:

1. Drain down the system (open all taps to allow air in, enabling the system to drain quickly).
2. Remove any water filters fitted, and replace with a short length of hose or

empty filter cartridge (this will ensure the filter is not affected by the disinfectant/sterilant solution).

3. Fill the water system with a disinfectant/sterilant solution (check that the solution at full strength appears at all taps/showers). Allow to stand for the recommended period of time.
4. Drain the system completely.
5. Thoroughly clean the outside of all taps/connectors with a cloth soaked in the disinfectant/sterilant.
6. Flush the system through with clean drinking water until no traces of disinfectant/sterilant can be detected at any tap.

Suitable sterilising chemicals are available from your motorhome dealer, accessory shop, chemist or home-brew shops. It is not, however, recommended to use bleach or sodium metabisulphite.

### Waste water system

- (i) The waste water holding tank is secured underneath the chassis of your motorhome and is gravity fed.
- (ii) In order to eliminate unpleasant odours as much as possible, only smooth bore pipes are used.

However, should the waste water tank be overfilled, then the waste water will backfill the drain pipes until it eventually appears in the shower base. In order to prevent this, please take note of part (iii).

- (iii) The waste water gauge shows the level of the tank in half increments, it is therefore, recommended that the waste water tank is checked on a daily basis, emptying when required. This is done by opening the valve located just beneath the side skirt on the exterior of the Motorhome.
- (iv) The waste tank may be drained by the drain tap (grey) situated below the floor sill of the van.

It should be emptied either directly, or via a waste water container (not supplied) into a designated waste water area.

## PRESSURE SWITCH

The purpose of a pressure switch is to monitor the pressure on the outlet side of the pump. When a tap is closed, and the pump continues to run, there is an increase of pressure in the system, and when that pressure reaches a pre-set limit, the pressure switch will turn the pump off.

### PRESSURE SWITCH ADJUSTMENT

Pressure Switch Adjustment, Truma/Flo-Jet pump. (Normally Grey upper section with White lower section/valve housing)

- All of the Truma/Flo-Jet pumps used by Swift are pre-set at 25psi + / -3psi.
- To further adjust the pressure switch setting, a cover cap must be first be removed from the end of the pump to reveal a pressure adjusting screw, as shown in the photos. A maximum of 1/4 turn clockwise or anti-clockwise, from the factory setting, is advised. Turning the screw clockwise 1/4 turn will increase the pressure switch cut-out pressure, turning the screw anti-clockwise will reduce the pressure setting.
- Please note a second screw mounted below the cover cap is set in position with threadlock, this should not be disturbed.

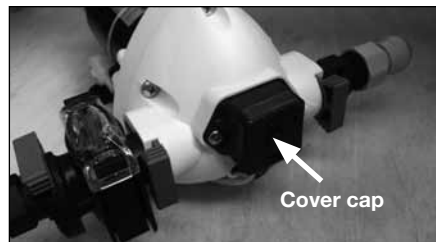

## WATER SYSTEM TROUBLE SHOOTING

The pump may have to be removed to gain access to the adjusting screw. Drain the water system before removing the pump.

To remove the pump pull the blue taps at right angles to the pipe work and lift the pump out.

### TROUBLE SHOOTING

#### **Pump will not start, when the tap is opened:**

- Check fuse(s).
- Check power source(s), and ensure there is sufficient voltage to run the pump.
- Ensure 'pump' LED is illuminated.
- Using a multi-meter, ensure there is power at the pump. If not, refer to your dealer as there maybe damaged cabling or a fault with the fusebox.
- Is the pump hot? If so, allow to cool before retrying.
- Has the vehicle been stored over winter? was it correctly winterised? If no, the pump may have frozen, causing permanent damage.
- The pressure switch may need adjusting. (See pressure switch paragraph in this section for how to do this)

#### **Pump runs, but will not pressurise system (i.e. no or little water being discharged from taps) - Not Pulsing:**

- Ensure that there is water in the fresh water tank.
- Check in-line filter is free from debris and correctly fitted.
- Ensure water system has been primed correctly, (see priming the water system page 44), and there are no air-locks present.
- Ensure there are no restrictions in the plumbing.
- Using a multi-meter, ensure there is power at the pump. If not, refer to your dealer as there maybe damaged cabling or a fault with the fusebox.

- Ensure the inlet side of the pump is watertight and not allowing air into the system.
- Using a multimeter check that the voltage is between 10 and 14.5 volts. If not, refer to your dealer.

#### **Pump continues to run (for more than 5 seconds) after taps are closed or pump turns on for no reason:**

- Check for leaks on the high pressure side of the pump.
- Ensure water system has been primed correctly, as per the handbook, and there are no air-locks present.
- Ensure the pump is securely mounted.
- Ensure the piping on the high pressure side of the pump is in good condition (not blowing or deforming).
- The pressure switch may need adjusting. (See pressure switch paragraph in this section for how to do this)

#### **Noisy or rough operation**

- Check for leaks on the high pressure and low pressure side of the pump.
- Ensure that all pipes (especially those within 150mm of the pump) are not touching any furniture.
- Ensure the pump is securely mounted

#### **Pump rapidly cycles (switches on or off) or water pulses from taps, including temperature pulsing:**

- Check for leaks on the high pressure and low pressure side of the pump.
- Ensure there are no restrictions in the plumbing
- The pressure switch may need adjusting. (See pressure switch paragraph in this section for how to do this)

## WATER LEVEL SENSOR & CLEANING

### Principle

The sensor, fitted to Swift Group motorhomes are pre-fitted to water tanks, and link to the control unit, via a pre-fitted wiring harness.

Two types of level sensor are used:

1. A series of float switches fitted through the side of the tank at different levels which provide a reading at the control unit.
2. A series of stainless steel studs in the side of the tank, the conductivity of the water between the studs providing a reading at the control unit.

The sensors are 'digital', in that while the conductivity (resistance) value can vary, the fusebox will register any conductivity between the reference stud and the other studs, indicating water present.

Normally, even if the studs are dirty, and providing the studs have not been bridged by a foreign object, a circuit will still be delivered back to the control unit and a water level displayed. Similarly the float switches are either open or closed indicating water whether water is present or not.

### Stud Sensor cleaning

The first step, in case of fault diagnosis, is to clean the sensor studs. False water level readings at the control unit can be caused by calcium build-up or foreign objects within the tank bridging the studs. (Especially with waste tanks).

**WARNING:** Only use food safe plastic mesh scourers, which are suitable for domestic use, for cleaning the sensor studs.

1. Remove the studs from the tank
2. Check the studs for build up of contamination
3. Use clean soapy water
4. Place scourer in water to dampen
5. Apply scourer to the sensor studs with limited pressure

6. Rub sensor studs removing contamination
7. Swill sensor studs with fresh clean water
8. Replace sensor stud into tank, ensure they are sealed.

### PRESSURE SWITCH ADJUSTMENT

Pressure Switch Adjustment, Truma/Flo-Jet pump. (Normally Grey upper section with White lower section/valve housing)

- All of the Truma/Flo-Jet pumps used by Swift are pre-set at 25psi + / -3psi.
- To further adjust the pressure switch setting, a cover cap must be first be removed from the end of the pump to reveal a pressure adjusting screw, as shown in the photos. A maximum of 1/4 turn clockwise or anti-clockwise, from the factory setting, is advised. Turning the screw clockwise 1/4 turn will increase the pressure switch cut-out pressure, turning the screw anti-clockwise will reduce the pressure setting.
- Please note a second screw mounted below the cover cap is set in position with threadlock, this should not be disturbed.

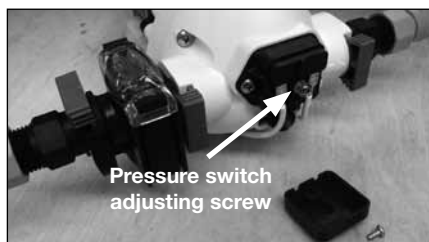
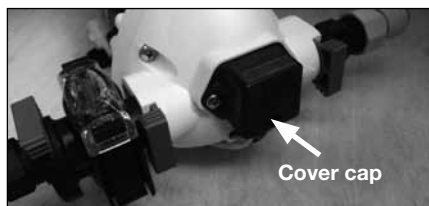

The pump may have to be removed to gain access to the adjusting screw. Drain the water system before removing the pump.

To remove the pump pull the blue taps at right angles to the pipe work and lift the pump out.

## WATER SYSTEM FAULT FINDING

### WATER

Fault	Cause	Remedy
Water not flowing from any tap when operated but pump runs	Freshwater tank empty Pump wired in reverse Pipe inlet or outlet pipe disconnected Pump pipes restricted by kinking Blockage in pump inlet or outlet pipe Blocked pump filter Air leak in suction line to pump	Check Check wiring, refer to pump manufacturers instructions Check connections Check pipes run Check, starting inside freshwater tank Dismantle and clean filter. See pump manufactures instructions. Check condition of pipe and pipe joints between the water tank and the pump.
Pump does not run	Pump incorrectly wired Pump fuse blown Battery disconnected Pump seized or overheated Pressure pump sensing switch may have failed Contacts may be faulty Wiring connections may be faulty	Refer to pump manufacturers instructions Check wiring connection and then replace with fuse of correct rating Check connections Refer to pump manufacturers servicing instructions Refer to pump manufacturers servicing instructions Check contacts in plug and socket are clean and making contact Check wiring connections
Water flows from cold tap but not from hot	Blockage in hot pipeline Heater inlet or outlet pipes kinked preventing flow Hot tap failed or blocked Heater non-return valve jammed	Disconnect pipes and inspect Check and re-route if necessary. Disconnect and inspect Seek service attention

**WATER**

<b>Fault</b>	<b>Cause</b>	<b>Remedy</b>
Water flows from hot tap but has reduced flow from cold	Cold water pipe kinked preventing flow	Check and re-route if necessary
	Blockage in cold pipe line	Disconnect pipes after 1st connector and check up to tap
	Cold tap not connected	Refer to installation instructions
	Cold tap failed or blocked	Disconnect and inspect
Reduced flow from both hot and cold taps	Battery condition low causing pump to run slowly	Check battery state of charge, refer to electrical supply note
	If new taps have been fitted they may be restricting flow	Disconnect and check that they have at least 1/4" (6.3mm) bore
	Pump needs servicing	Refer to pump servicing instructions
	Partially blocked pump filter or in-line filter, if fitted	Dismantle and clean if necessary
	Pump outlet pipe kinked restricting flow	Check and re-route if necessary
	Water leak	Check all water connections
Reduced flow from either tap	Pipe kinking restricting flow	Check and re-route if necessary
	Bore size difference in taps	Use taps of equal bore size
If pump motor runs steadily and will not stop	Battery voltage may be too low (below 10.5 volts)	Check that there is water in the container Adjust switch and/or re-charge battery Check all connections in pipework

## GAS

## TYPICAL GAS SCHEMATIC DRAWING

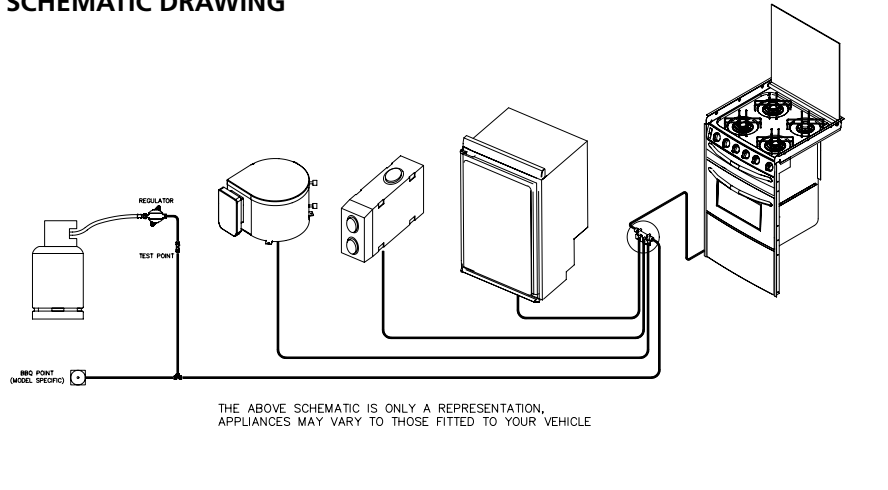

### Gas

#### GENERAL INFORMATION

##### Gas Bottles

Bottled Liquefied Petroleum Gas (LPG) is the most convenient portable source of fuel for your vehicle.

Regularly check flexible gas hose, joints and connections for tightness. Finally make sure that each gas appliance is working efficiently to the recommendations of the appliance manufacturers.

Only use gas bottle cylinders that are located within their dedicated position within the gas bottle housing, never extend hose - hose lengths must not exceed 400mm.

##### Regulator

Your vehicle is supplied with a wall mounted gas regulator plumbed inside the gas bottle compartment. The regulator and all appliances work at a harmonised 30mb pressure, which work with Butane and Propane gas.

Pressure regulation system in this vehicle has a fixed working pressure of 30 mbar with a flow rate of either 1.2 kg/H or 1.5kg/H and complies with the requirements of EN 12864 annex D.

We do not recommend the use of an inline LPG BBQ with the 1.2kg/H regulator when other LPG appliances are in use.



**Standard regulator**

##### Gas Hoses

High-pressure hoses or pigtails as they are called must be used with the new style regulator.

LPG bottle i.e. Propane, Butane, BP and Camping Gaz cylinders all have unique bottle adaptor connections. It is important to check you have the correct hose and adaptor to suit your gas bottles.

Push on hoses are no longer permitted under the latest regulations.

The new high-pressure hoses have threaded connections and must be securely attached to the regulator and to the gas bottle.

Ensure that there is a constant rise in the flexible gas hose between the gas bottle outlet and the regulator elbow.

**WARNING: Inspect flexible gas hose(s) regularly for deterioration and renew as necessary with the approved type, in any case no later than 5 years after the date of manufacture marked on the hose.**

**WARNING: Ensure hoses do not become entangled in door mechanism.**

## TYPES OF GAS

### Butane

Butane is supplied in the UK in green, blue or aluminium bottles.

All these have a male left hand thread EXCEPT for Camping Gaz which has a special female right hand thread and Calor 7kg and 15kg and aluminium bottles which have a special clip-on connection. Continental bottles usually have a male left hand thread similar to but not identical with UK butane.

Butane is suitable for use at temperatures down to 2°C but will not work below that.

### Propane

Propane is supplied in red, or partly red bottles which have a female left hand threaded connector. Scandinavian countries use the same connector. Germany and Austria supply propane with a male connection.

Propane will work at temperatures as low as -40°C and is therefore suitable for all winter caravanning.

## GAS SAFETY ADVICE

**WARNING: If you smell gas or suspect a leak and if it is safe to do so, isolate the gas appliances and turn off the gas bottles at the regulator. Evacuate the vehicle and ventilate. Seek professional advice as to the cause of the leak.**

### Facts about LPG

LPG is not poisonous.

Bi-products are harmless.

There is danger if all air and oxygen were excluded. (Ventilation holes must be kept clear at all times).

LPG has been given a smell by the manufacturers in order to identify leaks.

### Awning Spaces LPG Appliance Exhaust

There is no danger of pollution of an enclosed awning space by the LPG exhaust from a refrigerator venting into it, as awning spaces are generally well ventilated.

Space heaters may produce sufficient exhaust to pollute the awning space, if it is totally enclosed, from a general comfort, smell and hygiene point of view. In the extreme case there could be a build up of carbon dioxide to a dangerous level.

Owners are advised to allow some fresh air circulation in the awning space when such appliances are in use.

### PRECAUTIONS

- a) Never look for a leak with a match. Always use a soap solution or its equivalent when testing connections. Do not operate any electrical apparatus whatsoever, especially light switches. If the leak is not obvious, the vehicle should be evacuated and qualified personnel consulted.
- b) Always turn off the gas cylinder valve or inlet to the vehicle when the appliances are not in use.
- c) Never use gas appliances without adequate ventilation.
- d) Avoid naked lights when connecting or changing a cylinder.
- e) Check the flexible hose frequently.
- f) The gas is heavier than air and therefore sinks to the lowest point.
- g) Keep bottle gas containers outside (and protected against frost). If they must be kept inside make sure they are well away from heat.

## GAS

- h) Always seek advice when in doubt.

**WARNING: Do not use appliances with a different working pressure to 30mbar.**

**WARNING: Maintain adequate spacing of combustible materials from sources of heat.**

**WARNING: Do not use independent portable gas appliances inside the vehicle.**

**WARNING: Always read individual appliance instructions.**

### Ventilation

**WARNING: Safety ventilation shall in no circumstances be obstructed even partially, screens and grills must be kept clean and free from dust**

All ventilation complies with BSEN 721 and vents should not be obstructed in any manner as this could lead to insufficient fresh air. In this case the confined atmosphere becomes depleted of oxygen which leads to the formation of the highly poisonous gas 'carbon monoxide'. Carbon monoxide is odourless, colourless and tasteless and will rapidly cause unconsciousness and death with little or no warning prior to collapse. THERE IS NO DANGER WHEN ADEQUATE VENTILATION IS PROVIDED.

### Changing gas cylinders

The following procedure should be adopted:

- Extinguish any fire, flame or source of ignition (including cigarettes, pipes and pilot lights) before changing gas cylinders.
- Wherever possible change gas cylinders in the open air.
- Ensure that the gas cylinder valve(s) is/are closed before disconnecting any empty cylinder or before removing the plastic cap or plug on the outlet connection of the replacement cylinder. (Note. left hand thread.)

- Make firm gas-tight joints. Any leaking vapour will smell. If a leak is suspected after changing gas cylinders and opening valve, test by brushing with soapy water around the joints. Bubbles will form if vapour is leaking. Never use a naked flame.
- Ensure that the replacement gas cylinder is the correct one for the installation.
- Gas cylinder valves are of various designs depending on the type of cylinder and the use for which it is intended and it is essential that the correct pressure regulator with the correct pressure setting and capacity for the installation is used in accordance with manufacturer's instructions.
- In the case of a connection on the pressure regulator which relies upon a sealing washer(s) to maintain a gas-tight joint, it is essential to check that the washer is present, is sound and is correctly positioned prior to making the connection. Where the connection relies on a metal to metal seating or bull nose connection to obtain a gas-tight joint it is essential that the mating surfaces are clean and undamaged. In no case should a damaged valve or connection be used.
- Where connections are designed to be tightened with a spanner, it is essential that a spanner of the correct size is used and that the union is firmly tightened, hand tightness is not sufficient. When self-sealing valves are incorporated in a gas cylinder, connections should be made in accordance with the manufacturer's instructions and tools should not be used.

### Leaks

Action to be taken in the event of a suspected leak:

- If a gas leak is suspected, close the gas cylinder valve or other valve at the inlet to the vehicle. Do not operate electrical switches. Open all doors and windows to disperse any gas escape.

- b) The strong unpleasant smell of LPG will enable the general area of the leak to be detected. Check that gas is not escaping from an unlit appliance. In the case of a leak, close cylinder valve(s) and call a competent installer to rectify the fault.
- c) If a leaking gas cylinder cannot be stopped, remove the cylinder to a safe place in the open air in an upright position away from drains and any source of ignition.

### Fire

Precautions and actions to be taken:

- a) A fire extinguisher of adequate size and preferably of the dry powder type should be available.
- b) The initial use of dry powder extinguishers is recommended only if it is likely that the leakage can be stopped by closing the cylinder valve or that the cylinder can be speedily removed.
- c) Cool with water all gas cylinders that cannot be removed.
- d) As soon as possible remove cylinders adjacent to the fire to a safe place in order to gain access to the seat of the fire.

### Connection

Ensure that the gas regulator hose is correctly connected to the gas cylinder in the gas bottle compartment and that the hose connection is tight.

Gas bottles must be fully located, seated at the base of the bottles and restrained by the strap provided in the dedicated compartment position. Straps are positioned to suit 6kg, 7 kg and 13kg bottles.

**WARNING: If using cylinders other than those recommended, the user must ensure these are adequately supported, ventilation openings must not be obstructed and the cylinders must not cause damage to other fixtures and fittings located in the compartment.**

Open ended gas hoses must always be protected from dirt and insects.

Before turning on the gas supply at the regulator, ensure that all gas operated equipment in the vehicle is turned off.

All gas equipment is supplied through a central Gas Manifold System which has individual isolation taps for each appliance (Fig. A).

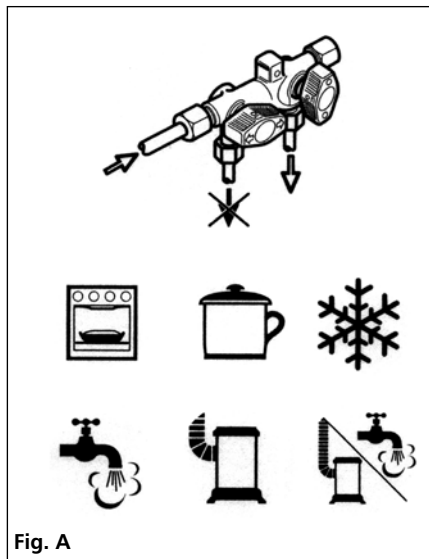

Fig. A

**NOTE:** If the motorhome is in storage or not being used for a period of time, we recommend turning off the gas supply at the gas bottles.

## GAS FAULT FINDING

**GAS**

<b>Fault</b>	<b>Cause</b>	<b>Remedy</b>
Hob does not light	No gas  Air in pipe	Check level of gas in bottle Check gas bottle valve is on Check gas taps are on  Purge system Refer to hob manufacturers instructions
Oven does not light	No gas  Air in pipe	Check level of gas in bottle Check gas bottle valve is on Check gas taps are on  Purge system Refer to oven manufacturers instructions
Space heater	No gas  Over gassed Air in pipe	Check level of gas in bottle Check gas bottle valve is on Check gas taps are on Check exhaust outlet is clear  Turn off appliance, wait 2 minutes and try again Purge system Refer to space heater or boiler manufacturers instructions
Fridge does not light	No gas  Air in pipe	Check level of gas in bottle Check gas bottle valve is on Check gas taps are on  Purge system Refer to fridge manufacturers instructions
Water heater does not light	No gas  Air in pipe	Check level of gas in bottle Check gas bottle valve is on Check gas taps are on  Purge system Refer to water heater manufacturers instructions

## THERMAL INSULATION AND HEATING

Your vehicle has been designed to achieve a thermal insulation and heating level for specific climatic conditions when tested according to the procedure in EN1646-1. The classifications are as follows:

### GRADE 1

A vehicle with an average thermal transmittance ( $u$ ) that does not exceed  $1.7w/(m^2k)$ .

### GRADE 2

A vehicle with an average thermal transmittance ( $u$ ) that does not exceed  $1.7w/(m^2k)$  and which can achieve an average temperature difference of at least 20k between inside and outside temperatures when the outside temperature is  $0^{\circ}C$ .

### GRADE 3

A vehicle with an average thermal transmittance ( $u$ ) that does not exceed  $1.2w/(m^2k)$  and which can achieve an average temperature difference of at least 35k between inside and outside temperatures when the outside temperature is  $-15^{\circ}C$ .

## THE ELECTRICAL SYSTEM

### General Information

It is strongly advised that the mains installation is inspected periodically to ensure safe use. The IET (BS7671) wiring regulations recommend that mains installations in motorhomes are re-inspected every 3 years or annually if the van is used frequently. The National Caravan Council lists the qualifications necessary to perform this inspection, but an NICEIC approved contractor is probably the first choice.

### On arrival at the campsite

- Check the suitability of the supply, is it AC or DC, is the voltage and frequency correct.
- Ensure that there is a proper earth (3 pin socket outlet).
- If in doubt consult site staff.

- Make sure that the supply from the site is switched off.
- Make sure that the charger switch on the PSU is switched off.
- Lift the cover on the electricity inlet on the motorhome, and insert the connector on the flexible supply cable.
- At the site supply point, connect the other end of the supply cable to this using the socket provided.
- Switch on the main switch at the site supply point.

**CARE POINT:** It is good practice to test the RCD (Residual Current Device) in the PSU before switching on. There is a test button on the RCD to test the lever, put the lever in the up position (on) before testing.

**CARE POINT:** As with the RCD it is good practice to check the Miniature Circuit Breaker (MCB) in the PSU. Switch all to the on position (lever up). If any do not stay up then there is a fault.

On departure from the campsite

- Switch off supply from the site, disconnect the cable at both ends.
- Switch off RCD.

**Note:** never use a mains supply lead whilst coiled. Always uncoil the full length before connecting to the supply and remember to protect the cable from traffic.

**WARNING:** current consumption in the motorhome must not exceed 16 amps or the pitch permitted maximum if this is less than 16 amps.

WIRING OF MAINS CONNECTING CABLE

WIRING OF CONNECTING CABLE AND MOTORHOME MAINS INLET

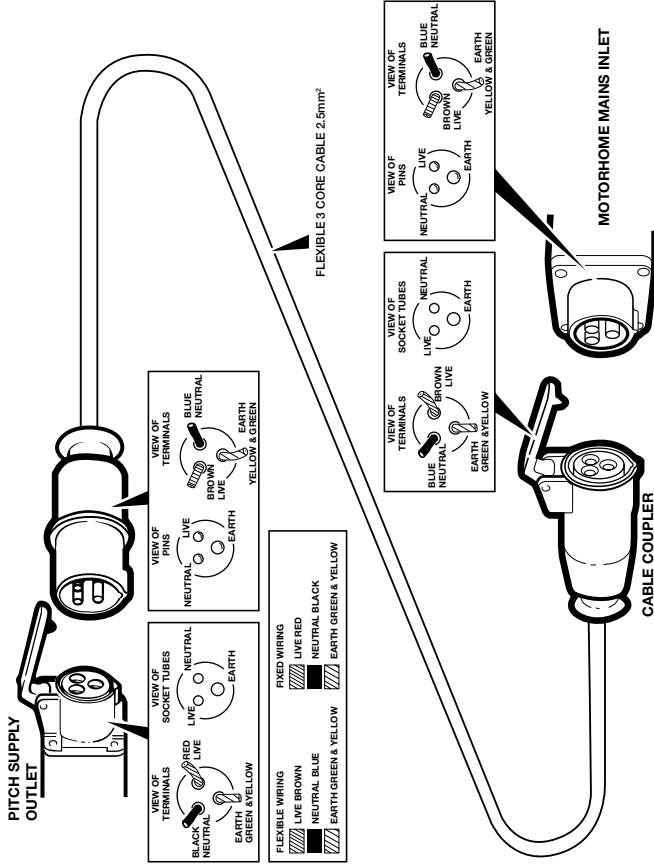

The legal length of the mains inlet cable is 25 ± 2 metres. When in use it must be fully uncoiled and protected from traffic.

## OVERSEAS CONNECTION

- Connection to a mains voltage overseas requires particular attention.
- Overseas supplies can be of reverse polarity.
- Reverse polarity results in equipment not necessarily being isolated when turned off, reverse polarity indicator on the PSU will light in the event of reverse polarity.
- The only sure way to make equipment safe is to unplug it.
- It is useful to have a means of checking polarity when overseas.
- If it can be achieved then connect live to live, and neutral to neutral to achieve full electrical protection.

**WARNING:** Never allow modifications of electrical or LPG systems and appliances except by qualified persons.

## 230V MAINS ELECTRICAL EQUIPMENT POWER CONSUMPTION

### Please note:

It is possible that the 230V mains electrical equipment may not all operate simultaneously. A typical UK motorhome site mains hook up point provides a maximum output of 10 amps and on some continental sites the available output may be as low as 5 amps.

If your loading exceeds the site supply it may trip the site circuit breaker. Please check the available mains output with your site operator.

Similarly loadings on each circuit breaker within the vehicle should be observed

A label positioned close to the MCB's will identify which appliances within the vehicle are fed from which MCB. Consulting the table (Typical Appliance Consumption Figures) in conjunction with this label, will give an indication of which appliances can, and cannot, (site supply allowing), be operated simultaneously.

## POWER CONSUMPTION

## TYPICAL APPLIANCE CONSUMPTION FIGURES

Appliances	230V		12V		LP GAS Grams/hour
	Watts	Amperes	Watts	Amperes	
Theftford N80	140 / 200W	0.6Amp / 0.9Amp	Only when driving		14 / 21 g/h
Dometic RM7271 fridge	135w	0.6a	Only when driving		11g/h
Waeco CR80 fridge	25w	0.108a	24w	2a	Not applicable
Truma Ultrastore water heater	850w	3.7a	Not applicable		120g/h
Truma Combi 4 heater/boiler	2000w	8.5a	67w	Max 5.6a	160 - 320g/h
Truma E2400 heater	Not applicable		7 – 13w	0.6 - 1.1a	100 - 200g/h
Spinflo Triplex	Not applicable		Not applicable		112g/h
Hotplate 1	Not applicable		Not applicable		112g/h
Hotplate 2	Not applicable		Not applicable		180g/h
Hotplate 3	Not applicable		Not applicable		115g/h
Grill	Not applicable		Not applicable		112g/h
Oven	Not applicable		Not applicable		196 – 320g/h
SMEV hotplate	Not applicable		Not applicable		95g/h
SMEV oven/ grill	Not applicable		Not applicable		Not applicable
Battery charger 25a	500w	Max 3.6a	Not applicable		Not applicable
Water pump	Not applicable		48w	4a	Not applicable

Note: These are approximate figures for guidance only.