



Escape Motorhomes, Dunswell Road,
Cottingham, East Yorkshire HU16 4JX.

Tel: 01482 875740 Fax: 01482 840082

email: enquiry@swiftgroup.co.uk

website: www.britisheescape.co.uk

A MEMBER OF THE SWIFT GROUP

1086678 Issued February 2009



Specification, wiring diagrams and bulb chart



CONTENTS

Specifications	2
Capacities	3
Jacking	4
Wiring Diagrams	5
Bulb Chart	11
Bulb Replacement.....	12

Specifications

Model	Escape 622	Escape 624	Escape 664	Escape 686 Standard	Escape 686 Optional
Engine	Fiat '100 MultiJet' diesel	Fiat '100 MultiJet' diesel	Fiat '100 MultiJet' diesel	Fiat '100 MultiJet' diesel	Fiat '130 MultiJet' diesel
Engine Capacity	2198cc	2198cc	2198cc	2198cc	2287cc
Engine Power	100bhp @ 2900rpm	100bhp @ 2900rpm	100bhp @ 2900rpm	100bhp @ 2900rpm	130bhp @ 3600rpm
Torque	250Nm @ 1500rpm	250Nm @ 1500rpm	250Nm @ 1500rpm	250Nm @ 1500rpm	320Nm @ 2000rpm
Chassis	Fiat Chassis	Fiat Chassis	Fiat Chassis	Fiat Chassis	
Wheel base	3.45m/11'4"	3.45m/11'4"	3.80m/12'6"	4.04m/13'3"	
Designated Passenger Seats	1	3	3	5	
Berths (sleeping positions)	4	5	4	6	
Overall Length (no ladder)	6.30m/20'8"	6.30m/20'8"	6.72m/22'1"	6.92m/22'8"	
Overall Width (mirrors folded)	2.24m/7'4"	2.24m/7'4"	2.24m/7'4"	2.24m/7'4"	
Overall Height	2.94m/9'8"	2.94m/9'8"	2.85m/9'4"	2.94m/9'8"	
Maximum Technical Permissible Laden Mass (A)	3300kg	3300kg	3500kg	3500kg	
Mass in Running Order (B)†	2842kg	2884kg	2860kg	2963kg	2978kg
Maximum User Payload (A-B)	458kg	416kg	640kg	537kg	522kg
Essential Habitation Equipment	10kg	10kg	10kg	10kg	
Thermal Insulation Grade	Two	Two	Two	Two	
Bed Sizes					
Front Double		1.89m/6'2"/1.22m/4'0"	2.08m/6'10"/1.24/0.93m/4'1"/3'1"	1.84m/6'0"/1.22m/4'0"	
Front Nearside Single		1.85m/6'1"/0.68m/2'3"			
Front Offside Single		1.89m/6'2"/0.92m/3'0"		1.84m/6'0"/0.92m/3'0"	
Rear Double	2.08m/6'10"/1.76m/5'9"		1.87m/6'2"/1.27m/4'2"	2.08m/6'10"/1.34m/4'5"	
Rear Nearside Single	1.89m/6'2"/0.68m/2'3"				
Rear Offside Single	1.76m/5'9"/0.68m/2'3"				
Overcab Bed	2.08m/6'10"/1.37m/4'6"	2.08m/6'10"/1.37m/4'6"		2.08m/6'10"/1.37m/4'6"	

- NOTE:**
1. **The Maximum User Payload** includes:
 - a) the **conventional load** (this is the allowance for passengers)
 - b) **essential habitation equipment** (items and fluids required for safe and proper functioning of habitation equipment)
 - c) **optional equipment** (items available from the manufacturer over and above the standard specification)
 - d) **personal effects** (those items not covered by the above)
 2. The **Mass in Running Order** is the mass of the unladen vehicle including a 75kg allowance for the driver plus engine coolants and 90% of the fuel tank, water tank and gas capacity.
 3. PLEASE TAKE CARE TO ENSURE THAT YOU HAVE ALLOWED FOR THE MASSES OF ALL ITEMS YOU INTEND TO CARRY IN THE MOTOR CARAVAN, e.g. passengers, optional equipment, essential habitation equipment and personal effects, such as clothing, food, pets, bicycles, sailboards, sports equipment etc.
 4. **WARNING** - UNDER NO CIRCUMSTANCES SHOULD THE MAXIMUM TECHNICAL PERMISSIBLE LADEN MASS OF THIS MOTOR CARAVAN BE EXCEEDED.

Water Tank Capacities

	Fresh Water Tank	Waste Water Tank	Water Heater	Toilet Tank (Flushing)
Escape	65 litre	68 litre	10 litre	0 litre

Gas Capacities

	Capacity
Escape	2 x 7kg

The above are recommended gas bottle sizes

NOTICE

For technical data on the base vehicle please refer to manufacturer's handbook

ESCAPE

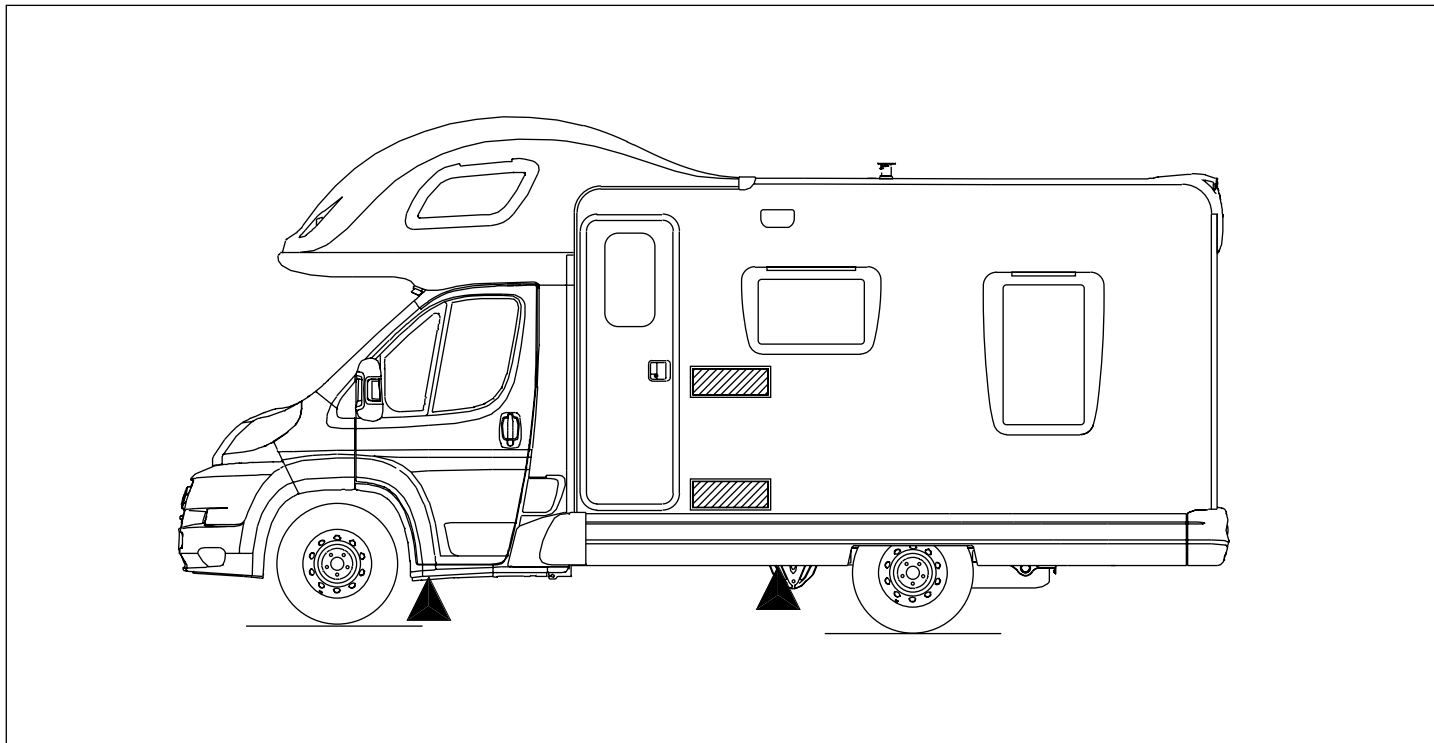

Jacking Points for High-Line and Low-Line: ▲

ROAD LIGHTING

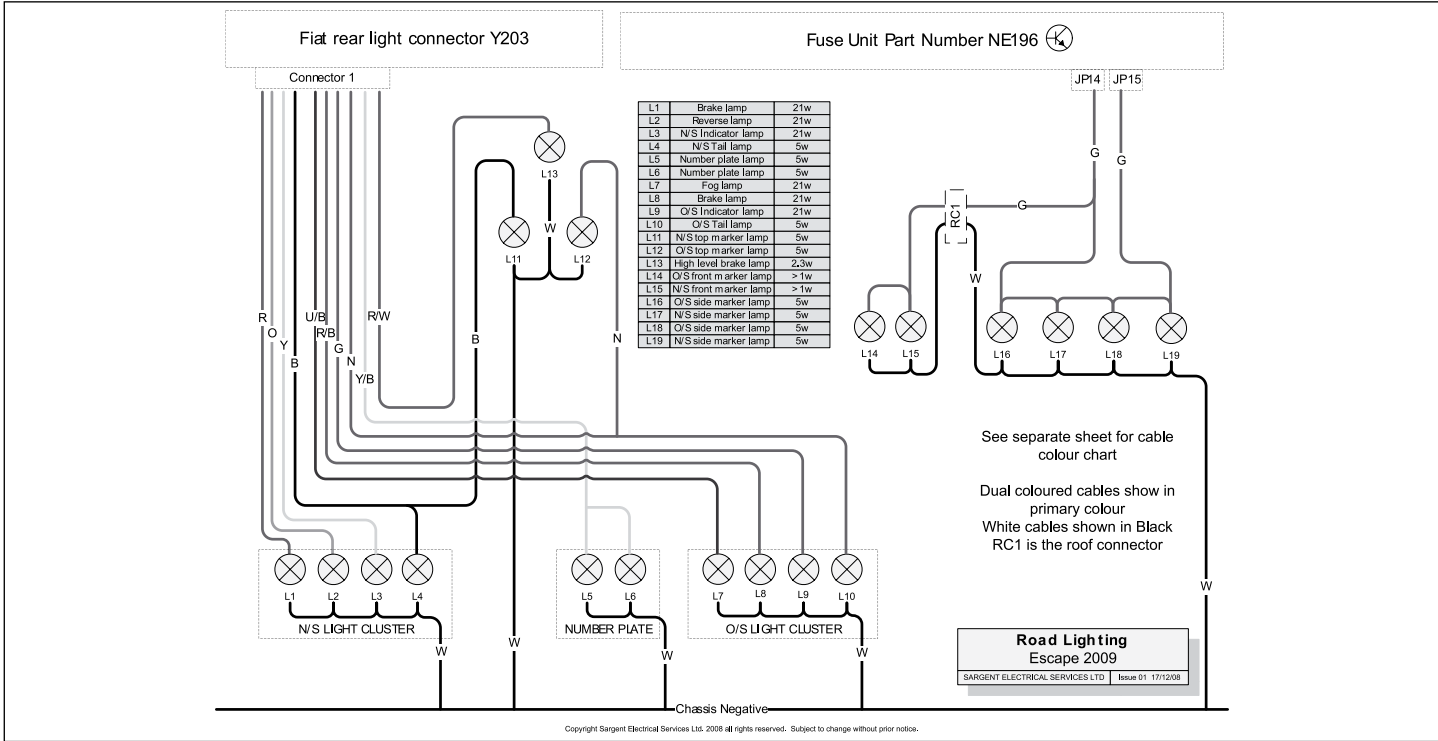

Copyright Sargent Electrical Services Ltd. 2008. All rights reserved. Subject to change without prior notice.

Wiring Diagrams

CONSUMER CIRCUITS – ROOF

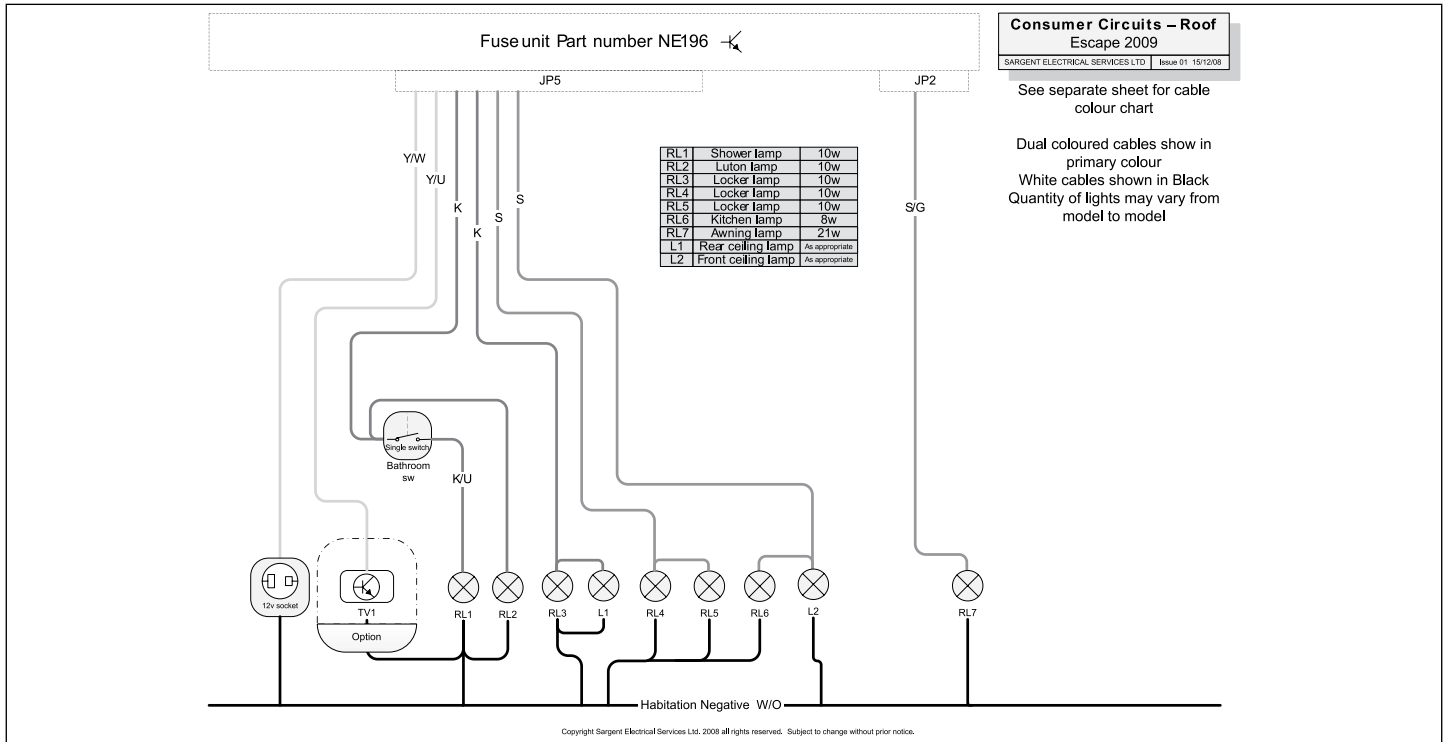

POWER CIRCUITS

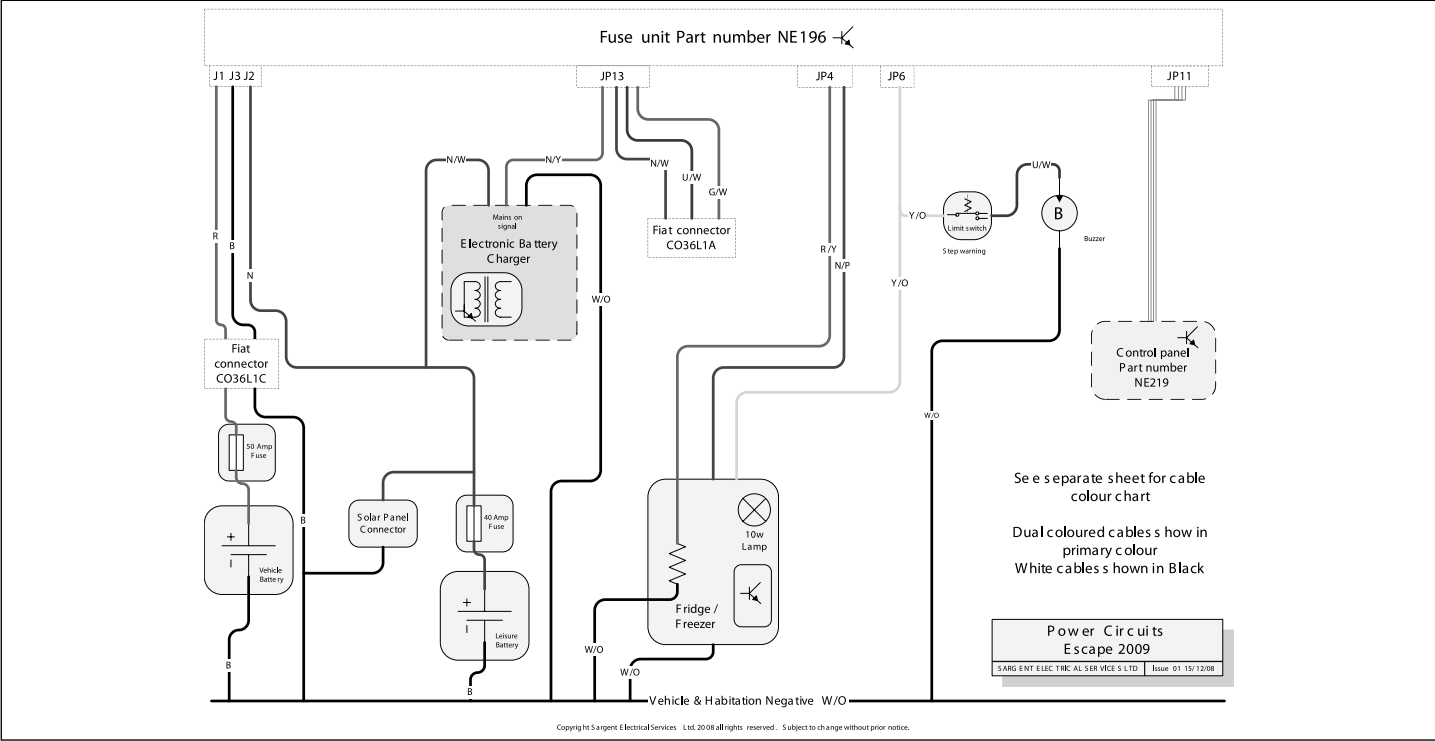

Wiring Diagrams

CONSUMER CIRCUITS – FLOOR

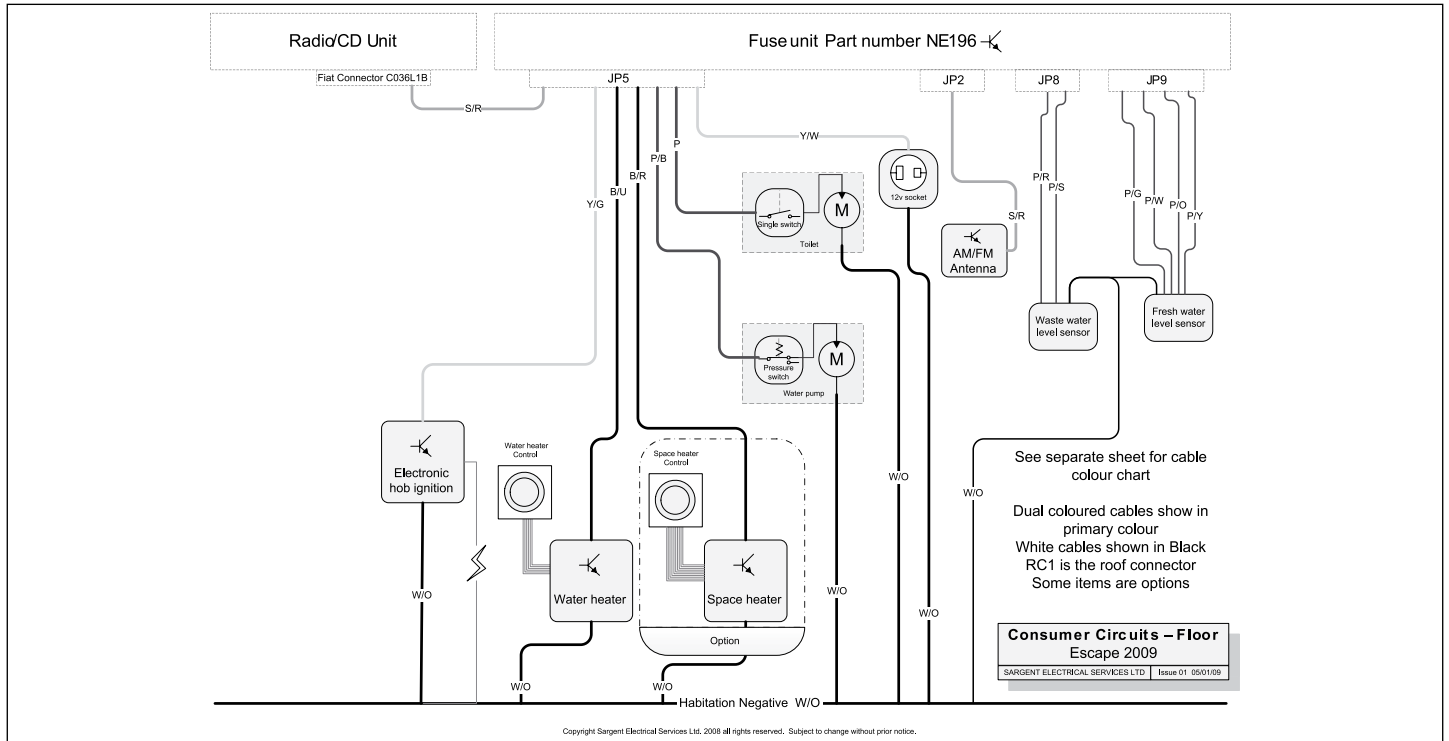

230V CIRCUITS

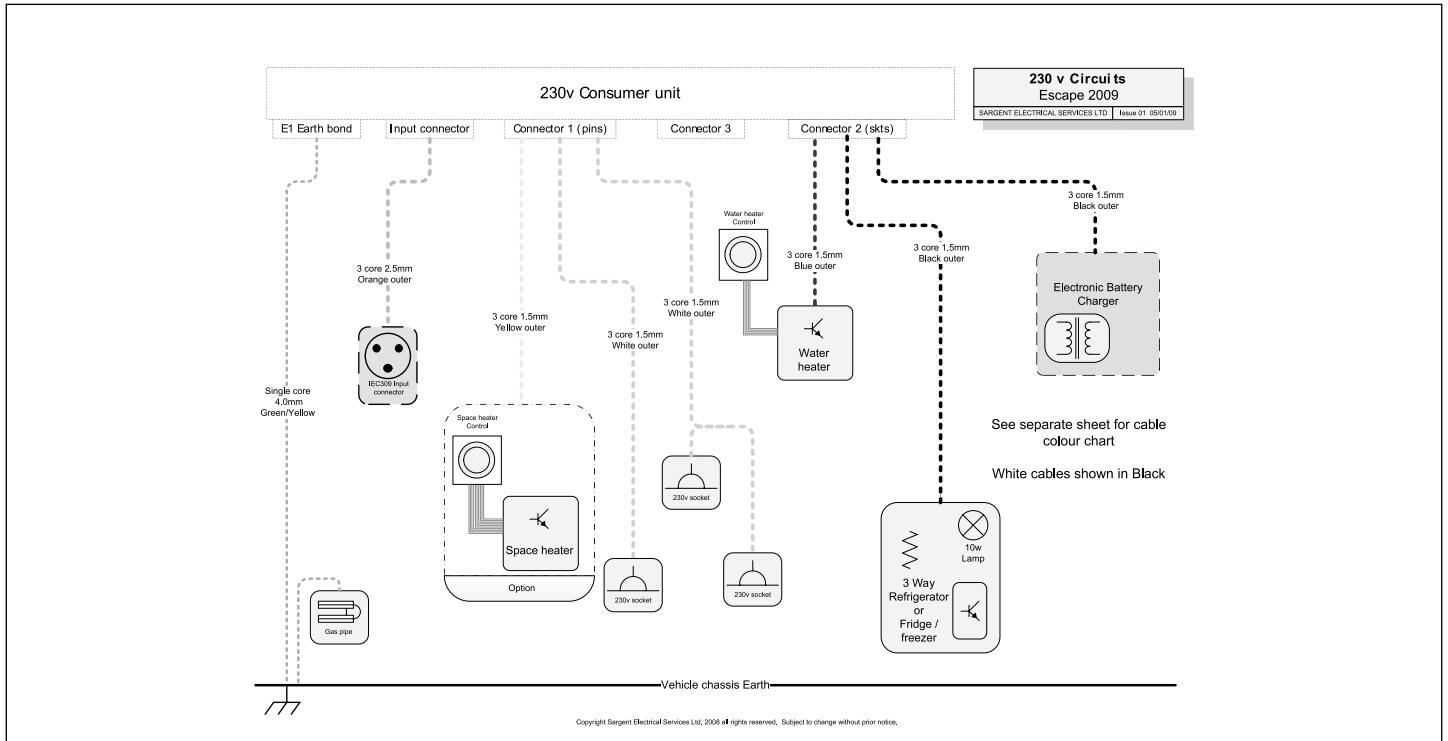

Wiring Diagrams

CABLE COLOUR CHART

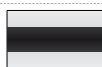

Y/U

Example

Yellow cable with Blue stripe

Cable Colour Chart
Swift 2008

SARGENT ELECTRICAL SERVICES LTD

Issue 01 01/12/07

12v Cable Colours

B	BLACK
N	BROWN
R	RED
O	ORANGE
Y	YELLOW
G	GREEN
U	BLUE
P	PURPLE
S	SLATE GREY
W	WHITE
K	PINK

230v Cable Colours

B	BLACK
N	BROWN
W	WHITE
O	ORANGE
Y	YELLOW
G	GREEN
U	BLUE

Road Lights		
Application	Bulb Reference	Bulb Rating
Front marker light	LED complete lamp	12v < 1w
Side marker light	W5W	12v 5w
Rear high level marker light	C5W	12v 5w
High level stop lamp	T5/13.5	12v 2.3w
Rear indicator lamp	P21	12v 21w
Rear stop / Tail lamp	P21/5W	12v 21w/5w
Rear reverse lamp	P21	12v 21w
Rear fog lamp	P21	12v 21w
Number plate light	C5W	12v 5w
Interior / Other		
Locker downlights	GU4/MR11 Dichroic bulb	GU4 12v 10w
Ceiling lights, twin bulb	Halogen capsule bulb	G4 12v 10w
Ceiling lights, single bulb	Halogen capsule bulb	G4 12v 10w
Luton Lamp	Halogen capsule bulb	G4 12v 10w
China locker lamp	300mm Fluorescent bulb	12v 8w
Awning lamp	P21W bulb	12v 21w

Bulb Replacement

ESCAPE ROAD LIGHTING, COACH-BUILT BODY MOUNTED LAMPS

STOP / TAIL, INDICATOR, FOG AND REVERSE LAMPS

Bulb access is from front / via lens of each lamp.

Remove 2x screws from each light lens and withdraw lens.

Bulbs are a bayonet fitting – apply slight pressure on bulb towards light fitting, and twist to release.

Reverse procedure to re-fit bulb and lens.

Take care when replacing stop/tail lamp bulb, that orientation of bulb is correct – to check, brake light operation should be brighter than tail lamp operation.

UPPER REAR SIDE POSITION LAMPS (RED / CLEAR LENS)

Lens is removed from base to access bulb.

Carefully insert small flat bladed screwdriver into recess in lower edge of lamp base. Apply pressure to release locking barb.

Lift lens upwards and away from lamp base, lower edge first.

Lever bulb out of retaining clips.

Reverse procedure to re-fit bulb and lens.

HIGH LEVEL BRAKE LAMP

Remove 2x screws at either end of lamp, and withdraw lamp away from cowl.

Harness connects via a connector with retention barb into the rear of the lamp. With finger pressure or using a small screwdriver release the barb by pushing it toward the harness, and unplug the harness from the lamp.

Push fit connector back into replacement lamp, and secure lamp to motorhome body with 2x screws.

Lamp retaining screws are fixed into a rubber sleeve with a threaded insert, often known as a rawlnut. If lamp has been removed / re-fitted several times the rubber sleeve may need replacing, these are available through your dealer.

SIDE MARKER / POSITION LAMPS

Bulb access is from rear of lamp.

Check first within motorhome if rear of lamp is visible.

If rear of lamp is visible:

Harness plugs into bulb holder – Twist bulb holder relative to lamp body to release bulb holder from lamp body.

Bulbs are push fit into bulb holder – pull bulb directly away from holder to release.

Reverse procedure to replace bulb in holder, holder in lamp and lamp onto motorhome body

If rear of lamp is not visible:

Remove 2x screws from light fitting, and withdraw whole fitting from motorhome body.

Harness plugs into bulb holder – Twist bulb holder relative to lamp body to release bulb holder from lamp body.

Bulbs are push fit into bulb holder – pull bulb directly away from holder to release.

Reverse procedure to replace bulb in holder, holder in lamp and lamp onto motorhome body.

**FRONT HIGH LEVEL MARKER / POSITION
LAMPS (CLEAR LENS)**

These lamps are LED and have no user serviceable parts inside.

Replacements should be undertaken by your dealer, as the lamps are sealed onto the mounting panel.