

BESSACARR MOTORHOMES,
Dunswell Road, Cottingham, East Yorkshire HU16 4JX.
Tel: 01482 875740 Fax: 01482 840082
email: enquiry@swiftgroup.co.uk

website: www.bessacarmotorhomes.co.uk

A MEMBER OF THE SWIFT GROUP

1084648 Issued OCTOBER 2008



Individually styled
Beautifully built



E500 Series

Specification, wiring diagrams & bulb chart



Individually styled
Beautifully built



CONTENTS

Standard Specifications	2
Optional Specifications	3
Capacities	4
Towing Capabilities	5
Jacking	6
Wiring Diagrams	7
Bulb Replacement	13

Standard Specifications

Model	E510 Compact	E520	E540	E560
Engine	Fiat '100 MultiJet' diesel	Fiat '130 MultiJet' diesel	Fiat '130 MultiJet' diesel	Fiat '130 MultiJet' diesel
Engine Capacity	2198cc	2287cc	2287cc	2287cc
Engine Power	100bhp @ 2900rpm	130bhp @ 3600rpm	130bhp @ 3600rpm	130bhp @ 3600rpm
Torque	250Nm @ 1500rpm	320Nm @ 2000rpm	320Nm @ 2000rpm	320Nm @ 2000rpm
Chassis	Fiat special low line	Fiat special low line	Fiat special low line	Fiat special low line
Wheel base	3.00m/9'10"	4.04m/13'3"	4.04m/13'3"	4.04m/13'3"
Designated Passenger Seats	1	1	1	1
Berths (sleeping positions)	2	2	2	4
Overall Length (no ladder)*	5.90m/19'4"	7.04m/23'1"	7.04m/23'1"	7.04m/23'1"
Overall Width (mirrors folded)	2.31m/7'7"	2.35m/7'8"	2.35m/7'8"	2.35m/7'8"
Overall Height	2.77m/9'1"	2.77m/9'1"	2.77m/9'1"	2.77m/9'1"
Maximum Technical Permissible Laden Mass (A)	3300kg	3500kg	3500kg	3500kg
Mass in Running Order (B)†	2885kg	3150kg	3145kg	3150kg
Maximum User Payload (A-B)	415kg	350kg	355kg	350kg
Essential Habitation Equipment	10kg	10kg	10kg	10kg
Thermal Insulation Grade	Three	Three	Three	Three
Bed Sizes				
Front Double	2.06m x 1.38m/1.24m /6'9" x 4'6"/4'1"		2.11m x 1.81m/1.33m /6'11" x 5'11"/4'4"	2.11m x 1.24m/1.06m /6'11" x 4'1"/3'6"
Front Nearside Single	1.93m x 0.71m/6'4" x 2'4"		1.93m x 0.71m/6'4" x 2'4"	
Front Offside Single	1.78m x 0.71m/5'10" x 2'4"		1.81m x 0.72m/5'11" x 2'4"	1.90m x 1.32m/6'3" x 4'4"
Rear Double		2.11m x 1.33m/6'11" x 4'4"		
Rear Nearside Single		1.79m x 0.71m/5'10" x 2'4"		
Rear Offside Single		1.89m x 0.71m/6'2" x 2'4"		

- NOTE:** 1. **The Maximum User Payload** includes:
- the **conventional load** (this is the allowance for passengers)
 - essential habitation equipment** (items and fluids required for safe and proper functioning of habitation equipment)
 - optional equipment** (items available from the manufacturer over and above the standard specification)
 - personal effects** (those items not covered by the above)
2. The **Mass in Running Order** is the mass of the unladen vehicle including a 75kg allowance for the driver plus engine coolants and 90% of the fuel tank, water tank and gas capacity.
3. PLEASE TAKE CARE TO ENSURE THAT YOU HAVE ALLOWED FOR THE MASSES OF ALL ITEMS YOU INTEND TO CARRY IN THE MOTOR CARAVAN, e.g. passengers, optional equipment, essential habitation equipment and personal effects, such as clothing, food, pets, bicycles, sailboards, sports equipment etc.
4. **WARNING - UNDER NO CIRCUMSTANCES SHOULD THE MAXIMUM TECHNICAL PERMISSIBLE LADEN MASS OF THIS MOTOR CARAVAN BE EXCEEDED.**
- * For optional roof ladder (add 200mm).

Optional Specifications

Model	E510 Compact	E520	E540	E560
Engine	Fiat '130 MultiJet' diesel	Fiat '160 MultiJet' diesel Auto	Fiat '160 MultiJet' diesel Auto	Fiat '160 MultiJet' diesel Auto
Engine Capacity	2287cc	2999cc	2999cc	2999cc
Engine Power	130bhp @ 3600rpm	157bhp	157bhp	157bhp
Torque	320Nm @ 2000rpm	400Nm	400Nm	400Nm
Chassis	Fiat special low line	Fiat special low line	Fiat special low line	Fiat special low line
Wheel base	3.00m/9'10"	4.04m/13'3"	4.04m/13'3"	4.04m/13'3"
Designated Passenger Seats	1	1	1	1
Berths (sleeping positions)	2	2	2	4
Overall Length (no ladder)*	5.90m/19'4"	7.04m/23'1"	7.04m/23'1"	7.04m/23'1"
Overall Width (mirrors folded)	2.31m/7'7"	2.35m/7'8"	2.35m/7'8"	2.35m/7'8"
Overall Height	2.77m/9'1"	2.77m/9'1"	2.77m/9'1"	2.77m/9'1"
Maximum Technical Permissible Laden Mass (A)	3300kg	3500kg	3500kg	3500kg
Mass in Running Order (B)†	2900kg	3217kg	3212kg	3217kg
Maximum User Payload (A-B)	400kg	283kg	288kg	283kg
Essential Habitation Equipment	10kg	10kg	10kg	10kg
Thermal Insulation Grade	Three	Three	Three	Three
Bed Sizes				
Front Double	2.06m x 1.38m/1.24m /6'9" x 4'6"/4'1"		2.11m x 1.81m/1.33m /6'11" x 5'11"/4'4"	2.11m x 1.24m/1.06m /6'11" x 4'1"/3'6"
Front Nearside Single	1.93m x 0.71m/6'4" x 2'4"		1.93m x 0.71m/6'4" x 2'4"	
Front Offside Single	1.78m x 0.71m/5'10" x 2'4"		1.81m x 0.72m/5'11" x 2'4"	1.90m x 1.32m/6'3" x 4'4"
Rear Double		2.11m x 1.33m/6'11" x 4'4"		
Rear Nearside Single		1.79m x 0.71m/5'10" x 2'4"		
Rear Offside Single		1.89m x 0.71m/6'2" x 2'4"		

- NOTE:** 1. **The Maximum User Payload** includes:
- the **conventional load** (this is the allowance for passengers)
 - essential habitation equipment** (items and fluids required for safe and proper functioning of habitation equipment)
 - optional equipment** (items available from the manufacturer over and above the standard specification)
 - personal effects** (those items not covered by the above)
2. The **Mass in Running Order** is the mass of the unladen vehicle including a 75kg allowance for the driver plus engine coolants and 90% of the fuel tank, water tank and gas capacity.
3. **PLEASE TAKE CARE TO ENSURE THAT YOU HAVE ALLOWED FOR THE MASSES OF ALL ITEMS YOU INTEND TO CARRY IN THE MOTOR CARAVAN,** e.g. passengers, optional equipment, essential habitation equipment and personal effects, such as clothing, food, pets, bicycles, sailboards, sports equipment etc.
4. **WARNING - UNDER NO CIRCUMSTANCES SHOULD THE MAXIMUM TECHNICAL PERMISSIBLE LADEN MASS OF THIS MOTOR CARAVAN BE EXCEEDED.**
- * For optional roof ladder (add 200mm).

Capacities

Water Tank Capacities

	Fresh Water Tank	Waste Water Tank	Water Heater	Toilet Tank (Flushing)
E500 Series	90 litre	68 litre	12 litre	0 litre

Gas Capacities

	Capacity
E500 Series	2 x 7kg

The above are recommended gas bottle sizes

NOTICE

For technical data on the base vehicle please refer to manufacturer's handbook

E500 Series Towing Capabilities

Model	Engine / Chassis	MTPLM	Permissible Front Axle Load	Permissible Rear Axle Load	Recommended Maximum Trailer Weight	Gross Train Weight
E510	100 MJ (2.2L) /SWB / ABS	3300kg	1750kg	1900kg	1125kg	5300kg
E510	130MJ (2.3L) / SWB / ABS	3300kg	1750kg	1900kg	1400kg	5800kg
E520	130MJ (2.3L) / LWB / ABS	3500kg	1850kg	2000kg	1340kg	6000kg
E520	160MJ (3.0L) / LWB / ABS / AUTO	3500kg	1850kg	2000kg	1340kg	6000kg
E540	130MJ (2.3L) /LWB / ABS	3500kg	1850kg	2000kg	1340kg	6000kg
E540	160MJ (3.0L) / LWB / ABS / AUTO	3500kg	1850kg	2000kg	1340kg	6000kg
E560	130MJ (2.3L) /LWB / ABS	3500kg	1850kg	2000kg	1340kg	6000kg
E560	160MJ (3.0L) / LWB / ABS / AUTO	3500kg	1850kg	2000kg	1340kg	6000kg

- Single axle conversions - maximum towed trailer mass = 2000kg
- These towing capacities are valid provided the Gross Train Weights as shown on the AL-KO conversion plates are not exceeded.

To ensure adequate road holding, the load on the front axle, under all conditions, must not be less than 40% or more than 70% of the total weight.

Care must be taken when distributing loads. The loadings above are maximum loadings and must not be exceeded under any circumstances.

CAUTION: When fitting a towbar, it must meet certain minimum requirements as specified by Type Approval Regulations. The bar will have marked on it the approval standard (94/20/EC) and the maximum download, or noseweight, that it can accept. It must fit the manufacturer's approved mounting points and must not obscure the towing vehicle's number plate.

Jacking

E500 SERIES

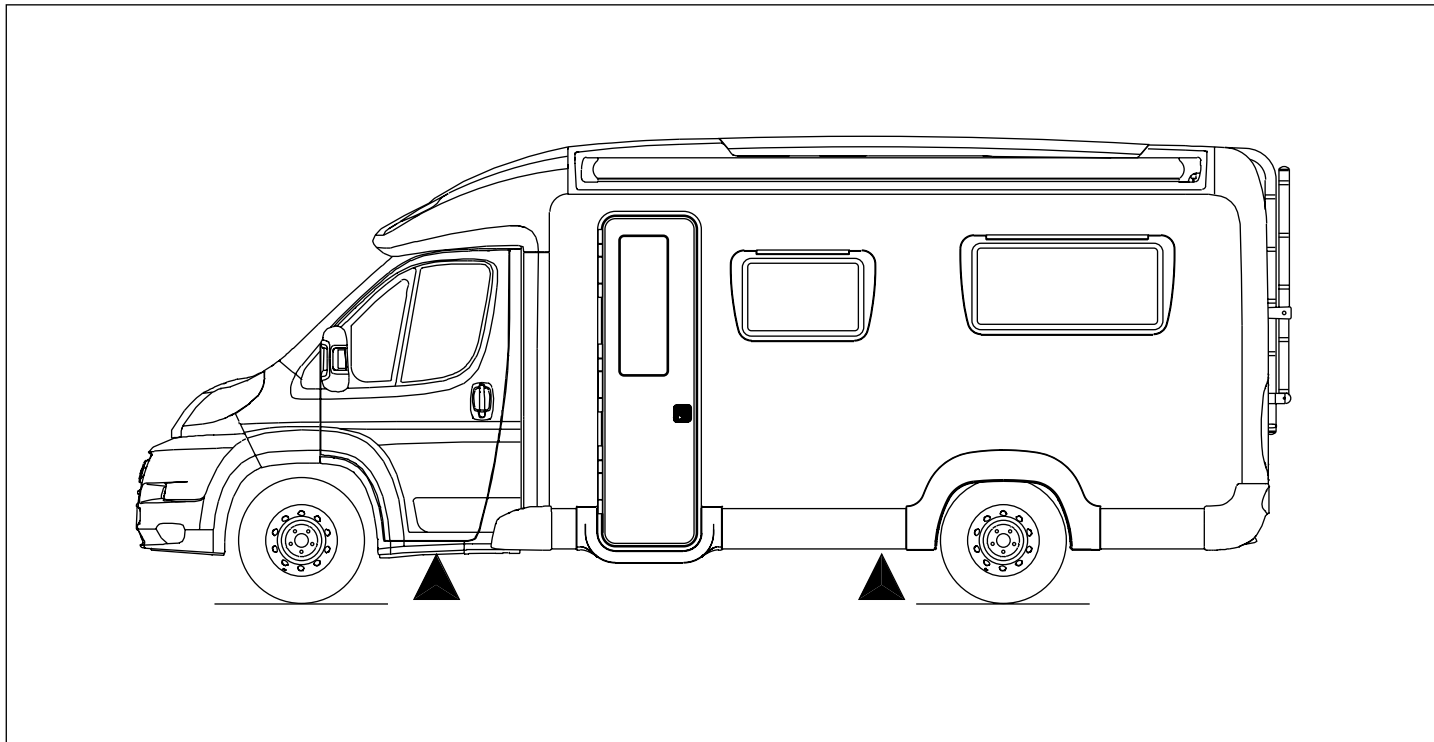

Jacking Point: ▲

ROAD LIGHTING

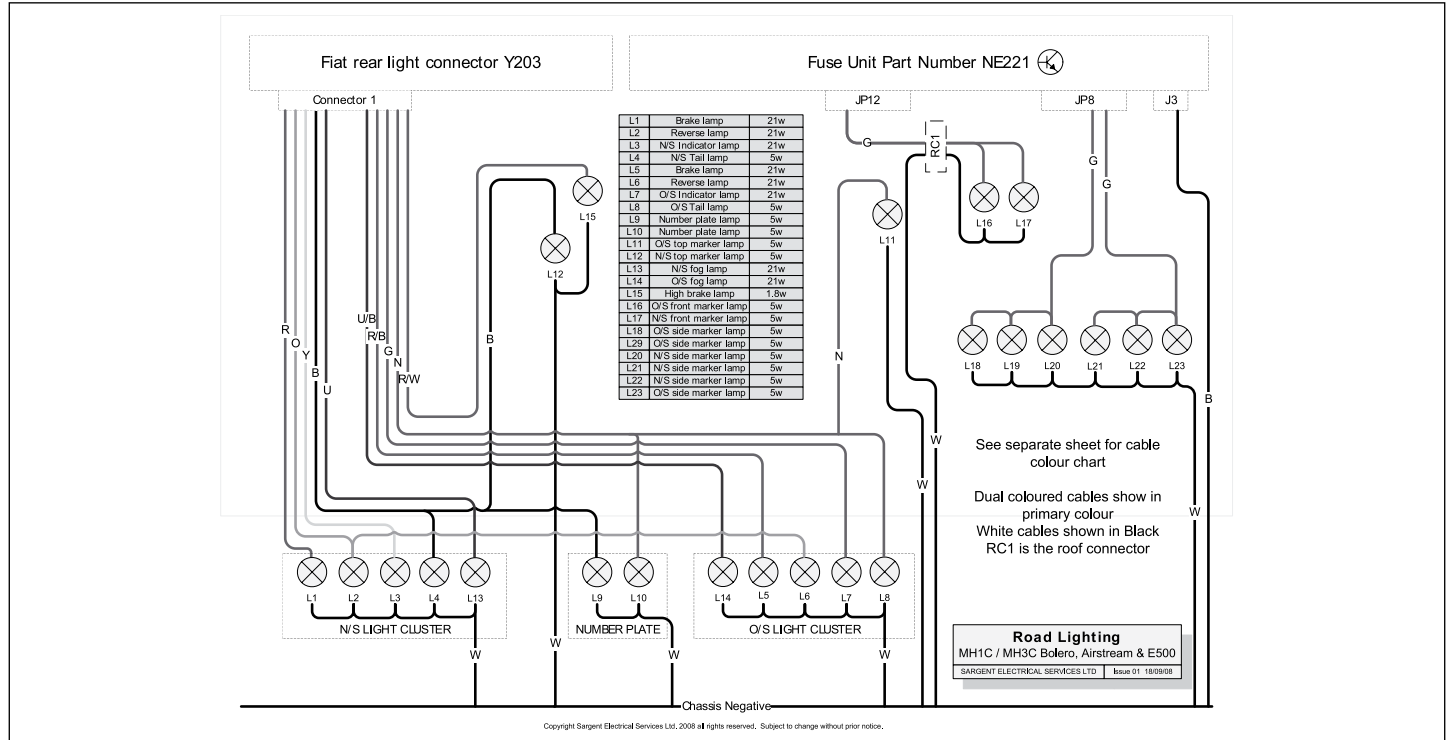

Copyright Sargent Electrical Services Ltd. 2008 all rights reserved. Subject to change without prior notice.

Wiring Diagrams

CONSUMER CIRCUITS – ROOF

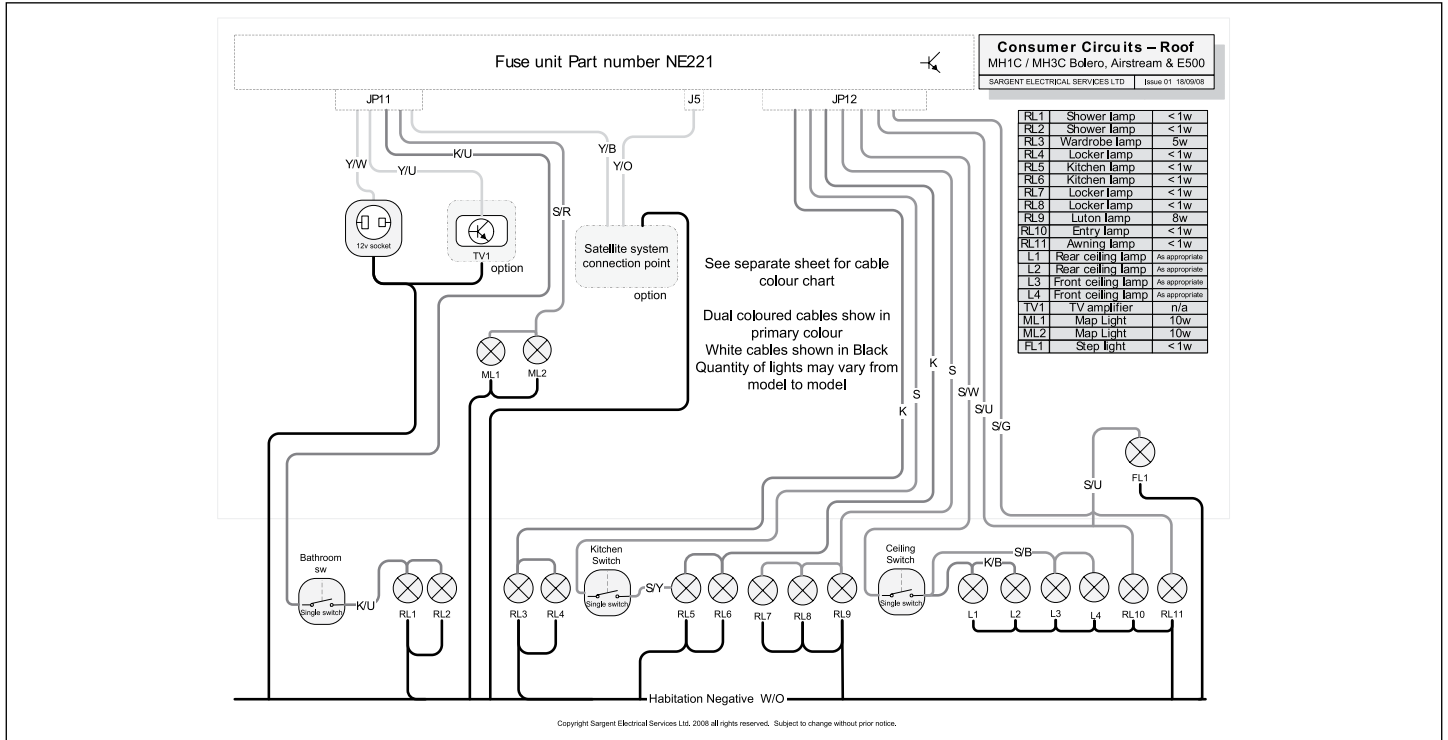

POWER CIRCUITS

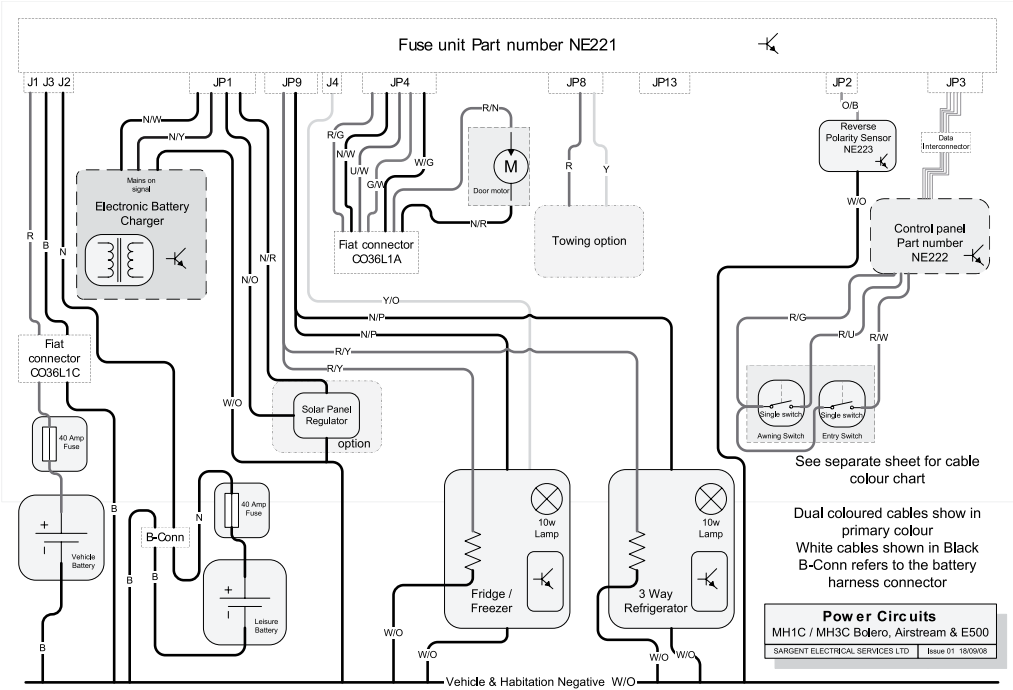

Copyright Sargent Electrical Services Ltd. 2008 all rights reserved. Subject to change without prior notice.

Wiring Diagrams

CONSUMER CIRCUITS – FLOOR

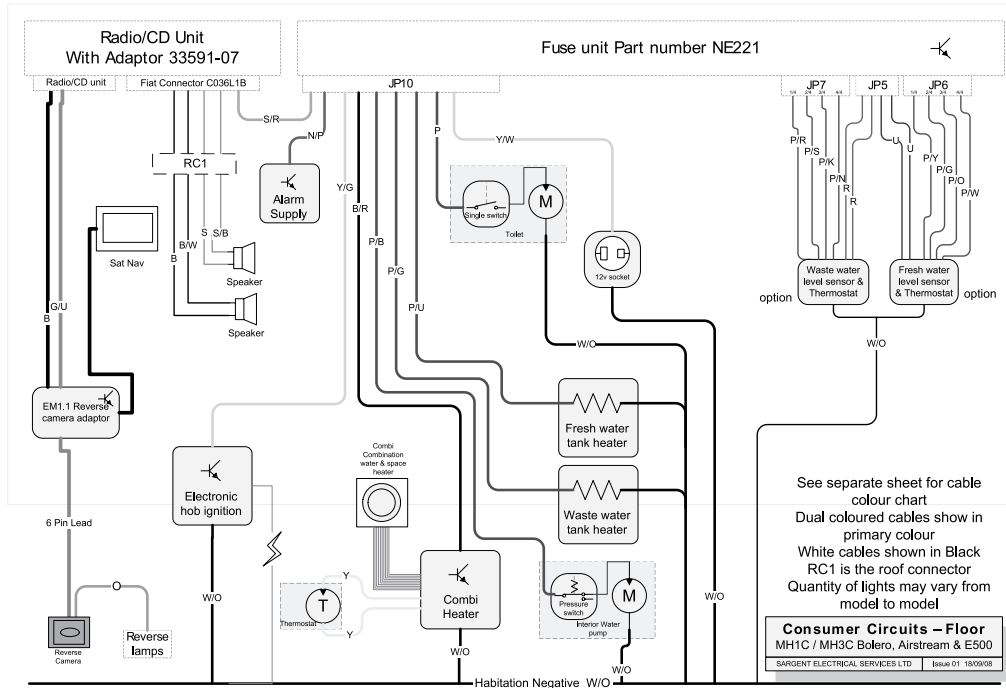

Copyright Sargent Electrical Services Ltd. 2008 all rights reserved. Subject to change without prior notice.

230V CIRCUITS

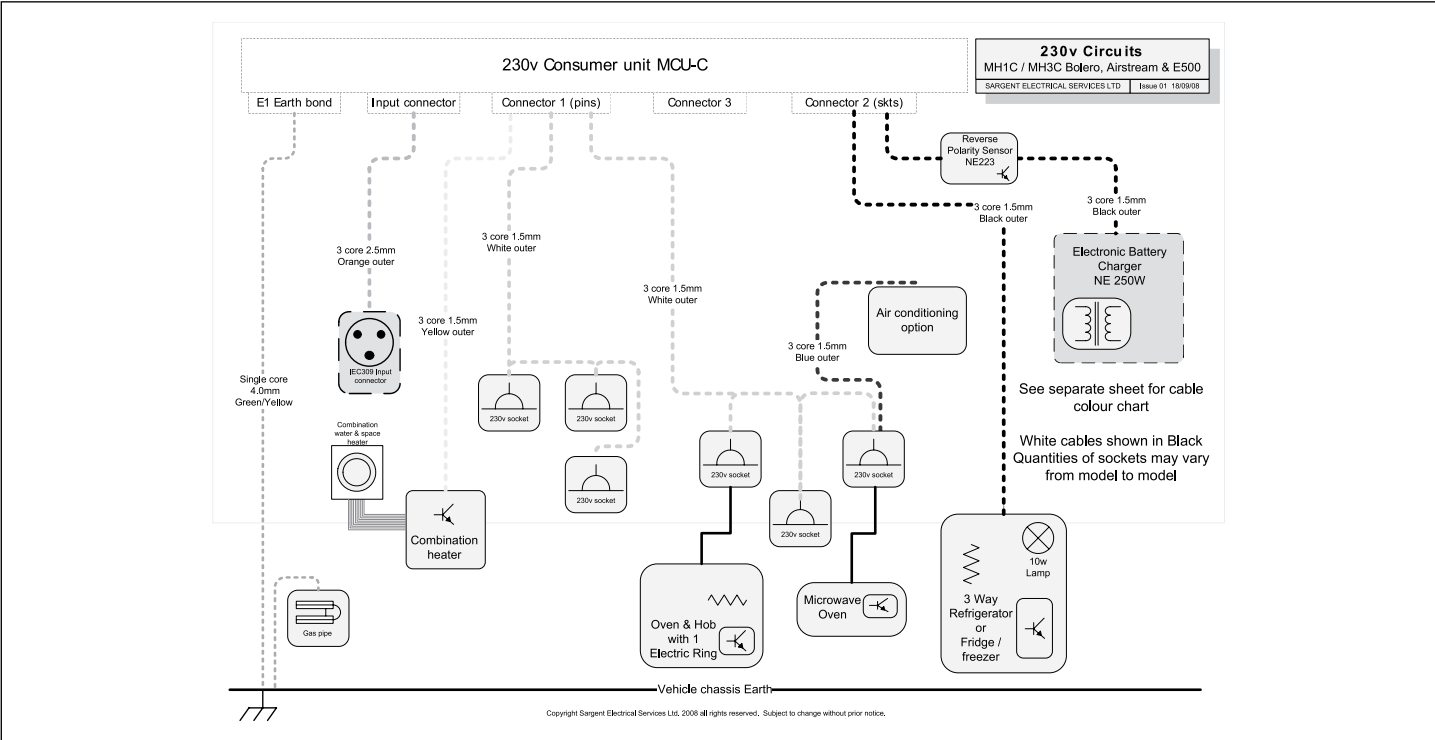

CABLE COLOUR CHART

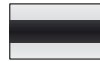

Y/U

Example
Yellow cable with Blue stripe

Cable Colour Chart

Swift Group 2009

SARGENT ELECTRICAL SERVICES LTD

Issue 01 01/09/08

12v Cable Colours

B	BLACK
N	BROWN
R	RED
O	ORANGE
Y	YELLOW
G	GREEN
U	BLUE
P	PURPLE
S	SLATE GREY
W	WHITE
K	PINK

230v Cable Colours

B	BLACK
N	BROWN
W	WHITE
O	ORANGE
Y	YELLOW
G	GREEN
U	BLUE

Bulb Replacement

Road Lights		
Application	Bulb Reference	Bulb Rating
Side marker light	W5W	12v 5w
Rear high level marker light	W5W	12v 5w
High level stop lamp	T5/13.5	12v 2.3w
Rear indicator lamp	PY21 Orange	12v 21w
Rear Stop / Tail lamp	P21/5W	12v 21w / 5w
Rear reverse lamp	P21	12v 21w
Rear fog lamp	P21	12v 21w
Number plate light	C5W	12v 5w
Interior / Other		
Application	Bulb Reference	Bulb Rating
Downlighters, LED, main habitation (dry) areas	FEM0470 complete lamp	12v LED
Downlighters, LED, shower (wet) areas	FEM0441 complete lamp	12v LED
Locker spotlights, LED	FEM0440 complete lamp	12v LED
Panel mounted fluorescent lamps	300mm Fluorescent bulb	12v 8w
Panel mounted fluorescent lamps	600mm Fluorescent bulb	12v 13w
Furniture mounted cold cathode fluorescent lamps	530mm complete lamp, front fixed	12v 5w CCFL
Skylight surround fluorescent lamps	300mm Fluorescent bulb	12v 8w
B-pillar map reading lamps	GU4/MR11 Dichroic bulb	GU4 12v 10w
Entrance step lamp	LED complete lamp	12v LED
Awning lamp, LED	500mm LED complete unit	12v 2.2w LED

Note: Not all lights feature on all models within a range

Replacement instructions

E500 SERIES ROAD LIGHT BULB ACCESS - REPLACEMENT INSTRUCTIONS

REAR INDICATOR LAMPS AND/OR REVERSE LAMPS - REPLACING

Bulb access is from rear of lamp.

The lamp is retained into the rear panel via a spring clip located at the bottom of the lamp body. To release the lamp:

Carefully insert a large flat bladed screwdriver between the top of the lamp body and the plastic of the rear panel.

Using a lever action push the lamp body down against the spring clip.

Once the spring clip is compressed sufficiently, the top of the lamp body can be withdrawn from the rear panel – with the top of the lamp withdrawn the remainder of the lamp will follow.

At the rear of the lamp, a two part metal clip holds the bulb holder in place. To release this:

Insert a flat bladed screwdriver between the rear of the lamp body and the curved section of the two part clip, and use a lever action to dis-engage the clip from the rear of the lamp body.

Continue to move the curved section of the clip away from the lamp body, and the second

straight part will lift away from the back of the bulb holder.

The bulb holder can now be withdrawn from the lamp body.

Bulbs are a bayonet fitting – apply slight pressure on bulb towards the bulb holder, and twist to release.

Re-position the bulb holder into the lamp body and re-engage the two part clip.

Place the lamp body back into the aperture with the spring clip in position against the edge of that aperture. Using a downward force compress the spring clip until the top edge of the lamp body can also be pushed into the aperture.

STOP & TAIL LAMPS - REPLACING

The procedure for these lamps is as for the indicator or reverse lamps.

In addition care is needed when fitting the replacement bulb, that the orientation of the bulb is correct. A simple check is that the lamp when operating as a brake light should be brighter than when operating as a tail lamp, this check can be undertaken before the lamp body is re-fitted into the rear panel.

It is wise to avoid dis-connecting the bulb holder from the harness, as incorrect re-connection can

cause the brake / tail operation of the bulb to be reversed, and/or cause a bulb warning light to illuminate on the Fiat dashboard.

REAR FOG LIGHTS

Bulb access is from rear of lamp.

The light fitting can be accessed from underneath the rear of the vehicle.

At the rear of the lamp, twist the bulb holder relative to the lamp body to release, and withdraw the bulb holder and bulb.

Please note: The visible rubber terminal cover is not fixed to the bulb holder, and it may be easier to grip the bulb holder with this removed.

Bulbs are a bayonet fitting – apply slight pressure on bulb towards light fitting, and twist to release

Re-position the bulb holder into the lamp and twist to lock in place

FRONT OR REAR HIGH LEVEL MARKER / POSITION LAMPS (RED / CLEAR LENSE)

Bulb access is from rear of lamp

Check first within motorhome if rear of lamp is visible

Replacement instructions

If rear of lamp is visible:

Harness plugs into bulb holder – Twist bulb holder relative to lamp body to release bulb holder from lamp body

Bulbs are push fit into bulb holder – pull bulb directly away from holder to release

Reverse procedure to replace bulb in holder, holder in lamp and lamp onto motorhome body

If rear of lamp is not visible:

Remove 2x screws from light fitting, and withdraw whole fitting from motorhome body

Harness plugs into bulb holder – Twist bulb holder relative to lamp body to release bulb holder from lamp body

Bulbs are push fit into bulb holder – pull bulb directly away from holder to release

Reverse procedure to replace bulb in holder, holder in lamp and lamp onto motorhome body

HIGH LEVEL BRAKE LAMP

This lamp is single piece and has no user serviceable parts inside.

Remove the screw at both ends of lamp, and withdraw whole fitting away from rear panel of motorhome.

Please note: The screws which retain the lamp also retain the reverse camera housing.

Unplug the lamp from the harness, by squeezing the small tab on the side of the connector, and pulling the connector away from the lamp.

Re-connect the new lamp to harness, and secure with the original two screws.

Lamp retaining screws are fixed into a rubber sleeve with a threaded insert, often known as a rawlnut. If lamp has been removed and re-fitted several times the rubber sleeve may need replacing, these are available through your dealer.

NUMBER PLATE LAMPS

Bulb access is via the front lense of each lamp

Remove the two screws in the lense of the lamp, and remove

Lever the bulb out of retaining clips

Reverse the procedure to re-fit a new bulb and the light lense

SIDE MARKER / POSITION LAMPS

Bulb access is from rear of lamp

If rear of lamp is visible from inside the vehicle:

Depending on the location, a small brown plastic

cover may be present covering the connections to the lamp. Remove the screws in the cover to release and access the rear of the lamp.

The harness plugs directly into the bulb holder – twist the bulb holder relative to the lamp body to release, and withdraw the bulb holder and bulb.

Bulbs are push fit into bulb holder – pull bulb directly away from holder to release

Reverse the procedure to replace the bulb in the holder, holder in the lamp and the lamp onto the motorhome body. Replace plastic cover.

If rear of lamp is not visible from inside the vehicle:

Remove the 2 screws from the front of the light fitting, and withdraw the whole fitting from motorhome body

The harness plugs directly into the bulb holder – twist the bulb holder relative to the lamp body to release, and withdraw the bulb holder and bulb.

Bulbs are push fit into bulb holder – pull bulb directly away from holder to release

Reverse the procedure to replace the bulb in the holder, holder in the lamp and the lamp onto the motorhome body.

