

ACE Motorhomes, Dunswell Road,  
Cottingham, East Yorkshire HU16 4JX.  
Tel: 01482 875740 Fax: 01482 840082  
email: enquiry@swiftgroup.co.uk  
**website: [www.acemotorhomes.co.uk](http://www.acemotorhomes.co.uk)**

A MEMBER OF THE SWIFT GROUP

1085647 Issued October 2008



*Enjoy the freedom*

# Ace Adventurer

Specification, wiring diagrams & bulb chart



*Enjoy the freedom*





# CONTENTS

Standard Specifications .....	2
Optional Specifications .....	3
Capacities .....	4
Towing Capabilities .....	5
Jacking .....	6
Wiring Diagrams .....	7
Bulb Replacement .....	13

# Standard Specifications

Model	Adventurer 630EK	Adventurer 635EK	Adventurer 680FB	Adventurer 685FB	Adventurer 695EL
Engine	Fiat '130 MultiJet' diesel	Fiat '130 MultiJet' diesel	Fiat '130 MultiJet' diesel	Fiat '130 MultiJet' diesel	Fiat '130 MultiJet' diesel
Engine Capacity	2287cc	2287cc	2287cc	2287cc	2287cc
Engine Power	130bhp @ 3600rpm	130bhp @ 3600rpm	130bhp @ 3600rpm	130bhp @ 3600rpm	130bhp @ 3600rpm
Torque	320Nm @ 2000rpm	320Nm @ 2000rpm	320Nm @ 2000rpm	320Nm @ 2000rpm	320Nm @ 2000rpm
Chassis	Fiat Chassis Cab	Fiat Chassis Cab	Fiat Maxi Chassis Cab	Fiat Maxi Chassis Cab	Fiat Maxi Chassis Cab
Wheel base	3.80m/12'6"	3.45m/11'4"	4.04m/13'3"	4.04m/13'3"	4.04m/13'3"
Designated Passenger Seats	1	5	3	3	3
Berths (sleeping positions)	2	5	4	4	4
Overall Length (no ladder)*	6.82m/22'4"	6.58m/21'7"	7.08m/23'3"	7.08m/23'3"	7.08m/23'3"
Overall Width (mirrors folded)	2.35m/7'8"	2.35m/7'8"	2.35m/7'8"	2.35m/7'8"	2.35m/7'8"
Overall Height	2.95m/9'8"	3.05m/10'0"	2.95m/9'8"	3.05m/10'0"	3.05m/10'0"
Maximum Technical Permissible Laden Mass (A)	3500kg	4005kg	4005kg	4005kg	4005kg
Mass in Running Order (B)†	3210kg	3310kg	3370kg	3410kg	3420kg
Maximum User Payload (A-B)	290Kg	695Kg	635kg	595kg	585kg
Essential Habitation Equipment	10kg	10kg	10kg	10kg	10kg
Thermal Insulation Grade	Three	Three	Three	Three	Three
Bed Sizes					
Front Double	2.11m x 1.80m/6'11" x 5'11"	1.85m x 1.30m/6'1" x 4'3"	2.13m x 1.53m/7'0" x 5'0"/3'6"		
Front Nearside Single	1.80m x 0.72m/5'11" x 2'4"	1.85m x 0.97m/6'1" x 3'2"			
Front Offside Single	1.80m x 0.72m/5'11" x 2'4"	1.82m x 0.71m/6'0" x 2'4"			
Rear Double			1.90m x 1.31m/6'3" x 4'4"	1.90m x 1.31m/6'3" x 4'4"	2.11m x 1.77m/6'11" x 5'10"
Rear Nearside Single					1.77m x 0.70m/5'10" x 2'4"
Rear Offside Single					1.89m x 0.70m/6'2" x 2'4"
Overcab Bed		1.91m x 1.37m/6'3" x 4'6"		1.91m x 1.37m/6'3" x 4'6"	1.91m x 1.37m/6'3" x 4'6"

- NOTE:** 1. The **Maximum User Payload** includes:
- the **conventional load** (this is the allowance for passengers)
  - essential habitation equipment** (items and fluids required for safe and proper functioning of habitation equipment)
  - optional equipment** (items available from the manufacturer over and above the standard specification)
  - personal effects** (those items not covered by the above)
2. The **Mass in Running Order** is the mass of the unladen vehicle including a 75kg allowance for the driver plus engine coolants and 90% of the fuel tank, water tank and gas capacity.
3. PLEASE TAKE CARE TO ENSURE THAT YOU HAVE ALLOWED FOR THE MASSES OF ALL ITEMS YOU INTEND TO CARRY IN THE MOTOR CARAVAN, e.g. passengers, optional equipment, essential habitation equipment and personal effects, such as clothing, food, pets, bicycles, sailboards, sports equipment etc.
4. **WARNING - UNDER NO CIRCUMSTANCES SHOULD THE MAXIMUM TECHNICAL PERMISSIBLE LADEN MASS OF THIS MOTOR CARAVAN BE EXCEEDED.**
- \* For optional roof ladder (add 200mm).

# Optional Specifications

Model	Adventurer 630EK	Adventurer 630EK	Adventurer 630EK	Adventurer 635EK	Adventurer 680FB	Adventurer 685FB	Adventurer 695EL
Engine	Fiat '160 MultiJet' diesel Auto	Fiat '130 MultiJet' diesel	Fiat '160 MultiJet' diesel Auto	Fiat '160 MultiJet' diesel Auto	Fiat '160 MultiJet' diesel Auto	Fiat '160 MultiJet' diesel Auto	Fiat '160 MultiJet' diesel Auto
Engine Capacity	2999cc	2287cc	2999cc	2999cc	2999cc	2999cc	2999cc
Engine Power	157bhp	130bhp @ 3600rpm	157bhp	157bhp	157bhp	157bhp	157bhp
Torque	400Nm	320Nm @ 2000rpm	400Nm	400Nm	400Nm	400Nm	400Nm
Chassis	Fiat Chassis Cab	Fiat Chassis Cab	Fiat Chassis Cab	Fiat Chassis Cab	Fiat Maxi Chassis Cab	Fiat Maxi Chassis Cab	Fiat Maxi Chassis Cab
Wheel base	3.80m/12'6"	3.80m/12'6"	3.80m/12'6"	3.45m/11'4"	4.04m/13'3"	4.04m/13'3"	4.04m/13'3"
Designated Passenger Seats	1	1	1	5	3	3	3
Berths (sleeping positions)	2	2	2	5	4	4	4
Overall Length (no ladder)*	6.82m/22'4"	6.82m/22'4"	6.82m/22'4"	6.58m/21'7"	7.08m/23'3"	7.08m/23'3"	7.08m/23'3"
Overall Width (mirrors folded)	2.35m/7'8"	2.35m/7'8"	2.35m/7'8"	2.35m/7'8"	2.35m/7'8"	2.35m/7'8"	2.35m/7'8"
Overall Height	2.95m/9'8"	2.95m/9'8"	2.95m/9'8"	3.05m/10'0"	2.95m/9'8"	3.05m/10'0"	3.05m/10'0"
Maximum Technical Permissible Laden Mass (A)	3500kg	4005kg	4005kg	4005kg	4005kg	4005kg	4005kg
Mass in Running Order (B)†	3277kg	3250kg	3317kg	3377kg	3437kg	3477kg	3487kg
Maximum User Payload (A-B)	223Kg	755Kg	688 Kg	628Kg	568kg	528kg	518kg
Essential Habitation Equipment	10kg	10kg	10kg	10kg	10kg	10kg	10kg
Thermal Insulation Grade	Three	Three	Three	Three	Three	Three	Three
Bed Sizes							
Front Double	2.11m x 1.80m/6'11" x 5'11"	2.11m x 1.80m/6'11" x 5'11"	2.11m x 1.80m/6'11" x 5'11"	1.85m x 1.30m/6'1" x 4'3"	2.13m x 1.53m/1.06m/7'0" x 5'0"/3'6"		
Front Nearside Single	1.80m x 0.72m/5'11" x 2'4"	1.80m x 0.72m/5'11" x 2'4"	1.80m x 0.72m/5'11" x 2'4"	1.85m x 0.97m/6'1" x 3'2"			
Front Offside Single	1.80m x 0.72m/5'11" x 2'4"	1.80m x 0.72m/5'11" x 2'4"	1.80m x 0.72m/5'11" x 2'4"	1.82m x 0.71m/6'0" x 2'4"			
Rear Double					1.90m x 1.31m/6'3" x 4'4"	1.90m x 1.31m/6'3" x 4'4"	2.11m x 1.77m/6'11" x 5'10"
Rear Nearside Single							1.77m x 0.70m/5'10" x 2'4"
Rear Offside Single							1.89m x 0.70m/6'2" x 2'4"
Overcab Bed				1.91m x 1.37m/6'3" x 4'6"		1.91m x 1.37m/6'3" x 4'6"	1.91m x 1.37m/6'3" x 4'6"

- NOTE:** 1. The **Maximum User Payload** includes:
- the **conventional load** (this is the allowance for passengers)
  - essential habitation equipment** (items and fluids required for safe and proper functioning of habitation equipment)
  - optional equipment** (items available from the manufacturer over and above the standard specification)
  - personal effects** (those items not covered by the above)
2. The **Mass in Running Order** is the mass of the unladen vehicle including a 75kg allowance for the driver plus engine coolants and 90% of the fuel tank, water tank and gas capacity.
3. PLEASE TAKE CARE TO ENSURE THAT YOU HAVE ALLOWED FOR THE MASSES OF ALL ITEMS YOU INTEND TO CARRY IN THE MOTOR CARAVAN, e.g. passengers, optional equipment, essential habitation equipment and personal effects, such as clothing, food, pets, bicycles, sailboards, sports equipment etc.
4. **WARNING - UNDER NO CIRCUMSTANCES SHOULD THE MAXIMUM TECHNICAL PERMISSIBLE LADEN MASS OF THIS MOTOR CARAVAN BE EXCEEDED.**
- \* For optional roof ladder (add 200mm).

# Capacities

## Water Tank Capacities

	<b>Fresh Water Tank</b>	<b>Waste Water Tank</b>	<b>Water Heater</b>	<b>Toilet Tank (Flushing)</b>
Adventurer	90 litre	68 litre	12 litre	0 litre

## Gas Capacities

	<b>Capacity</b>
Adventurer	2 x 7kg

The above are recommended gas bottle sizes

## NOTICE

For technical data on the base vehicle please refer to manufacturer's handbook

## Adventurer Towing Capabilities

Model	Engine / Chassis	MTPLM	Permissible Front Axle Load	Permissible Rear Axle Load	Recommended Maximum Trailer Weight	Gross Train Weight
Adventurer 630EK	130MJ (2.3L) /MLWB/ABS	3500kg	1850kg	2000kg	1330kg	6000kg
Adventurer 630EK	130MJ (2.3L) /MLWB/ABS	4005kg	2100kg	2400kg	1330kg	6505kg
Adventurer 630EK	160MJ (3.0L) /MLWB/ABS	3500kg	2100kg	2400kg	1330kg	6000kg
Adventurer 630EK	160MJ (3.0L) /MLWB/ABS/AUTO	4005kg	2100kg	2400kg	1330kg	6505kg
Adventurer 635EK	130MJ (2.3L) /LWB/ABS	4005kg	2100kg	2400kg	1240kg	6505kg
Adventurer 635EK	160MJ (3.0L) /LWB/ABS/AUTO	4005kg	2100kg	2400kg	1240kg	6505kg
Adventurer 680FB	130MJ (2.3L) /LWB/ABS	4005kg	2100kg	2400kg	1290kg	6505kg
Adventurer 680FB	160MJ (3.0L) /LWB/ABS/AUTO	4005kg	2100kg	2400kg	1290kg	6505kg
Adventurer 685FB	130MJ (2.3L) /LWB/ABS	4005kg	2100kg	2400kg	1290kg	6505kg
Adventurer 685FB	160MJ (3.0L) /LWB/ABS/AUTO	4005kg	2100kg	2400kg	1290kg	6505kg
Adventurer 695EL	130MJ (2.3L) /LWB/ABS	4005kg	2100kg	2400kg	1290kg	6505kg
Adventurer 695EL	160MJ (3.0L) /LWB/ABS/AUTO	4005kg	2100kg	2400kg	1290kg	6505kg

- Single axle conversions - maximum towed trailer mass = 2000kg
- These towing capacities are valid provided the Gross Train Weights as shown on the AL-KO conversion plates are not exceeded.

To ensure adequate road holding, the load on the front axle, under all conditions, must not be less than 40% or more than 70% of the total weight.

Care must be taken when distributing loads. The loadings above are maximum loadings and must not be exceeded under any circumstances.

**CAUTION:** When fitting a towbar, it must meet certain minimum requirements as specified by Type Approval Regulations. The bar will have marked on it the approval standard (94/20/EC) and the maximum download, or nose weight, that it can accept. It must fit the manufacturer's approved mounting points and must not obscure the towing vehicle's number plate.

# Jacking

## ADVENTURER

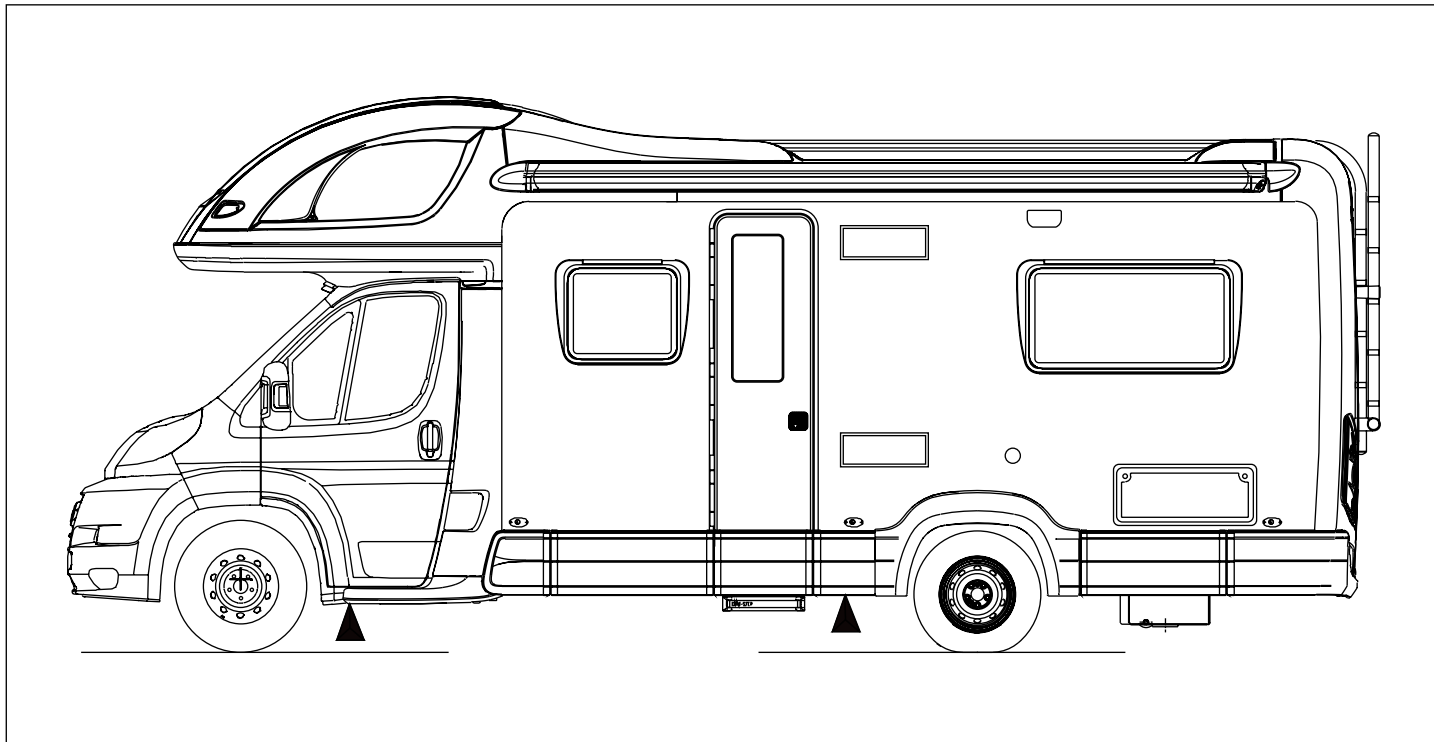

Jacking Point: ▲



# Wiring Diagrams

## CONSUMER CIRCUITS – ROOF

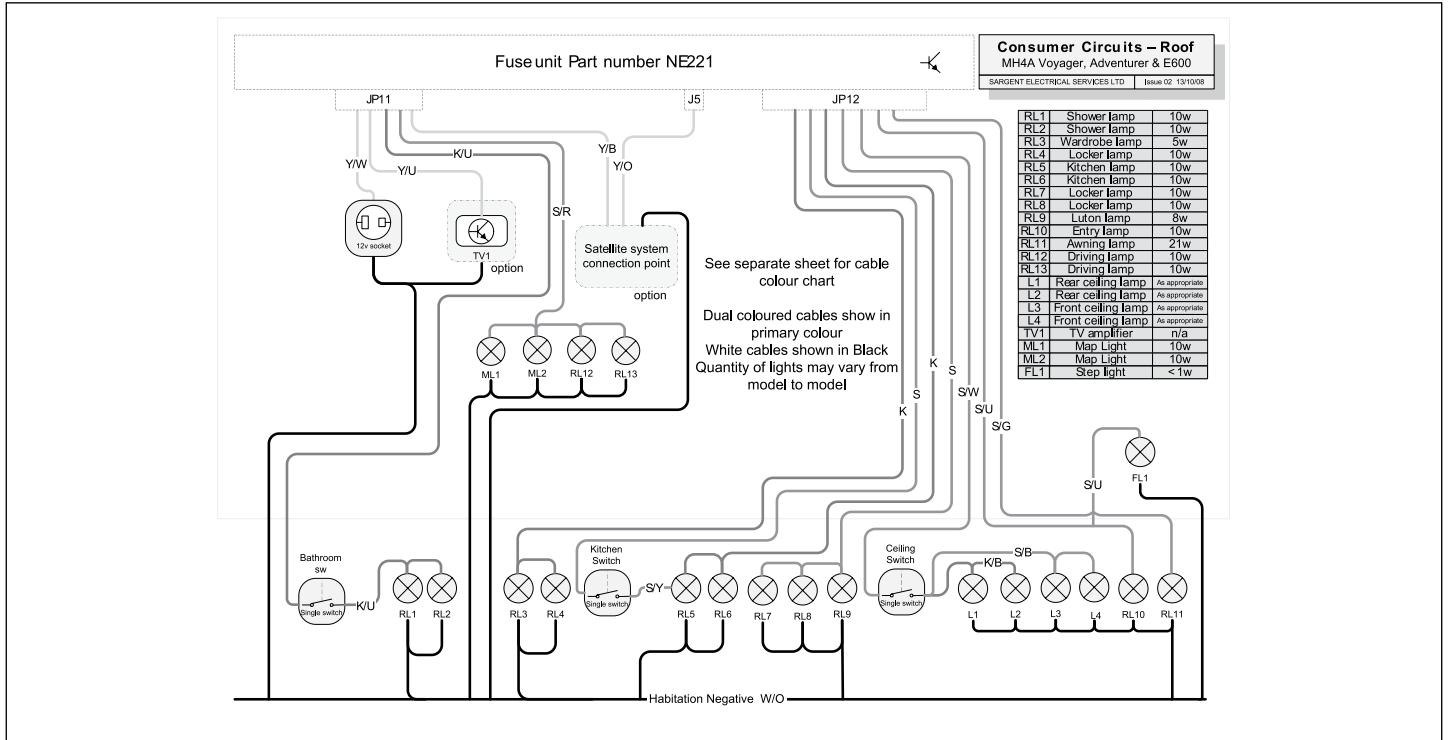

## POWER CIRCUITS

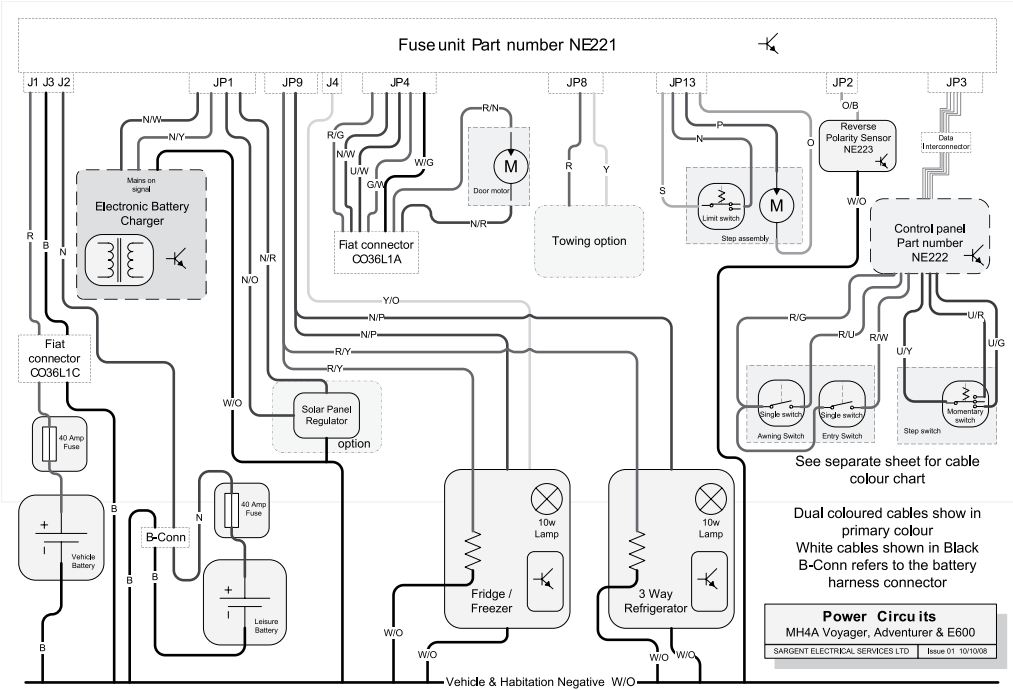

# Wiring Diagrams

## CONSUMER CIRCUITS – FLOOR

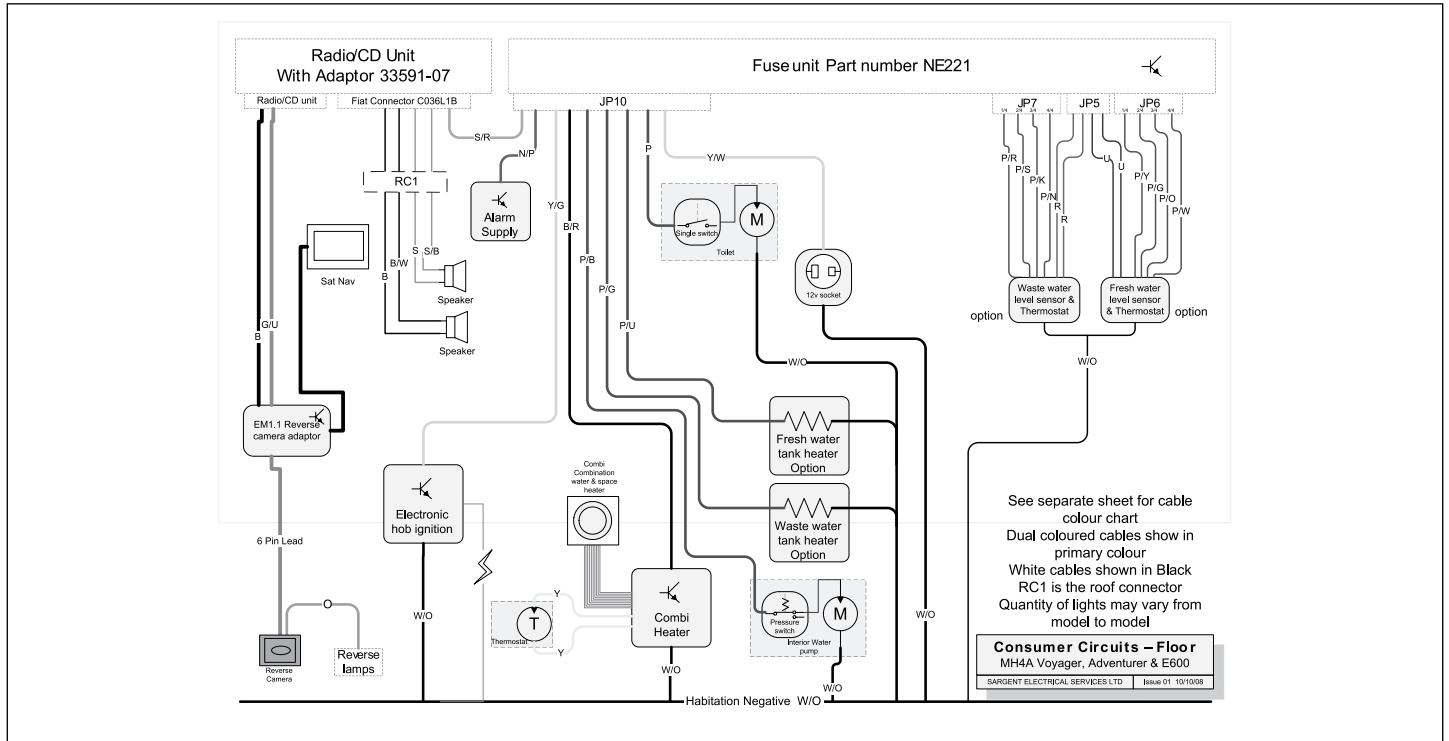

## 230V CIRCUITS

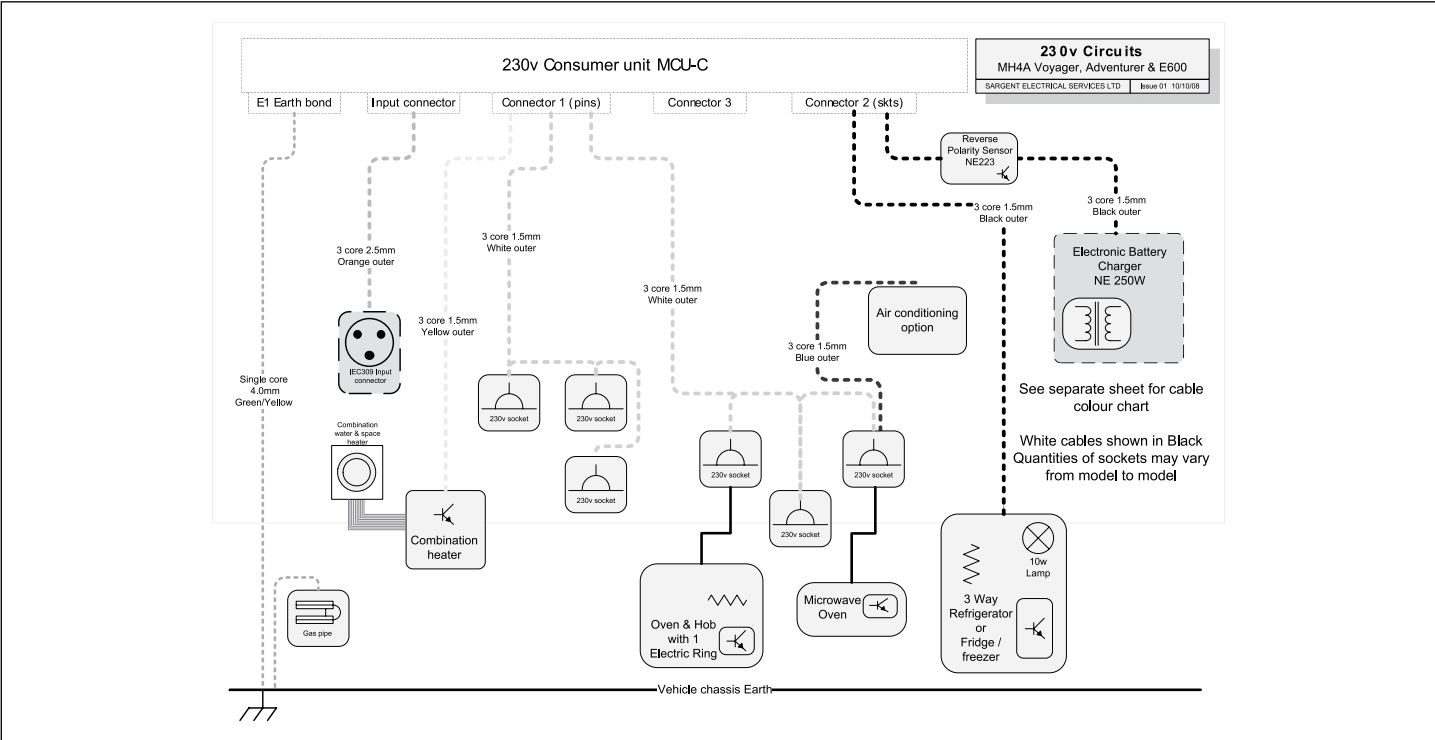

## CABLE COLOUR CHART



**Y/U**

Example  
Yellow cable with Blue stripe

### Cable Colour Chart

Swift Group 2009

SARGENT ELECTRICAL SERVICES LTD

Issue 01 01/09/08

### 12v Cable Colours

<b>B</b>	BLACK
<b>N</b>	BROWN
<b>R</b>	RED
<b>O</b>	ORANGE
<b>Y</b>	YELLOW
<b>G</b>	GREEN
<b>U</b>	BLUE
<b>P</b>	PURPLE
<b>S</b>	SLATE GREY
<b>W</b>	WHITE
<b>K</b>	PINK

### 230v Cable Colours

<b>B</b>	BLACK
<b>N</b>	BROWN
<b>W</b>	WHITE
<b>O</b>	ORANGE
<b>Y</b>	YELLOW
<b>G</b>	GREEN
<b>U</b>	BLUE

## Bulb Replacement

<b>Road Lights</b>		
<b>Application</b>	<b>Bulb Reference</b>	<b>Bulb Rating</b>
Front marker light	LED complete lamp	12v <1w
Side marker light	W5W	12v 5w
Rear high level marker light	LED complete lamp	12v <1w
High level stop lamp	T5/13.5	12v 2.3w
Rear indicator lamp	PY21 Orange	12v 21w
Rear Stop / Tail lamp	P21/5W	12v 21w / 5w
Rear reverse lamp	P21	12v 21w
Rear fog lamp	P21	12v 21w
Number plate light	C5W	12v 5w
<b>Interior / Other</b>		
Downlighters	Halogen capsule bulb	G4 12v 10w
Locker spotlights	GU5.3/MR16 Dichroic bulb	GU5.3 12v 10w
China locker fluorescent lamp	300mm Fluorescent bulb	12v 8w
Panel mounted fluorescent lamps	300mm Fluorescent bulb	12v 8w
Panel mounted fluorescent lamps	600mm Fluorescent bulb	12v 13w
Skylight surround fluorescent lamps	300mm Fluorescent bulb	12v 8w
Luton fluorescent lamps	300mm Fluorescent bulb	12v 8w
B-pillar map reading lamps	GU4/MR11 Dichroic bulb	GU4 12v 10w
Entrance step lamp	LED complete lamp	12v LED
Wardrobe lamp	Halogen capsule bulb	GU4 12v 5w
Awning lamp	P21W bulb	12v 21w

Note: Not all lights feature on all models within a range

## Replacement instructions

### **ADVENTURER ROAD LIGHT BULB ACCESS**

#### **REAR INDICATOR LAMPS AND/OR REVERSE LAMPS - REPLACING:**

Bulb access is from rear of lamp.

The lamp is retained into the rear panel via a spring clip located at the bottom of the lamp body. To release the lamp:

Carefully insert a large flat bladed screwdriver between the top of the lamp body and the plastic of the rear panel.

Using a lever action push the lamp body down against the spring clip.

Once the spring clip is compressed sufficiently, the top of the lamp body can be withdrawn from the rear panel – with the top of the lamp withdrawn the remainder of the lamp will follow.

At the rear of the lamp, a two part metal clip holds the bulb holder in place. To release this:

Insert a flat bladed screwdriver between the rear of the lamp body and the curved section of the two part clip, and use a lever action to disengage the clip from the rear of the lamp body.

Continue to move the curved section of the clip away from the lamp body, and the second straight part will lift away from the back of the bulb holder.

The bulb holder can now be withdrawn from the lamp body.

Bulbs are a bayonet fitting – apply slight pressure on bulb towards the bulb holder, and twist to release.

Re-position the bulb holder into the lamp body and re-engage the two part clip.

Place the lamp body back into the aperture with the spring clip in position against the edge of that aperture. Using a downward force compress the spring clip until the top edge of the lamp body can also be pushed into the aperture.

#### **STOP & TAIL LAMPS - REPLACING**

The procedure for these lamps is as for the indicator or reverse lamps.

In addition care is needed when fitting the replacement bulb, that the orientation of the bulb is correct. A simple check is that the lamp when operating as a brake light should be brighter than when operating as a tail lamp, this check can be undertaken before the lamp body is re-fitted into the rear panel.

It is wise to avoid dis-connecting the bulb holder from the harness, as incorrect re-connection can cause the brake / tail operation of the bulb to be reversed, an/or cause an bulb warning light to illuminate on the Fiat dashboard.

#### **REAR FOG LIGHTS**

Bulb access is from rear of lamp.

The light fitting can be accessed from underneath the rear of the vehicle.

At the rear of the lamp, twist the bulb holder relative to the lamp body to release, and withdraw the bulb holder and bulb.

Please note: The visible rubber terminal cover is not fixed to the bulb holder, and it may be easier to grip the bulb holder with this removed.

Bulbs are a bayonet fitting – apply slight pressure on bulb towards light fitting, and twist to release

Re-position the bulb holder into the lamp and twist to lock in place

## Replacement instructions

### **FRONT OR REAR HIGH LEVEL MARKER / POSITION LAMPS (RED / CLEAR LENSE)**

These lamps are LED and have no user serviceable parts inside.

Replacements should be undertaken by your dealer, as the lamps are sealed onto the mounting panel.

### **HIGH LEVEL BRAKE LAMP**

This lamp is single piece and has no user serviceable parts inside.

Remove the screw at both ends of lamp, and withdraw whole fitting away from rear panel of motorhome.

Please note : The screws which retain the lamp also retain the reverse camera housing.

Unplug the lamp from the harness, by squeezing the small tab on the side of the connector, and pulling the connector away from the lamp.

Re-connect the new lamp to harness, and secure with the original two screws.

Lamp retaining screws are fixed into a rubber sleeve with a threaded insert, often known as a rawlnut. If lamp has been removed and re-fitted several times the rubber sleeve may need replacing, these are available through your dealer.

### **NUMBER PLATE LAMPS**

Bulb access is from via the front lense of each lamp

Remove the two screws in the lense of the lamp, and remove

Lever the bulb out of retaining clips

Reverse the procedure to re-fit a new bulb and the light lense

### **SIDE MARKER / POSITION LAMPS**

Bulb access is from rear of lamp

If rear of lamp is visible from inside the vehicle:

Depending on the location, a small brown plastic cover may be present covering the connections to the lamp. Remove the screws in the cover to release and access the rear of the lamp.

The harness plugs directly into the bulb holder – twist the bulb holder relative to the lamp body to release, and withdraw the bulb holder and bulb.

Bulbs are push fit into bulb holder – pull bulb directly away from holder to release

Reverse the procedure to replace the bulb in the holder, holder in the lamp and the lamp onto the motorhome body. Replace plastic cover.

If rear of lamp is not visible from inside the vehicle:

Remove the 2 screws from the front of the light fitting, and withdraw the whole fitting from motorhome body

The harness plugs directly into the bulb holder – twist the bulb holder relative to the lamp body to release, and withdraw the bulb holder and bulb.

Bulbs are push fit into bulb holder – pull bulb directly away from holder to release

Reverse the procedure to replace the bulb in the holder, holder in the lamp and the lamp onto the motorhome body.

### **NUMBER PLATE LAMPS**

Bulb access is from via the front lense of each lamp

Remove the two screws in the lense of the lamp, and remove

Lever the bulb out of retaining clips

Reverse the procedure to re-fit a new bulb and the light lense



