



Enjoy the freedom

Ace Motorhomes

Dunswell Road, Cottingham, East Yorkshire HU16 4JX.

Tel: 01482 875740 Fax: 01482 840082

email: enquiry@swiftgroup.co.uk

website: www.acemotorhomes.co.uk

A MEMBER OF THE SWIFT GROUP



***SPECIFICATION, WIRING DIAGRAMS
AND BULB CHART***

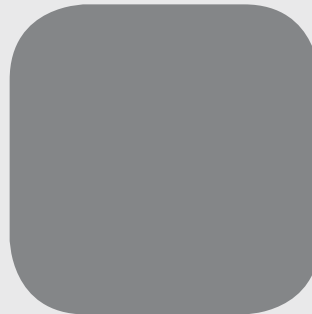
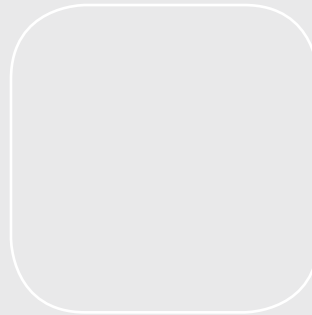
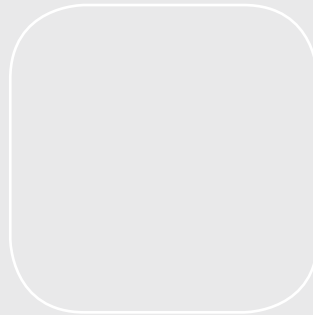



CONTENTS

Standard Specifications	2
Optional Specifications	3
Capacities	4
Towing Capabilities	5
Jacking	6
Wiring Diagrams	7
Bulb Replacement	13
Coachbuilt Body - bulb replacement instructions.....	14

Standard Specifications

Model	Capri Low-Line	Siena Low-Line	Napoli High-Line	Milano High-Line	Roma High-Line	Firenze High-Line
Engine	Fiat '100 MultiJet' diesel	Fiat '100 MultiJet' diesel	Fiat '100 MultiJet' diesel	Fiat '100 MultiJet' diesel	Fiat '130 MultiJet' diesel	Fiat '130 MultiJet' diesel
Engine Capacity	2198cc	2198cc	2198cc	2198cc	2287cc	2287cc
Engine Power	100bhp @ 2900rpm	100bhp @ 2900rpm	100bhp @ 2900rpm	100bhp @ 2900rpm	130bhp @ 3600rpm	130bhp @ 3600rpm
Torque	250Nm @ 1500rpm	250Nm @ 1500rpm	250Nm @ 1500rpm	250Nm @ 1500rpm	320Nm @ 2000rpm	320Nm @ 2000rpm
Chassis	Fiat chassis-cab	Fiat chassis-cab	Fiat chassis-cab	Fiat chassis-cab	Fiat chassis-cab	Fiat chassis-cab
Wheel base	3.00m/9'10"	3.45m/11'4"	3.45m/11'4"	3.45m/11'4"	3.80m/12'6"	4.04m/13'3"
Designated Passenger Seats	1	1	1	3	3	5
Berths (sleeping positions)	2	2	4	5	4	6
Overall Length (no ladder)*	5.75m/18'10"	6.32m/20'9"	6.32m/20'9"	6.32m/20'9"	7.13m/23'5"	7.34m/24'1"
Overall Width (mirrors folded)	2.24m/7'4"	2.24m/7'4"	2.24m/7'4"	2.24m/7'4"	2.24m/7'4"	2.24m/7'4"
Overall Height	2.96m/9'9"	2.96m/9'9"	3.05m/10'0"	3.05m/10'0"	3.05m/10'0"	3.05m/10'0"
Maximum Technical Permissible Laden Mass (A)	3300kg	3500kg	3500kg	3500kg	4005kg	4005kg
Mass in Running Order (B)†	2765kg	2870kg	2960kg	3015kg	3245kg	3345kg
Maximum User Payload (A-B)	535kg	630kg	540kg	485kg	760kg	660kg
Essential Habitation Equipment	10kg	10kg	10kg	10kg	10kg	10kg
Thermal Insulation Grade	(TWO)	(TWO)	(TWO)	(TWO)	(TWO)	(TWO)
Bed Sizes						
Front Double	2.09m x 1.33m/6'10" x 4'4"			1.88m x 1.23m/6'2" x 4'0"		1.88m x 1.23m/6'2" x 4'0"
Front Nearside Single				1.88m x 0.66m/6'2" x 2'2"		
Front Offside Single				1.88m x 0.90m/6'2" x 2'11"		1.88m x 0.90m/6'2" x 2'11"
Rear Double		2.09m x 1.86m/6'10" x 6'1"	2.09m x 1.39m/6'10" x 4'7"		1.93m x 1.32m/6'4" x 4'4"	2.09m x 1.34m/6'10" x 4'5"
Rear Nearside Single		1.87m x 0.68m/6'2" x 2'3"				1.87m x 0.68m/6'2" x 2'3"
Rear Offside Single		1.86m x 0.68m/6'1" x 2'3"				1.86m x 0.68m/6'1" x 2'3"
Overcab Bed			1.91m x 1.37m/6'3" x 4'6"	1.91m x 1.37m/6'3" x 4'6"	1.91m x 1.37m/6'3" x 4'6"	1.91m x 1.37m/6'3" x 4'6"

- NOTE:**
- The **Maximum User Payload** includes:
 - the **conventional load** (this is the allowance for passengers)
 - essential habitation equipment** (items and fluids required for safe and proper functioning of habitation equipment)
 - optional equipment** (items available from the manufacturer over and above the standard specification)
 - personal effects** (those items not covered by the above)
 - The **Mass in Running Order** is the mass of the unladen vehicle including a 75kg allowance for the driver plus engine coolants and 90% of the fuel tank, water tank and gas capacity.
 - PLEASE TAKE CARE TO ENSURE THAT YOU HAVE ALLOWED FOR THE MASSES OF ALL ITEMS YOU INTEND TO CARRY IN THE MOTOR CARAVAN,** e.g. passengers, optional equipment, essential habitation equipment and personal effects, such as clothing, food, pets, bicycles, sailboards, sports equipment etc.
 - WARNING - UNDER NO CIRCUMSTANCES SHOULD THE MAXIMUM TECHNICAL PERMISSIBLE LADEN MASS OF THIS MOTOR CARAVAN BE EXCEEDED.**
 - * For optional roof ladder (add 200mm).

Optional Specifications

Model	Siena Low-Line	Napoli High-Line	Milano High-Line	Roma High-Line	Firenze High-Line
Engine	Fiat '130 MultiJet' diesel	Fiat '130 MultiJet' diesel	Fiat '130 MultiJet' diesel	Fiat '160 MultiJet' diesel	Fiat '160 MultiJet' diesel
Engine Capacity	2287cc	2287cc	2287cc	2999cc	2999cc
Engine Power	130bhp @ 3600rpm	130bhp @ 3600rpm	130bhp @ 3600rpm	157bhp @ 3500rpm	157bhp @ 3500rpm
Torque	320Nm @ 2000rpm	320Nm @ 2000rpm	320Nm @ 2000rpm	400Nm @ 1700rpm	400Nm @ 1700rpm
Chassis	Fiat chassis-cab	Fiat chassis-cab	Fiat chassis-cab	Fiat chassis-cab	Fiat chassis-cab
Wheel base	3.45m/11'4"	3.45m/11'4"	3.45m/11'4"	4.04m/13'3"	4.04m/13'3"
Designated Passenger Seats	1	1	3	5	5
Berths (sleeping positions)	2	4	5	6	6
Overall Length (no ladder)*	6.32m/20'9"	6.32m/20'9"	6.32m/20'9"	7.34m/24'1"	7.34m/24'1"
Overall Width (mirrors folded)	2.24m/7'4"	2.24m/7'4"	2.24m/7'4"	2.24m/7'4"	2.24m/7'4"
Overall Height	2.96m/9'9"	3.05m/10'0"	3.05m/10'0"	3.05m/10'0"	3.05m/10'0"
Maximum Technical Permissible Laden Mass (A)	3500kg	3500kg	3500kg	4005kg	4005kg
Mass in Running Order (B)†	2885kg	2975kg	3030kg	3312kg	3412kg
Maximum User Payload (A-B)	615kg	525kg	470kg	693kg	593kg
Essential Habitation Equipment	10kg	10kg	10kg	10kg	10kg
Thermal Insulation Grade	(TWO)	(TWO)	(TWO)	(TWO)	(TWO)
Bed Sizes					
Front Double			1.88m x 1.23m/6'2" x 4'0"		1.88m x 1.23m/6'2" x 4'0"
Front Nearside Single			1.88m x 0.66m/6'2" x 2'2"		
Front Offside Single			1.88m x 0.90m/6'2" x 2'11"		1.88m x 0.90m/6'2" x 2'11"
Rear Double	2.09m x 1.86m/6'10" x 6'1"	2.09m x 1.39m/6'10" x 4'7"		1.93m x 1.32m/6'4" x 4'4"	2.09m x 1.34m/6'10" x 4'5"
Rear Nearside Single	1.87m x 0.68m/6'2" x 2'3"				1.87m x 0.68m/6'2" x 2'3"
Rear Offside Single	1.86m x 0.68m/6'1" x 2'3"				1.86m x 0.68m/6'1" x 2'3"
Overcab Bed		1.91m x 1.37m/6'3" x 4'6"	1.91m x 1.37m/6'3" x 4'6"	1.91m x 1.37m/6'3" x 4'6"	1.91m x 1.37m/6'3" x 4'6"

- NOTE:**
1. **The Maximum User Payload** includes:
 - a) the **conventional load** (this is the allowance for passengers)
 - b) **essential habitation equipment** (items and fluids required for safe and proper functioning of habitation equipment)
 - c) **optional equipment** (items available from the manufacturer over and above the standard specification)
 - d) **personal effects** (those items not covered by the above)
 2. **The Mass in Running Order** is the mass of the unladen vehicle including a 75kg allowance for the driver plus engine coolants and 90% of the fuel tank, water tank and gas capacity.
 3. **PLEASE TAKE CARE TO ENSURE THAT YOU HAVE ALLOWED FOR THE MASSES OF ALL ITEMS YOU INTEND TO CARRY IN THE MOTOR CARAVAN,**
e.g. passengers, optional equipment, essential habitation equipment and personal effects, such as clothing, food, pets, bicycles, sailboards, sports equipment etc.
 4. **WARNING - UNDER NO CIRCUMSTANCES SHOULD THE MAXIMUM TECHNICAL PERMISSIBLE LADEN MASS OF THIS MOTOR CARAVAN BE EXCEEDED.**
* For optional roof ladder (add 200mm).

Capacities

Water Tank Capacities

	Fresh Water Tank	Waste Water Tank	Water Heater	Toilet Tank (Flushing)
Ace	90 litre	68 litre	10 litre	0 litre

Gas Capacities

	Capacity
Ace	2 x 7kg

The above are recommended gas bottle sizes

NOTICE

For technical data on the base vehicle please refer to manufacturer's handbook

Ace Towing Capabilities

Model	Engine / Chassis	MTPLM	Permissible Front Axle Load	Permissible Rear Axle Load	Recommended Maximum Trailer Weight	Gross Train Weight
Ace Capri	2.2L / SWB / ABS	3300kg	1750kg	1900kg	1175kg	5300kg
Ace Siena	2.2L / MWB / ABS	3500kg	1850kg	2000kg	1105kg	5500kg
Ace Siena	2.3L / MWB / ABS	3500kg	1850kg	2000kg	1380kg	6000kg
Ace Napoli	2.2L / MWB / ABS	3500kg	1850kg	2000kg	1105kg	5500kg
Ace Napoli	2.3L / MWB / ABS	3500kg	1850kg	2000kg	1380kg	6000kg
Ace Milano	2.2L / MWB / ABS	3500kg	1850kg	2000kg	1105kg	5500kg
Ace Milano	2.3L / MWB / ABS	3500kg	1850kg	2000kg	1380kg	6000kg
Ace Roma	2.3L / MLWB / ABS	4005kg	2100kg	2400kg	1085kg	6505kg
Ace Roma	3.0L / MLWB / ABS / AUTO	4005kg	2100kg	2400kg	1085kg	6505kg
Ace Firenze	2.3L / LWB / ABS	4005kg	2100kg	2400kg	1155kg	6505kg
Ace Firenze*	3.0L / LWB / ABS / AUTO	4005kg	2100kg	2400kg	1155kg	6505kg

Please note that the additional weight of the tow bar and trailer nose weight increases the rear axle loading of the motorhome so care should be taken that the rear axle load is not exceeded when towing.

To ensure adequate road holding, the load on the front axle, under all conditions must be not less than 40% or more than 70% of the total weight. Care must be taken when distributing loads. The loadings above are maximum loadings and must not be exceeded under any circumstances.

* With this vehicle configuration it will be necessary to reduce the payload carried inside the van when towing to ensure that the MTPLM and maximum axle loads are not exceeded.

CAUTION: When fitting a towbar, it must meet certain minimum requirements as specified by Type Approval Regulations. The bar will have marked on it the approval standard (94/20/EC) and the maximum download, or noseweight, that it can accept. It must fit the manufacturer's approved mounting points and must not obscure the towing vehicle's number plate.

Jacking

ACE

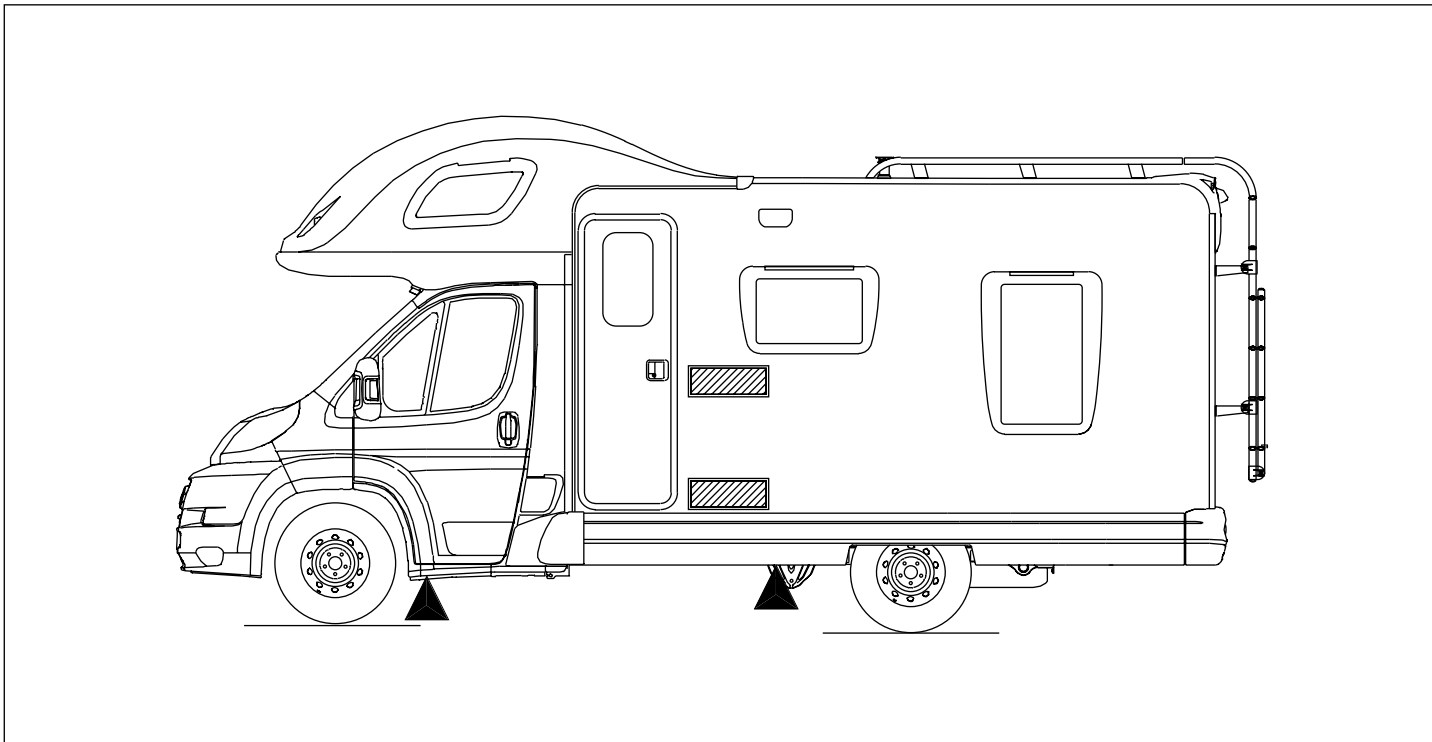

Jacking Points for High-Line and Low-Line: ▲

ROAD LIGHTING

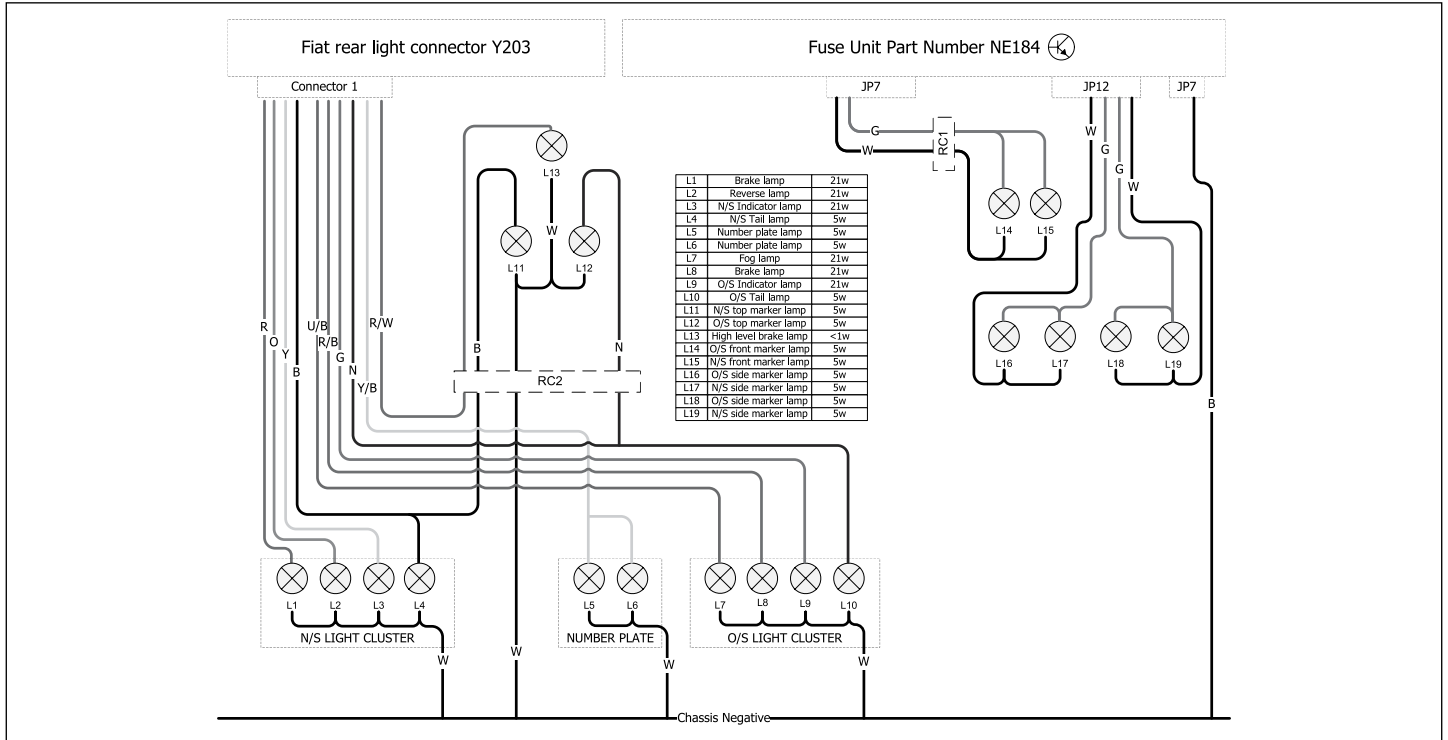

Wiring Diagrams

CONSUMER CIRCUITS – ROOF

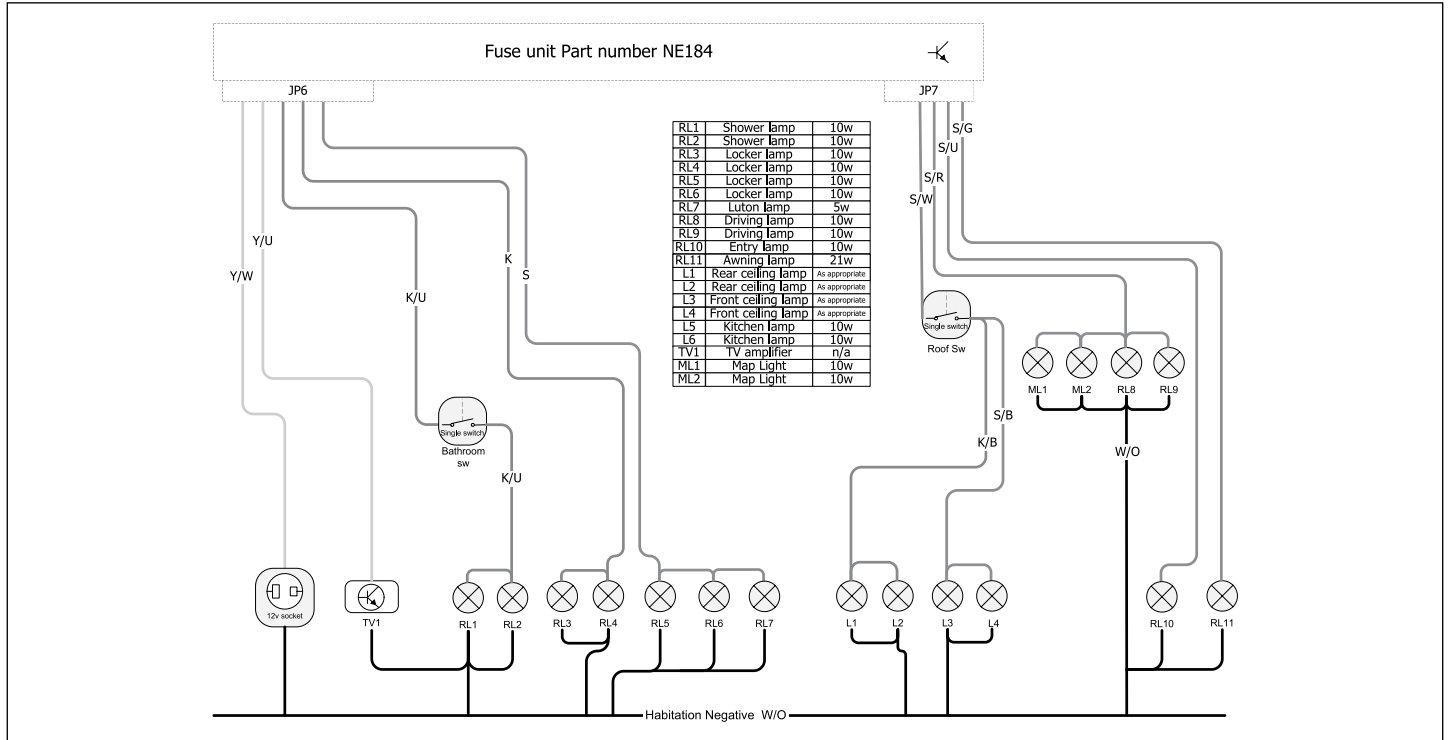

POWER CIRCUITS

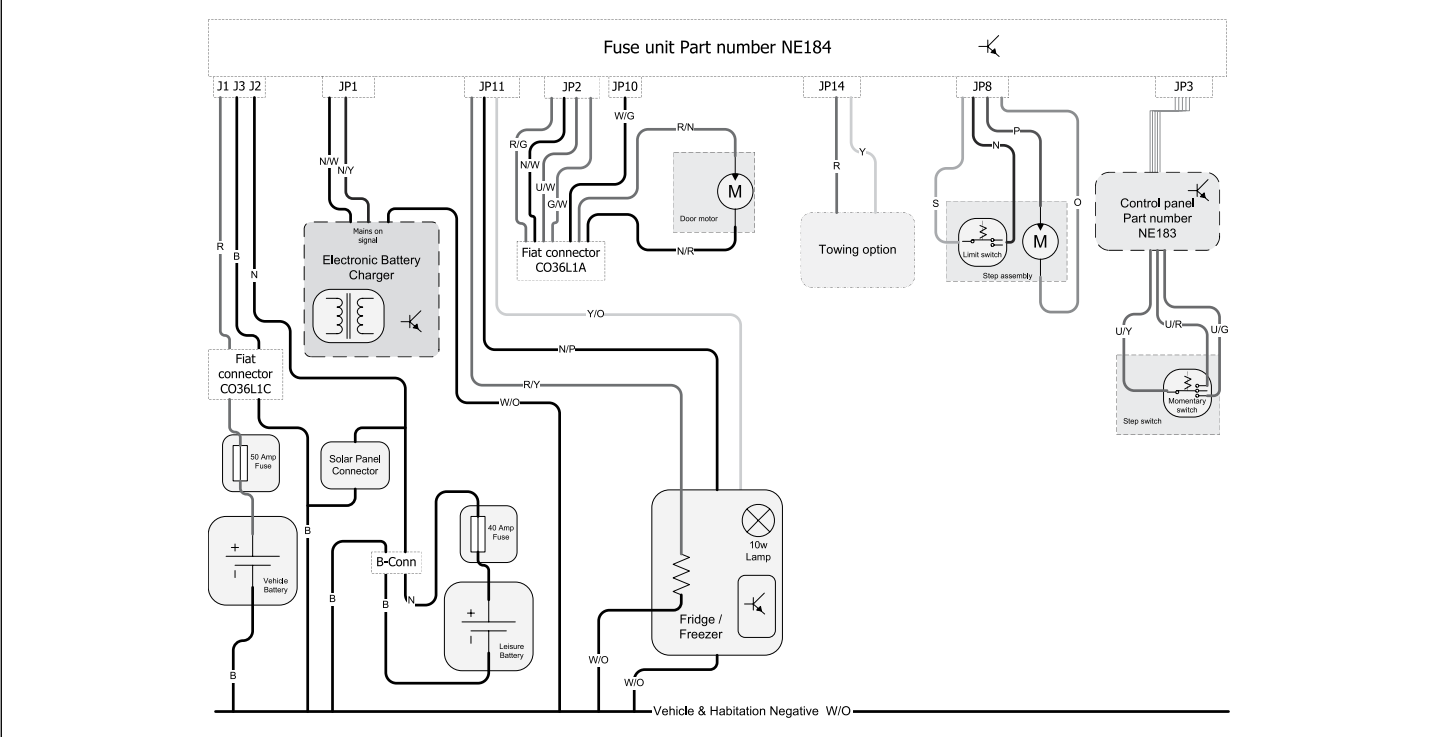

230V CIRCUITS

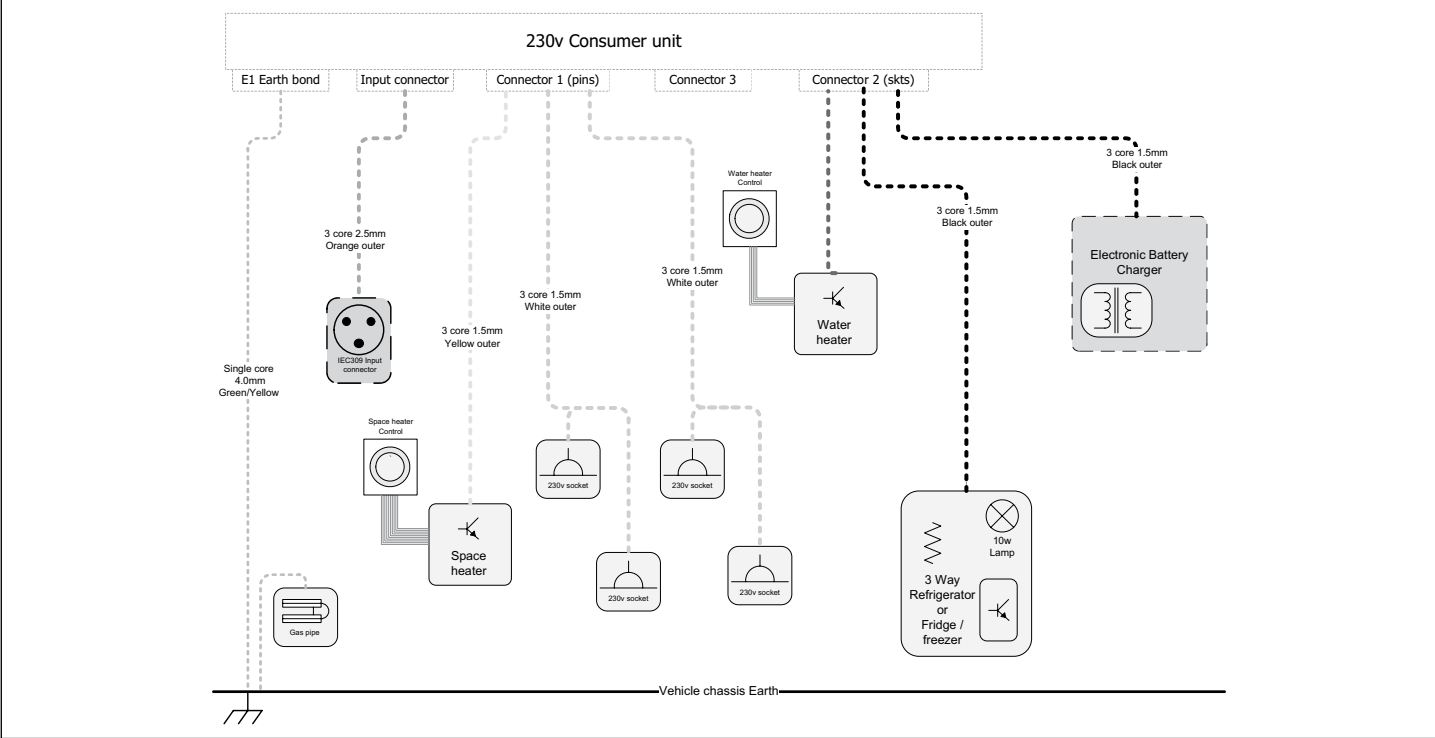

CABLE COLOUR CHART



12v Cable Colours

B	BLACK
N	BROWN
R	RED
O	ORANGE
Y	YELLOW
G	GREEN
U	BLUE
P	PURPLE
S	SLATE GREY
W	WHITE
K	PINK

230v Cable Colours

B	BLACK
N	BROWN
W	WHITE
O	ORANGE
Y	YELLOW
G	GREEN
U	BLUE

Bulb Replacement

Road Lights		
Application	Bulb Reference	Bulb Rating
Front marker light	W5W	12v 5w
Front marker light	LED - Replace lamp	12v <1w
Side marker light	W5W	12v 5w
Rear high level marker light	W5W	12v 5w
Rear high level marker light	LED - Replace lamp	12v <1w
High level stop lamp	T5/13.5	12v 2.3w
Rear indicator lamp	PY21 Orange	12v 21w
Rear Tail lamp	LED - Replace lamp	12v 1.2w
Rear Stop lamp	P21	12v 21w
Rear Stop / Tail lamp	P21/5W	12v 21w / 5w
Rear reverse lamp	P21	12v 21w
Rear fog lamp	P21	12v 21w
Number plate light	C5W	12v 5w
Interior / Other		
Downlighters	Halogen capsule	G4 12v 10w
Locker down lights	GU4/MR11 Dichroic	GU4 12v 10w
Locker Spotlights	GU5.3/MR16 Dichroic	GU5.312v 10w
Cooker hood mounted lamps	GU4/MR11 Dichroic	GU4 12v 10w
Panel mounted fluorescent lamps	300mm Fluorescent	12v 8w
Panel mounted fluorescent lamps	600mm Fluorescent	12v 13w
Ceiling lights	Halogen capsule	G4 10w
Luton Fluorescent lamps	300mm Fluorescent	12v 8w
B-pillar map reading lamps	GU4/MR11 Dichroic	GU4 12v 10w
Awning lamp	P21W	12v 21w

Bulb Replacement

COACHBUILT BODY MOUNTED LAMPS - REPLACEMENT INSTRUCTIONS

STOP / TAIL, INDICATOR, FOG AND REVERSE LAMPS

Bulb access is from front / via lense of each lamp

Remove 2x screws from each light lense and withdraw lense

Bulbs are a bayonet fitting – apply slight pressure on bulb towards light fitting, and twist to release

Reverse procedure to re-fit bulb and lense.

Take care when replacing stop/tail lamp bulb, that orientation of bulb is correct – to check, brake light operation should be brighter than tail lamp operation.

UPPER MARKER / POSITION LAMPS

Bulb access is from rear of lamp

Remove 2x screws from light fitting, and withdraw whole fitting from motorhome body

Harness plugs into bulb holder – Twist bulb holder relative to lamp body to release bulb holder from lamp body

Bulbs are push fit into bulb holder – pull bulb directly away from holder to release

Reverse procedure to replace bulb in holder, holder in lamp and lamp onto motorhome body

HIGH LEVEL BRAKE LAMP

Light is one piece design with no internally replaceable parts

Remove 2x screws at either end of lamp, and withdraw whole fitting away from motorhome body

Harness connects via a connector with retention barb into the rear of the lamp. With finger pressure or using a small screwdriver release the barb by pushing it toward the harness, and unplug the harness from the lamp

Push fit connector back into replacement lamp, and secure lamp to motorhome body with 2x screws

Lamp retaining screws are fixed into a rubber sleeve with a threaded insert, often known as a rawlnut. If lamp has been removed / re-fitted several times the rubber sleeve may need replacing, these are available through your dealer

SIDE MARKER / POSITION LAMPS

Bulb access is from rear of lamp

Check first within motorhome if rear of lamp is visible

If rear of lamp is visible:

Harness plugs into bulb holder – Twist bulb holder relative to lamp body to release bulb holder from lamp body

Bulbs are push fit into bulb holder – pull bulb directly away from holder to release

Reverse procedure to replace bulb in holder, holder in lamp and lamp onto motorhome body

If rear of lamp is not visible:

Remove 2x screws from light fitting, and withdraw whole fitting from motorhome body

Harness plugs into bulb holder – Twist bulb holder relative to lamp body to release bulb holder from lamp body

Bulbs are push fit into bulb holder – pull bulb directly away from holder to release

Reverse procedure to replace bulb in holder, holder in lamp and lamp onto motorhome body

