



Individually styled
Beautifully built

BESSACARR MOTORHOMES

Dunswell Road, Cottingham, East Yorkshire HU16 4JX.

Tel: 01482 875740 Fax: 01482 840082

email: enquiry@swiftleisure.co.uk

website: www.bessacarrmotorhomes.co.uk

A MEMBER OF THE SWIFT GROUP

1079251 issued October 2007

bessacarrmotorhomes

E600 Series specification, wiring diagrams & bulb chart





CONTENTS

Standard Specifications.....	2
Optional Specifications.....	3
Capacities	4
Towing Capabilities	5
Jacking.....	6
Wiring Diagrams.....	7
Bulb Replacement	13

Standard Specifications

MODEL	Bessacarr E635	Bessacarr E665	Bessacarr E695
Engine	Fiat '130 MultiJet' diesel	Fiat '130 MultiJet' diesel	Fiat '130 MultiJet' diesel
Engine Capacity	2287cc	2287cc	2287cc
Engine Power	130bhp @ 3600rpm	130bhp @ 3600rpm	130bhp @ 3600rpm
Engine Torque	320Nm @ 2000rpm	320Nm @ 2000rpm	320Nm @ 2000rpm
Chassis	Fiat Maxi Chassis Cab	Fiat Maxi Chassis Cab	Fiat Maxi Chassis Cab
Wheel base	3.45m/11'4"	4.04m/13'3"	4.04m/13'3"
Designated Passenger Seats	5	3	3
Berths (sleeping positions)	5	4	4
Overall Length (no ladder)*	6.58m/21'7"	7.08m/23'3"	7.08m/23'3"
Overall Width (mirrors folded)	2.35m/7'8"	2.35m/7'8"	2.35m/7'8"
Overall Height (inc. TV aerial)	3.05m/10'0"	3.05m/10'0"	3.05m/10'0"
Maximum Technical Permissible Laden Mass (A)	4005kg	4005kg	4005kg
Mass in Running Order (B)	3260kg	3360kg	3370kg
Maximum User Payload (A-B)	745kg	645kg	635kg
Essential Habitation Equipment	10kg	10kg	10kg
Maximum recommended trailer weight	1200kg	1250kg	1250kg
Thermal Insulation Grade	Three	Three	Three
BED SIZES			
Front Double	1.85m x 1.30m/6'1" x 4'3"		
Front Nearside Single	1.85m x 0.97m/6'1" x 3'2"		
Front Offside Single	1.82m x 0.71m/6'0" x 2'4"		
Rear Double		1.90m x 1.31m/6'3" x 4'4"	2.11m x 1.77m/6'11" x 5'10"
Rear Nearside Single			1.77m x 0.70m/5'10" x 2'4"
Rear Offside Single			1.89m x 0.70m/6'2" x 2'4"
Overcab Bed	1.91m x 1.37m/6'3" x 4'6"	1.91m x 1.37m/6'3" x 4'6"	1.91m x 1.37m/6'3" x 4'6"

- NOTE:** 1. The **Maximum User Payload** includes: a) the **conventional load** (this is the allowance for passengers)
b) **essential habitation equipment** (items and fluids required for safe and proper functioning of habitation equipment)
c) **optional equipment** (items available from the manufacturer over and above the standard specification)
d) **personal effects** (those items not covered by the above)
2. The **Mass in Running Order** is the mass of the unladen vehicle including a 75kg allowance for the driver plus engine coolants and 90% of the fuel tank, water tank and gas capacity.
3. PLEASE TAKE CARE TO ENSURE THAT YOU HAVE ALLOWED FOR THE MASSES OF ALL ITEMS YOU INTEND TO CARRY IN THE MOTOR CARAVAN, e.g. passengers, optional equipment, essential habitation equipment and personal effects, such as clothing, food, pets, bicycles, sailboards, sports equipment etc.
4. **WARNING** - UNDER NO CIRCUMSTANCES SHOULD THE MAXIMUM TECHNICAL PERMISSIBLE LADEN MASS OF THIS MOTOR CARAVAN BE EXCEEDED.

* For optional roof ladder (add 125mm)

Optional Specifications

MODEL	Bessacarr E635	Bessacarr E665	Bessacarr E695
Engine	Fiat '160 Auto MultiJet' power diesel	Fiat '160 Auto MultiJet' power diesel	Fiat '160 Auto MultiJet' power diesel
Engine Capacity	2999cc	2999cc	2999cc
Engine Power	157bhp @ 3500rpm	157bhp @ 3500rpm	157bhp @ 3500rpm
Engine Torque	400Nm @ 1700rpm	400Nm @ 1700rpm	400Nm @ 1700rpm
Chassis	Fiat Maxi Chassis Cab	Fiat Maxi Chassis Cab	Fiat Maxi Chassis Cab
Wheel base	3.45m/11'4"	4.04m/13'3"	4.04m/13'3"
Designated Passenger Seats	5	3	3
Berths (sleeping positions)	5	4	4
Overall Length (no ladder)*	6.58m/21'7"	7.08m/23'3"	7.08m/23'3"
Overall Width (mirrors folded)	2.35m/7'8"	2.35m/7'8"	2.35m/7'8"
Overall Height (inc. TV aerial)	3.05m/10'0"	3.05m/10'0"	3.05m/10'0"
Maximum Technical Permissible Laden Mass (A)	4005kg	4005kg	4005kg
Mass in Running Order (B)	3327kg	3427kg	3437kg
Maximum User Payload (A-B)	678kg	578kg	568kg
Essential Habitation Equipment	10kg	10kg	10kg
Maximum recommended trailer weight	1200kg	1250kg	1250kg
Thermal Insulation Grade	Three	Three	Three
BED SIZES			
Front Double	1.85m x 1.30m/6'1" x 4'3"		
Front Nearside Single	1.85m x 0.97m/6'1" x 3'2"		
Front Offside Single	1.82m x 0.71m/6'0" x 2'4"		
Rear Double		1.90m x 1.31m/6'3" x 4'4"	2.11m x 1.77m/6'11" x 5'10"
Rear Nearside Single			1.77m x 0.70m/5'10" x 2'4"
Rear Offside Single			1.89m x 0.70m/6'2" x 2'4"
Overcab Bed	1.91m x 1.37m/6'3" x 4'6"	1.91m x 1.37m/6'3" x 4'6"	1.91m x 1.37m/6'3" x 4'6"

- NOTE:** 1. The **Maximum User Payload** includes: a) the **conventional load** (this is the allowance for passengers)
b) **essential habitation equipment** (items and fluids required for safe and proper functioning of habitation equipment)
c) **optional equipment** (items available from the manufacturer over and above the standard specification)
d) **personal effects** (those items not covered by the above)
2. The **Mass in Running Order** is the mass of the unladen vehicle including a 75kg allowance for the driver plus engine coolants and 90% of the fuel tank, water tank and gas capacity.
3. PLEASE TAKE CARE TO ENSURE THAT YOU HAVE ALLOWED FOR THE MASSES OF ALL ITEMS YOU INTEND TO CARRY IN THE MOTOR CARAVAN,
e.g. passengers, optional equipment, essential habitation equipment and personal effects, such as clothing, food, pets, bicycles, sailboards, sports equipment etc.
4. **WARNING** - UNDER NO CIRCUMSTANCES SHOULD THE MAXIMUM TECHNICAL PERMISSIBLE LADEN MASS OF THIS MOTOR CARAVAN BE EXCEEDED.

* For optional roof ladder (add 125mm)

Note: Rear double bed sizes quoted on E695 with wrap round seating

Capacities

Water Tank Capacities

	Fresh Water Tank	Waste Water Tank	Water Heater	Toilet Tank (Flushing)
Bessacarr E600	90 litre	68 litre	10 litre	0 litre

Gas Capacities

	Capacity
Bessacarr E600	2 x 7kg

The above are recommended gas bottle sizes

NOTICE

For technical data on the base vehicle please refer to manufacturer's handbook

Towing Capabilities

E600 Towing Capabilities

Model	Engine / Chassis	MTPLM	Permissible Front Axle Load	Permissible Rear Axle Load	Recommended Maximum Trailer Weight	Gross Train Weight
Bessacarr E635	2.3L / MWB / ABS	4005kg	2100kg	2400kg	1200kg	6505kg
Bessacarr E635	3.0L / MWB / ABS / AUTO	4005kg	2100kg	2400kg	1200kg	6505kg
Bessacarr E665	2.3L / LWB / ABS	4005kg	2100kg	2400kg	1250kg	6505kg
Bessacarr E665	3.0L / LWB / ABS / AUTO	4005kg	2100kg	2400kg	1250kg	6505kg
Bessacarr E695	2.3L / LWB / ABS	4005kg	2100kg	2400kg	1250kg	6505kg
Bessacarr E695	3.0L / LWB / ABS / AUTO	4005kg	2100kg	2400kg	1250kg	6505kg

To ensure adequate road holding, the load on the front axle, under all conditions, must not be less than 40% or more than 70% of the total weight.

Care must be taken when distributing loads. The loadings above are maximum loadings and must not be exceeded under any circumstances.

CAUTION: When fitting a towbar, it must meet certain minimum requirements as specified by Type Approval Regulations. The bar will have marked on it the approval standard (94/20/EC) and the maximum download, or noseweight, that it can accept. It must fit the manufacturer's approved mounting points and must not obscure the towing vehicle's number plate.

Jacking

BESSACARR E600

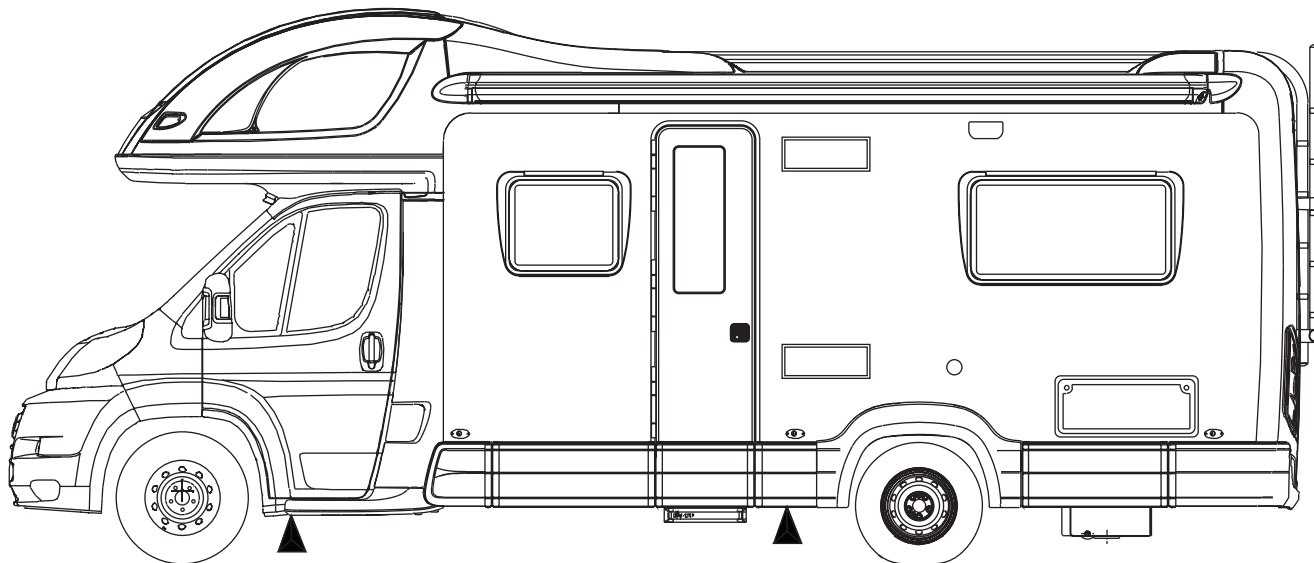

Jacking Points: ▲

BESSACARR E600 SERIES - 230V CIRCUITS

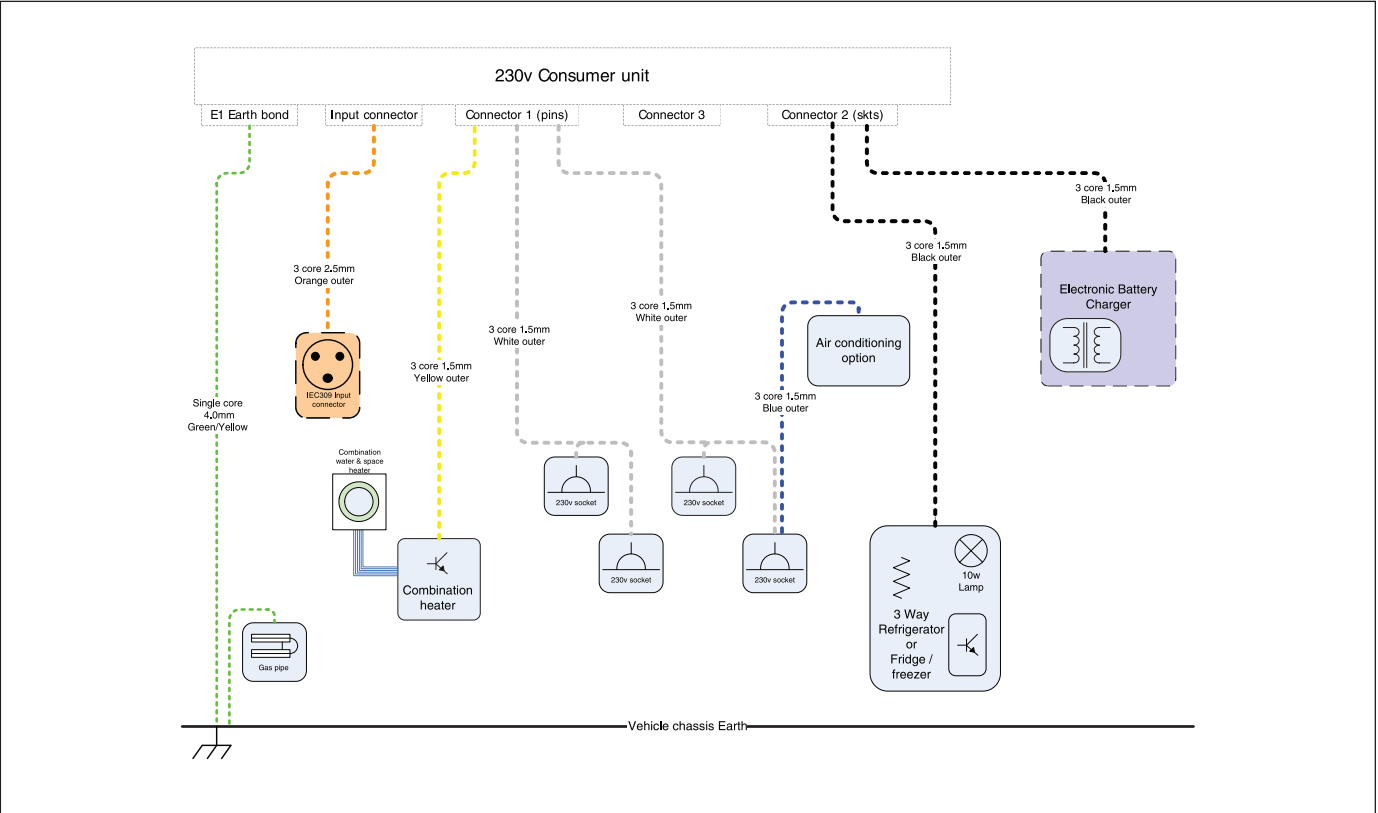

Wiring Diagrams

BESSACARR E600 SERIES - POWER CIRCUITS

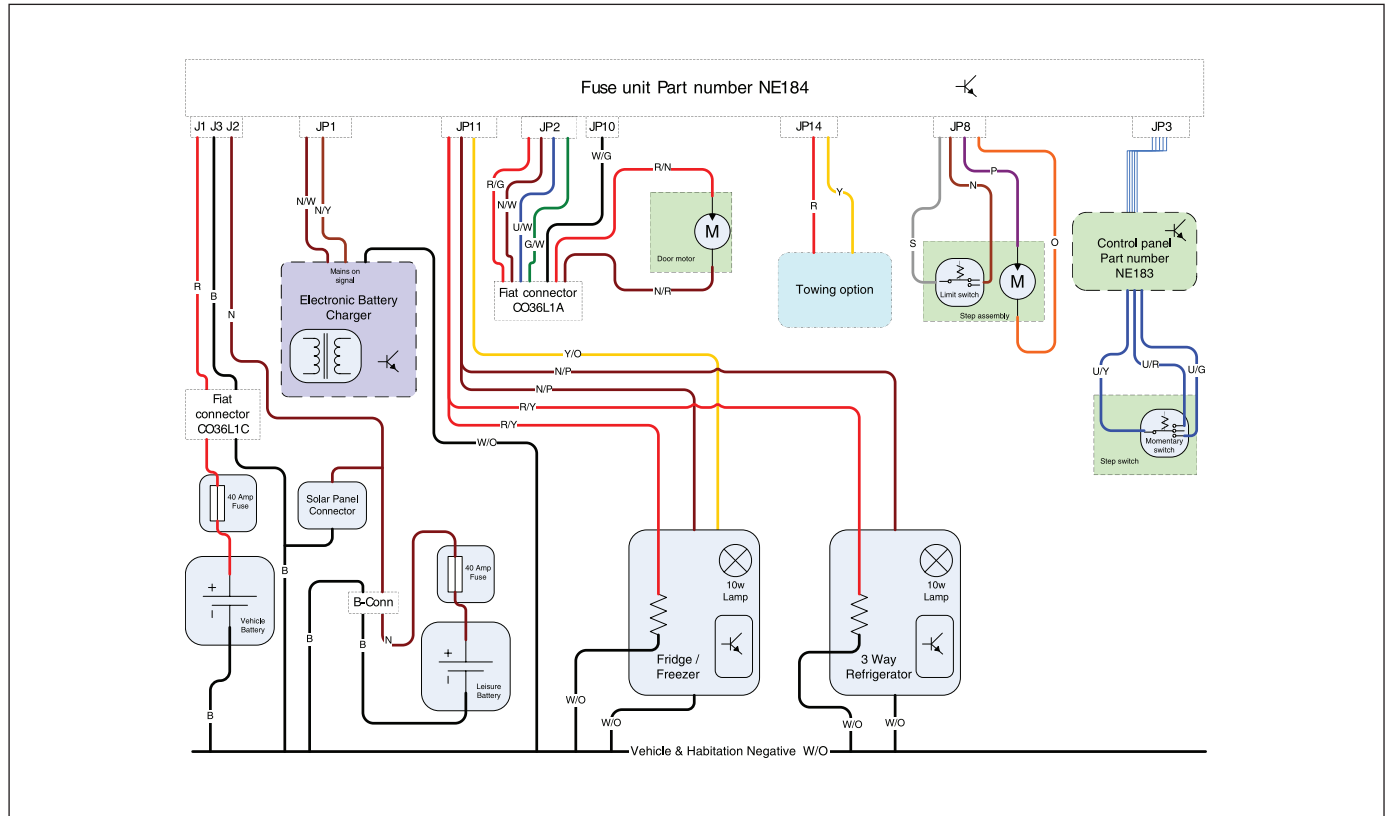

BESSACARR E600 SERIES - CONSUMER CIRCUITS – FLOOR

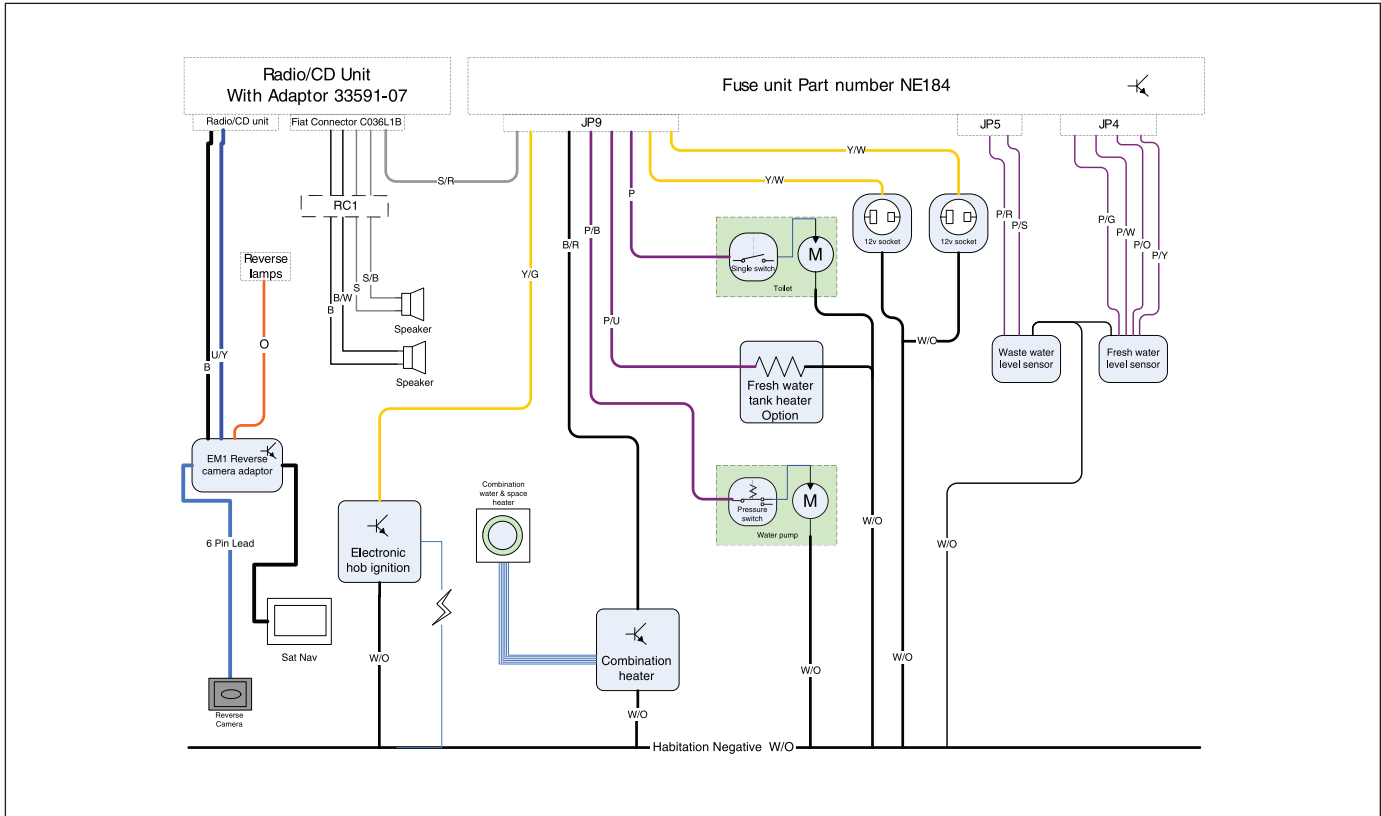

Wiring Diagrams

BESSACARR E600 SERIES - CONSUMER CIRCUITS - ROOF

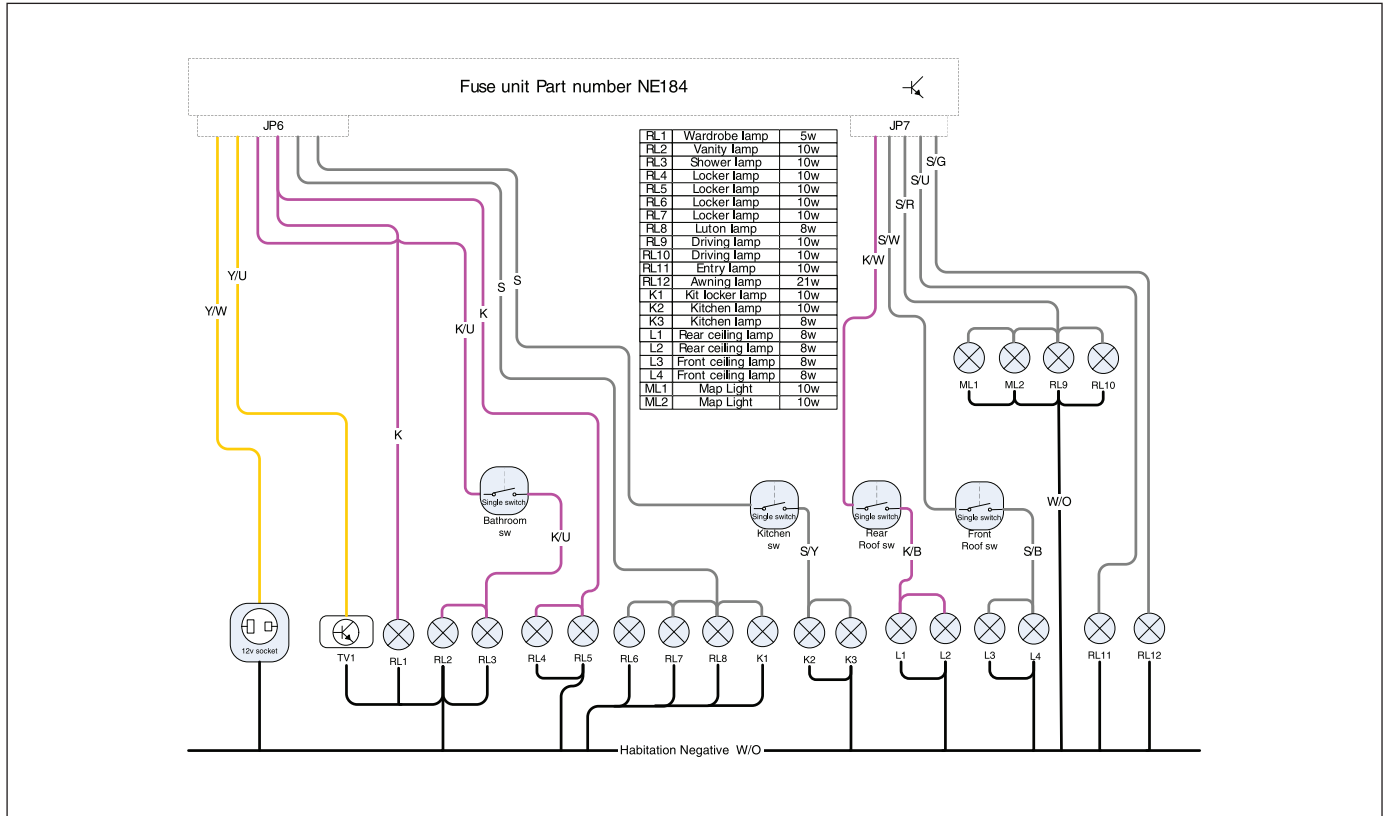

BESSACARR E600 SERIES - ROAD LIGHTING

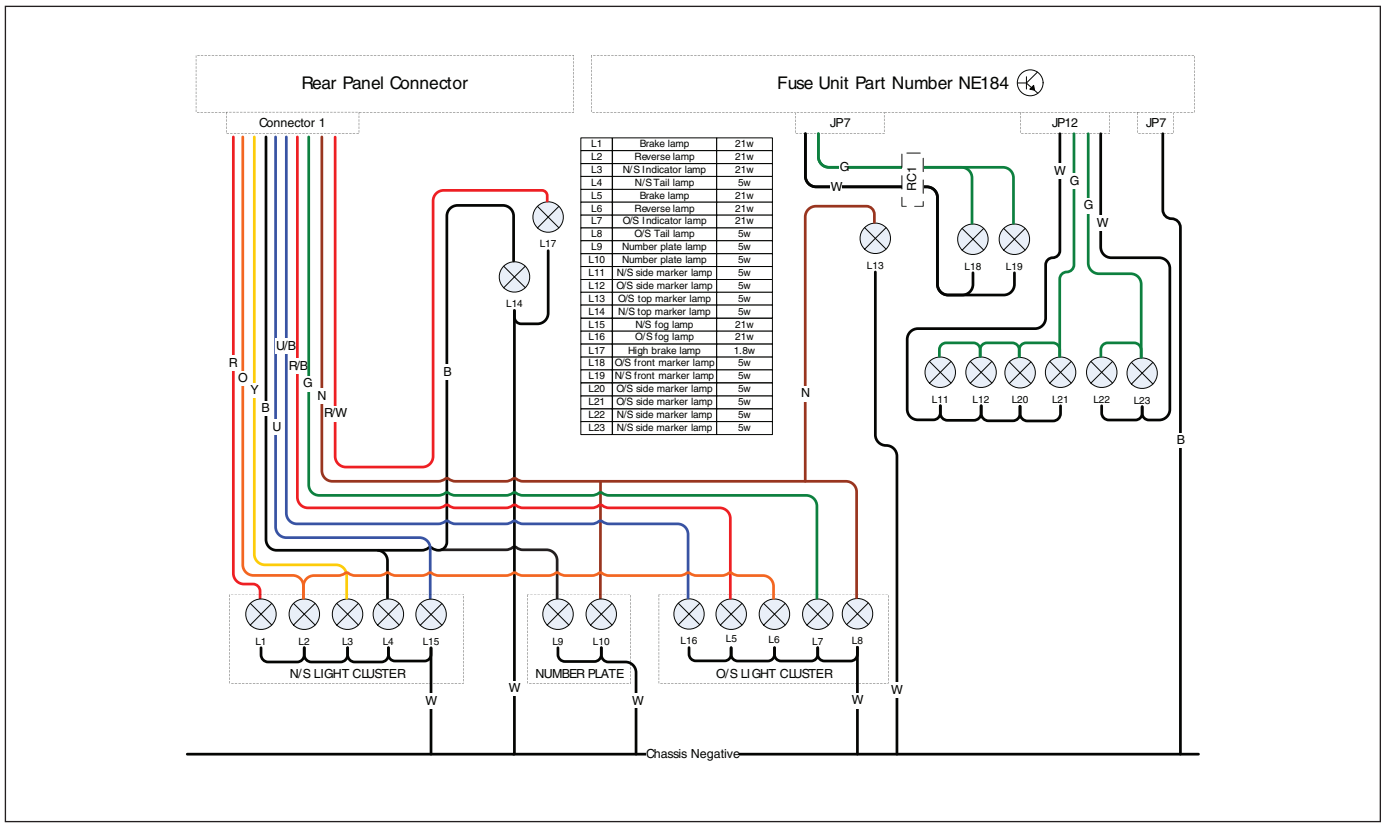

Wiring Diagrams

BESSACARR E600 SERIES - CABLE COLOUR CHART



12v Cable Colours

B	BLACK
N	BROWN
R	RED
O	ORANGE
Y	YELLOW
G	GREEN
U	BLUE
P	PURPLE
S	SLATE GREY
W	WHITE
K	PINK

230v Cable Colours

B	BLACK
N	BROWN
W	WHITE
O	ORANGE
Y	YELLOW
G	GREEN
U	BLUE

Bulb Replacement

BESSACARR E600				
	Bulb Reference	Bulb Rating		
EXTERIOR LIGHTS				
Front marker light	W5W	12V 5W		
Side marker light	W5W	12V 5W		
Rear high level marker light	W5W	12V 5W		
High level stop lamp	T5/13.5	12V 2.3W		
Rear indicator lamp	PY21 Orange	12V 21W		
Rear stop / Tail lamp	PY21/5W	12V 21W / 5W		
Rear reverse lamp	P21	12V 21W		
Rear fog lamp	P21	12V 21W		
Number plate light	C5W	12V 5W		
INTERIOR LIGHTS				
Downlighters	Halogen capsule	G4 12V 10W		
Locker spotlights	GU4 / MR11 Dichroic	GU4 12V 10W		
Toilet/Kitchen locker light	600mm Fluorescent	12V 13W		
Panel mounted fluorescent lamps	300mm Fluorescent	12V 13W		
Skylight surround fluorescent lamps	300mm Fluorescent	12V 8W		
B Pillar map reading lamps	GU4 / MR11 Dichroic	GU4 12V 10W		
Awning lamp	P21W	12V 21W		

Note: Not all lights and bulbs feature on all models within a range