



Quality with Style

Swift Motorhomes

Dunswell Road, Cottingham, East Yorkshire HU16 4JX.

Tel: 01482 875740 Fax: 01482 840082

email: enquiry@swiftleisure.co.uk

web site: www.swiftmotorhomes.co.uk

A MEMBER OF THE SWIFT GROUP

1076321 v2 issued November 2006



Swift

Specification, wiring diagrams & bulb chart

Sundance





CONTENTS

Standard Specifications.....	2
Optional Specifications.....	3
Capacities	4
Towing Capabilities	5
Jacking.....	6
Wiring Diagrams.....	7
Bulb Replacement	11

Standard Specifications

MODEL	530LP Low-Line	580PR Low-Line	590RL High-Line	590RS High-Line	630G High-Line	630L High-Line
Engine	Fiat '100 MultiJet' diesel	Fiat '100 MultiJet' diesel	Fiat '100 MultiJet' diesel	Fiat '100 MultiJet' diesel	Fiat '130 MultiJet' diesel	Fiat '130 MultiJet' diesel
Engine Capacity	2198cc	2198cc	2198cc	2198cc	2287cc	2287cc
Engine Power	100bhp @ 2900rpm	100bhp @ 2900rpm	100bhp @ 2900rpm	100bhp @ 2900rpm	130bhp @ 3600rpm	130bhp @ 3600rpm
Engine Torque	250Nm @ 1500rpm	250Nm @ 1500rpm	250Nm @ 1500rpm	250Nm @ 1500rpm	320Nm @ 2000rpm	320Nm @ 2000rpm
Chassis	Fiat chassis-cab	Fiat chassis-cab	Fiat chassis-cab	Fiat chassis-cab	Fiat chassis-cab	Fiat chassis-cab
Wheel base	3.00m/9'10"	3.45m/11'4"	3.45m/11'4"	3.45m/11'4"	3.80m/12'6"	4.04m/13'3"
Designated Passenger Seats	1	1	1	3	3	5
Berths (sleeping positions)	2	2	4	5	4	6
Overall Length (no ladder)*	5.75m/18'10"	6.32m/20'9"	6.32m/20'9"	6.32m/20'9"	7.13m/23'5"	7.34m/24'1"
Overall Width (mirrors folded)	2.24m/7'4"	2.24m/7'4"	2.24m/7'4"	2.24m/7'4"	2.24m/7'4"	2.24m/7'4"
Overall Height	2.96m/9'9"	2.96m/9'9"	3.05m/10'0"	3.05m/10'0"	3.05m/10'0"	3.05m/10'0"
Maximum Technical Permissible Laden Mass (A)	3000kg	3500kg	3500kg	3500kg	4005kg	4005kg
Mass in Running Order (B)†	2780kg	2885kg	2950kg	3010kg	3245kg	3360kg**
Maximum User Payload (A-B)	220kg	615kg	550kg	490kg	760kg	645kg**
Essential Habitation Equipment	10kg	10kg	10kg	10kg	10kg	10kg
Maximum Recommended Trailer Weight	Not recommended	1070kg	1070kg	1070kg	1050kg	1120kg**
BED SIZES						
Front Double	2.09m x 1.33m/6'10" x 4'4"			1.88m x 1.23m/6'2" x 4'0"		1.88m x 1.23m/6'2" x 4'0"
Front Nearside Single				1.88m x 0.66m/6'2" x 2'2"		
Front Offside Single				1.88m x 0.90m/6'2" x 2'11"		
Rear Double	2.09m x 1.86m/6'10" x 6'1"		2.09m x 1.39m/6'10" x 4'7"	1.93m x 1.32m/6'4" x 4'4"		2.09m x 1.86m/6'10" x 6'1"
Rear Nearside Single	1.87m x 0.68m/6'2" x 2'3"					1.87m x 0.68m/6'2" x 2'3"
Rear Offside Single	1.86m x 0.68m/6'1" x 2'3"					1.86m x 0.68m/6'1" x 2'3"
Overcab Bed			1.91m x 1.37m/6'3" x 4'6"	1.91m x 1.37m/6'3" x 4'6"	1.91m x 1.37m/6'3" x 4'6"	1.91m x 1.37m/6'3" x 4'6"

- NOTE:** 1. The **Maximum User Payload** includes: a) the **conventional load** (this is the allowance for passengers)
b) **essential habitation equipment** (items and fluids required for safe and proper functioning of habitation equipment)
c) **optional equipment** (items available from the manufacturer over and above the standard specification)
d) **personal effects** (those items not covered by the above)
2. The **Mass in Running Order** is the mass of the unladen vehicle including a 75kg allowance for the driver plus engine coolants and 90% of the fuel tank, water tank and gas capacity.
3. PLEASE TAKE CARE TO ENSURE THAT YOU HAVE ALLOWED FOR THE MASSES OF ALL ITEMS YOU INTEND TO CARRY IN THE MOTOR CARAVAN, e.g. passengers, optional equipment, essential habitation equipment and personal effects, such as clothing, food, pets, bicycles, sailboards, sports equipment etc.
4. **WARNING** - UNDER NO CIRCUMSTANCES SHOULD THE MAXIMUM TECHNICAL PERMISSIBLE LADEN MASS OF THIS MOTOR CARAVAN BE EXCEEDED.

* For optional roof ladder (add 200mm).

** Estimated.

Optional Specifications

MODEL	580PR Low-Line	590RL High-Line	590RS High-Line
Engine	Fiat '130 MultiJet' diesel	Fiat '130 MultiJet' diesel	Fiat '130 MultiJet' diesel
Engine Capacity	2287cc	2287cc	2287cc
Engine Power	130bhp @ 3600rpm	130bhp @ 3600rpm	130bhp @ 3600rpm
Engine Torque	320Nm @ 2000rpm	320Nm @ 2000rpm	320Nm @ 2000rpm
Chassis	Fiat chassis-cab	Fiat chassis-cab	Fiat chassis-cab
Wheel base	3.45m/11'4"	3.45m/11'4"	3.45m/11'4"
Designated Passenger Seats	1	1	3
Berths (sleeping positions)	2	4	5
Overall Length (no ladder)*	6.32m/20'9"	6.32m/20'9"	6.32m/20'9"
Overall Width (mirrors folded)	2.24m/7'4"	2.24m/7'4"	2.24m/7'4"
Overall Height	2.96m/9'9"	3.05m/10'0"	3.05m/10'0"
Maximum Technical Permissible Laden Mass (A)	3500kg	3500kg	3500kg
Mass in Running Order (B)†	2900kg	2965kg	3025kg
Maximum User Payload (A-B)	600kg	535kg	475kg
Essential Habitation Equipment	10kg	10kg	10kg
Maximum Recommended Trailer Weight	1070kg	1070kg	1070kg
BED SIZES			
Front Double			1.88m x 1.23m/6'2" x 4'0"
Front Nearside Single			1.88m x 0.66m/6'2" x 2'2"
Front Offside Single			1.88m x 0.90m/6'2" x 2'11"
Rear Double	2.09m x 1.86m/6'10" x 6'1"	2.09m x 1.39m/6'10" x 4'7"	
Rear Nearside Single	1.87m x 0.68m/6'2" x 2'3"		
Rear Offside Single	1.86m x 0.68m/6'1" x 2'3"		
Overcab Bed		1.91m x 1.37m/6'3" x 4'6"	1.91m x 1.37m/6'3" x 4'6"

- NOTE:** 1. The **Maximum User Payload** includes: a) the **conventional load** (this is the allowance for passengers)
b) **essential habitation equipment** (items and fluids required for safe and proper functioning of habitation equipment)
c) **optional equipment** (items available from the manufacturer over and above the standard specification)
d) **personal effects** (those items not covered by the above)
2. The **Mass in Running Order** is the mass of the unladen vehicle including a 75kg allowance for the driver plus engine coolants and 90% of the fuel tank, water tank and gas capacity.
3. PLEASE TAKE CARE TO ENSURE THAT YOU HAVE ALLOWED FOR THE MASSES OF ALL ITEMS YOU INTEND TO CARRY IN THE MOTOR CARAVAN, e.g. passengers, optional equipment, essential habitation equipment and personal effects, such as clothing, food, pets, bicycles, sailboards, sports equipment etc.
4. **WARNING** - UNDER NO CIRCUMSTANCES SHOULD THE MAXIMUM TECHNICAL PERMISSIBLE LADEN MASS OF THIS MOTOR CARAVAN BE EXCEEDED.
- * For optional roof ladder (add 200mm).

Capacities

Water Tank Capacities

	Fresh Water Tank	Waste Water Tank	Water Heater	Toilet Tank (Flushing)
Swift Sundance	90 litre	68 litre	10 litre	0 litre

Gas Capacities

	Capacity
Swift Sundance	2 x 7kg

The above are recommended gas bottle sizes

NOTICE

For technical data on the base vehicle please refer to manufacturer's handbook

Swift Sundance Towing Capabilities

Model	Engine / Chassis	MTPLM	Permissible Front Axle Load	Permissible Rear Axle Load	Recommended Maximum Trailer Weight	Gross Train Weight
Swift Sundance 530LP	2.2L / SWB / ABS	3000kg	1600kg	1650kg	Not Recommended	5000kg
Swift Sundance 580PR	2.2L / MWB / ABS	3500kg	1850kg	2000kg	1070kg	5500kg
Swift Sundance 580PR	2.3L / MWB / ABS	3500kg	1850kg	2000kg	1340kg	6000kg
Swift Sundance 590RL	2.2L / MWB / ABS	3500kg	1850kg	2000kg	1070kg	5500kg
Swift Sundance 590RL	2.3L / MWB / ABS	3500kg	1850kg	2000kg	1340kg	6000kg
Swift Sundance 590RS	2.2L / MWB / ABS	3500kg	1850kg	2000kg	1070kg	5500kg
Swift Sundance 590RS	2.3L / MWB / ABS	3500kg	1850kg	2000kg	1340kg	6000kg
Swift Sundance 630G	2.3L / MLWB / ABS	4005kg	2100kg	2400kg	1050kg	6505kg
Swift Sundance 630L	2.3L / LWB / ABS	4005kg	2100kg	2400kg	1120kg**	6505kg

To ensure adequate road holding, the load on the front axle, under all conditions, must not be less than 40% or more than 70% of the total weight.

Care must be taken when distributing loads. The loadings above are maximum loadings and must not be exceeded under any circumstances.

** Estimated

CAUTION: When fitting a towbar, it must meet certain minimum requirements as specified by Type Approval Regulations. The bar will have marked on it the approval standard (94/20/EC) and the maximum download, or noseweight, that it can accept. It must fit the manufacturer's approved mounting points and must not obscure the towing vehicle's number plate.

Jacking

SWIFT SUNDANCE

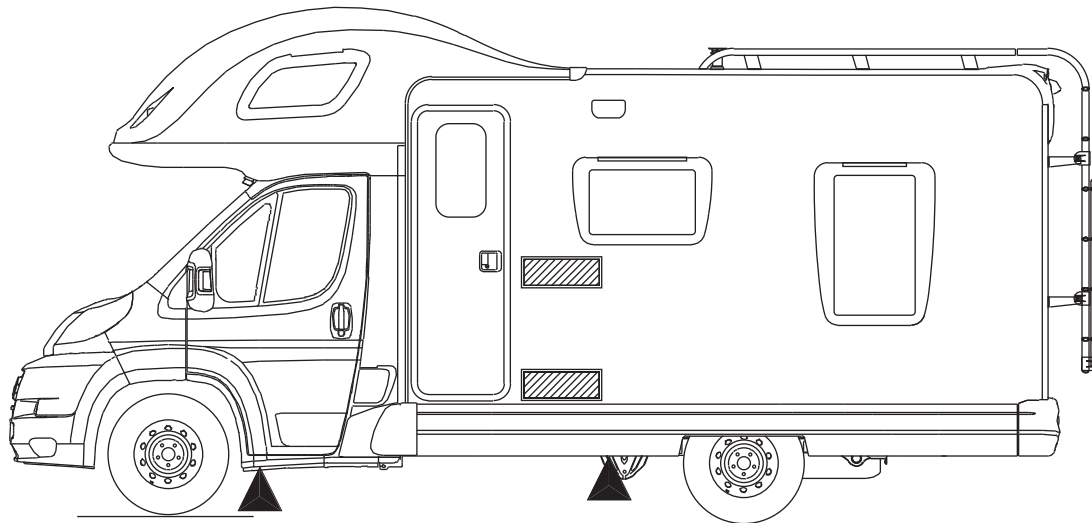

Jacking Points for High-Line and Low-Line: ▲

SWIFT SUNDANCE GENERAL BODY SYSTEMS

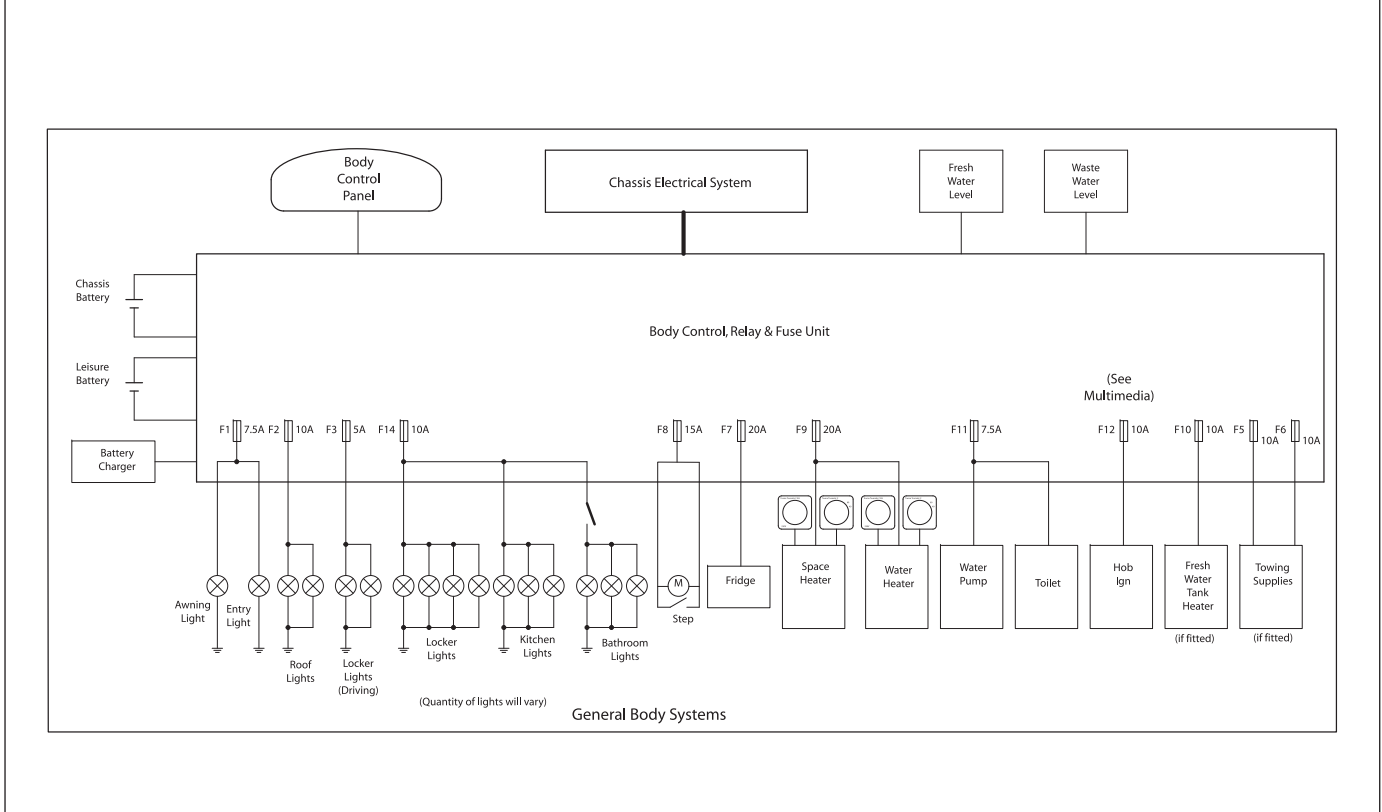

Wiring Diagrams

SWIFT SUNDANCE STATUTORY LIGHTING

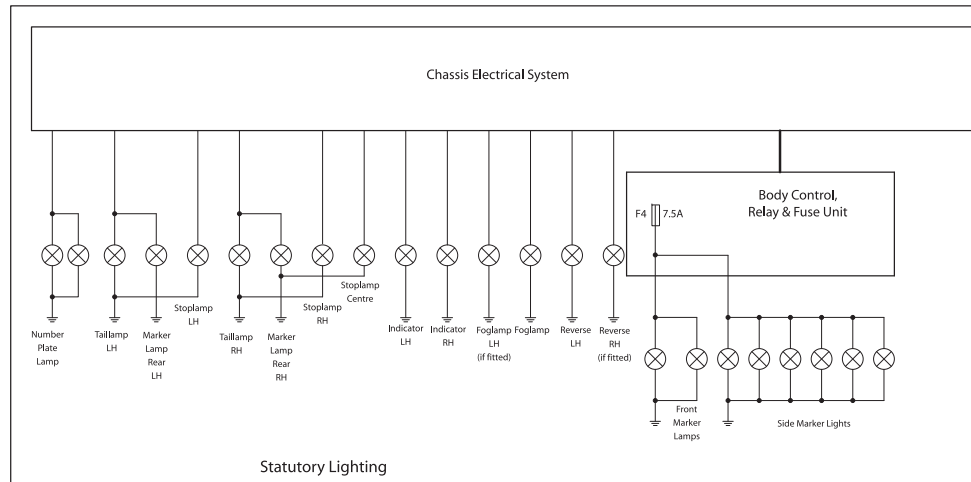

SWIFT SUNDANCE 230V AC SYSTEMS

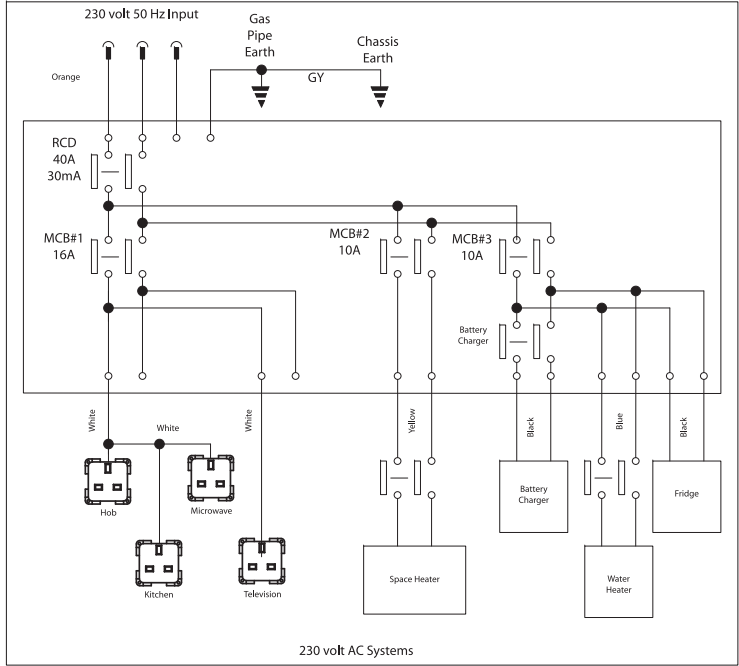

Wiring Diagrams

SWIFT SUNDANCE MULTIMEDIA SYSTEMS

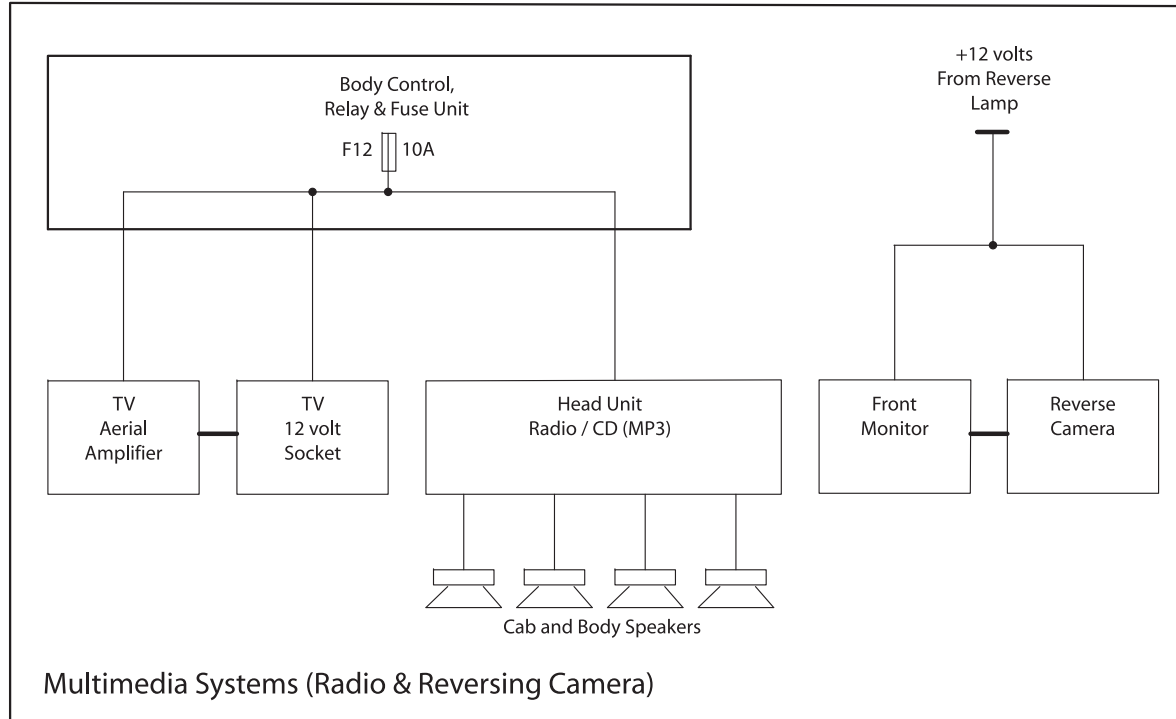

Bulb Replacement

SWIFT SUNDANCE				
	Bulb Reference	Bulb Rating		
EXTERIOR LIGHTS				
Front marker light	W5W	12V 5W		
Side marker light	W5W	12V 5W		
Rear high level marker light	W5W	12V 5W		
High level stop lamp	T5 / 13.5	12V 2.3W		
Rear indicator lamp	PY21	12V 21W		
Rear stop / Tail lamp	P21/5W	12V 21W / 5W		
Rear reverse lamp	P21	12V 21W		
Rear fog lamp	P21	12V 21W		
Number plate light	C5W	12V 5W		
INTERIOR LIGHTS				
Downlighters	Halogen capsule	G4 12V 10W		
Locker spotlights	GU4 / MR11 Dichroic	GU4 12V 10W		
Kitchen locker light	300mm Fluorescent	12V 8W		
Panel mounted fluorescent lamps	300mm Fluorescent	12V 13W		
Skylight surround fluorescent lamps	300mm Fluorescent	12V 8W		
Luton fluorescent lamps	300mm Fluorescent	12V 8W		
Drop down monitor surround lamps	GU4 / MR11 Dichroic	GU4 12V 10W		
Drop down monitor integral lamps	Halogen capsule	G4 12V 5W		
Awning lamp	P21W	12V 21W		
150mm diameter white ceiling light	Halogen Capsule	G4 12V 5W		

Note: Not all lights and bulbs feature on all models within a range

NOTES

