

# GENERAL CARE AND MAINTENANCE

<b>Chassis</b> .....	32
<b>Checking the External Structure</b> .....	32
<b>Windows and Doors</b> .....	34
<b>Kitchen and Bathroom</b> .....	35
<b>Furnishings</b> .....	37
<b>Furniture</b> .....	38
<b>Security</b> .....	38
<b>Alignment and adjustment of doors</b> .....	39
<b>Entrance door and hinge adjustment</b> .....	40
<b>Hinge adjustment</b> .....	40
<b>Lock keep adjustment</b> .....	44
<b>Vinyl Flooring</b> .....	45
<b>Internal</b> .....	45
<b>Electrics</b> .....	45
<b>LPG</b> .....	46
<b>Winterisation</b> .....	47

## General Care

### CHASSIS

#### GALVANISED CHASSIS

The chassis is Hot Dipped Galvanised. Hot dip galvanising has been used for many years throughout the automotive industry and is widely regarded as one of the best forms of corrosion protection.

When the steel is withdrawn from the galvanising bath it has a clean, bright surface. Over a period of time this changes to a dull grey colour as the surface zinc reacts with oxygen, water and carbon dioxide in the atmosphere to form a tough, stable, protective layer.

During this time, if galvanised items are stored in damp or wet conditions, where there is little or no air movement, then the zinc will continue to react with the moisture that is present. In so doing the zinc will produce excessive amounts of zinc hydroxide. This is seen as a bulky white deposit on the surface of the galvanising and is often referred to as wet storage stain (white rust).

In the case of Leisure Accommodation Vehicles, you can help to prevent wet storage stain (white rust) occurring. You can do this by washing the chassis with clean water as soon as they are delivered. You must then allow an adequate flow of dry air to ensure that they dry off completely.

Should wet storage stain (white rust) occur on a product however, then it can sometimes be removed using a stiff bristle brush or a “Scotchbrite” pad.

Because of its post process nature “Wet Storage Stain (white rust)” is not covered under Warranty procedures. If, however, it can be shown that the galvanising process was defective in some way i.e. areas not galvanised, then an inspection can be arranged and action agreed upon.

#### PAINTED CHASSIS

It is imperative that as a minimum, annual inspections take place to all painted steel areas to assess any degradation of the paint system.

The finish on a caravan chassis is under constant attack from sunlight, coastal air, pollution, dust and frost. To this end it is recommended that the chassis is regularly inspected and washed as appropriate.

Maintenance may be required at more frequent intervals because of fading, chalking, chemical contamination, wear and tear, or for aesthetic or other reasons.

Mechanical damage to the paint system will result in a significant reduction in the paint durability. Hence, mechanical damage must be identified at an early stage and

appropriate touch-up procedures followed to the effected areas.

Minor paint damage, such as chipping, can be touched up with approved paint, available through your dealership.

### CHECKING THE EXTERNAL STRUCTURE

Inspect visually for damage to panels, gutter and other external features. Signs of damage, leakage and movement should be repaired as necessary.

#### SAFETY WARNING

ENSURE THAT ALL NECESSARY WORKING AT HEIGHT SAFETY PRECAUTIONS ARE IN PLACE BEFORE CLIMBING ONTO THE ROOF.

#### WARNING

TO AVOID DAMAGING THE ROOF USE A 15MM OR THICKER SHEET OF PLYWOOD OR SIMILAR. IT MUST BE WIDE ENOUGH TO SPAN OVER TWO ROOF SPARS WHICH ARE APPROXIMATELY 400MM CENTRES, A SHEET 1220MM X 1220MM (4'X 4') SHOULD BE SUITABLE WHEN POSITIONED CAREFULLY ON THE ROOF.

Visually inspect for damage of the roof structure, check all visible mastic seals for signs of shrinkage or cracking and re-seal where necessary.

The water system should be inspected for leaks and rectified as necessary.

### BLOCKAGES

If you have a waste water or toilet blockage, the first thing to check is that the site main drainage is clear as any blockages here could back-up to your holiday home. If it is clear and you have a toilet blockage we would recommend that you call a plumber, unless you are aware of what could have caused the problem and are competent to address the problem. If it is a waste blockage, you should first check and clean out traps situated under the sink, basin and shower tray (if fitted). If you still have a blockage, then it must be in the feeder pipes to the main sewerage pipes or the main sewerage pipe. You should consult a **PLUMBER OR YOUR PARK OFFICER AT THIS STAGE** unless you are competent to do the job.

### GUTTERS AND DOWNPIPES

It is important that all gutters and down pipes are kept free from obstructions and blockages. Inspect regularly.

### EXTERIOR PANELS

#### ALUMINIUM PANELS

The aluminium exterior of your holiday home is pre-painted, oven dried aluminium sheet and is very easy to keep clean. The cleaning method recommended is to wash down with plenty of clean water and very mild detergent.

An occasional polish with a good quality wax will help obtain a high gloss finish. Under no circumstances should an abrasive or harsh cleaner be used. Stubborn marks, such as bird soiling, grease etc. can be removed by rubbing with a soft cloth dampened with White Spirit.

Aluminium panels will expand in direct sunlight as the panels heat up. This is normal and they will contract back as the temperature lowers.

#### CANEXEL PANELS

CanExel prefinished siding is produced from wood fibre, resin, and wax fused under pressure. This engineered wood paneling is highly stable, as well as highly resistant to moisture. The finish on CanExel siding consists of five coats of baked-on paint and a sealer top coat.

Cleaning is as for aluminium panels. Small scratches and other minor damage can be repaired with the use of CanExcel retouching paint. Details can be found at [www.canexel.co.uk](http://www.canexel.co.uk).

#### PVC PANELS

These panels are low maintenance, which will never need painting or preserving and with the required care and attention will stay looking good for years.

To maintain the appearance, it will be necessary to wash the panels with warm soap and water to remove surface dirt. The frequency of cleaning will depend upon the local environmental conditions. Copious amounts of soapy water should be used to avoid any chance of scratching the surface.

When wiping always use a soft cloth or sponge:

NEVER use solvent based cleaners

NEVER use abrasive cleaners.

**WARNING:** Do not wash your Holiday Home with a high pressure washer as these can permanently damage the exterior panels and seals of your Holiday Home

#### SNOW PRECAUTIONS

Great caution should be taken when cleaning snow from the roof of the holiday home.

## General Care

### DOORS AND WINDOWS OPERATION OF DOOR LOCKS

#### OPERATION OF DOOR LOCKS

To unlock the door from the outside, insert key and turn anticlockwise, pull on the handle. To lock, push the door to the closed position so that the first stage lock engages. Lift the handle upwards to engage the extra security roller locks, insert the key and turn clockwise to engage the deadlock.

#### OPERATION OF NIGHT VENTS (IF FITTED)

The window frame will have been fitted with a secondary keep within the rebate. You can close the handle to locate the spur inside this keep, which will lock the window but allow a level of ventilation.



Fully closed



Night vent position

### DOOR AND WINDOW HANDLES

Apply silicone spray and wipe off excess with a soft cloth.

Lock cylinder. Lubricate with PTFE (union part no. 9075) or similar. Apply the key flutes, insert the key and operate several times to ensure even distribution. Latch, dead bolt and roller locks. Apply petroleum jelly/Vaseline. This acts both as lubricant and water repellent.

Doors and window hinges: - No lubrication is required, smear with Vaseline to protect against water.

Window friction stays: - Protect with a mild detergent oil or a very light lubricant, use sparingly as oil does attract dirt.

#### RECOMMENDED MAINTENANCE

Lubricate every 6 months.

#### MINIMUM RECOMMENDED CLEANING INTERVALS

**Monthly.** Frames, door and window furniture. Wash with warm water and a mild detergent. It is important to ensure that all dirt and debris is regularly removed from the internal rebate of door and windows. Cleaning cloths should be in-bleached cellulose/cotton material. Do not use cloths containing synthetic fibres.

**Six monthly:** Clean with a proprietary brand of UPVC cleaner.

**IMPORTANT:** Make sure that you follow ALL the recommendations and cautions supplied with the product.

#### REPAIRS

On white profiles only, stains and scratches can be removed by sanding and polishing. Use a 320/400 grit sanding disc and polish using sisal rotary brush to bring back the surface finish.

It is important that you achieve a smooth even finish before beginning the polishing stage.

On wood grain surfaces, care should be taken when cleaning. Any white areas showing as a result of damage or cleaning can be retouched using a wood grain marker pen. If you have a breakage or a crack please contact your nearest glazier. Handle any broken glass with care and dispose of with safety of others in mind.

#### Do's and don'ts for UPVC products

##### Do

- Clean the glass regularly with a good quality liquid spray glass cleaner.
- Frequently wash down the UPVC with plenty of warm soapy water (use liquid general purpose cleaner) and wipe dry.
- Only use cleaning materials which do not impair anti-corrosion properties

- Use cream cleaner for isolated stubborn stains on white UPVC only. Apply with a damp cloth using minimal pressure.
- Ensure drainage slots are kept unblocked and free from dirt, spider's webs, etc.
- Keep all tracks clear of dust and debris in order to reduce the wear on sliding parts.
- Ensure that all gutters and their outlets are kept clear of leaves and debris to maintain efficient operation.
- Replace damaged or worn parts with original parts by an authorised specialist.

### Don't

- Use cleaners on any UPVC.
- Use abrasive paste or cream
- Use excessive pressure when cleaning UPVC.
- Use high pressure or steam cleaners.
- Use any type of bleach, solvent (e.g., white spirit, methylated spirits, nail varnish remover) or adhesives.
- Use any unspecified tools.
- Use any abrasive papers, such as sandpaper.
- Use abrasives or brass cleaner on furniture: handles, door knockers, letter plates.
- Use excessive loads on the windows and doors.

- Fail to maintain the product as indicated.
- Paint or try to remove paint.
- Lean ladders against guttering.

## KITCHEN AND BATHROOM

### TOILET/SHOWER ROOM

#### THERMOSTATIC MIXER VALVE(SHOWER)



All Thermostatic Mixing Valves (TMV's) must be carefully protected against frost damage. TMV's should be removed or correctly drained down during months in which frost may occur.

The Thermostatic Mixer Valve controls accurately the temperature of water for

showering. The valves also maintain the pre-set temperatures even if the water pressure varies when other appliances are used. This significantly reduce the risk of scalding when showering.

### Function

Hot and cold water entering the valve is mixed to a temperature pre-selected by the user or installer. This is achieved automatically by a thermally sensitive mechanism within the valve that proportions the amount of hot and cold water entering to produce the required blend. The mechanism then automatically compensates for any variations in supply pressures or temperatures to maintain the pre-selected temperature. In the event of cold water supply failure, the thermostatic mixing mechanism will automatically shut down the flow to prevent discharge of dangerously hot water

### Operating pressure:

Dynamic pressure: - 0,5 bar min./ advisable 1 bar  $\leq P \leq 5$  bar.

Static pressure 10 bar max.

Valves operating outside the above conditions of use cannot be guaranteed to operate as Type 2 valves.

The valve is designed for use as a high-pressure valve; it is tested against BS EN 1111.

## General Care

If a water supply is fed by gravity then the supply pressure should be verified to ensure the conditions of use are appropriate for the valve.

**ATTENTION:** in order to assure the maximum efficiency of the mixer, the operating pressures (on hot and cold line) should be kept as balanced as possible and the inlet hot water must be at least 10°C above the required blend temperature.

When pressure is higher than 5 bar a pressure reducer is required to be fitted before the mixer.

### DRAIN DOWN PROCEDURE

1. Close hot and cold mains feed taps.
2. To drain Thermostatic mixer:
  - Remove the shower hose from the mixer or lay the showerhead and hose in the shower tray to drain off any trapped water.
  - Turn bottom tap valve fully open
  - Turn the top thermostat valve fully clockwise to drain cold water, until water stops flowing.

Push in the red temperature set button on the top thermostat valve and turn fully anticlockwise to drain the hot water side until the water stops flowing.

**Note:** If after the drain down procedure the Thermostatic Mixer Tap is to be left for long

periods in cold or freezing conditions, leave the tap open and line up the ridge on the thermostat hand wheel with the letter “H” etched on the tap body.

### PROTECTING YOUR THERMOSTATIC MIXING TAP

In addition to draining down the Thermostatic Mixer Tap in periods of cold and freezing conditions, to offer maximum protection it is highly recommended that the Thermostatic Mixer Tap is further protected by following the method outlined below:

First complete the drain down procedure ensuring the hot and cold feeds are isolated and fully drained.

Using an allen key, remove the mixer body from the tails by releasing the grub screws taking care not to misplace these.

The unit can then be completely drained, dried and wrapped in a soft cloth for storage away from frost until required.

The Thermostatic Mixer Tap can then be re-attached as follows;

Re-fit body to the tails and tighten the grub screws, take care not to over tighten.

Re-connect to the water supplies and check seals.

### PROTECTING YOUR THERMOSTATIC MIXER VALVE (BATH)

In addition to a shower Thermostatic Mixer Tap, if the Holiday Home has a bath fitted there will be a Thermostatic Mixer Valve to regulate the water temperature to the bath, this will be accessed by removing (lifting) the lid covering the toilet system. This should be removed or correctly drained down during months in which frost may occur.



**FOR INFORMATION THAT IS MORE COMPREHENSIVE REFER TO YOUR V100 TMV2 USER AND MAINTENANCE INSTRUCTION BOOKLET.**

### CLEANING

Your fitting has a high quality finish and should be treated with care to preserve the visible surfaces.

All surface finishes will wear if not cleaned correctly. The only safe way to clean your mixer is using soap water and a cloth. To dry use a soft cloth. Stains can be removed using

washing up liquid. All bath cleaning powders and liquids will damage the surface of your fitting even the non-scratch cleaners.

### BATHROOM FITTINGS

High quality plastics are used in the construction of the shower room fittings. Never pour very hot or boiling water directly onto the basin or onto the shower tray - always add cold water first.

Plastics can be cleaned using a very mild detergent in tepid water. Never use abrasive cleaner or chemical cleaner. NB. It is important not to pour hot water directly into or onto any plastic.

Always start with cold water and add the hot to achieve the desired temperature.

The shower cubicle and sanitary ware should be cleaned with detergent and warm water. Never use abrasive cleaners.

### TAPS

These fittings have a high quality finish and should be treated with care to preserve the visible surface.

All surface finishes will wear if not cleaned correctly. The only safe way to clean is using soap and water and a cloth. To dry use a dry soft cloth. Stains can be removed using washing up liquid.

Most bath cleaning powders and liquids will damage the surface of your fittings even the non-scratch cleaners

### KITCHEN

The kitchen worktop, sink, drainer and cooking equipment surfaces should only be cleaned with hot soapy water, unless the appliance manufacturer says otherwise in their own literature. Do not use abrasives and particularly not wire wool. The inside of ovens should be cleaned in accordance with the instructions contained in the manufacturer's leaflet.

### BRANDED APPLIANCES AND COMPONENTS

YOU SHOULD NOT USE THE APPLIANCE BEFORE READING THE MANUFACTURER'S INSTRUCTIONS.

PLEASE READ AND UNDERSTAND ALL OPERATING INSTRUCTIONS PROVIDED BY EACH MANUFACTURER BEFORE USING THEIR APPLIANCE.

Most of the appliances fitted into your holiday home have an instruction leaflet issued by the manufacturer and you will find this leaflet either with the appliance or placed inside a kitchen unit in your holiday home. If one cannot be found, please notify your park/supplier who will write to the appliance manufacturer on your

behalf or give you their name and address if you wish to make contact with them.

### FURNISHINGS

#### UPHOLSTERY CARE

##### Cleaning

Dust, dirt and grit should be removed frequently, as this will affect the durability and colour of your fabric. Remember, people dust wooden furniture because they can see dust particles, so please bear in mind that an amount of dust continually settles on your upholstery and may be allowed to remain because it is not visible. Please vacuum or brush your furniture frequently.

##### Spills and stains

Always deal with stains immediately. In the first instance remove excess with a soft absorbent cloth or white paper tissue. Cleaning instructions will vary according to the type of fabric you have selected.

##### Creasing

All fabrics are likely to crease, particularly on the arms and cushions. This is not a fault, but a natural feature, and will not affect the fabric's wearing qualities.

## General Care

We strongly advise against washing any fabric, if in doubt, consult professional cleaning specialists.

### Heat and light

Never leave your furniture in direct contact with or too close to a heat source, e.g. a radiator or space heater. Avoid standing the furniture permanently in direct sunlight as the fabric colour may fade.

### CARPET

Any proprietary carpet cleaner may be used, but it is recommended that you do not use excessive amounts of water.

### VINYL FLOOR COVERING

Proper care of your floor prevents damage, extends its life and keeps it looking new for years.

Always vacuum or dust hard floor surfaces before mopping. Vinyl floors generally require only warm water for cleaning

### FURNITURE

Use a damp cloth to remove finger marks, etc. or an all-purpose spray cleaner or a good quality furniture oil or abrasive cleaners.

It is recommended that cupboard catches, stays, sliding bolts and hinges are kept clean and lightly oiled or smeared with petroleum jelly.

## SECURITY

### PROTECTING YOUR HOLIDAY HOME AND POSSESSIONS

#### Windows and doors

Always close and lock windows and doors when leaving your holiday home, even if only for a few minutes. Consider fitting additional locks wherever necessary; ask your park/distributor/dealer for details on security locks.

It is very important, however, that any additional locks fitted to designated escape routes (i.e. door(s) and windows) are immobilised during occupation so that your escape remains unhindered.

#### Gas Cylinders

Keep them chained together and fastened to the substructure of your holiday home. Always use a good quality padlock.

#### Lights and alarms

Many devices, both battery powered and electrical, are available to the DIY enthusiast. A light inside your holiday home at night suggests it is occupied. Electricity triggered to turn on

as darkness falls or battery operated with a time switch, the light will help deter thieves. Ask your park/distributor/dealer for details on electrical intruder alarms.

Marking your property with your postcode and house number would help the police identify the owners of stolen goods. Advertising the fact that your property is so identified may act as a deterrent. Property can be marked by etching, die-stamping, branding, engraving or by using a security marker pen.

Organise yourselves on the holiday home park so that everyone keeps an eye open for strangers or anything suspicious.

Report any unusual activity to the park manager or the police.

Holiday homes on parks are vulnerable not only in summer but also in winter.

When your holiday home is left unattended for long periods, take any extra precautions and remove any items that are valuable or portable.

For free crime prevention advice about securing your holiday home, protecting your valuables or property marking either at home or whilst on park, contact the Crime Prevention Officer through your local police station.

### ALIGNMENT AND ADJUSTMENT OF DOORS

If the entrance door becomes misaligned the hinges can be adjusted to bring the door back into alignment. The lock keep can also be adjusted to ensure that the lock engages correctly.

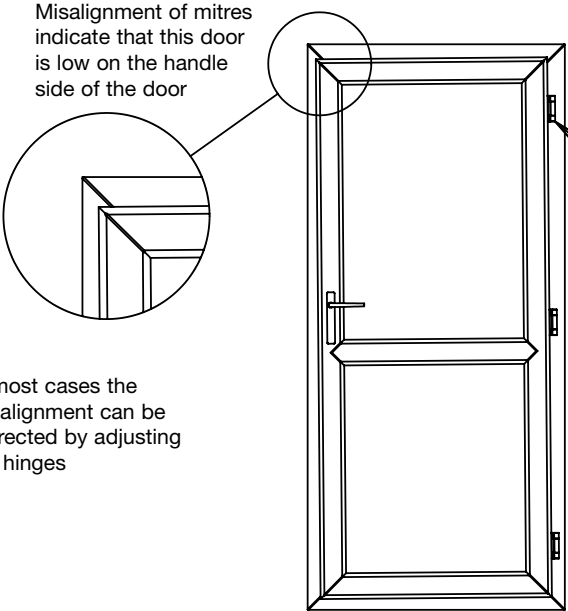
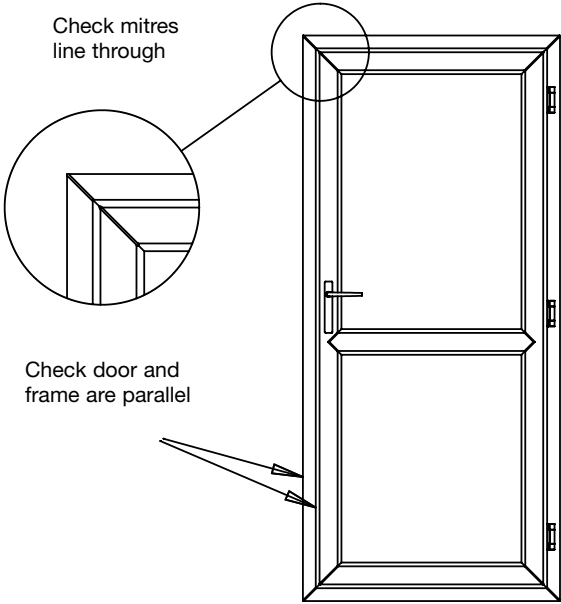

In most cases the misalignment can be corrected by adjusting the hinges

## General Care

### ENTRANCE DOOR HINGE AND LOCK ADJUSTMENT

If the entrance door becomes misaligned the hinges can be adjusted to bring the door back into alignment the lock keep can also be adjusted to ensure the lock engages correctly.

### HINGE ADJUSTMENT

- Open the hinge covers
- Loosen the fixing screws
- Adjust the door laterally using a 5mm Alan Key
- Adjust the height of the door using a 4mm Alan key
- When the door is in the desired position tighten the fixing screws and close the covers ensuring that they are snapped shut.



Hinge in the supplied position



To adjust the door vent horizontally (left to right).  
Open the door and push in the plastic clip.



This will release the hinge cover.

#### Adjustment available

Height (from lowest Position) +7mm  
Compression (from mid position) +/- 1.75mm  
Lateral +/- 5mm



**Pull back the cover**

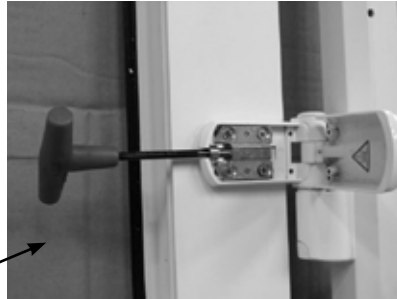

**Insert 5mm A/F Alan key and turn to move the vent left or right. This will increase or decrease the clearance between the door vents and the keep. If the screw is difficult to turn it may be necessary to loosen the fixing screws. They should be tightened after the required adjustment has been made.**



**Adjusting the hinge as shown will correct this clearance.**

## General Care



To adjust the door vent compression and height within the frame unclip the cap as shown.



This bolt is used to adjust height and compression.

Insert 4mm A/F Alan key to adjust the vent height within the frame and the vent to frame compression.

As the Alan key is turned clockwise clicks are felt and the vent will rise. When the correct height has been reached the compression should be adjusted left or right clicks. The compression gap should be set at 3mm. To lower the vent turn anti clockwise and repeat the steps.

**IMPORTANT:** Adjusting the hinges will not compensate for a door aperture and frame that are out of square. If The Diagonal measurements shown vary by more than 5mm or the width measurements vary the Holiday Home should be levelled or the frame installation corrected. The hinges can then be used to fine tune the door operation. Any adjustment should normally be made to all hinges; otherwise the door vent could become twisted.

Diagonal Measurement

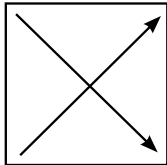

Width Measurements should be equal

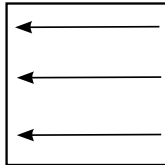

# General Care

## LOCK KEEP ADJUSTMENT

The Lockmaster 3 Deadlock System as illustrated to the left is a new locking mechanism developed specifically for the leisure home market. Each of the deadlocks and the latch have +20mm and -20mm vertical movement to aid locking during manufacture, transport and siting. In addition, both the top and bottom keeps and the centre latch have +2mm and -2mm of lateral adjustment to aid site fitting

To adjust the latch and keep plates use a No 2 Phillips screwdriver to release the adjustment screws and move the plate to as required. Please note that the plate and body of the keep assembly have serrations to help them lock together upon tightening of the screws

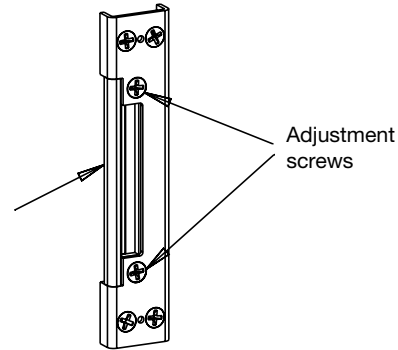
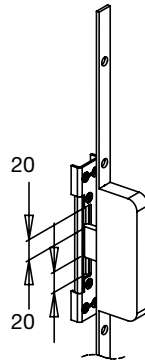

### Extent of travel

Normal setting

+2mm setting

-2mm setting

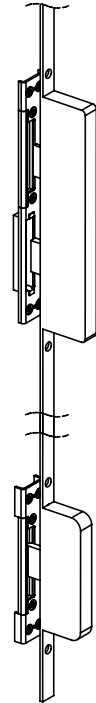
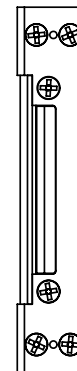
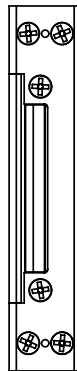

## VINYL FLOORING

Vinyl flooring risk being stained by in-ground dirt if they are not cleaned regularly.

- Avoid using waxes or polishing products
- Do not use rubber protectors on the feet of chairs and furniture. Use plastic protectors instead.
- Put rigid floor protectors beneath the feet of heavy pieces of furniture to prevent the formation of permanent indentations.
- Some materials or colourants such as tar, grease, oil, dyes, waxes, ballpoint or marker inks etc. may under certain conditions migrate into the wear layer and cause indelible stains.
- Natural or intense artificial light causes a whitening effect on all floor coverings. This phenomenon becomes visible in comparison to those areas covered by rugs or furniture, which appear yellower. This yellow effect disappears after a few weeks when these areas are once again exposed to light and the whitening effect appears.

The use of a doormat without a rubber backing is recommended for doorways leading to the exterior, in order to protect the surface of the floor covering from grit and abrasive particles brought in on the soles of people's shoes.

## REGULAR MAINTENANCE

**Daily cleaning:** using soft dry broom or vacuum cleaner.

**Weekly cleaning:** using neutral detergent in water with fringed mop or floor cloth.

## INTERNAL

### INTERNAL WALLS

All internal walls with an external side should be visually checked for damp and repaired as necessary.

### SURFACE PROTECTION

Never use a knife or sharp instrument directly on worktops or unit surfaces.

### BUNKS

NOTE: - IF UPPER BUNKS ARE FITTED, CARE SHALL BE TAKEN AGAINST THE RISK OF FALLING OUT. UPPER BUNKS ARE NOT SUITABLE FOR CHILDREN UNDER 6 YEARS OF AGE WITHOUT SUPERVISION. ALWAYS ENSURE THAT THE FALL OUT PROTECTION IS IN PLACE WHEN THE BUNK IS IN USE. SEE BUNKS IN THE SAFETY SECTION.

## ELECTRICS

The electrical supply to your holiday home on some holiday parks is restricted. Please check with you park manager before using additional appliances within your holiday home. In case of doubt consult the park owner or his agent.

The Residual Current Circuit Breaker (RCCB) or Residual Current Device (RCD) serves as the main switch for your holiday home. It is also the main emergency shut off switch for your holiday home. It is a safety device designed to protect you from the possibility of shocks that could arise from a faulty power pack supply, faulty appliance or a fault on the holiday home causing the current to run to earth.

The RCD has been factory tested for correct operation. The RCD should be tested each time you switch on the mains supply and/ or every month.

- With the supply connected, switch RCD to ON.
- Press test button marked 'T'.

Periodic testing and inspection of the electrical system should be carried out as described on page 35.

## General Care

### LPG

The LPG installation and LPG appliances in your holiday home should be checked annually by a Gas Safe registered operative. Contact your holiday home park or Gas Safe on 0800 408 550 for a list of recommended

#### CHANGING GAS CYLINDERS

The following procedure should be adopted.

1. Extinguish any fire, flame or source of ignition (including cigarettes, pipes and pilot lights) before changing gas cylinders.
2. Ensure that the gas cylinder valve(s) is/are closed before disconnecting any empty cylinder or before removing the plastic cap or plug on the outlet connection of the replacement cylinder (note: Left hand thread).
3. Ensure that the replacement gas cylinder is the correct one for the installation.

Make firm gas tight joints. Any leaking vapour will smell. If a leak is suspected after changing gas cylinders and opening valve, test by brushing with soapy water around the joints. Bubbles will form if vapour is leaking.

Flexible hoses should be regularly inspected and replaced when signs of cracking or other deterioration appears. After

replacement, ensure that the ends are well secured and gas tight..

#### NEVER USE A NAKED FLAME WHEN CHECKING FOR LEAKS.

Gas cylinder valves are of various designs depending on the type of cylinder and the use for which it is intended and it is essential that the correct pressure regulator with the correct pressure setting and capacity for the installation is used in accordance with the manufacturers instructions.

In the case of a connection on a pressure regulator or gas appliance which relies upon a sealing washer(s) to maintain a gas tight joint, it is essential to check that the washer is present, sound and correctly positioned prior to making the connection. Where the connection relies on a metal seating or bull nose connection to obtain a gas tight joint it is essential that the mating surfaces are clean and undamaged. In no case should a damaged valve or connection be used.

Where connections are designed to be tightened with a spanner it is essential that a spanner of the correct size is used and that the union is firmly tightened (hand tightness is not sufficient). When self-sealing valves are incorporated in a gas cylinder, connections should be made in accordance with the manufacturer's instructions and tools should not be used.

### GAS LEAKS

- (a) If a gas leak is suspected, close the gas cylinder valve or other valve at the inlet to the holiday home. Do not operate electrical switches. Open all doors and windows to disperse any gas escape.
- (b) The strong unpleasant smell of LPG will enable the general area of the leak to be detected. Check that gas is not escaping from an unlit appliance. In the case of a leak, close cylinder valve(s) and call a competent installer to rectify the fault.

If a leaking gas cylinder cannot be stopped, remove the cylinder to a safe place in the open air in an upright position away from drains and any source of ignition.

### NEVER BLOCK VENTILATION GRILLS OR GAS DROP HOLES.

ALL APPLIANCES ARE FITTED IN ACCORDANCE WITH SPECIFICATION LAID DOWN BY EACH MANUFACTURER AND THEY HAVE UNDERTAKEN THEIR OWN INSPECTION OF INSTALLATION AND GIVEN THEIR APPROVALS.

MOST OF THE BRANDED APPLIANCES CARRY THEIR OWN WARRANTY AND AFTER SALES SUPPORT. IN THE EVENT OF EITHER BEING REQUIRED, PLEASE FOLLOW THE DIRECTIONS OF THE WARRANTY OR CONSULT YOUR OWN SUPPLYING DEALER.

SURFACES OF APPLIANCES BECOME HOT IN USE. ANY GUARDS PROVIDED MAY NOT GIVE FULL PROTECTION TO THE YOUNG OR ELDERLY.

### WINTERISATION

The following items are the procedures for preparing your holiday home for winter storage. Virtually all apply whenever the unit is to be unoccupied for any long period when frosts can be expected.

- (a) Turn off LP gas supply at the cylinder and remove regulator and hose for storage inside. Ensure that the open gas inlet is protected against entry of dirt or insects.
- (b) Turn off mains water stop tap.
- (c) Open, drain off fresh water, outlets on the underside of the holiday home. Do not drain the central heating if fitted.
- (d) Open all hot and cold taps.
- (e) Drain off the water heater and domestic water part of the water boiler as per the user instructions for the water heater / boiler supplied with the holiday home.
- (f) Thermostatic Mixer Valves require full protection from frost, they should be removed or drained correctly. Refer to the Thermostatic Mixer Valve instructions in the Kitchen and Bathroom section of this Handbook
- (g) Flush all toilets.
- (h) When all water is drained, close the drain off outlets and all the hot and cold taps.
- (i) Fridge / Freezer
  1. Turn the fridge off and allow to defrost. Clean the inside of the fridge / freezer
  2. Prop the fridge / freezer door open, and the internal freezer door if applicable for ventilation.
  3. If a fridge freezer with icemaker and water filter facilities is fitted, draining down and removal of the filter is recommended to prevent frost damage to the filter during cold and freezing conditions.

The filter water pipes are connected to the filter with push fit water pipe fittings.

With a flat bladed screwdriver or similar blunt instrument, carefully depress the water pipe fitting collar as shown in Fig.1. Take care not to score the filter pipe as this may prevent a water tight seal when the filter is reconnected. Holding the collar tight to the fitting, carefully remove the filter.



Fig.1



Fig.2

(j) If a dish washer or washing machine is fitted it should be protected from frost damage by carrying out the following instructions:-

1. Remove electrical power to the dishwasher.
2. Turn off the water supply and disconnect the water inlet pipes from the water valves.
3. Drain water from the inlet pipes and water valves. (Use a pan to catch the water).
4. Reconnect the water inlet pipes to the water valves.

## General Care

- 5 Dish washers only - Remove the filter in the tub at the bottom and use a sponge to soak up water in the sump.
- 6 Washing machines only - Drain the water from the pump by removing the filter. See washing machine instructions for how to do this.
- (k) Pour anti-freeze or common salt into the WC pan and also the sink, basin and shower waste traps. Avoid these substances coming into contact with metallic surfaces such as stainless steel sinks or waste outlet and remove any spillage. We recommend the use of a small funnel.
- (l) Switch off and unplug all electrical appliances (including TV Aerial plug). Turn mains control switch to off position.
- (m) Remove all food. Thoroughly vacuum all carpets and vinyl to remove any traces of food.
- (n) Empty the vacuum and or fit a clean bag.
- (o) The kitchen sink should be free of all particles and left clean.
- (p) Carry out a full lubrication schedule (i.e. locks, hinges, jockey wheel).
- (q) Clear gutters and fall pipes to prevent debris blocking the system.
- (r) Wash and polish exterior paintwork.
- (s) Close and secure roof light (where fitted) and all windows making sure no curtains are trapped but are hanging free.
- (t) Preferably, soft furnishings should be removed and stored in ideal conditions, or, if they are to remain within the unit, it is advisable to place cushions and mattresses separately on end or edge to allow a free movement of air around them.
- (u) Secure exterior windows. Many people leave bowls of water-absorbing crystals or common salt as a means of withdrawing moisture from the air. No moisture means no mildew and damp, so the practice is worthwhile.
- (v) Ensure all fixed ventilation points (high and low) are clear from debris and obstructions.

**CENTRAL HEATING: Do not drain off the radiator system, it is a sealed system protected by an anti-freeze solution.**