

Vehicle modification and non-standard parts .....	160
Caravan movers .....	160
Caravan exterior .....	160
Caravan interior .....	162
Winterisation/storage .....	164
AL-KO chassis .....	168
AL-KO ATC control system.....	168
Axle types .....	173
Operating instructions for AKS 3004 .....	178
AKS 3004 Delivery Specifications .....	179
Manoeuvring.....	181
Chassis Maintenance & Cleaning .....	182
Chassis trouble shooting .....	186
Chassis accessories .....	189

## MODIFICATIONS

**VEHICLE MODIFICATIONS & NON-STANDARD PARTS**

As the owner of a Swift Group Product, you are able to make any modifications you wish, either by yourself or through a dealer, without affecting the Swift 3/6 Year Warranty.

However, please be aware that any issues, resulting directly or indirectly, from a modification or fitment of a non-standard part, will not be covered by The Swift Group Warranty.

**WD40 is not recommended for external or internal use**

**WD40 attacks paintwork and sealants.**

**If a lubricant is required for Interior hinges, Sliding door tracks, Bottle box hinges, Exterior door hinges, Plastic tracking etc. We recommend "Ambersil 40+" this is readily available from most DIY/ Automotive spare part retailers**

Before carrying out any DIY work within the warranty period (3/5) years please check with your Swift Group dealer.

**CARAVAN MOVERS**

If thinking of installing shock absorbers or a caravan mover as an after fit it is advisable to consult your dealer, as this may not be possible with shock absorbers (if fitted).

**CARAVAN EXTERIOR****Aluminium Panels**

The stove enamelled paintwork is very durable and easy to clean owing to the high gloss properties.

**Plastic Panels (GRP/ABS)**

These are used for front and rear panels and, in some cases for the roof.

**Cleaning**

For both aluminium panels and plastic panels.

1. Wash the caravan regularly with mild detergent. Rinse with cold water and leather off.
2. For better protection a similar coloured good quality car wax may be applied.

For sealed areas a mild soap is the best way to clean without affecting the sealant.

Acid or alkaline based cleaners or solvents should not be used.

**WARNING:** Under no circumstances use any abrasive cleaning agents or solvents on the exterior panels.

Care should be taken as the silicon in some polishes can attack the rubber used on the exterior for seals and gaskets.

**Acrylic Windows**

Wash windows carefully, as you would with the paintwork of your car, do not scrub windows prior to removing surface dirt and film with a hose pipe - trapped dirt could cause scratching.

Wash with a solution of warm soapy water, windows can then be dried off with a leather.

Small scratches can be removed, consult your dealer.

Catches and stays do not require any special attention or lubrication.

## Condensation

### What is condensation?

Condensation is the change of water from its gaseous form (water vapour) into liquid water. Condensation generally occurs in the atmosphere when warm air rises, cools and loses its capacity to hold water vapour.

As a result, excess water vapour condenses to form droplets.

### Why condensation occurs

Condensation occurs when warm moist air meets a cold surface. The risk of condensation therefore depends upon how moist the air is and how cold the surfaces of the vehicle are. Both of these depend to some extent on how the vehicle is used. In a Caravan with a cold outside wall, if the temperature of the wall falls below the dew point temperature, it is quite normal for condensation to occur predominantly on the external walls.

### When condensation occurs

Condensation occurs usually in winter, because the Caravan is cold and because skylights, windows and doors are opened less and therefore the moist air cannot escape.

### How condensation occurs

Condensation occurs often for short periods in bathroom and kitchen areas because of the steamy atmosphere, and quite frequently for long periods in unheated areas; it also occurs in cupboards or corners of rooms where ventilation and movement of air is restricted.

### What is important

Two things are particularly important:

- To provide ventilation so that moist air can escape.
- To use the heating reasonably

### How can you prevent condensation

Provide ventilation so that moist air can escape.

- a) Good ventilation of kitchens when washing, cooking or drying damp clothes is essential. Use the electric element of the space heater will help, when washing, cooking, or drying damp clothes, and particularly when the windows show signs of misting up.
- b) If there is no mains electric supply and therefore you cannot use the electrical element of the space heater, open the skylights or windows slightly, but keep the door closed as much as possible.
- c) After showering, keep the bathroom window or skylights open, and shut the bathroom door long enough to dry off the room.
- d) In all other areas provide some ventilation. Fixed ventilation is provided in accordance with BS EN 721: 1998 this is through skylights and 'Heki roof lights' in the roofs and from ventilators through the floor under cookers, doors and in bed boxes it is important not to block these.

Too much ventilation in cold weather is uncomfortable and wastes heat. All that is needed is a very slightly opened window or skylights. Opening a skylight or 'Heki; rooflights partially or windows opened to about 1cm opening will usually be sufficient.

### Provide reasonable heating

- a) Do not use of portable paraffin or flueless gas heaters at all.
- b) If drying damp clothes or towels, open a window enough to ventilate the area and turn on the electric element of the space heater but do not hang items over the heater.
- c) Try to make sure that all areas are at least partially heated. Condensation most often occurs in unheated areas.

## EXTERIOR AND INTERIOR MAINTENANCE

- d) To prevent condensation, the heat has to keep room surfaces reasonably warm. It can take a long time for a cold caravan to warm up, so it is better to have a small amount of heat for a long period than a lot of heat for a short time.

Caravans use only carefully selected insulation materials but unlike most rooms at homes they have all outside walls, so they lose heat through all walls as well as the roof and floor.

Even in a well insulated Caravan with reasonable ventilation it is likely during cold weather if the temperature is less than 10°C that condensation will occur. Ideally the temperature should be kept about 20°C although this is not always possible.

### Mould growth

Any sign of mould growth is an indication of the presence of moisture and if caused by condensation gives warning that heating or ventilation, may require improving.

### New vehicles

New Caravans often take a long time before they are fully 'dried out' because of moisture in the materials used in the manufacture. While this is happening they need extra heat and ventilation. At least during the first winter trips and may require more heat than they will need in subsequent winters journeys. Allowance should be made for this.

**WARNING:** Do not wash your caravan with a high pressure washer as these can permanently damage the seals of your caravan.

### Changing Exterior Bulbs

ALWAYS REPLACE LIKE FOR LIKE

For individual replacement bulb specification, refer to your Service Handbook.

## CARAVAN INTERIOR

Follow these guidelines to ensure your investment is receiving the very best attention.

### Side Walls, Roof Lining

A simple wipe over with a damp cloth and a very mild detergent is all that is needed.

### Soft Furnishings

Should be vacuumed occasionally to remove grit and sand and help to keep its smart appearance and ensure long life. The upholstery can be cleaned with a mild, reputable upholstery cleaner. It is recommended that the curtains and pelmets are specialist cleaned only. The foam used in cushions is manufactured to meet fire regulations. It requires time to return to its normal position after prolonged use.

### Work Surfaces

You should not stand very hot items on any of the work surfaces, especially models with polycarbonate moulded sinks and drainers.

### Kitchen Equipment

All the thermoplastic parts in these areas have easy clean surfaces. To ensure long life and to prevent damage you must not use any cleaning materials at all and ensure water temperatures do not exceed 70°C (putting cold water in first is suggested). After every use it is essential that you rinse with clean water only and wipe with a soft damp cloth. Failure to follow these simple instructions may result in premature failure or cracking which will not be covered by any guarantees (including extended warranties).

### **Bathroom/Shower**

These products should be cleaned immediately after use. Apply a warm, mild soapy water solution with a soft cloth and rinse with clean water immediately. Abrasive materials must never be used. For stubborn stains "Thetford Bathroom Cleaner" is recommended as the use of other cleaners may harm these products, cause premature failure and will invalidate the warranty. "Thetford Bathroom Cleaner" is available from most caravan dealer shops.

### **Furniture**

A simple wipe over with a damp cloth should be all that is required. Polishing with a proprietary brand of wax polish enhances and maintains furniture in showroom condition.

It must be remembered that because the frames of the doors are made of ash, which is a natural product, they can be affected by temperature and humidity and may bow under certain conditions. As conditions change they should revert to their original positions.

### **Kitchen Drainer and Cutting Board**

You should not stand hot items on to the removable plastic kitchen drainer. To wash use only warm soapy water, do not use chemicals and bleach.

### **Changing interior bulbs**

Remove the lens or lampshade to access the bulb.

**ALWAYS REPLACE LIKE FOR LIKE**

For individual replacement bulb specification, refer to your Service Handbook.

### **Locker Header Fluorescent Tube Replacement**

- Ensure power supply to light is switched off.
- Open locker, light is mounted above. Locate fixing screws (orientated towards ceiling) and remove.
- In the case of a side locker, a small furniture component onto which the light fitting is secured can now be removed.
- In the case of an upper welsch dresser ( or similar), a larger component carrying all the lights from above that piece of furniture may detach.
- Once the appropriate light fitting has been accessed, the tube should be twisted along its length to release the tube and allow it to be lifted from the fitting.
- Please see the bulb replacement chart for details of the type of tube fitted. In addition, different 'colour temperatures' of bulb are available. For a consistent appearance replace tubes with those of equivalent colour temperature: This will be stated on the fitted tube in the format '4200K' or similar.

## WINTERISATION

**WINTERISATION**

The Swift Group recommends the following winterisation points for customers:

**Servicing**

Arrange (in advance) the yearly service and habitation check, if the caravan's next service is due while the vehicle is stored.

**Plumbing (where tank is fitted)**

- Open the tank drain valve to drain the tank, and leave open.
- Open the safety drain valve (yellow handle) next to water heater, and leave open.
- Fully open all the taps and shower mixer, move mixer position to the middle, and leave all taps in the open position.
- Unscrew the shower head and shower hose, shake out remaining water and allow water to drain. It is advised to leave the shower head and hose disconnected.
- Run pump for a short time, until all water is expelled.
- Disconnect the inlet pipe to the onboard water pump, mesh filter and outlet pipe, and re-run the pump for a short time, to ensure all the water is removed. Leave the system disconnected during storage.
- Fit the cowl cover to the Truma Ultrastore (if fitted).
- Clean waste pipes and tanks using a sterilising fluid.

**Electrical**

If vehicle is being stored while connected to 230v Mains Hook-up:

- Ensure that the leisure battery is connected and the 20A local fuse(s) is connected.

- The isolator switch on PSU should be in the 'ON' position, however, the control panel should be switched 'OFF'.
- If Alde system is installed, there is a frost protection setting, which can be used.
- Vehicles can be left in this condition for extended periods, with the charger operating to maintain the battery. However, periodic maintenance and inspection is recommended, this should include the battery condition.

If vehicle is being stored not connected to 230v Mains Hook-up:

- Charge the leisure battery for 24 hours prior to placing caravan in storage.
- Ensure the isolation button on PSU is in the 'OFF' position.
- Ensure leisure battery is connected and 20A local fuse(s) is in place, if an alarm or tracker device is fitted.
- The alarm / tracking device will eventually drain the leisure battery - we recommend regular (monthly) inspection / re-charging of leisure battery via appropriate solar panel can be used to provide an alternative power source and extend the time between leisure battery requiring a re-charge.
- Remove the leisure battery and store in a dry place, if an alarm or tracker device is not fitted.
- The battery should not be adversely affected by winter temperatures but the level of charge should be maintained to maximise the life span of the battery. This can be achieved using an automotive type battery charger as and when required.

**Gas system**

- Ensure the gas supply is isolated at the gas bottle, and ensure that the gas manifold taps are off.
- Check the age and condition of the high pressure gas hose and regulator, and replace if required.

## Appliances

Check the battery expiry date on the smoke alarm and replace or remove as required.

- Ensure the fridge is turned off.
- Clean the inside of the fridge.
- Prop the fridge door open, and if possible, the internal freezer compartment door for ventilation.
- Fit fridge vent winter covers (if available).
- Ensure all hob / oven / microwave surfaces are clean.
- If the caravan is going to be left connected to 230v supply while not in use, ensure the microwave is unplugged.
- Drain the toilet reservoir.
- Empty the toilet cassette.
- Leave toilet caps removed and apply acid-free Vaseline or similar to the seals.
- Drain the toilet reservoir.
- Empty the toilet cassette - The Thetford Cassette porta potti is easily winterised for storage.

Empty the fresh water tank using the drain tube / fresh water tank level indicator (level indicator on electronic models only).

Pull the lever indicator / drain tube down from top plug position and outward through door opening to drain water from the tank.

Empty the water fill funnel by pulling the bottle away from tank.

Remove the small water cap on the filler bottom, allowing water to drain from the water funnel. (Not C-200 toilet).

Do not tighten caps, this helps in keeping unit dry. The pour out spout and vent plug can be removed. Seals should be greased if necessary with acid-free Vaseline.

## Exterior (Body / Chassis)

- Ensure that all windows, skylights and access doors are closed and secured.
- Ensure all fixed ventilation points (high and low) are clear from debris and obstructions.
- Ensure the vehicle is not parked where falling debris (i.e. leaves, tree sap) could cause damage.
- Avoid leaving the vehicle parked in soft ground, long grass or a potential area where standing water may form.
- Lubricate relevant points on the chassis.
- Remove road wheels, using the correct jacking points and suitable axle stands, or if being left on road wheels rotate wheels (every two weeks) and ensure the correct tyre pressures are maintained.
- A purpose made cover maybe used, but please ensure the cover is a good fit, breathable and securely fitted.  
**Note:** A poorly fitted cover can rub and damage the bodywork. Non-breathable covers will encourage mould to grow.

## Interior (Furniture / furnishings)

- Open all lockers and internal doors, to ensure good circulation.
- Remove cushions and store them in a dry location or ensure all cushions are placed in a well ventilated area.
- Close all blinds and curtains. Customers are reminded to check the tension on blinds after storage if left closed for long periods.
- Thoroughly ventilate the caravan by opening doors or windows periodically.
- Placing water absorbent crystals in the van during the winter months, will help reduce moisture levels and mould growth.
- We do not recommend leaving portable heaters in the van unattended.

# WINTERISATION

## Water system

Water expands as it is frozen, and so trapped water, when it expands, can damage the tap / valve / pump or pipe it is trapped within. For this reason, (in addition to reasons of hygiene), the water system should be fully drained when not in use, particularly in colder weather.

Follow the basic steps outlined below to remove water from the system (current caravans):

- Disconnect any external water source, external submersible hose or pump.
- Locate the 'Yellow' drain valve, which is floor mounted and will be next to the water heater. Move the lever on this valve to the vertical.
- If a water tank is fitted, open the tank drain valve located on the floor, next to the heater drain valve as above.
- Open one of the taps (the kitchen tap is the most convenient) to the middle (hot and cold mix) position.
- Turn on the pump using the button on the control panel, and leave the pump running until water no longer flows from the tap.
- Open the vanity tap and shower tap mixer, again to the centre hot and cold position and leave them open whilst the caravan is out of use.
- Also remove the shower head, and leave the head in an upright position.

After a short while the majority of water will have left the plumbing system. At this point however it is still important to ensure that the pump itself is 'dry'. During this part of the winterisation, a suitable absorbent cloth or container should be used to catch a small amount of spilled water that will result.

The pump should be disconnected on the output side of the pump, and run for a short while to expel any water contained within the pump body and filter. This is also a good time to dis-assemble and clean (if necessary) the filter fitted on the input side of the pump.

The easiest method of disconnecting the pump will vary depending on which manufacturers pump is fitted. The options are to unscrew the 'Beige' screw-fit adaptors from the pump inlet and outlet, remove the quick-release tabs from the Posi-flo type pump, or remove the 'Blue' pipe work from the push fit plumbing connections. (Details of releasing push fit plumbing connections can be found later in this document).

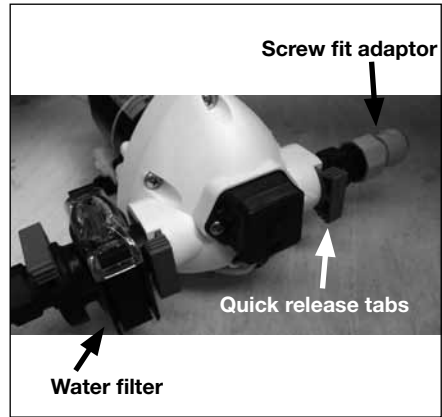

## Galvanised Parts - Wet storage stain (white rust)

Hot dip galvanising has been used for many years throughout the automotive industry and is widely regarded as one of the best forms of corrosion protection.

When the steel is withdrawn from the galvanising bath it has a clean, bright surface. Over a period of time this changes to a dull grey colour as the surface zinc reacts with oxygen, water and carbon dioxide in the atmosphere to form a tough, stable, protective layer.

During this time, if galvanised items are stored in damp or wet conditions, where there is little or no air movement then the zinc will continue to react with the moisture that is present. In so doing the zinc will produce excessive amounts of zinc hydroxide. This is seen as a bulky white deposit on the surface of the galvanising and is often referred to as wet storage stain (white rust).

In order to prevent the occurrence of wet storage stain in the first instance, and to allow the final protective layer to form correctly it is important to ensure that all galvanised parts are stored in good conditions, with sufficient ventilation to allow good air circulation.

In the case of caravans, you can help to prevent wet storage stain (white rust) occurring. You can do this by washing the chassis with clean water. You must then allow an adequate flow of dry air to ensure that they dry off completely.

The caravan should not be parked on long grass where the air flow around the chassis is hindered and the dampness retained. It is most likely that the chassis will rapidly show signs of wet storage stain under these conditions.

It is also very important to do this during the winter months to ensure all salt deposits from road spray are completely rinsed off.

## CHASSIS

**AL-KO CHASSIS**

Manufactured from high quality steel, the chassis has extra deep sections to provide strength at points of maximum stress. Large elongated holes are punched in the longitudinal chassis members, to reduce weight to a minimum. Each hole incorporates a return flange to maintain the required strength and provide rigidity in the extra deep sections.

The chassis frame is of a bolted construction which allows replacement of individual parts should the need arise.

The chassis is Hot Dipped Galvanised. This is regarded as one of the best forms of corrosion protection. It does however require minimal maintenance in certain circumstances and should, if properly maintained, last the lifetime of the vehicle.

When new, the chassis is of a bright and shiny appearance. As the galvanising cures during the initial 2/3 month period, this will gradually change to a medium/dark grey colour. This grey finish is the ideal, giving the correct protective coating. During this curing period the surface should be protected to avoid possible wet storage stain, in the form of a soft, light coloured, porous, oxidation layer. If the chassis members are in contact with any salt deposits from roads this should immediately be washed off with a high pressure washer. Salt attracts moisture allowing the surfaces to remain wet, this prevents curing and also allows formation of wet storage stain.

It is recommended that the chassis/ components are washed off, using a pressure washer on an annual basis (especially after winter usage), to avoid undesirable build up of salt and dirt deposits.

The galvanised chassis should not be painted or subjected to any other protective treatment.

Should the galvanising become superficially damaged exposing the steel core, this should be cleaned and treated with a Cold Galvanising Spray obtainable from vehicle accessory outlets.

Damage to chassis members through impact etc, MUST NOT be straightened or welded. Damaged chassis members MUST be replaced.

**Drilling or Welding of Parts or Accessories**

The chassis is designed and built to precise tolerances and must not be drilled or welded (except in accordance with certain AL-KO Accessory Operating Instructions). Failure to comply will invalidate all warranties.

**AL-KO ATC TRAILER CONTROL SYSTEM**

AL-KO ATC is an electronic, emergency Control system for caravans and trailers. It automatically recognises critical swinging motions and applies the caravan brakes accordingly to regain control of the caravan and car.

**General notices**

Read and act in accordance with the following operating instructions before attempting to use AL-KO ATC. AL-KO ATC is a safety related product and, therefore, should only be fitted by an authorised AL-KO trained technician with experience of working with electrical installations. Any evidence of removal or disassembly, other than by trained technicians, will immediately invalidate the product warranty.

**Safety Information**

AL-KO ATC is a passive safety product that activates the braking system on the caravan in unsafe driving conditions. The driver has a responsibility under law to ensure that the elements of towing safety are met, including driving within the legal speed limit, consideration of road, weather and other traffic conditions, correct loading and coupling of the caravan.

AL-KO ATC is designed to fit only on AL-KO Chassis and is not suitable for non AL-KO Chassis. AL-KO ATC only functions on caravans with a rigid towbar. The electrical connection between the towing vehicle and caravan must be in good working order.

### System requirements

ATC draws power from the towing vehicle towbar and requires connection to either: Twin 7-Pin Connection - ATC can be connected via the auxiliary 12S (white/grey) plug and requires power on Pins 4 (permanent supply) and 3 (earth). Please ensure that your vehicle towbar is correctly connected to ensure correct ATC operation. This can be checked with the use of a multimeter. Important - A 20 amp fuse is required for the constant 12V supply to Pin 4 on the 12S socket. If only a single fuse is fitted to supply both Pins 4 and Pin 6, the power supply capability of the installation must be checked and a minimum fuse rating of 25 Amps must be used. 13 Pin Connection - ATC can be connected via the 13-Pin plug and requires power on Pins 9 (permanent supply) and 13 (earth). Please ensure that your vehicle towbar is correctly connected to ensure correct ATC operation. This can be checked with the use of a multimeter.

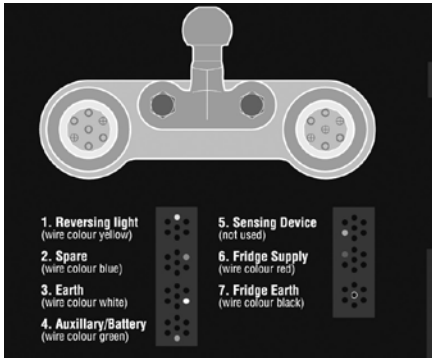

### Operating instructions

After coupling the caravan correctly to the towing vehicle, connect the 12N & 12S plugs or the 13 Pin plug to the towbar.

Upon connection, ATC will carry out an initial self test and the LED light on the front fairing will light up RED. During the self test, the sound of the push rod moving inside ATC can be heard. When the self test is complete, the LED will turn GREEN or flashing GREEN to signal that ATC is active. If the LED does not change to green, then ATC is not functioning correctly. The table provided on page 4 details

what to do in this case. Prior to commencing any journey, ensure that the caravan lighting is fully operational and check the vehicle is loaded appropriately, the nose weight and tyre pressures are correct, and confirm that the caravan is coupled to the vehicle with the breakaway cable correctly applied. Always re-check the ATC LED is green after any interval during a journey, such as a service station break.

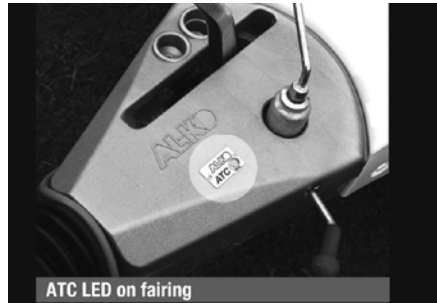

### Troubleshooting

Should you experience a fault with ATC, the LED light on the fairing will change colour. Therefore, refer to the table on page 4 and follow the instructions. If no illumination of the LED is evident, refer to system requirements on page 3 and check towbar wiring for permanent supply.

In the unlikely event that you receive a red flashing LED light and disconnecting and re-connecting the power does not alleviate the problem, check the push rod position as detailed below. Locate ATC on the axle and check the position of the push rod. If no red line is visible, ATC is not active, and can be driven. However, we recommend that you contact AL-KO at the earliest convenience.

If the red line is visible on the push rod, as shown on the left, the caravan should not be moved. The push rod needs to be removed to deactivate ATC. Using two 17mm spanners, the removal process is as shown opposite.

# AL-KO ATC CONTROL SYSTEM

Display Colour	ATC Condition	Diagnosis	What to do	Outcome	Status
Green	ATC Active	Everything Ok			
Green Flashing	ATC Active	Self test incomplete	Drive forward to detect movement to complete self test and recheck LED.	Green ( Constant)	Ready for journey
Red	ATC Inactive	Possible to continue journey	Remove 12S or 13 Pin plug and wait 5 seconds. Reconnect plug.	Green  Red	Ready for journey  ATC Error logfile memory exceeded. Caravan can be towed, but ATC will not apply caravan brakes in the event of instability. See below *
Red flashing	ATC has detected a fault.	Do not continue a fault with ATC connected	Remove 12S or 13 Pin plug and wait 5 seconds. Reconnect the plug	Green  Red (flashing)	Ready for journey  ATC faulty, and cannot be driven. Remove push-rod as shown on page 5. Consult AL-KO, see back page for details.
LED not working	ATC has no power	Check push rod position as shown LED faulty on page 5 before continuing journey.	Remove 12S or 13 Pin plug and wait 5 seconds. Reconnect the plug. Check for constant live - refer to system requirements.	Green  LED not working	Ready for journey  If power ok, check push rod position: Red line visible - do not drive vehicle. Red line not visible - possible to continue journey but consult AL-KO see back page for details.

\* ATC stores operating errors in a logfile which over time will become full and will result in the solid red light appearing. This needs to be erased and can be done easily by connecting the caravan to a 12 volt supply for a period of 12 hours. The power required to carry out this function is minimal. Most occurrences of these errors are due to power supply problems to ATC which could be due to low voltage, or an intermittent power supply from the towbar.

### Maintenance and Warranty

ATC is maintenance free and requires no servicing. In case of any damage to ATC, please contact AL-KO. ATC is a sealed unit and any evidence of removal of ATC or the component parts including outer casing and fixings will immediately invalidate any product warranty.

ATC is covered by a 12 month warranty where it is retrofitted to a caravan. If ATC is fitted as standard by the vehicle manufacturer then ATC is covered for the same duration of the vehicle warranty or whichever is longer. If ATC is subject to a call out under warranty and found to comply with the relevant specification or standard, then the cost of any testing or callout charges will be borne by the customer. We reserve the right to request credit card details to cover payment in advance.

### Removal of a push rod



**Using a 17mm spanner, slacken locking nut on push rod away from Bowden cable abutment as directed above.**



**Unscrew push rod from brake rod and slide it from the guide tube. Remove the locking nut from push rod using two 17mm spanners.**



**Re-apply the removed locking nut onto brake rod thread to secure ball nut as shown above. ATC is now deactivated.**

### The AL-KO formula optimum safety

The AL-KO formula for optimum safety is a combination of industry leading technology that ensures the safest possible driving conditions for caravan owners. The formula provides total confidence and control when towing a caravan.

CHASSIS



**ATC**

+



**AKS**

+



*Responsible  
Driving*

As an emergency system, AL-KO ATC automatically safeguards against a number of critical driving conditions. When used in conjunction with AL-KO AKS, there is no safer package for towing a caravan.

The AL-KO AKS Stabiliser device permanently suppresses small swinging and pitching movements in the trailer and increases the critical driving speed by approx 20%.

A safe driving style and correct loading combine with AL-KO technology to ensure optimum safety and unparalleled towing stability.

**Loadings on Coupling Heads, Overrun Assemblies and Axles**

The permitted 'nose' weights of the coupling head/stabiliser, overrun assembly and drawbars, must never exceed the lowest value stamped on the assemblies.



**Fig. 1**

The maximum axle loading is that stamped on the plate (Fig. 1 example axle plate) located in the centre of the axle, facing rearwards.

Do not attempt to remove as this will void the plate.

The third line down marked "Capacity" is the maximum permitted axle loading and must not be exceeded.

The caravan manufacturer may have stated a

lower maximum loading weight on the plate fitted adjacent to the entrance door, this then becomes the maximum permitted load and must not be exceeded. We recommend you record the Axle details for future reference.

It may be possible if required for the caravans MTPLM to be upgraded.

Your caravan dealer will require the following details from the axle plate.

(Example of information ref Fig 1)

- Order - CHA402248
- Qty - 1 of 2
- Date - 3 May 05
- Type - B850-10
- Capacity - 1000E

Please consult your Swift Group Dealer to confirm if this is possible.

## Loading

Loads to be carried in the caravan should be placed directly over, or as close as possible to the axles, otherwise the handling will be impaired. Maximum gross weight, as advised by the caravan manufacturer, must not be exceeded without approval from AL-KO.

Maximum loading is defined as the difference between ex-works weight and the permitted total weight.

### Load Too Far Forward (Fig 2)

Steering and braking ability reduced. Increased loading on the rear axle and chassis of the tow vehicle.

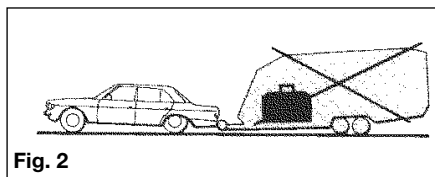

Fig. 2

### Load Too Far Back (Fig. 3)

High skid risk together with poor braking effect.

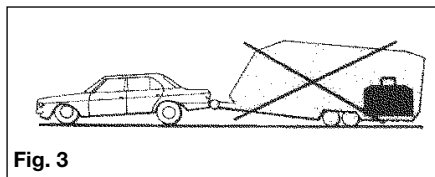

Fig. 3

### Load Over Axle (Fig 4)

Optimum road holding together with maximum braking effect. Exceptionally heavy loads should be placed directly over the axle.

Attention should be paid to the legal regulations regarding the permitted pressure exerted by the towbar on the towed unit.

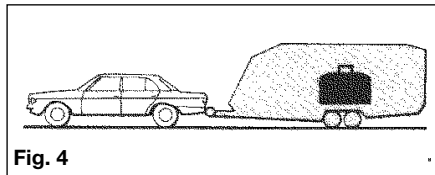

Fig. 4

## AXLE TYPES

### Safety Precautions

No welding is permitted on AL-KO Axles

It is important that the wheel and hub/ brake drum are compatible. This means that the PCD, wheelbolts and inset must all be compatible with both the hub/brake drum and the wheel rim.

Particular attention must be paid to the recommended torque figures for the wheelbolts (see pg 31).

The axle type details shown on axle type plates must not be obscured or made illegible by application of any additional surface finish.

## OPERATING INSTRUCTIONS

### Service Brake

When the towing vehicle is braking or travelling down hill, the overrun device shaft is pushed in (dependent on the magnitude of the thrust on the shaft) and presses on the overrun lever. This acts on the bowden cables and expander mechanism, which in turn expands the brake shoes applying the wheel brakes.

### Hand brake

With the gas strut version, pull the handbrake lever until upright. With the spring cylinder version, pull the handbrake lever right up to the last tooth. The caravan is then braked.

### IMPORTANT NOTE

**Please note that with the handbrake fully applied, the caravan/trailer is able to move backwards by 25 cms until the spring cylinder/gas spring takes effect.**

### Maintenance and Cleaning

Maintenance of Euro-Plus/Euro-Compact and Euro-Delta.

The above semi-trailing axles come fitted with maintenance free wheel bearings (greased and sealed for life) and no adjustment is necessary.

**Note:** The hub bearing is not protected against water ingress. Check wheel brake

## CHASSIS

linings for wear every 10,000 kilometers (6200 miles) or every 12 months via the inspection hole

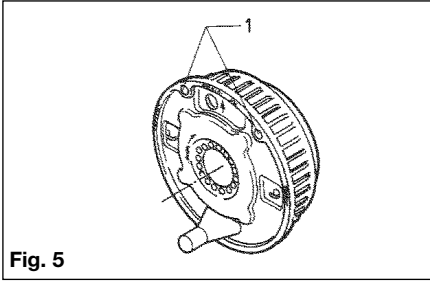

(Fig. 5/Item 1). Adjust if necessary. Where continuous travel in hilly regions or high mileage is experienced, earlier inspection and adjustment may be necessary.

**NOTE:** The flanged hub-nut, located under the dust cap, used to keep the brake drum in situ, is a ONE-SHOT NUT (ie. must only be used once). If removed it must be replaced with a NEW flanged nut - torqued to  $290 \pm 10$  Nm ( $214 \pm 1$  7.5 lbs/ft). A small amount of special mineral grease, available from AL-KO must be applied to stub axle thread prior to fitting the new flanged nut. After fitting excess grease must be removed with white spirit.

The rear hexagon cap head bolt located under the black plastic cap **MUST NOT BE DISTURBED** under any circumstance. Interference with this nut will result in immediate tyre wear and damage to the braking system and **WILL INVALIDATE ALL WARRANTIES**. Should the rear nut accidentally be disturbed then the complete axle must be returned to AL-KO for resetting of the toe-in and camber.

No attempt should be made to remove the bearing. In the event of damage to the bearing or drum, only the drum complete with bearing and circlip will be available as a spare. No grease is used in the hub other than the mineral grease on the stub axle. No grease should be placed in the DUST cap. This is not a grease cap as used in all previous hubs

### Spare parts

Spare parts are safety critical parts! For this reason when fitting spare parts we recommend the use of original AL-KO parts or those parts that they have explicitly approved. The reliability, safety and suitability of parts designed especially for their products, has been determined using a special test procedure. In spite of constantly monitoring the market they are unable to assess or vouch for other products.

If repair work or servicing is required, AL-KO have a large network of AL-KO service stations throughout Europe.

To establish the correct spare parts required for your axle you should always quote the axle type (axle identification plate Fig. 1, page 172) and Spare Part Identification no. (ETI No.), which will be stamped onto the wheel brake or on the identification plate (Fig. 6). Please establish these numbers before contacting AL-KO or a Service Agent.

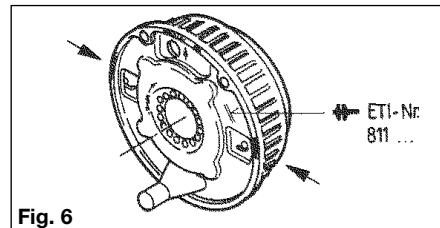

The AL-KO rubber suspension axle has been designed and developed to suit all types of road conditions and is maintenance free.

Three rubber elements are contained within an hexagonal axle tube. These provide suspension and have inherent damping characteristics.

Figs. 7, 8 & 9 show the deformation of the rubber elements at the extremes of suspension movement.

The axle is designed to ride with the suspension drop arm at, or slightly below, the horizontal position.

For Trouble Shooting & Fault Finding please see Table 1 on page 186-187.

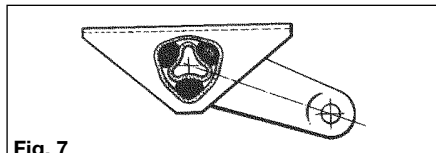

**Fig. 7**

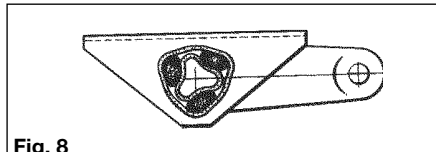

**Fig. 8**

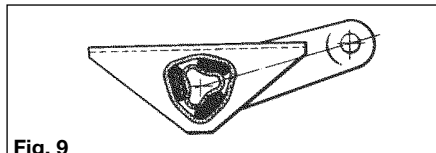

**Fig. 9**

### AL-KO braking system adjustment

1. Ensure the towing shaft with coupling head is pulled FULLY FORWARD. (Fig. 10).
2. Release the handbrake to the FULLY OFF position. If the handbrake will not go down the whole way because of the fairing or any other obstruction; then the fairing must be cut away and/or the obstruction removed to achieve this desired position. It will not be possible to set up the braking system properly when the handbrake is not in the FULLY OFF position. (Fig. 10).
3. Jack up one side of the caravan, using the AL-KO Side Lift Jack System. (see Jack Operating Instructions).
4. Remove the inner plastic bung from the backplate to expose the "starwheel" adjuster access. (Figs. 10 & 11).
5. ALWAYS rotating the road wheel in the forward direction - NEVER backwards; adjust the starwheel with a suitable screwdriver, in the direction of the arrow embossed on the backplate until there is resistance in the wheel rotation. (Fig. 11).
6. Slacken off the starwheel adjuster until the road wheel turns freely in the FORWARD direction. (Fig. 11).
7. Check the adjustment at the end of the brake cable where it is secured to the abutment (bracket), welded to the centre of the axle.  
  
When the inner cable is pulled out it should extend between 5 and 8 mm. (Fig.12). (On tandem axles a double abutment (bracket) is fitted to the front axle ONLY).
8. Repeat for other wheel or wheels.
9. On tandem axles the brake cables from the rear axle should pass over this axle and cross over each other, before being connected to the abutment (bracket) on the front axle.
10. Ensure the balance bar (compensator) is being pulled evenly (Figs.10 & 12). Excessive movement to this bar (double on tandem axles) would indicate possible incorrect adjustment (if appropriate, repeat step No. 7 - Fig. 12).
11. Check the brake rod support bracket, (fixed to the floor) IS supporting the brake rod evenly. The brake rod MUST ALWAYS run straight, NEVER bent or curved under any fittings. On tandem axles, using the double balance bar, a brake rod support tube ( ALKO Part No. 228827) MUST ALWAYS be fitted on the end of the brake rod, passing through the centre aperture on the abutment.
12. Remove the slack in the brake rod by adjusting the long ball nut, rear of the balance bar, ensuring the overrun lever makes contact with the end of the towing shaft. Note! Over adjustment to the long ball nut (Fig. 12/Item 2) could induce movement of the inner brake cable, reducing the effective clearance of the brake shoes. If the overrun lever will not make contact, it is possible the two lock nuts, forward of the spring cylinder, are incorrectly adjusted. Loosen the nuts and adjust brake rod as above (Figs. 10 & 12).

13. Adjust the two locking nuts, forward of the spring cylinder (Fig. 10), (on some chassis a single Nyloc nut is used) to give 1 mm of clearance on the spring cylinder. This cylinder (the energy store for the handbrake operation) must be able to rotate ONLY, not slide on the brake rod. (Fig. 12). **(If the overrun assembly is fitted with a gas strut handbrake then no spring cylinder is fitted - therefore ignore this paragraph).**
14. CORRECT ADJUSTMENT of the linkage is checked by operating the handbrake lever so that when the second or third tooth is engaged, a slight braking force is felt on the road wheels.
15. OVER ADJUSTMENT of either the wheel brakes or linkages, will result in difficult reversing causing the wheels to "lock-up".
16. When parking, the handbrake lever MUST ALWAYS be engaged into the fully upright position (90°). This is to compress the spring within the spring cylinder and thereby create an energy store which will automatically engage the brakes further should the caravan move. If difficulty is experienced in this operation, try easing the caravan backwards with one hand while engaging the handbrake fully with the other. This manoeuvre should not be attempted on a rearwards facing slope. In this case wheel chocks should be used combined with the handbrake. See page 25 for all handbrake operations.
17. Finally, if the road wheels have been removed, re-tighten using a calibrated Torque Wrench to 88 Nm (65 lbs/ft) - on all M12 wheel bolts and steel wheels or 96lbs/ft (130nm) for alloy wheels. Remember to over-tighten is just as dangerous as to under-tighten, as this can distort the wheel rims. Avoid the use of power wrenches.

IMPORTANT - The torque settings should be rechecked regularly. Wheel bolts should NEVER be lubricated.

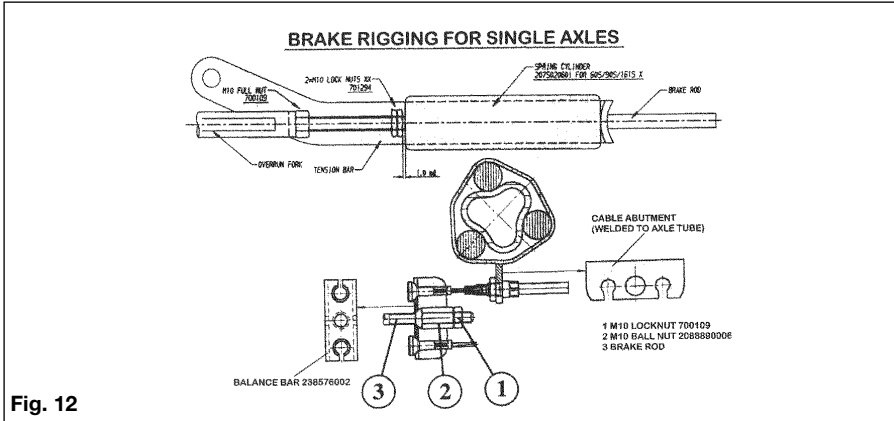
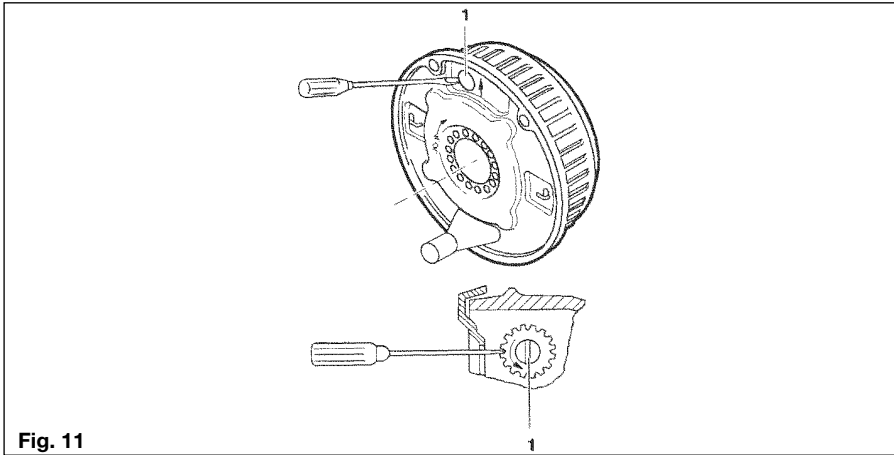
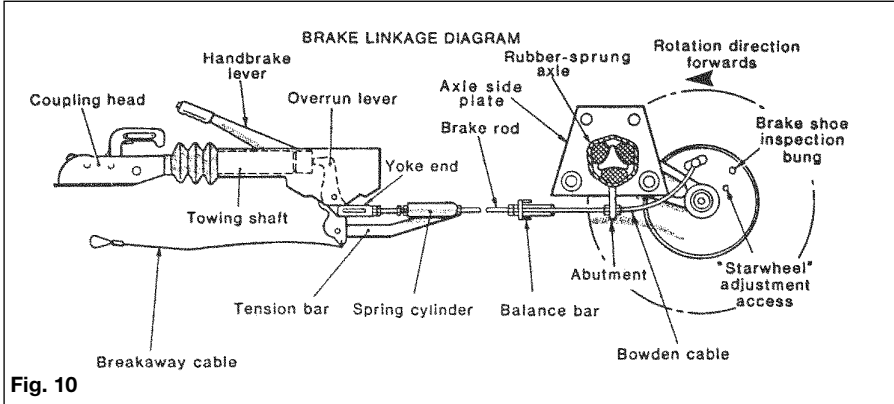

## OPERATING INSTRUCTIONS FOR AKS 3004

### Regulations

1. The AKS 3004 must be used in conjunction with 50 mm dia. towballs which conform to EC Directive 94/20 (DIN 74058 or local equivalent).
2. Suitable for attachment to drawbars or approved overrun braking equipment for single (and tandem axle) caravan/trailers, with a minimum weight of 200 Kg and a maximum permissible weight of 2000 Kg.
3. EC design approval has been given to the AL-KO AKS 3004 coupling under permit No. e1\*94/20\*0930\*00.

### Restrictions of use

1. The trailer coupling may only be connected to towing vehicles where the clearances for the stabiliser can be observed, in accordance with EC Directive 94/20 (DIN 74058). If these clearances are infringed by special attachments, then the use must be checked separately.

### Clearances for Stabiliser Handle (Fig. 19)

The area above the towball of the vehicle must be free from vehicle components or attachments (A) (eg. spare wheels, platforms etc.)

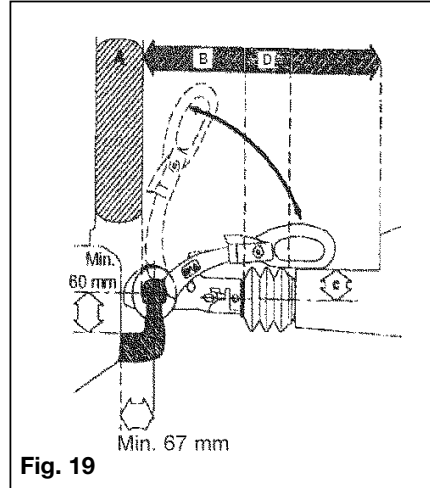

**Fig. 19**

The clearance for the stabiliser handle must be at least 330 mm (B) + the stroke movement (D) (85mm-100mm), which equates to 440 mm when used in conjunction with an AL-KO overrun.

Max. 50 mm (C) clearance between the centre of the towball and top of the overrun assembly or fairing, to ensure both coupling handle and stabiliser handle do not foul on operation.

Maintain the same clearances for other manufacturers' overrun assemblies.

2. Not suitable for use with overrun devices which can revolve above 25° (Fig. 20).
3. Swan Neck towbars (fixed or detachable) are suitable for use with the AKS 3004 providing they comply to EC Directive 94/20 and have the required minimum 60 mm clearance, measured from the centre of the towball (Fig. 20).

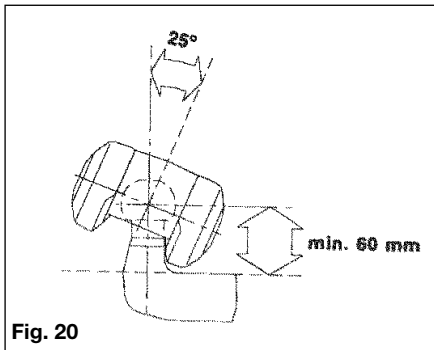

**Safety warnings**

1. In accordance with EC Directive 94/20, couplings of type A 50-1 cannot be used (see Fig. 21), your warranty will be invalid if this type of towball is used.
2. For UK use, please use the extended neck towball (type A50-X).
3. A bolted-in type ball coupling (Fig. 22) is only permissible if the thread is locked or welded.

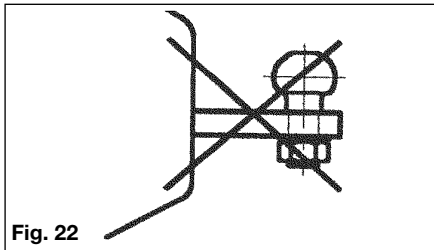
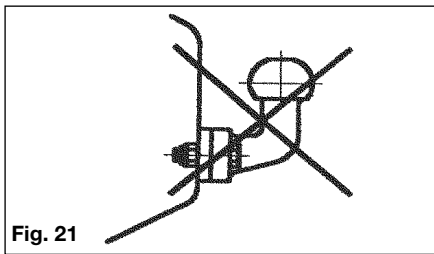

4. The AKS 3004 cannot be used with a laterally attached reversing lever, on the left side, when facing direction of traffic.
5. The towball must be free from grease, paint and other residue, otherwise the stabilising effect will be greatly reduced.
6. If friction pads become contaminated with grease, they should be replaced.
7. The AKS 3004 should only be operated by one person, when opening or closing the handle, to reduce injury risks.

**AKS 3004 DELIVERY SPECIFICATIONS**

Coupling handle (Fig. 23/Item 1),

Stabiliser Lever (Fig. 23/Item 2)

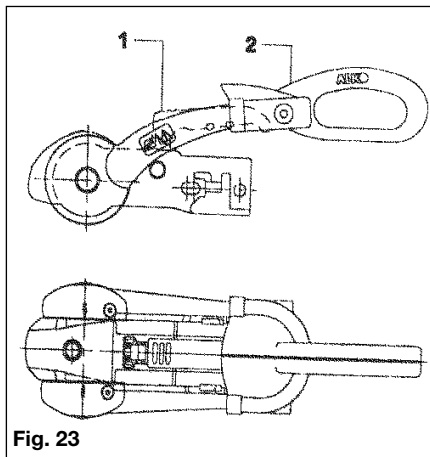

**Preparation for coupling/uncoupling**

The Stabiliser lever (Fig. 24/Item 2) must be in the uppermost position (open).

HITCH

**Coupling**

Pull the coupling handle (Fig. 25/Item 1) up in the direction of arrow. The coupling mechanism has an open position ie. as long as the AKS 3004 is not placed on the ball, the handle will remain open. Put the opened coupling onto the clean towball. The handle must now make an audible click and return to the flat position.

**Coupling Up (Euro-Overrun Devices)**

Fully retract Jockey Wheel inner tube so that it locks against Jockey Wheel outer tube.

Slacken Jockey Wheel Clamp handle and raise complete assembly through cutout in body to its highest position (ensure it doesn't come into contact with the brake rod assembly), fully tighten Jockey Wheel Clamp handle to ensure the Jockey Wheel is firmly held in position.

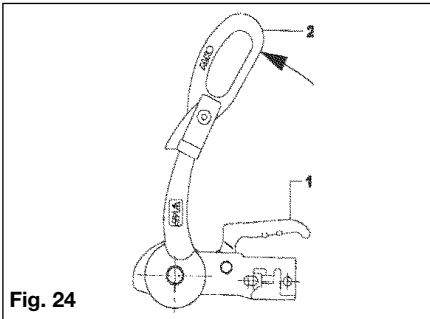

**Fig. 24**

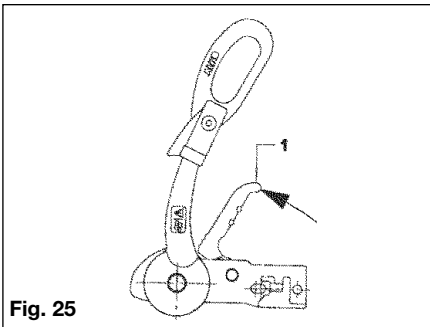

**Fig. 25**

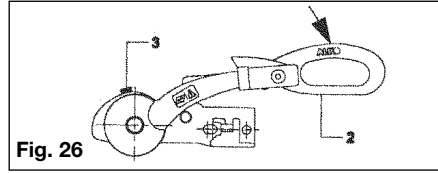

**Fig. 26**

**WARNING:** The coupling is correctly engaged when the green edge of the safety indicator button is visible or pops out (Fig. 26/Item 3).

**Stabiliser Unit**

To operate the Stabiliser (once coupled to the towball), simply press the stabiliser lever down as far as it will go (Fig. 26/Item 2).

**Uncoupling**

Pull the stabiliser lever handle up as far as it will go, open the coupling handle and lift the AKS 3004 from the towball. With larger nose loads, coupling and uncoupling can be made easier by using the jockey wheel to assist lifting.

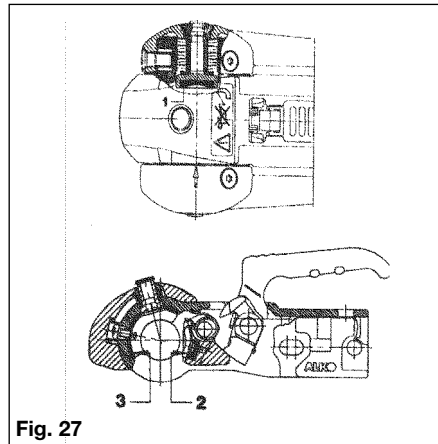

**Fig. 27**

**Please Note:** The friction pads (Fig. 27/1,2,3) are pressed against the towball and hence generate a stabilising/damping force. These pads are therefore subject to wear over time, however they will have a long service life (circa.30,000 Miles), provided they are well maintained and kept free of grease/dirt.

### Checking the efficiency of the left/right friction pads

1. Couple up AKS 3004.
2. Open Stabiliser lever (Fig. 28/Item1).
3. Close Stabiliser lever until resistance is felt (ie friction pads are in contact with the ball but not yet under pressure).

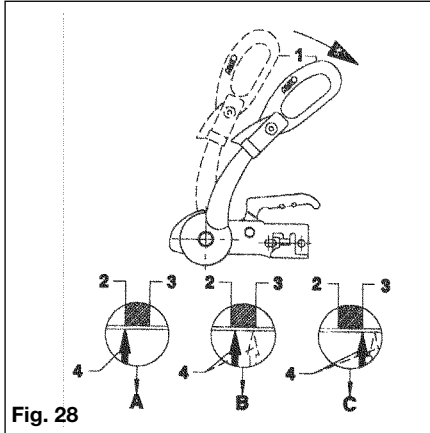

Fig. 28

4. If the arrow on the arm (Fig. 28/Item 4) is before or on the marked area (Fig. 28/Item 2) the friction pads are still as new (See A)
5. The arrow on the arm should lie between the marked area on the soft dock (See B)
6. If the arrow on the plate reaches or passes the marked area on the soft dock then the friction pads need replacing (See C).

Please Note: It is not necessary to adjust the friction pads

### Manoeuvring

For easier manoeuvring (on campsites etc), pull the stabiliser lever to the 'up' position.

Please do not use the stabiliser lever as a manoeuvring handle. Please use the handles on the Caravan or fit the AL-KO manoeuvring handle to your jockey wheel (available separately).

1. During opening or closing, the AKS must only be operated by one person.
2. Press stabiliser lever down by hand force only DO NOT use your foot or an extension bar, this will damage the components (Fig. 29).
3. When opening or closing the stabiliser lever, please ensure your hand does not touch the coupling handle - you may accidentally trap your fingers! (Fig. 29).

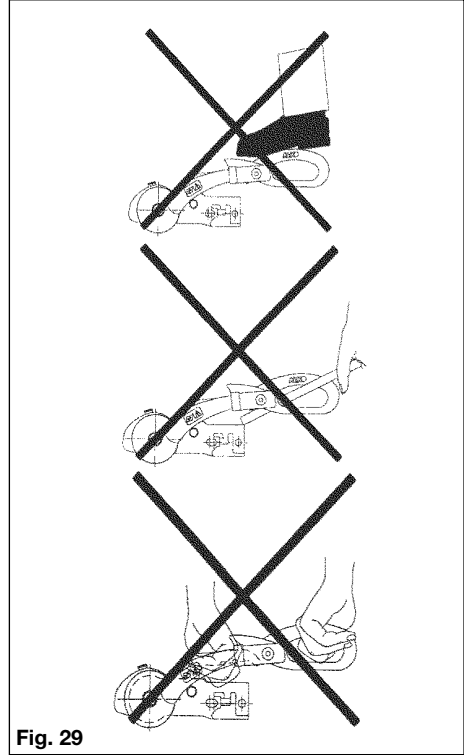

Fig. 29

# HITCH

## Noises whilst driving

As a rule, the friction pads of the AKS 3004 do not make a noise during driving. Any clicking, creaking or squeaking noises that do arise may be due to the following:

- a) Foreign bodies or dirt between the friction pad and tow ball.
- b) Dry operation of the draw shaft inside the overrun device.
- c) A detachable towball which has too much play in the locking mechanism.

## Remedial Action

- a) Clean the tow ball and friction pads by lightly rubbing the surface (100-120 grit emery paper).

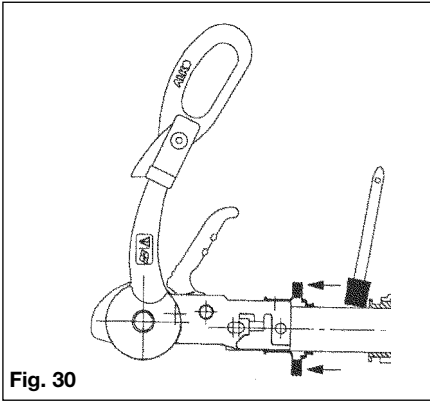

**Fig. 30**

- b) Lubricate the draw shaft sleeve via the grease nipples. In addition, push the gaiter forward and grease (DIN 51 825 KTA 3K) the exposed part of the shaft (Fig. 30).
- c) Visit a specialist workshop to have the ball holding area checked for damage and the locking mechanism for function. If necessary, change the towball.

## Servicing and Cleaning

Friction Pad Replacement (please replace one at a time)

1. Uncouple AKS 3004.
2. Remove protective caps (Fig. 31/Item 1) with the aid of a small screwdriver.

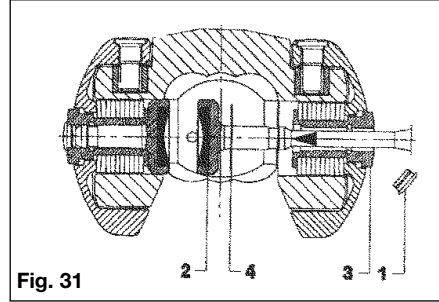

**Fig. 31**

3. Press worn out pad inwards and remove (use punch and hammer) (Fig. 31/2)
4. Insert new friction pad from below (after first re-inserting shim washers if they were present) and press in as far as it will go (Fig. 31/Item 4 & Fig. 32).



**Fig. 32**

### Checking the efficiency of the front/rear friction pads

1. Couple the AKS 3004 to the towball but do not activate the stabiliser.
2. If a green indicator is visible (on the handle), then the AKS 3004 is in a new condition or the pads and towball are within the permissible limits (Fig. 33/Item 2).
3. If only a red indicator is visible (Fig. 34/Item 3), then this may have the following causes:

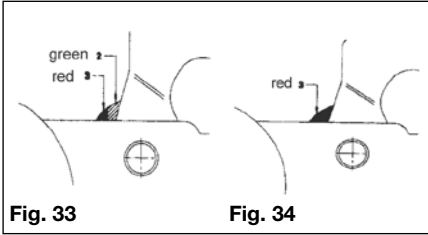

- a) AKS 3004 is okay but the towball has reached the lowest limit of 49.61mm
- b) AKS 3004 shows signs of wear
- c) Towball is in a new condition (50mm) but the front/rear friction pads show a high degree of wear.

Establish the diameter of the towball so that conclusions may be drawn as to the wear of the friction pads (ball diameter must not be less than 49.61mm)

### Friction Pad Replacement (Front/Rear only)

1. Uncouple the AKS 3004
2. Remove the rubber soft dock (pull up and off) Fig. 35/Item 1 & Fig 36.

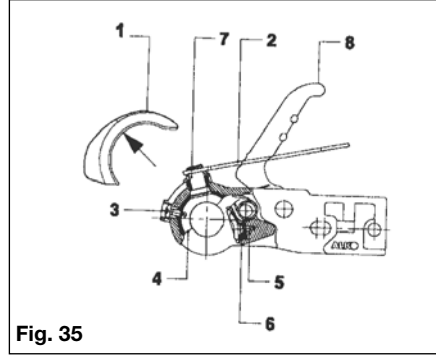

**Fig. 35**

3. Press the safety indicator outwards and secure with SW14 hex. spanner (not included), (Fig. 35/Item 2).
4. Remove cheese-head screws (Fig. 35/ item 3 & Fig 36), using special torx tool.



**Fig. 36**



**Fig. 37**

5. Press friction lining recess (Fig. 35/Item 4) inwards and pull down and out.
6. Open coupling handle (Fig. 35/Item 8).
7. Remove countersunk head cap screw using special torx tool (Fig. 35/Item 5 & Fig. 37).
8. Press friction pad inwards with a screwdriver and remove from ball cup.
9. Fitment of new linings takes place in reverse. Tighten screws 3 & 5 to 5 Nm.
10. Replace rubber soft dock, insert top section first then bottom.

# HITCH

## Important Maintenance and Cleaning Advice:

1. The towball should be cleaned regularly to remove grease or other residue, the use of Thinners, White Spirit or Brake Cleaner is recommended - otherwise the stabilising effect will be severely reduced.
2. If friction pads are contaminated, they should not be cleaned but replaced.
3. The surface of the towball must be free of grooves, rust or seizing marks.
4. Towballs coated (with paint or similar) must have this surface completely removed (use 100 or 120 grain emery paper). If this is not done, increased towball wear will occur and may cause damage to the AKS 3004 components.
5. In Winter, carefully spray only the visual indicator with de-icer.

## Lubrication

Should lubrication of the stabiliser parts become necessary, then the following must be observed.

- a) Clean all parts thoroughly.
- b) Areas may only be covered with a thin film of grease (Fig. 38).

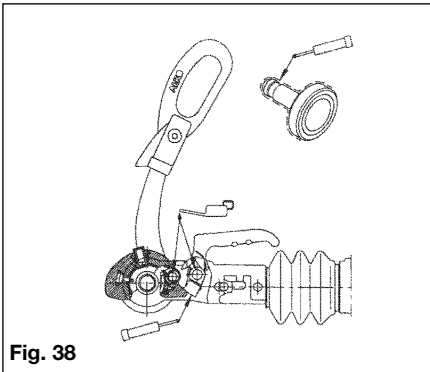

**Fig. 38**

- c) Use multipurpose grease DIN 51825 KTA 3K.

**WARNING:** When lubricating, ensure none gets into the friction pad or towball holding area.

## AL-KO secure immobiliser (model specific)

Refer to the User Instructions Kit supplied.

## Overrun Devices

In the importance of Safety, please familiarise yourself with the operation of this overrun device BEFORE using your caravan/trailer.

## Safety Precautions

When parking your tow vehicle and caravan/trailer on site, you must apply the caravan handbrake. If the unit is parked but disconnected from the tow vehicle, it is strongly recommended that each wheel is chocked using AL-KO or suitable wheel chocks.

If a 'detachable' type drawbar is fitted (as with catering trailers), the drawbar must not be removed from the trailer with the hand-brake applied.

**Caution: Please note when parking the caravan/ trailer, the wheelbrake auto-reverse mechanism will allow the caravan/trailer to travel backwards for approximately 25 cm (please allow sufficient clearance when parking).**

## Operation

AL-KO overrun devices are a mechanical type, using a hydraulic damper.

### Coupling Up

Manoeuvre towing vehicle or trailer to coupling point.

Overrun devices fitted with 50 mm coupling head

Fully open coupling head handle and secure hitch onto the towball. See page 25 (coupling up).

Thread the breakaway cable through the breakaway cable guide provided (Fig. 40) and connect it to attachment point provided on towing bracket (Fig. 39). Please refer to 'Braked Trailers Use of Breakaway Cables' for further detail.

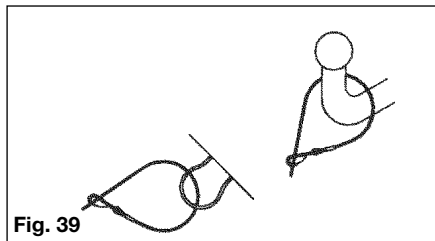

Fig. 39

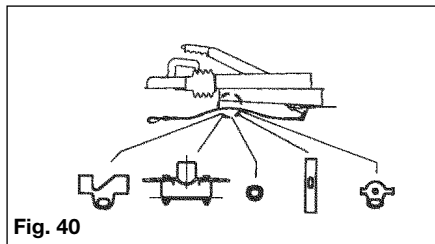

Fig. 40

**Caution: The breakaway cable operates the handbrake (emergency brake), in the event of the caravan/trailer becoming detached from the towing vehicle during towing. For this emergency brake to work correctly, it is absolutely essential that the following points are observed:**

1. The breakaway cable MUST run through the breakaway cable guide.
2. The breakaway cable MUST NOT be wrapped around the jockey wheel, as this disables the emergency brake (Fig. 41).

3. The cable MUST run as straight as possible and not be restricted.
4. Ensure the cable is long enough to allow for cornering and will not become taut or snag during use, as this could result in the handbrake operating whilst towing.

Please refer to 'Braked Trailers Use of Breakaway Cables' Information sheet, supplied with your caravan/trailer.

## TROUBLE SHOOTING & FAULT FINDING

**Table 1 Axles**

<b>Fault</b>	<b>Cause</b>	<b>Remedy</b>
Poor Braking	Linings worn or damaged. Brake Linings not bedded in. Brake set up incorrect.	Replace Brake Linings. Will pass after braking a few times. Reset Brakes as page 175 & ensure system is lubricated.
Difficulty in Reversing	Braking system set too tightly. Auto-Reverse lever too stiff.	Reset Brakes as page 175. Lubricate and free off Reverse Lever.
Brakes Overheating	Incorrect setting. Braking system not fully released. Overrun lever stuck. Damage or Corrosion to braking system	Reset Brakes as page 175. Check Handbrake has been released & the system is running freely. Lubricate and free off Reverse Lever. Check system as page 175 and repair or renew parts as necessary.
Handbrake Force Low	Incorrect setting of the brakes. Linings not bedded in.	Reset brakes as page 175 and lubricate as necessary. Will pass after braking a few times.
Uncomfortable ride or Uneven Braking	Loose braking adjustment. Damper defective. Axle shock absorbers defective.	Reset brakes as page 175. Check and replace damper if necessary. Replace shock absorber.

## TROUBLE SHOOTING & FAULT FINDING

**Table 1 Axles**

<b>Fault</b>	<b>Cause</b>	<b>Remedy</b>
Poor Braking	Linings worn or damaged. Brake Linings not bedded in. Brake set up incorrect.	Replace Brake Linings. Will pass after braking a few times. Reset Brakes as page 175 & ensure system is lubricated.
Difficulty in Reversing	Braking system set too tightly. Auto-Reverse lever too stiff.	Reset Brakes as page 175. Lubricate and free off Reverse Lever.
Brakes Overheating	Incorrect setting. Braking system not fully released. Overrun lever stuck. Damage or Corrosion to braking system	Reset Brakes as page 175. Check Handbrake has been released & the system is running freely. Lubricate and free off Reverse Lever. Check system as page 175 and repair or renew parts as necessary.
Handbrake Force Low	Incorrect setting of the brakes. Linings not bedded in.	Reset brakes as page 175 and lubricate as necessary. Will pass after braking a few times.
Uncomfortable ride or Uneven Braking	Loose braking adjustment. Damper defective. Axle shock absorbers defective.	Reset brakes as page 175. Check and replace damper if necessary. Replace shock absorber.

## CHASSIS TROUBLE SHOOTING

**Table 2 Coupling Heads**

<b>Fault</b>	<b>Cause</b>	<b>Remedy</b>
Coupling does not engage onto ball	Ball diameter too large. Ball could be damaged or deformed. Coupling head dirty or defective.	Change ball to correct size. Fit new ball. Clean & Lubricate coupling and replace if necessary.
Difficulty in Uncoupling	Ball damaged or deformed. Coupling damaged or deformed. Coupling head under pressure from damper.	Fit new ball. Replace if necessary. Pull forward a few inches to relieve pressure
Too much play in the coupling	Coupling damaged or deformed Ball too small	Replace if necessary. Fit new ball.

**Table 3 Overrun Devices**

<b>Fault</b>	<b>Cause</b>	<b>Remedy</b>
Poor Braking	Overrun shaft tight. Overrun shaft corroded. Body housing damaged.	Lubricate overrun shaft and replace any damaged parts.
Brakes Overheating During Towing	Handbrake not fully released. Braking system incorrectly set. Incorrect attachment of breakaway cable.	Release handbrake. Reset brakes as page 175. Ensure correct attachment as listed on page 22 or refer to Braked Trailers Use of Breakaway Cables sheet.
Handbrake Force Low	Defective gas strut. Incorrect setting of spring cylinder.	Replace gas strut. Reset spring cylinder as page 175.
Brakes Apply During Deceleration or Downhill Travel.	Overrun damper is defective.	Replace the overrun damper.

## ACCESSORIES

### Corner Steadies

Corner Steadies are as stated, for the purpose of steadying the caravan corners. They are **NOT JACKS AND SHOULD NEVER BE USED AS SUCH**. The screw and pivot pins should be lubricated periodically to ensure their satisfactory operation. (See also Jack Operation).

### Shock Absorbers

All AL-KO chassis have pre-punched holes to accommodate Shock Absorbers, in front of the axle. On the Euro-Axle System, axle swing arms have a removable rectangular plastic cap exposing a slot to accommodate retro-fit brackets for the Octagon Shock Absorbers. Delta Axles have Shock Absorbers fitted as standard which **MUST NOT BE REMOVED**.

### Road Wheels

In most instances the road wheels and tyres are supplied by the Caravan Manufacturer. The condition of wheels and tyres should be checked regularly, particularly for distortion of flanges and the wheel dish. Wheels that are damaged or distorted, or have wheel bolt seatings cracked or deformed must not be repaired or used in service - these must be replaced.

Important: Standard AL-KO caravan chassis use M12 wheel bolts. These must always only be tightened to the correct torque setting:

- Steel wheels 88 Nm (65 lbs/ft)
- Alloy wheels 130 Nm (96 lbs/ft)

in sequence, (i.e. North, South, East, West); **NEVER** clock or anti-clockwise. **ALWAYS** use a calibrated torque wrench, do not use a corner steady brace, power or electric wrench. It is as dangerous to overtighten wheel bolts as it is to not tighten them sufficiently.

**Important: The torque settings should be re-checked regularly.**

If other wheel bolts are used please ensure the torque settings are as follows:

M10 - 49 Nm (36 ft. lb)

M14 - 135 Nm (99.5 ft. lb)

M16 - 210 Nm (155 ft. lb)

### Special Note -Aluminium Wheels

For aluminium wheels use M12 x 1.5 pitch 26mm thread length 10.9 Grade 60° conical fixing.

The standard M12 x 1.5 60° Conical Wheel bolts are **NOT SUITABLE** for aluminium wheel rims. Special wheel bolts should be used.

### Jacks

The Corner Steadies Should never be used to jack up the caravan. When jacking becomes necessary use the AL-KO Side Lift Jack or 2-Tonne Jack system.

**NOTE:** It is essential that the car and caravan are hitched together before commencing jacking. All AL-KO chassis from 1992 onwards have 2 holes punched in the chassis members, each side (rear of the axle); to accept the brackets for the Jack(s). (

Corner Steadies may be used for stability **ONLY**, when the caravan is in the jacked position.

The caravan should never be lifted by jacking up under the chassis member.

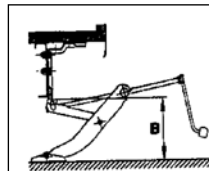

Side Lift Jack

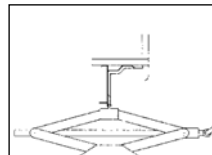

2 Tonne Jack

If working under the caravan in an elevated position, axle stands must be used for safety. Wheel chocks for the opposite wheel(s) are also advisable.

## CHASSIS MAINTENANCE

**Jockey Wheel**

Lubricate screw thread and wheel spindle periodically.

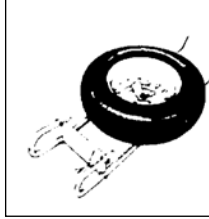
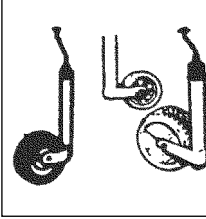
**Spare Wheel Carriers**

The telescopic frame tubes should be lubricated periodically.