



**The Hallmark of Excellence**

Sterling Caravans, Dunswell Road,  
Cottingham, East Yorkshire HU16 4JX.  
Tel: 01482 875740  
Fax: 01482 840082  
email: [enquiry@swiftleisure.co.uk](mailto:enquiry@swiftleisure.co.uk)  
website: [www.sterlingcaravans.co.uk](http://www.sterlingcaravans.co.uk)

A MEMBER OF THE SWIFT GROUP

1079647 issued November 2007



Elite

# Specification, Wiring Diagrams & Bulb Chart



# CONTENTS

|   |    |
|---|----|
| Specification .....                               | 1  |
| Wiring Diagrams                                   |    |
| Road Lights .....                                 | 2  |
| Consumer Circuits - Roof .....                    | 3  |
| Consumer Circuits - Floor .....                   | 4  |
| Power Circuits .....                              | 5  |
| 230V Circuits .....                               | 6  |
| Consumer Circuits – Floor with Alde Heating ..... | 7  |
| 230V Circuits – Floor with Alde Heating .....     | 8  |
| Cable Colour Chart .....                          | 8  |
| Bulb Replacement .....                            | 10 |

# Specifications

|   | ELITE DIAMOND              | ELITE EMERALD              | ELITE ONYX                | ELITE SEARCHER            | ELITE EXPLORER            |
|---|----------------------------|----------------------------|---------------------------|---------------------------|---------------------------|
| Berths  | 2                          | 4                          | 4                         | 4                         | 4                         |
| Axles   | 1                          | 1                          | 1                         | 2                         | 2                         |
| Internal Length (bed box height)                    | 4.74m/15'7"                | 5.50m/18'1"                | 5.50m/18'1"               | 6.27m/20'7"               | 6.27m/20'7"               |
| Overall Width                                       | 2.29m/7'6"                 | 2.29m/7'6"                 | 2.29m/7'6"                | 2.29m/7'6"                | 2.29m/7'6"                |
| Overall Height (inc. TV Aerial)                     | 2.70m/8'10"                | 2.70m/8'10"                | 2.70m/8'10"               | 2.70m/8'10"               | 2.70m/8'10"               |
| Maximum Internal Headroom                           | 1.95m/6'5"                 | 1.95m/6'5"                 | 1.95m/6'5"                | 1.95m/6'5"                | 1.95m/6'5"                |
| Overall Length                                      | 6.42m/21'1"                | 7.18m/23'7"                | 7.18m/23'7"               | 7.95m/26'1"               | 7.95m/26'1"               |
| Mass in Running Order (inc. tolerance)              | 1210kg/23.8cwt             | 1390kg/27.4cwt             | 1353kg/26.6cwt            | 1532kg/30.2cwt            | 1532kg/30.2cwt            |
| Essential Habitation Equipment Payload              | 105kg/2.1cwt               | 105kg/2.1cwt               | 105kg/2.1cwt              | 104kg/2.0cwt              | 104kg/2.0cwt              |
| Personal Effects Payload                            | 105kg/2.1cwt               | 133kg/2.6cwt               | 133kg/2.6cwt              | 141kg/2.8cwt              | 141kg/2.8cwt              |
| Optional Equipment Payload                          | 4kg/0.1cwt                 | 4kg/0.1cwt                 | 9kg/0.2cwt                | 38kg/0.7cwt               | 38kg/0.7cwt               |
| Total user Payload                                  | 214kg/4.3cwt               | 242kg/4.8cwt               | 247kg/4.9cwt              | 283kg/5.5cwt              | 283kg/5.5cwt              |
| Maximum Technical Permissible Laden Mass (DECLARED) | 1424kg/28.1cwt             | 1632kg/32.2cwt             | 1600kg/31.5cwt            | 1815kg/35.7cwt            | 1815kg/35.7cwt            |
| Maximum Technical Permissible Laden Mass (POSSIBLE) | 1500kg/29.5cwt             | 1750kg/34.4cwt             | 1600kg/31.5cwt            | 1900kg/37.4cwt            | 1900kg/37.4cwt            |
| Awning A/A dimension <sup>†</sup>                   | 9.11m/29'11"               | 9.87m/32'5"                | 9.87m/32'5"               | 10.64m/34'11"             | 10.64m/34'11"             |
| Tyre Size   | 175 r14 99                 | 195/70 r15 104             | 205/65 r15 102            | 175/65 r14 86             | 175/65 r14 86             |
| Tyre pressure at DECLARED MTPLM                     | 62psi                      | 60psi                      | 52psi                     | 40psi                     | 40psi                     |
| Tyre pressure at POSSIBLE MTPLM                     | 65psi                      | 65psi                      | 52psi                     | 44psi                     | 44psi                     |
| Static Load on Coupling Head                        | 100kg                      | 100kg                      | 100kg                     | 100kg                     | 100kg                     |
| Thermal Insulation Grade                            | TWO                        | TWO                        | TWO                       | TWO                       | TWO                       |
| <b>Bed Sizes</b>                                    |                            |                            |                           |                           |                           |
| Front Double  | 213cm x 180cm/7'0" x 5'11" | 213cm x 180cm/7'0" x 5'11" | 213 x 159cm/7'0" x 5'3"   | 206cm x 159cm/6'9" x 5'3" | 206cm x 167cm/6'9" x 5'6" |
| or One Single                                       | 190cm x 72cm/6'3" x 2'4"   | 180cm x 72cm/5'11" x 2'4"  | 167cm x 72cm/5'6" x 2'4"  | 167cm x 70cm/5'6" x 2'4"  | 190cm x 70cm/6'3" x 2'4"  |
| and One Single                                      | 190cm x 72cm/6'3" x 2'4"   | 190cm x 72cm/6'3" x 2'4"   | 159cm x 72cm/5'3" x 2'4"  | 159cm x 70cm/5'3" x 2'4"  | 167cm x 70cm/5'6" x 2'4"  |
| Rear Double   |                            |                            | 192cm x 138cm/6'4" x 4'6" | 190cm x 134cm/6'3" x 4'3" | 184cm x 133cm/6'0" x 4'4" |
| Side Single (offside)                               |                            | 180cm x 70cm/5'11" x 2'4"  |                           |                           |                           |
| Side Single (nearside)                              |                            |                            |                           |                           |                           |
| Side Bunk   |                            | 176cm x 59cm/5'9" x 1'11"  |                           |                           |                           |

**Bed sizes:** Please note that double bed sizes are quoted with wrap round seating.

**†Note on awning sizes:** Due to the varying awning designs and sizes the awning sizes given are approximate only. Specific awning sizes must be confirmed by your dealer or the awning manufacturer prior to purchase.

# Wiring Diagrams

## ELITE RANGE - ROAD LIGHTING

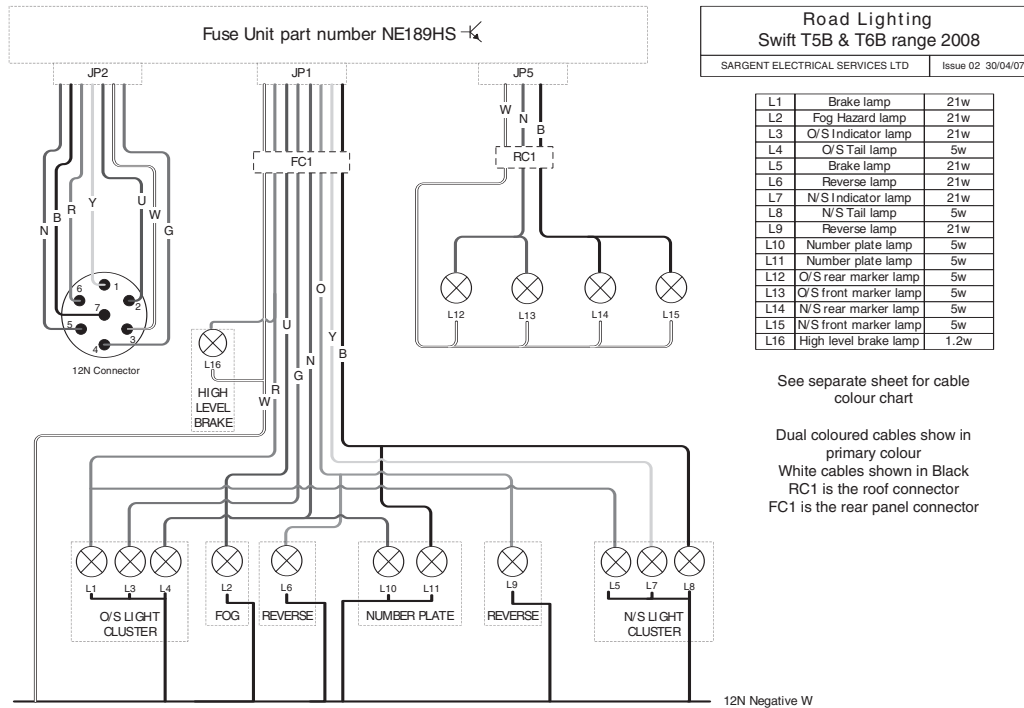

## ELITE RANGE - CONSUMER CIRCUITS - ROOF

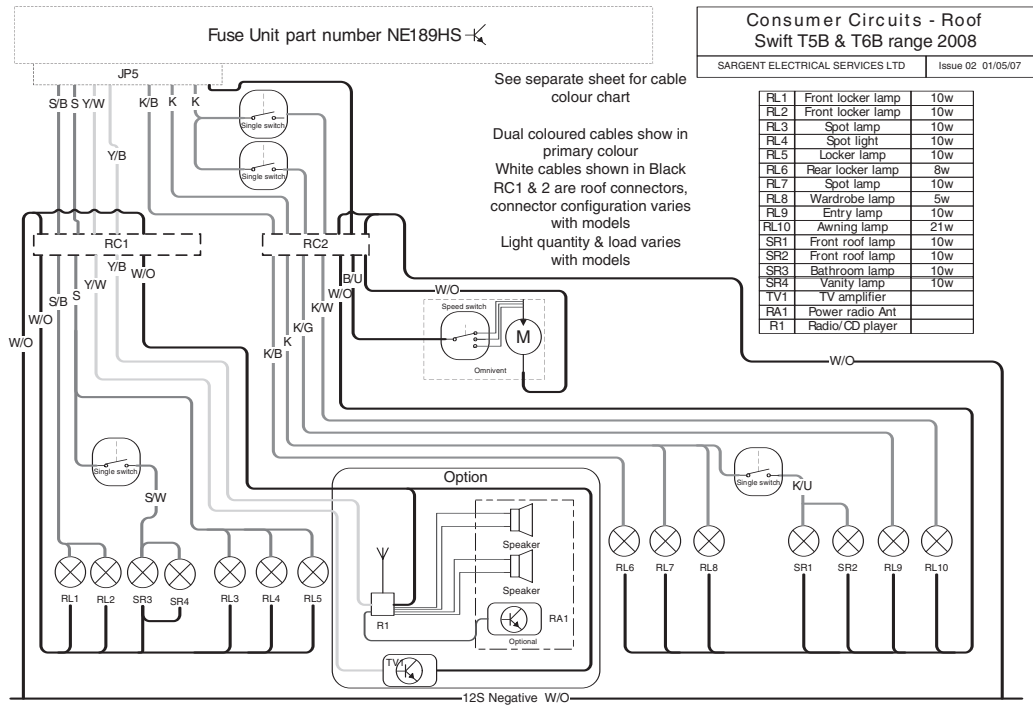

# Wiring Diagrams

## ELITE RANGE - CONSUMER CIRCUITS – FLOOR

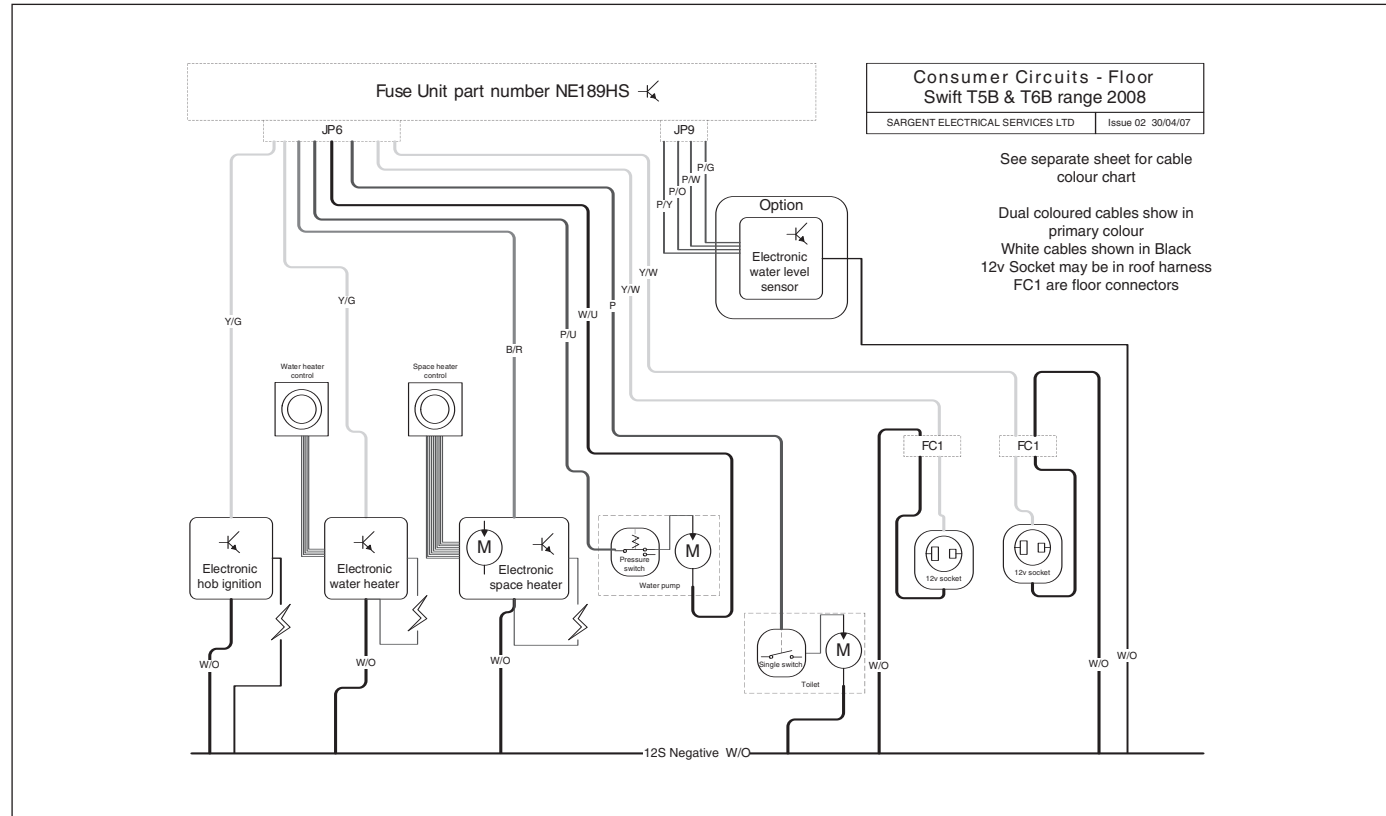

## ELITE RANGE - POWER CIRCUITS

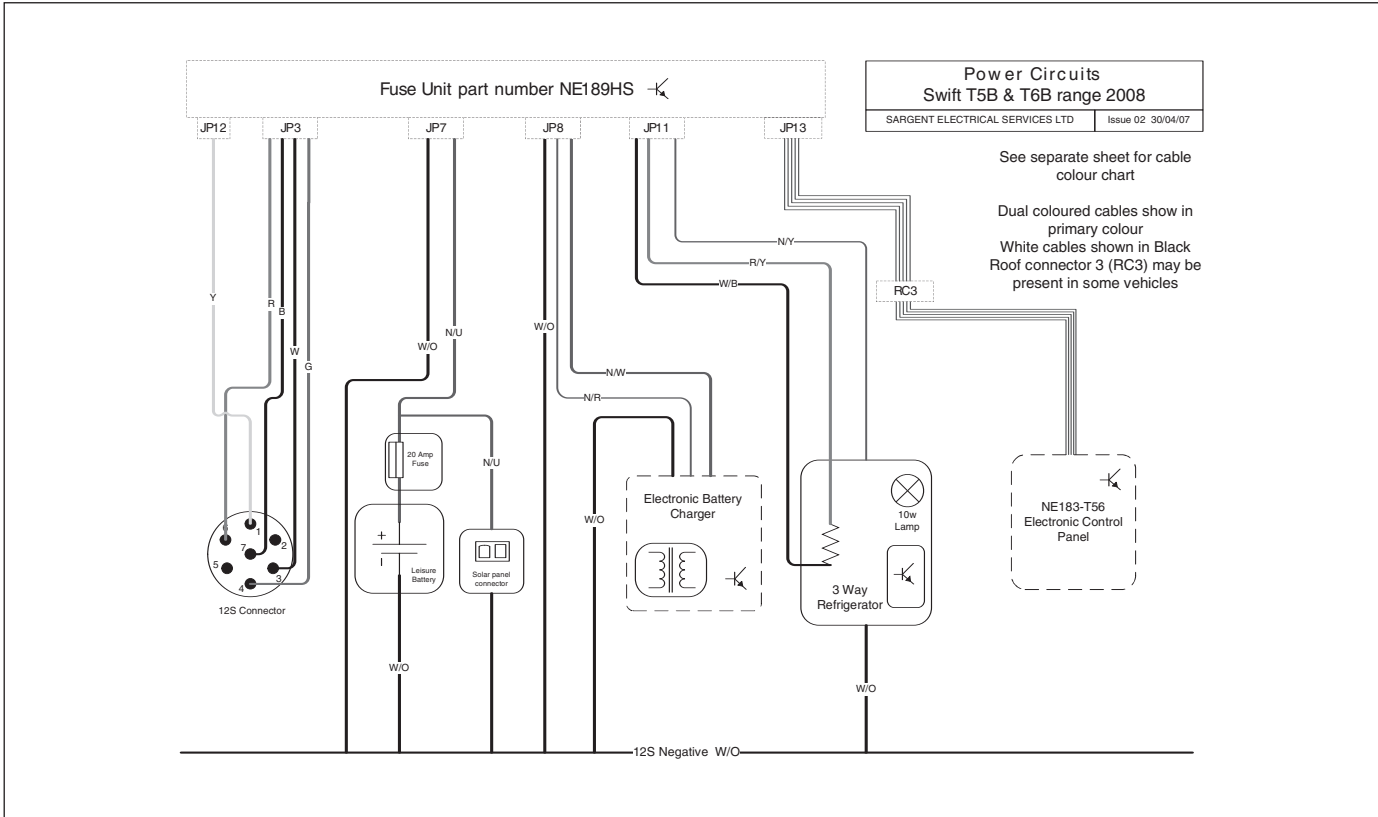

# Wiring Diagrams

## ELITE RANGE - 230V CIRCUITS

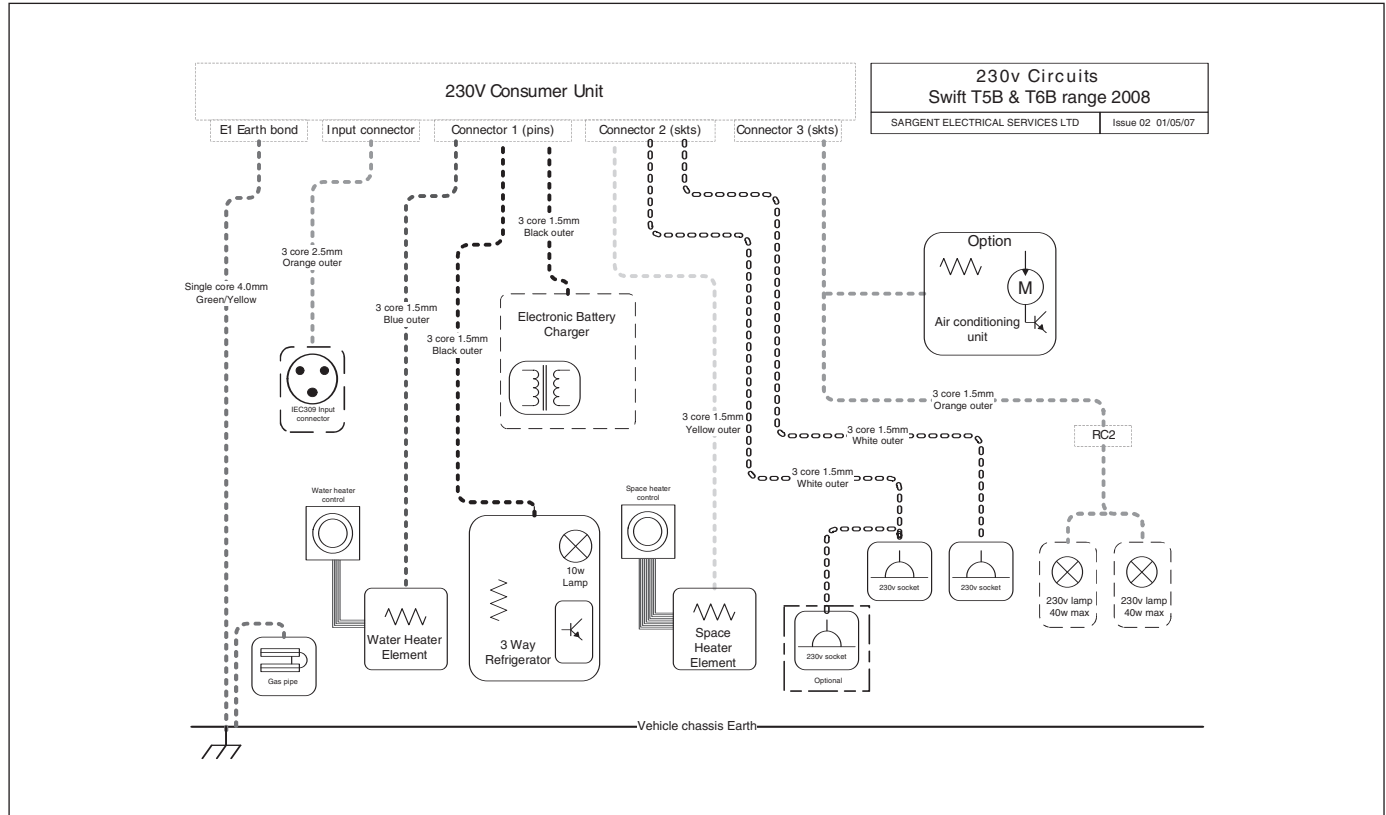

## ELITE RANGE - CONSUMER CIRCUITS – FLOOR WITH ALDE HEATING

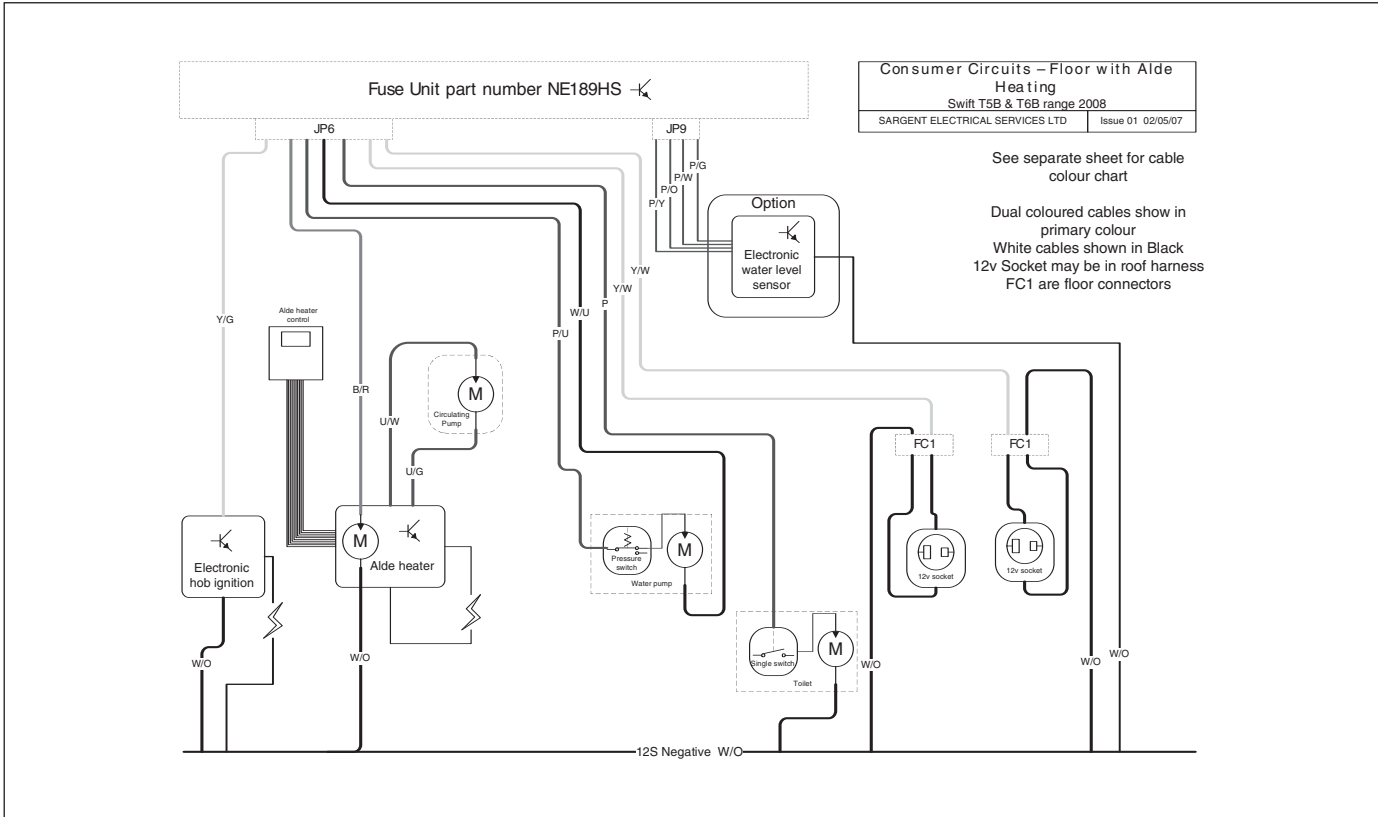

# Wiring Diagrams

## ELITE RANGE - 230V CIRCUITS WITH ALDE HEATING

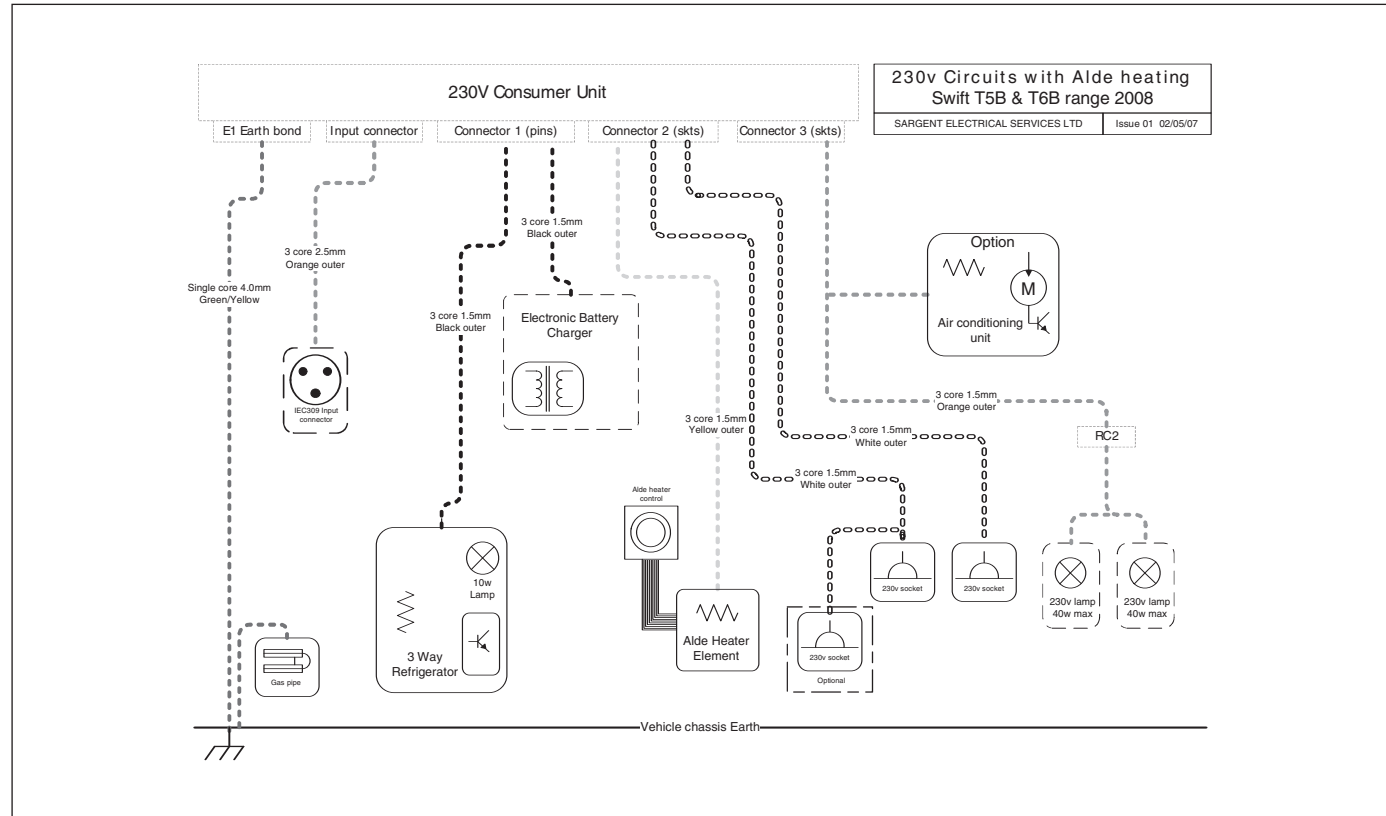

## ELITE RANGE - CABLE COLOUR CHART

|  |                 |
|--|-----------------|
| Cable Colour Chart<br>Swift range 2007 |                 |
| SARGENT ELECTRICAL SERVICES LTD        | Issue 01 1/1/07 |

### 12v Cable Colours

|   |            |
|---|------------|
| B | BLACK      |
| N | BROWN      |
| R | RED        |
| O | ORANGE     |
| Y | YELLOW     |
| G | GREEN      |
| U | BLUE       |
| P | PURPLE     |
| S | SLATE GREY |
| W | WHITE      |
| K | PINK       |

### 230v Cable Colours

|   |        |
|---|--------|
| B | BLACK  |
| N | BROWN  |
| W | WHITE  |
| O | ORANGE |
| Y | YELLOW |
| G | GREEN  |
| U | BLUE   |

# Bulb Replacement

|                                  | TYPE                | RATING        | ELITE |  |  |
|----------------------------------|---------------------|---------------|-------|--|--|
| <b>ROAD LIGHTS</b>               |                     |               |       |  |  |
| Front marker lights              | W5W                 | 12v 5w        | ✓     |  |  |
| Side marker                      | C5W                 | 12v 5w        | ✓     |  |  |
| Reversing light                  | P21                 | 12v 21w       | ✓     |  |  |
| Rear indicator light             | P21                 | 12v 21w       | ✓     |  |  |
| Brake / tail light               | P21/5W              | 12v 21w / 5w  | ✓     |  |  |
| Fog light                        | P21                 | 12v 21w       | ✓     |  |  |
| Number plate light               | C5W                 | 12v 5w        | ✓     |  |  |
| High level brake light           | 2DA 343 800-007     | LED           | ✓     |  |  |
| <b>INTERIOR/OTHER</b>            |                     |               |       |  |  |
| Awning light                     | P21W                | 12v 20w       | ✓     |  |  |
| Spot / reading lights            | GU5.3/MR16 Dichroic | GU5.3 12v 10w | ✓     |  |  |
| Downlighters                     | Halogen capsule     | G4 12v 10w    | ✓     |  |  |
| Round ceiling lights small white | Halogen capsule     | G4 12v 10w    | ✓     |  |  |
| Kitchen light                    | Fluorescent 300mm   | 12v 8w        | ✓     |  |  |
| Mains lights                     | Small screw         | 230v 40w      | ✓     |  |  |
|                                  |                     |               |       |  |  |

Note: Not all bulbs and lights feature on all models within a range