



Quality with Style

Swift Caravans

Dunswell Road, Cottingham, East Yorkshire HU16 4JX.

Tel: 01482 875740 Fax: 01482 840082

email: enquiry@swiftleisure.co.uk

website: www.swiftcaravans.co.uk

A MEMBER OF THE SWIFT GROUP

1079640 issued November 2007



Swift

Specification, wiring diagrams & bulb chart

Challenger





CONTENTS

Specification	1
Wiring Diagrams	
Road Lights	2
Consumer Circuits - Roof	3
Consumer Circuits - Floor	4
Power Circuits	5
230V Circuits	6
Cable Colour Chart	7
Bulb Replacement	8

Specifications

	CHALLENGER 480	CHALLENGER 490	CHALLENGER 530	CHALLENGER 540	CHALLENGER 560
Berths	2	5	4	4	4
Axles	1	1	1	1	1
Internal Length (bed box height)	4.74m/15'7"	5.50m/18'1"	5.50m/18'1"	5.50m/18'1"	5.60m/18'4"
Overall Width	2.29m/7'6"	2.29m/7'6"	2.29m/7'6"	2.29m/7'6"	2.29m/7'6"
Overall Height (inc. TV Aerial)	2.70m/8'10"	2.70m/8'10"	2.70m/8'10"	2.70m/8'10"	2.70m/8'10"
Maximum Internal Headroom	1.95m/6'5"	1.95m/6'5"	1.95m/6'5"	1.95m/6'5"	1.95m/6'5"
Overall Length	6.42m/21'1"	7.18m/23'7"	7.18m/23'7"	7.18m/23'7"	7.28m/23'10"
Mass in Running Order (inc. tolerance)	1184kg/23.3cwt	1340kg/26.4cwt	1345kg/26.5cwt	1290kg/25.4cwt	1289kg/25.4cwt
Essential Habitation Equipment Payload	69kg/1.4cwt	69kg/1.4cwt	69kg/1.4cwt	69kg/1.4cwt	69kg/1.4cwt
Personal Effects Payload	105kg/2.1cwt	143kg/2.8cwt	133kg/2.6cwt	133kg/2.6cwt	134kg/2.6cwt
Optional Equipment Payload	8kg/0.2cwt	8kg/0.2cwt	8kg/0.2cwt	8kg/0.2cwt	8kg/0.2cwt
Total user Payload	182kg/3.7cwt	220kg/4.4cwt	210kg/4.2cwt	210kg/4.2cwt	211kg/4.2cwt
Maximum Technical Permissible Laden Mass (DECLARED)	1366kg/27.0cwt	1560kg/30.8cwt	1555kg/30.7cwt	1500kg/29.5cwt	1500kg/29.5cwt
Maximum Technical Permissible Laden Mass (POSSIBLE)	1500kg/29.5cwt	1600kg/31.5cwt	1600kg/31.5cwt	1500kg/29.5cwt	1500kg/29.5cwt
Awning A/A dimension [†]	9.11m/29'11"	9.87m/32'5"	9.87m/32'5"	9.87m/32'5"	9.97m/32'8"
Tyre Size	175 r14 99	205/65 r15 102	205/65 r15 102	175 r14 99	175 r14 99
Tyre pressure at DECLARED MTPLM	58psi	50psi	50psi	65psi	65psi
Tyre pressure at POSSIBLE MTPLM	65psi	52psi	52psi	65psi	65psi
Static Load on Coupling Head	100kg	100kg	100kg	100kg	100kg
Thermal Insulation Grade	TWO	TWO	TWO	TWO	TWO
Bed Sizes					
Front Double	213cm x 180cm/7'0" x 5'11"	213cm x 180cm/7'0" x 5'11"	213cm x 180cm/7'0" x 5'11"	213cm x 159cm/7'0" x 5'3"	213cm x 143cm/7'0" x 4'8"
or One Single	190cm x 72cm/6'3" x 2'4"	180cm x 72cm/5'11" x 2'4"	180cm x 72cm/5'11" x 2'4"	167cm x 72cm/5'6" x 2'4"	
and One Single	190cm x 72cm/6'3" x 2'4"	190cm x 72cm/6'3" x 2'4"	190cm x 72cm/6'3" x 2'4"	159cm x 72cm/5'3" x 2'4"	
Rear Double		213cm x 138cm/7'0" x 4'6"		192cm x 138cm/6'4" x 4'6"	187cm x 133cm/6'2" x 4'4"
Rear Bunk		194cm x 56cm/6'4" x 1'10"			
Side Single (Offside)			180cm x 70cm/5'11" x 2'4"		
Side Single (Nearside)					
Side Bunk			176cm x 59cm/5'9" x 1'11"		

Bed sizes: Please note that double bed sizes are quoted with wrap round seating.

†Note on awning sizes: Due to the varying awning designs and sizes the awning sizes given are approximate only. Specific awning sizes must be confirmed by your dealer or the awning manufacturer prior to purchase.

* Estimated weight

Wiring Diagrams

CHALLENGER RANGE - ROAD LIGHTING

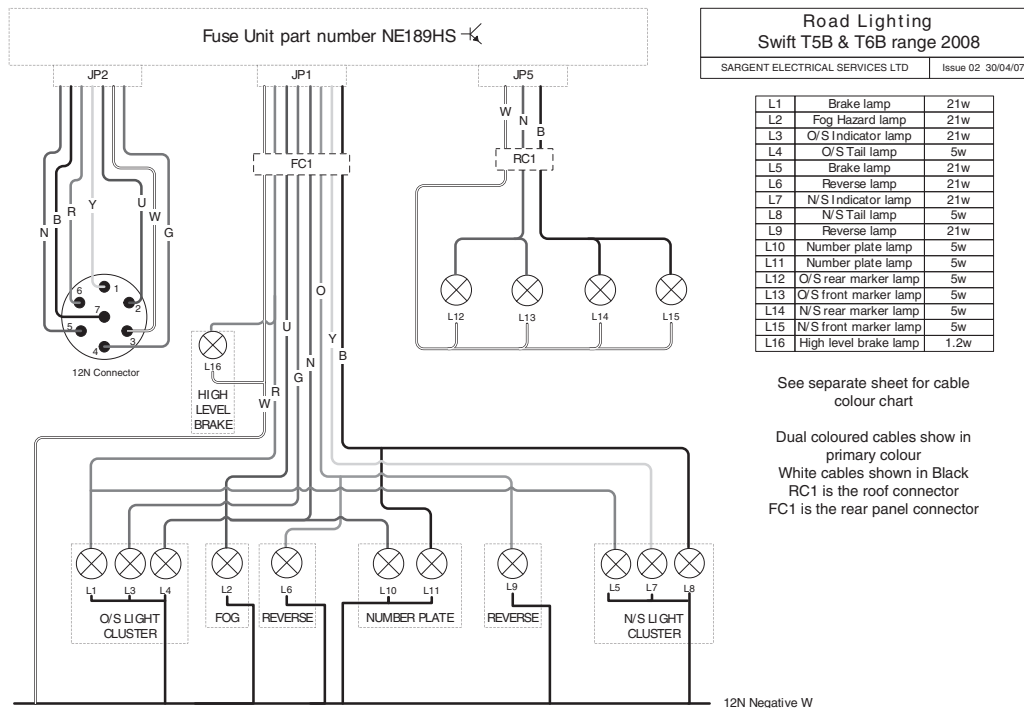

CHALLENGER RANGE - CONSUMER CIRCUITS – ROOF

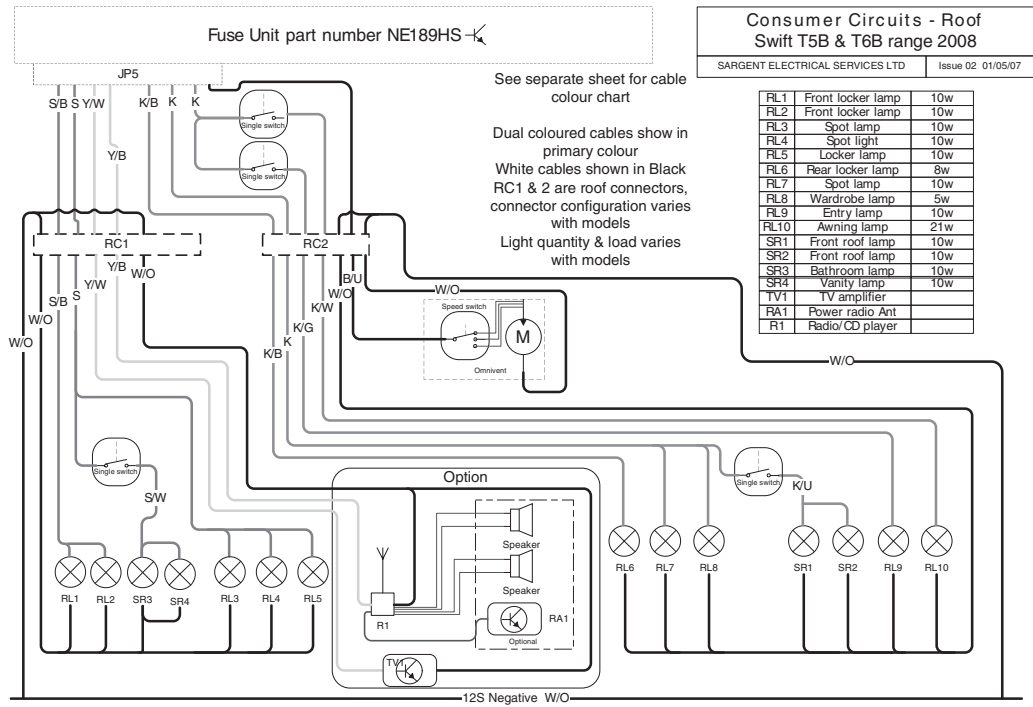

Wiring Diagrams

CHALLENGER RANGE - CONSUMER CIRCUITS – FLOOR

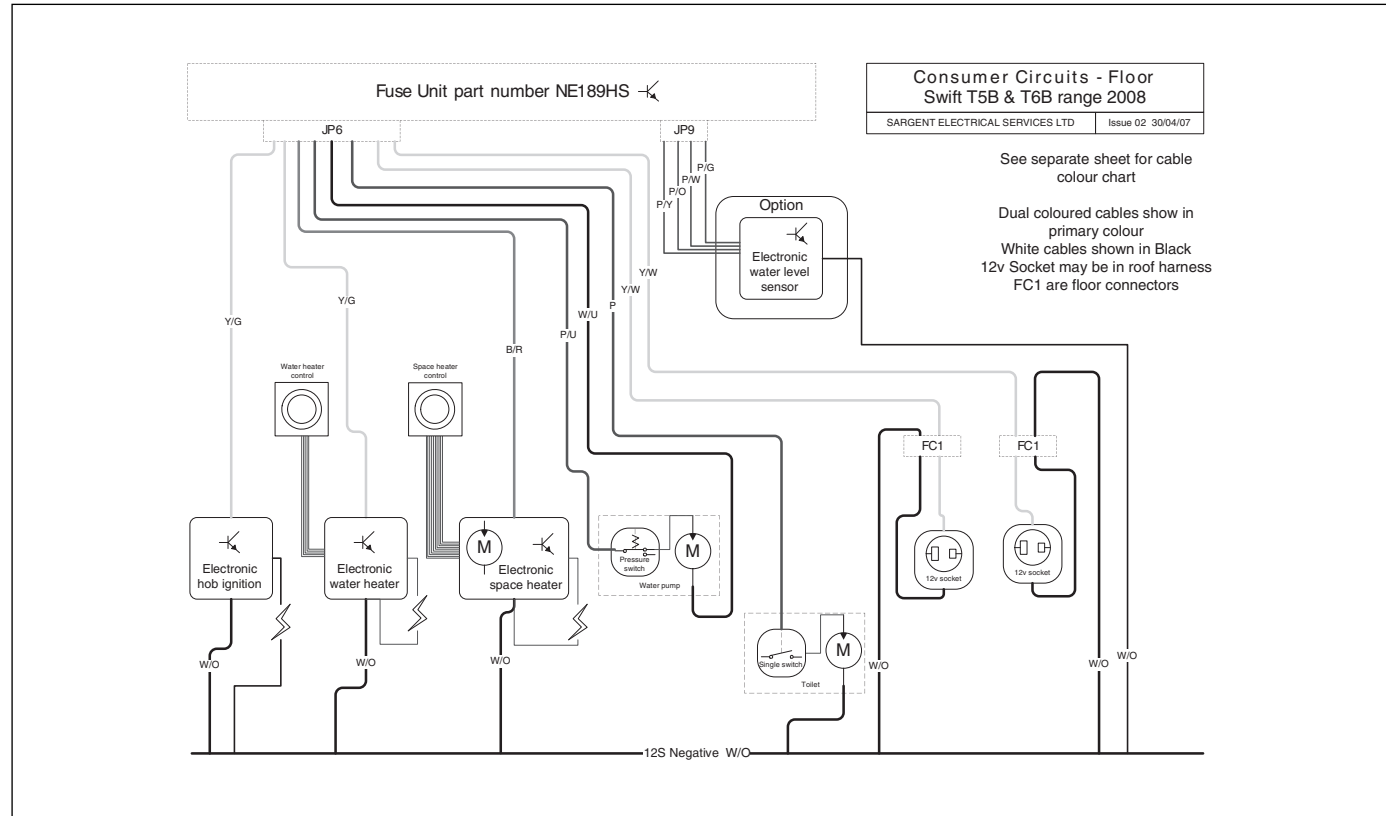

Consumer Circuits - Floor Swift T5B & T6B range 2008	
SARGENT ELECTRICAL SERVICES LTD	Issue 02 30/04/07

See separate sheet for cable colour chart

Dual coloured cables show in primary colour
White cables shown in Black
12v Socket may be in roof harness
FC1 are floor connectors

CHALLENGER RANGE - POWER CIRCUITS

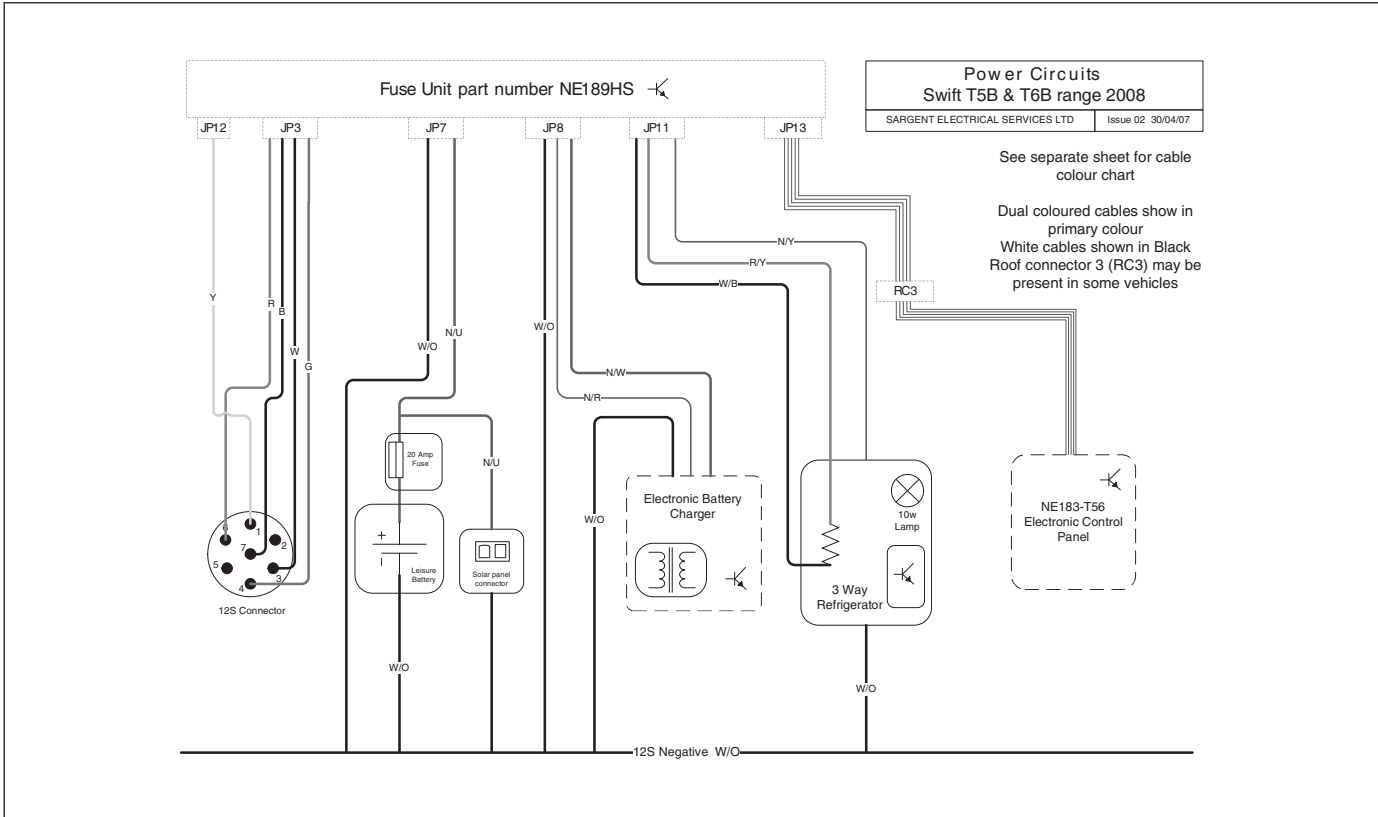

Wiring Diagrams

CHALLENGER RANGE - 230V CIRCUITS

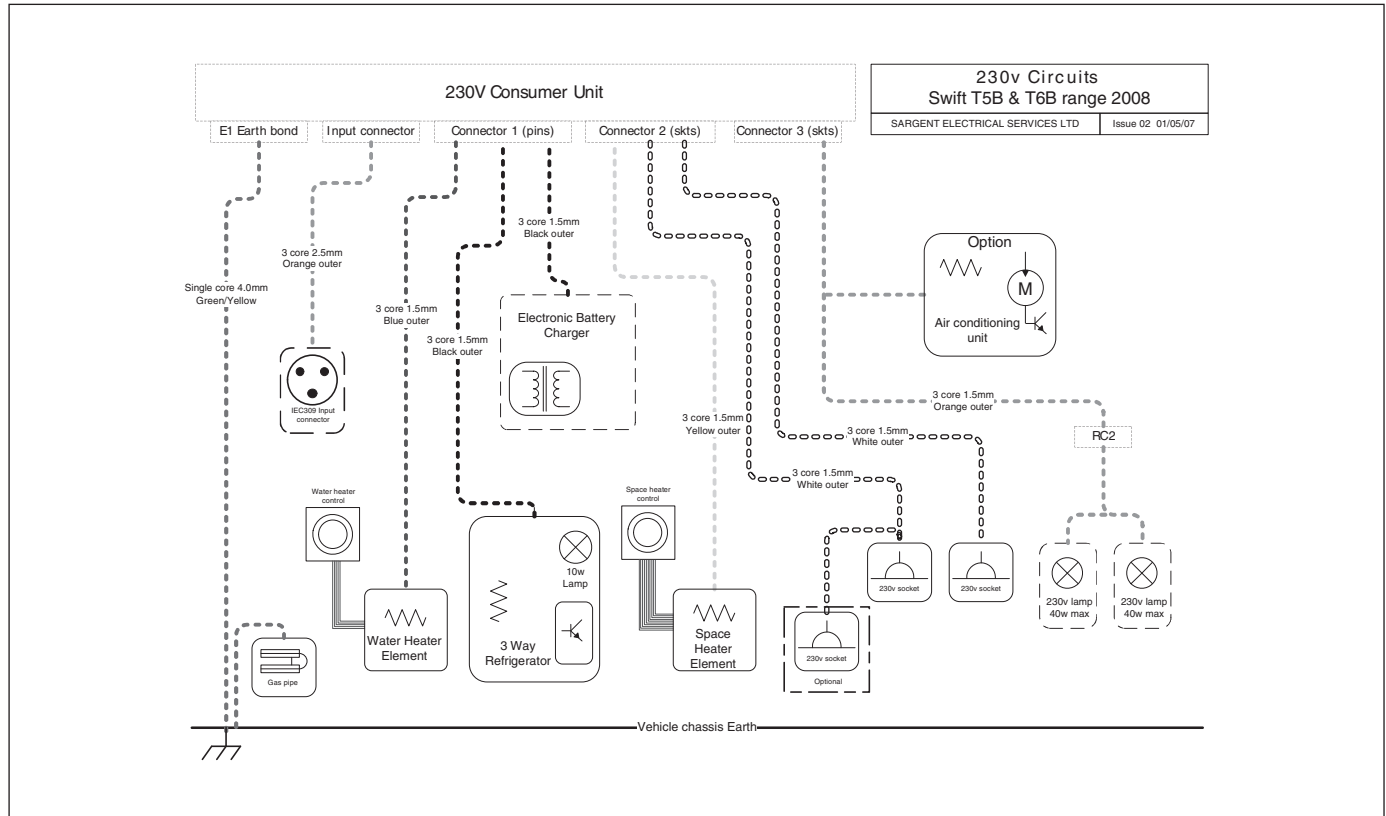

CHALLENGER RANGE - CABLE COLOUR CHART

Cable Colour Chart Swift range 2007	
SARGENT ELECTRICAL SERVICES LTD	Issue 01 1/1/07

12v Cable Colours

B	BLACK
N	BROWN
R	RED
O	ORANGE
Y	YELLOW
G	GREEN
U	BLUE
P	PURPLE
S	SLATE GREY
W	WHITE
K	PINK

230v Cable Colours

B	BLACK
N	BROWN
W	WHITE
O	ORANGE
Y	YELLOW
G	GREEN
U	BLUE

Bulb Replacement

	TYPE	RATING	CHALLENGER		
ROAD LIGHTS					
Front marker lights	W5W	12v 5w	✓		
Side marker	C5W	12v 5w	✓		
Reversing light	P21	12v 21w	✓		
Rear indicator light	P21	12v 21w	✓		
Brake / tail light	P21/5W	12v 21w / 5w	✓		
Fog light	P21	12v 21w	✓		
Number plate light	C5W	12v 5w	✓		
High level brake light	2DA 343 800-007	LED	✓		
INTERIOR/OTHER					
Awning light	P21W	12v 20w	✓		
Spot / reading lights	GU5.3/MR16 Dichroic	GU5.3 12v 10w	✓		
Downlighters	Halogen capsule	G4 12v 10w	✓		
Round ceiling lights small white	Halogen capsule	G4 12v 10w	✓		
Kitchen light	Fluorescent 300mm	12v 8w	✓		
Mains lights	Small screw	230v 40w	✓		

Note: Not all bulbs and lights feature on all models within a range