

Ace Caravan

Owner's Service Handbook



Enjoy the freedom



Caravan Details

IMPORTANT Enter all your caravan details on this page (see specification in rear of this handbook).

Model
Model Year
Chassis Number
Key Number
Hitch/Steady Lock Key Number
Internal Length
Overall Length
Overall Width
Maximum External Height
Mass in Running Order
User Payload
Maximum Technical Permissible Laden Mass
Nose Weight
Awning Size
Tyre Pressures/Size

Supplied and Pre-delivery Inspection by:

Service History

Signed/Dealer

Date



CONTENTS

Annual Service/Inspection Record	2
Warranty.....	5
Specifications.....	6
Wiring Diagrams – Road Lights	8
Wiring Diagrams – Internal Wiring	10
Bulb Replacement	12
Change of Ownership	

TOURING CARAVANS - ANNUAL SERVICE/INSPECTION RECORD

In order to comply with the warranty, you must have your caravan inspected and serviced by an authorised Swift Group Service Centre at least once per year.

It is important that the Owner's Handbook is stamped on the appropriate page by the authorised Swift Group Service Centre. Failure to do this will invalidate the warranty and the transfer of the warranty on the change of ownership.

The inspection should take approximately two to four hours and will cover the areas dealt with in the annual service check list. Any areas requiring service and/or maintenance will be highlighted by your dealer and we recommend that you authorise any necessary work to be carried out.

NB. It is essential, to validate the warranty, that an annual inspection be carried out by an authorised Swift Group Service Centre covering the items listed.

1. Damp and lamination test.
2. Coupling head and breakaway cable.
3. Jockey wheel.
4. Chassis and chassis to body security.
5. Corner steadies.
6. Folding step (if fitted).
7. Tyres and tyre pressures.
8. Torque wheel nuts.
9. Brake rods and linkages.
10. Hub bearings, brakes and brake shoes.
11. Handbrake operation and performance.
12. Suspension and shock absorbers (if fitted).
13. 12N and 12S 7-pin plugs and cables.
14. Road lights, wiring and reflectors.
15. Internal lights and 12V DC system.
16. Water heater - gas and 230V AC (if fitted).
17. Hob, grill and oven (if fitted).
18. Refrigerator 230V AC, 12V DC and gas.
19. Gas system.
20. Water pump, taps and water system.
21. Mains 230V AC system.
22. Windows and fittings.
23. Smoke alarm and battery.
24. Roof lights.
25. Furniture hinges/stays etc.
26. Exterior locks and hinges.
27. Grab handle security.
28. All internal vents.
29. Oil seals.
30. Blinds and fly screens (if fitted).

ANNUAL SERVICE/INSPECTION RECORD

CARAVAN MODEL _____ YEAR _____

CHASSIS NUMBER _____

<p>1st SERVICE</p> <p>DATE:</p> <p>DEALER'S STAMP</p> <p>We certify that an annual service has been carried out in accordance with the handbook.</p>	<p>2nd SERVICE</p> <p>DATE:</p> <p>DEALER'S STAMP</p> <p>We certify that an annual service has been carried out in accordance with the handbook.</p>
<p>3rd SERVICE</p> <p>DATE:</p> <p>DEALER'S STAMP</p> <p>We certify that an annual service has been carried out in accordance with the handbook.</p>	<p>4th SERVICE</p> <p>DATE:</p> <p>DEALER'S STAMP</p> <p>We certify that an annual service has been carried out in accordance with the handbook.</p>

5th SERVICE

DATE:

DEALER'S STAMP

We certify that an annual service has been carried out in accordance with the handbook.

6th SERVICE

DATE:

DEALER'S STAMP

We certify that an annual service has been carried out in accordance with the handbook.

7th SERVICE

DATE:

DEALER'S STAMP

We certify that an annual service has been carried out in accordance with the handbook.

8th SERVICE

DATE:

DEALER'S STAMP

We certify that an annual service has been carried out in accordance with the handbook.

9th SERVICE

DATE:

DEALER'S STAMP

We certify that an annual service has been carried out in accordance with the handbook.

10th SERVICE

DATE:

DEALER'S STAMP

We certify that an annual service has been carried out in accordance with the handbook.

All the illustrations and descriptive matter in this handbook are intended to give a general idea of the caravan. Changing market and supply situations and our policy of continuous product development may prevent us from maintaining the exact specifications detailed in this handbook. We therefore reserve the right to alter specifications as materials and conditions demand.

Dealers are not agents of Swift Group Limited, the manufacturer of Swift Group caravans, and have absolutely no authority to bind the manufacturer by any express or implied undertaking or representation.

All caravans have a 3 year SuperSure warranty from the date of purchase (or hire purchase), which is subject to a chargeable annual service and inspection being carried out at an authorised Swift Group Service Centre.

In the first 12 months this covers faults arising from a manufacturing defect but not those which are a result of normal wear and tear. The manufacturer will honour the warranty until 36 months from the date of sale, and providing that the caravan has been serviced annually within 90 days before or 30 days after the anniversary of the original sale. The third service must, however, be carried out before the expiry of the 36 month period from the original date of sale.

In years two and three the warranty will cover:

- i) All original components of the caravan including permanently fitted equipment forming part of the manufacturer's original specification.
- ii) Water ingress and body delamination.

Specific exclusions to SuperSure warranty:

Tyres, glass, paint, brightwork and all similar trim and finish. Soft furnishings, carpets, floor coverings, work surfaces and all other décor. Window catches, stays and associated fittings. Adjustments of brakes, blinds, hinges, catches, stays and doors. Replacement of bulbs, fluorescent tubes, fuses and electrical connections. Natural movement of internal doors and furniture. Audio equipment. Fair wear and tear.

The warranty will be invalidated if the caravan has been neglected, misused or modified. The warranty on all internal components will be invalidated if the caravan has been used for hire or reward. The caravan will be deemed to have been neglected if it has not been serviced and maintained as stated in this handbook.

The warranty only applies to caravans purchased and used within the UK, and for continuous journeys abroad of no longer than 90 days per journey.

The cost of transporting, towing or moving the caravan by any means to or from the place of repair is the responsibility of the owner.

The benefit of this warranty may be transferred to a new owner if the caravan is sold, provided that the caravan has been serviced by an authorised service centre in accordance with the requirements of this handbook, and details of the change of ownership have been supplied to Swift using the change of ownership form set out in this handbook. Failure to notify Swift of a change of ownership within 14 days of such change will invalidate the warranty.

This warranty only applies to caravans purchased in the UK.

The above conditions in no way affect your statutory rights in respect of the caravan.

Specifications

JUBILEE	Diplomat	Ambassador	Viceroy	Globetrotter	Herald	Statesman
Berths	2	2	5	4	4	4
Internal Length (bed box height)	3.94m/12'11"	4.61m/15'2"	5.23m/17'2"	5.23m/17'2"	5.23m/17'2"	5.39m/17'8"
Overall Width	2.23m/7'4"	2.23m/7'4"	2.23m/7'4"	2.23m/7'4"	2.23m/7'4"	2.23m/7'4"
Overall Height (inc. TV Aerial)	2.76m/9'1"	2.76m/9'1"	2.76m/9'1"	2.76m/9'1"	2.76m/9'1"	2.76m/9'1"
Overall Length	5.52m/18'1"	6.19m/20'4"	6.81m/22'4"	6.81m/22'4"	6.81m/22'4"	6.97m/22'10"
Mass in Running Order (inc. tolerance)	929kg/18.3cwt	1011kg/19.9cwt	1157kg/22.8cwt	1134kg/22.3cwt	1122kg/22.1cwt	1154kg/22.7cwt
Essential Habitation Equipment Payload	90kg/1.8cwt	82kg/1.6cwt	90kg/1.8cwt	82kg/1.6cwt	82kg/1.6cwt	82kg/1.6cwt
Personal Effects Payload	96kg/1.9cwt	103kg/2.0cwt	139kg/2.7cwt	129kg/2.5cwt	129kg/2.5cwt	131kg/2.6cwt
Optional Equipment Payload	27kg/0.5cwt	27kg/0.5cwt	27kg/0.5cwt	27kg/0.5cwt	27kg/0.5cwt	27kg/0.5cwt
Maximum Technical Permissible Laden Mass (DECLARED)	1142kg/22.5cwt	1223kg/24.1cwt	1413kg/27.8cwt	1372kg/27.0cwt	1360kg/26.8cwt	1394kg/27.4cwt
Maximum Technical Permissible Laden Mass (POSSIBLE)	1350kg/26.6cwt	1350kg/26.6cwt	1500kg/29.5cwt	1500kg/29.5cwt	1500kg/29.5cwt	1500kg/29.5cwt
Awning A/A dimension	8.17m/26'10"	8.85m/29'0"	9.47m/31'1"	9.47m/31'1"	9.47m/31'1"	9.63m/31'7"
Tyre Size	195/70 r14 95	195/70 r14 95	175 r14 99	175 r14 99	175 r14 99	175 r14 99
Tyre pressure at DECLARED MTPLM	33 psi	38 psi	59 psi	59 psi	59 psi	59 psi
Tyre pressure at POSSIBLE MTPLM	42 psi	42 psi	65 psi	65 psi	65 psi	65 psi
Static Load on Coupling Head	100kg	100kg	100kg	100kg	100kg	100kg
Thermal Insulation & Heating Grade	TWO	TWO	TWO	TWO	TWO	TWO
Bed Sizes						
Front Double	208cm x 190cm 6'10" x 6'3"	208cm x 190cm 6'10" x 6'3"	208cm x 190cm 6'10" x 6'3"	208cm x 180cm 6'10" x 5'11"	208cm x 139cm 6'10" x 4'7"	208cm x 167cm 6'10" x 5'6"
or One Single	190cm x 71cm 6'3" x 2'4"	190cm x 71cm 6'3" x 2'4"	190cm x 71cm 6'3" x 2'4"	190cm x 71cm 6'3" x 2'4"	190cm x 71cm 6'3" x 2'4"	190cm x 71cm 6'3" x 2'4"
and One Single	190cm x 71cm 6'3" x 2'4"	190cm x 71cm 6'3" x 2'4"	190cm x 71cm 6'3" x 2'4"	180cm x 71cm 5'11" x 2'4"	190cm x 71cm 6'3" x 2'4"	167cm x 71cm 5'6" x 2'4"
Rear Double			208cm x 132cm 6'10" x 4'4"			198cm x 138cm 6'6" x 4'6"
Rear Bunk			192cm x 56cm 6'4" x 1'10"			
Side Single				180cm x 66cm 5'11" x 2'2"	180cm x 66cm 5'11" x 2'2"	
Side Bunk				178cm x 56cm 5'10" x 1'10"	178cm x 56cm 5'10" x 1'10"	

Do not put the spare wheel in the gas bottle box in the Jubilee Statesman.
A spare wheel carrier is provided in these models and must be used to achieve correct nose weight

Please note that double bed sizes are quoted with wrap round seating

Specifications

AWARD	Daystar	Brightstar	Nightstar	Morningstar	Transtar	Northstar
Berths	2	2	5	4	4	4
Internal Length (bed box height)	3.94m/12'11"	4.61m/15'2"	5.23m/17'2"	5.23m/17'2"	5.23m/17'2"	5.39m/17'8"
Overall Width	2.23m/7'4"	2.23m/7'4"	2.23m/7'4"	2.23m/7'4"	2.23m/7'4"	2.23m/7'4"
Overall Height (inc. TV Aerial)	2.76m/9'1"	2.76m/9'1"	2.76m/9'1"	2.76m/9'1"	2.76m/9'1"	2.76m/9'1"
Overall Length	5.56m/18'3"	6.28m/20'7"	6.93m/22'9"	6.93m/22'9"	6.93m/22'9"	7.06m/23'2"
Mass in Running Order (inc. tolerance)	966kg/19.0cwt	1069kg/21.0cwt	1199kg/23.6cwt	1193kg/23.5cwt	1184kg/23.3cwt	1209kg/23.8cwt
Essential Habitation Equipment Payload	90kg/1.8cwt	82kg/1.6cwt	90kg/1.8cwt	82kg/1.6cwt	82kg/1.6cwt	82kg/1.6cwt
Personal Effects Payload	96kg/1.9cwt	104kg/2.0cwt	140kg/2.8cwt	130kg/2.6cwt	130kg/2.6cwt	131kg/2.6cwt
Optional Equipment Payload	27kg/0.5cwt	27kg/0.5cwt	27kg/0.5cwt	27kg/0.5cwt	27kg/0.5cwt	27kg/0.5cwt
Maximum Technical Permissible Laden Mass (DECLARED)	1179kg/23.2cwt	1282kg/25.2cwt	1456kg/28.7cwt	1432kg/28.2cwt	1423kg/28.0cwt	1449kg/28.5cwt
Maximum Technical Permissible Laden Mass (POSSIBLE)	1350kg/26.6cwt	1350kg/26.6cwt	1500kg/29.5cwt	1500kg/29.5cwt	1500kg/29.5cwt	1500kg/29.5cwt
Awning A/A dimension	8.17m/26'10"	8.89m/29'2"	9.54m/31'4"	9.54m/31'4"	9.54m/31'4"	9.67m/31'9"
Tyre Size	195/70r14 95	195/70r14 95	175r14 99	175r14 99	175r14 99	175r14 99
Tyre pressure at DECLARED MTPLM	36 psi	40 psi	61 psi	61 psi	61 psi	61 psi
Tyre pressure at POSSIBLE MTPLM	42 psi	42 psi	65 psi	65 psi	65 psi	65 psi
Static Load on Coupling Head	100kg	100kg	100kg	100kg	100kg	100kg
Thermal Insulation & Heating Grade	TWO	TWO	TWO	TWO	TWO	TWO
Bed Sizes						
Front Double	208cm x 190cm 6'10" x 6'3"	208cm x 190cm 6'10" x 6'3"	208cm x 190cm 6'10" x 6'3"	208cm x 180cm 6'10" x 5'11"	208cm x 139cm 6'10" x 4'7"	208cm x 167cm 6'10" x 5'6"
or One Single	190cm x 71cm 6'3" x 2'4"	190cm x 71cm 6'3" x 2'4"	190cm x 71cm 6'3" x 2'4"	190cm x 71cm 6'3" x 2'4"	190cm x 71cm 6'3" x 2'4"	190cm x 71cm 6'3" x 2'4"
and One Single	190cm x 71cm 6'3" x 2'4"	190cm x 71cm 6'3" x 2'4"	190cm x 71cm 6'3" x 2'4"	180cm x 71cm 5'11" x 2'4"	190cm x 71cm 6'3" x 2'4"	167cm x 71cm 5'6" x 2'4"
Rear Double			208cm x 132cm 6'10" x 4'4"			198cm x 138cm 6'6" x 4'6"
Rear Bunk			192cm x 56cm 6'4" x 1'10"			
Side Single				180cm x 66cm 5'11" x 2'2"	180cm x 66cm 5'11" x 2'2"	
Side Bunk				178cm x 56cm 5'10" x 1'10"	178cm x 56cm 5'10" x 1'10"	

Please note that double bed sizes are quoted with wrap round seating

Do not put the spare wheel in the gas bottle box in the Award NorthStar.
A spare wheel carrier is provided in these models and must be used to achieve correct nose weight

Wiring Diagrams

JUBILEE RANGE 2003 - ROAD LIGHTS

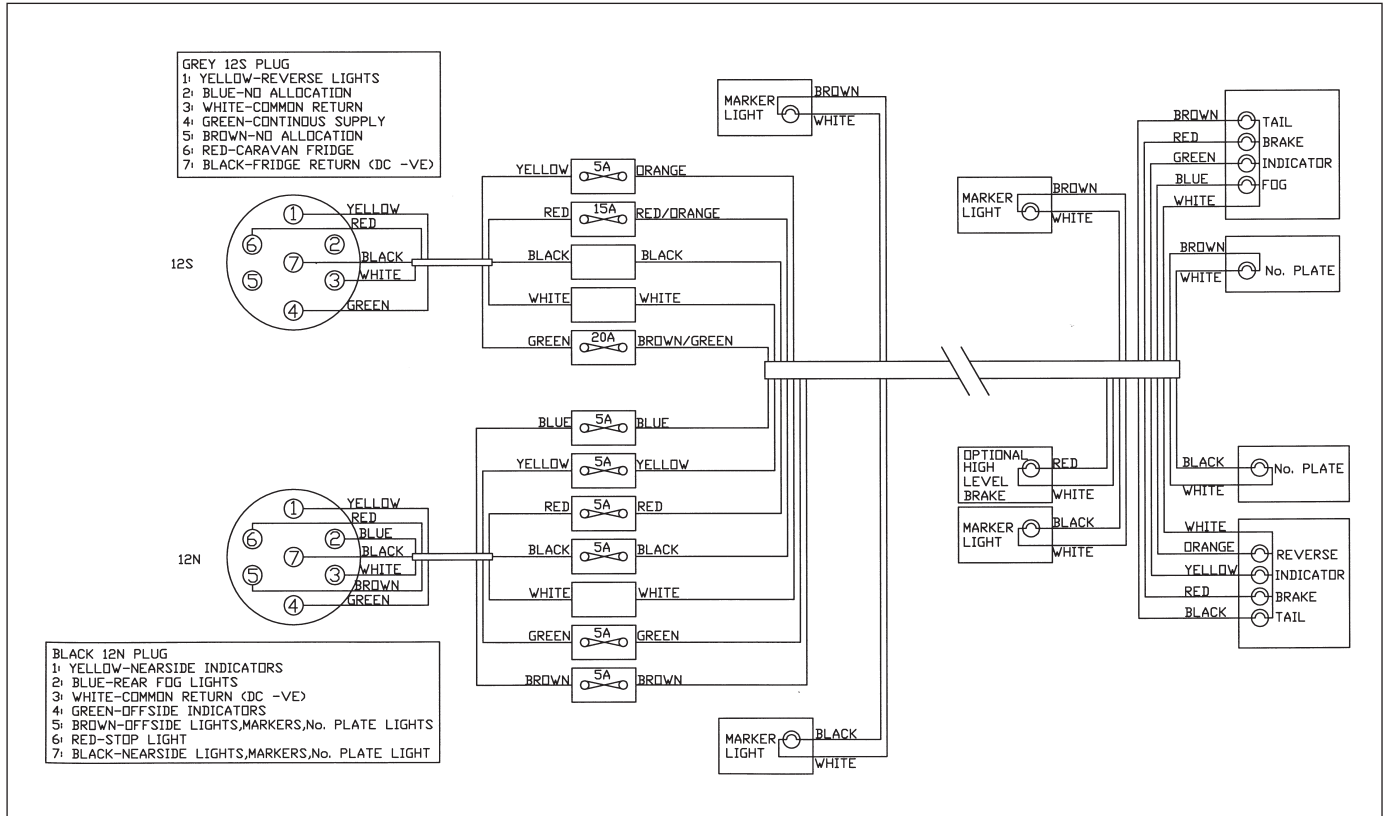

AWARD RANGE 2003 - ROAD LIGHTS

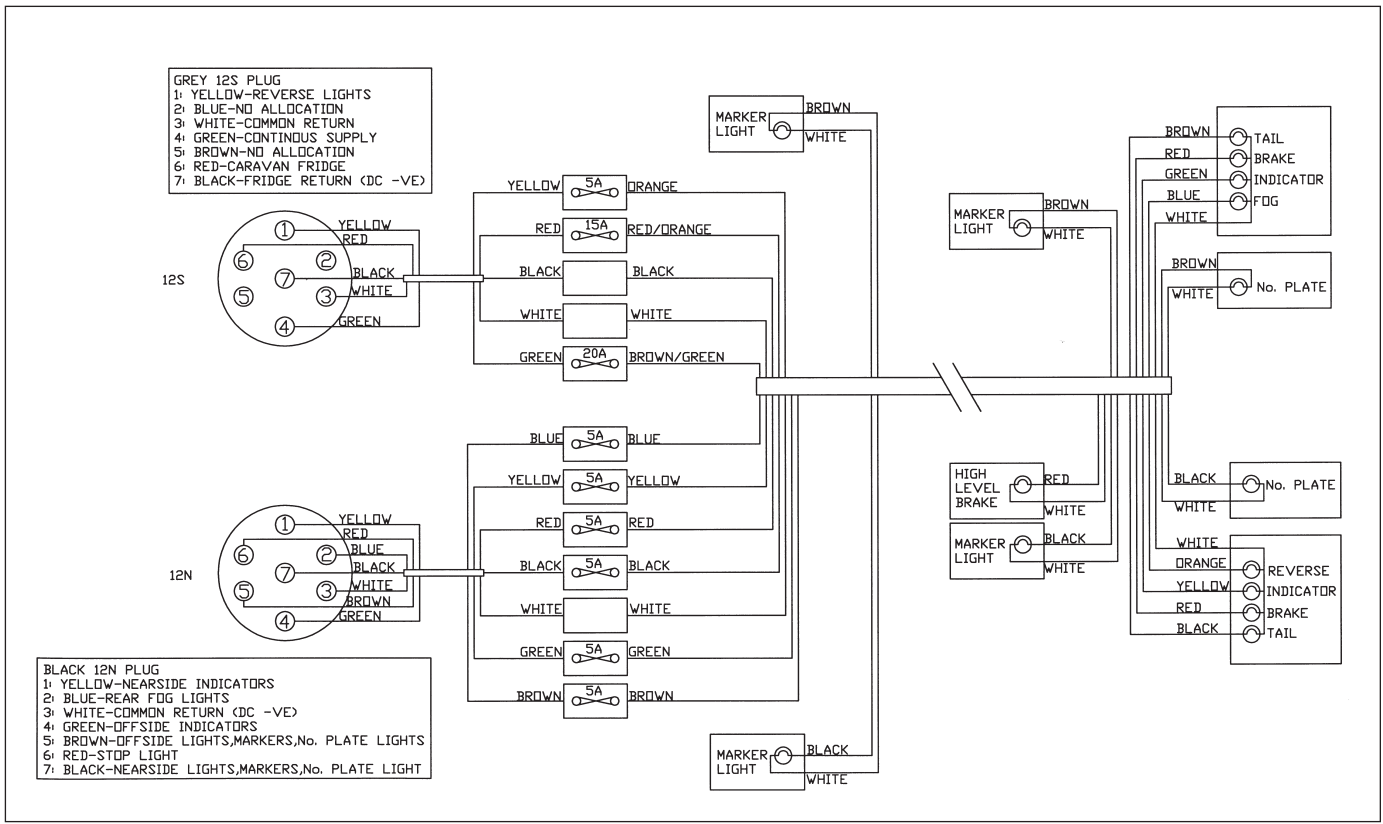

Bulb Replacement

	TYPE	POWER	JUBILEE	AWARD
ROAD LIGHTS				
Front marker lights	W5W	12v 5w	✓	✓
Side marker	F239	12v 5w	✓	✓
Reversing light	L382	12v 21w	✓	✓
Rear indicator light	L382	12v 21w	✓	
Rear indicator light	PY21W Orange bulb	12v 21w		✓
Brake / tail light	L380	12v 21w/5w	✓	✓
Fog light	L382	12v 21w	✓	✓
Number plate light	F239	12v 5w	✓	✓
High level brake light	Capless	12v 2.3w		✓
INTERIOR/OTHER				
Awning (Internal switch)	P21W	12v 20w		✓
Awning - (External switch)	L245	12v 10w	✓	
Spot / reading lights	Halogen capsule	G4 12v 10w	✓	✓
Round ceiling lights	Flourescent U-shape	12v 9w		✓
Round ceiling lights	Halogen capsule	G4 20w	✓	✓
Kitchen strip light	Flourescent tube 300mm	12v 8w	✓	✓
Tulip mains lights	Small screw	240v 40w	✓	
Downlighters	Screw spotlight bulb	240v 60w		✓

Note: Not all lights and bulbs feature on all models within a range

NOTIFICATION OF CHANGE OF OWNERSHIP

If you sell your caravan, please notify the change of ownership by completing this page, detaching it and sending it to:
Swift Group Ltd., Dunswell Road, Cottingham, East Yorkshire, HU16 4JX.

DETAILS OF CARAVAN:	Model:	_____
	Chassis No:	_____
CURRENT OWNER:	Name:	_____
	Address:	_____

NEW OWNER:	Name:	_____
	Address:	_____

Please note that the benefit of any unexpired warranty cannot be transferred to the new owner until the change of ownership details above have been received.



Enjoy the freedom

ACE CARAVANS, DUNSWELL ROAD, COTTINGHAM, EAST YORKSHIRE HU16 4JX.

TEL: 01482 875740 FAX: 01482 840082

e-mail: enquiry@supercare.co.uk website: www.ace-caravans.co.uk

A MEMBER OF THE SWIFT GROUP

Issued September 2002

1048554