



Bessacarr Owner's Service Handbook



Caravan Details

IMPORTANT Enter all your caravan details on this page (see specification in rear of this handbook).

Model
Model Year
Chassis Number
Key Number
Hitch/Steady Lock Key Number
Internal Length
Overall Length
Overall Width
Maximum External Height
Mass in Running Order
User Payload
Maximum Technical Permissible Laden Mass
Nose Weight
Awning Size
Tyre Pressures/Size

Supplied and Pre-delivery Inspection by:

Service History

Signed/Dealer

Date



CONTENTS

Annual Service/Inspection Record	2
Warranty.....	5
Specifications.....	6
Wiring Diagrams – Road Lights	7
Wiring Diagrams – Internal Wiring	8
Bulb Replacement	10
Change of Ownership	

TOURING CARAVANS - ANNUAL SERVICE/INSPECTION RECORD

In order to comply with the warranty, you must have your caravan inspected and serviced by an authorised Swift Group Service Centre at least once per year.

It is important that the Owner's Handbook is stamped on the appropriate page by the authorised Swift Group Service Centre. Failure to do this will invalidate the warranty and the transfer of the warranty on the change of ownership.

The inspection should take approximately two to four hours and will cover the areas dealt with in the annual service check list. Any areas requiring service and/or maintenance will be highlighted by your dealer and we recommend that you authorise any necessary work to be carried out.

NB. It is essential, to validate the warranty, that an annual inspection be carried out by an authorised Swift Group Service Centre covering the items listed.

1. Damp and lamination test.
2. Coupling head and breakaway cable.
3. Jockey wheel.
4. Chassis and chassis to body security.
5. Corner steadies.
6. Folding step (if fitted).
7. Tyres and tyre pressures.
8. Torque wheel nuts.
9. Brake rods and linkages.
10. Hub bearings, brakes and brake shoes.
11. Handbrake operation and performance.
12. Suspension and shock absorbers (if fitted).
13. 12N and 12S 7-pin plugs and cables.
14. Road lights, wiring and reflectors.
15. Internal lights and 12V DC system.
16. Water heater - gas and 230V AC (if fitted).
17. Hob, grill and oven (if fitted).
18. Refrigerator 230V AC, 12V DC and gas.
19. Gas system.
20. Water pump, taps and water system.
21. Mains 230V AC system.
22. Windows and fittings.
23. Smoke alarm and battery.
24. Roof lights.
25. Furniture hinges/stays etc.
26. Exterior locks and hinges.
27. Grab handle security.
28. All internal vents.
29. Oil seals.
30. Blinds and fly screens (if fitted).

ANNUAL SERVICE/INSPECTION RECORD

CARAVAN MODEL _____ YEAR _____

CHASSIS NUMBER _____

<p>1st SERVICE</p> <p>DATE:</p> <p>DEALER'S STAMP</p> <p>We certify that an annual service has been carried out in accordance with the handbook.</p>	<p>2nd SERVICE</p> <p>DATE:</p> <p>DEALER'S STAMP</p> <p>We certify that an annual service has been carried out in accordance with the handbook.</p>
<p>3rd SERVICE</p> <p>DATE:</p> <p>DEALER'S STAMP</p> <p>We certify that an annual service has been carried out in accordance with the handbook.</p>	<p>4th SERVICE</p> <p>DATE:</p> <p>DEALER'S STAMP</p> <p>We certify that an annual service has been carried out in accordance with the handbook.</p>

<p>5th SERVICE</p> <p>DATE:</p> <p>DEALER'S STAMP</p> <p>We certify that an annual service has been carried out in accordance with the handbook.</p>	<p>6th SERVICE</p> <p>DATE:</p> <p>DEALER'S STAMP</p> <p>We certify that an annual service has been carried out in accordance with the handbook.</p>
<p>7th SERVICE</p> <p>DATE:</p> <p>DEALER'S STAMP</p> <p>We certify that an annual service has been carried out in accordance with the handbook.</p>	<p>8th SERVICE</p> <p>DATE:</p> <p>DEALER'S STAMP</p> <p>We certify that an annual service has been carried out in accordance with the handbook.</p>
<p>9th SERVICE</p> <p>DATE:</p> <p>DEALER'S STAMP</p> <p>We certify that an annual service has been carried out in accordance with the handbook.</p>	<p>10th SERVICE</p> <p>DATE:</p> <p>DEALER'S STAMP</p> <p>We certify that an annual service has been carried out in accordance with the handbook.</p>

All the illustrations and descriptive matter in this handbook are intended to give a general idea of the caravan. Changing market and supply situations and our policy of continuous product development may prevent us from maintaining the exact specifications detailed in this handbook. We therefore reserve the right to alter specifications as materials and conditions demand.

Dealers are not agents of Swift Group Limited, the manufacturer of Swift Group caravans, and have absolutely no authority to bind the manufacturer by any express or implied undertaking or representation.

All caravans have a 3 year SuperSure warranty from the date of purchase (or hire purchase), which is subject to a chargeable annual service and inspection being carried out at an authorised Swift Group Service Centre.

In the first 12 months this covers faults arising from a manufacturing defect but not those which are a result of normal wear and tear. The manufacturer will honour the warranty until 36 months from the date of sale, and providing that the caravan has been serviced annually within 90 days before or 30 days after the anniversary of the original sale. The third service must, however, be carried out before the expiry of the 36 month period from the original date of sale.

In years two and three the warranty will cover:

- i) All original components of the caravan including permanently fitted equipment forming part of the manufacturer's original specification.
- ii) Water ingress and body delamination.

Specific exclusions to SuperSure warranty:

Tyres, glass, paint, brightwork and all similar trim and finish. Soft furnishings, carpets, floor coverings, work surfaces and all other décor. Window catches, stays and associated fittings. Adjustments of brakes, blinds, hinges, catches, stays and doors. Replacement of bulbs, fluorescent tubes, fuses and electrical connections. Natural movement of internal doors and furniture. Audio equipment. Fair wear and tear.

The warranty will be invalidated if the caravan has been neglected, misused or modified. The warranty on all internal components will be invalidated if the caravan has been used for hire or reward. The caravan will be deemed to have been neglected if it has not been serviced and maintained as stated in this handbook.

The warranty only applies to caravans purchased and used within the UK, and for continuous journeys abroad of no longer than 90 days per journey.

The cost of transporting, towing or moving the caravan by any means to or from the place of repair is the responsibility of the owner.

The benefit of this warranty may be transferred to a new owner if the caravan is sold, provided that the caravan has been serviced by an authorised service centre in accordance with the requirements of this handbook, and details of the change of ownership have been supplied to Swift using the change of ownership form set out in this handbook. Failure to notify Swift of a change of ownership within 14 days of such change will invalidate the warranty.

This warranty only applies to caravans purchased in the UK.

The above conditions in no way affect your statutory rights in respect of the caravan.

Specifications

CAMEO	495SL	525SL	550GL	625GL
Berths	2	3 opt 4	3 opt 4	4
Internal Length (bed box height)	5.09m/16'8"	5.36m/17'7"	5.85/19'2"	6.35m/20'10"
Overall Width	2.23m/7'4"	2.23m/7'4"	2.23m/7'4"	2.23m/7'4"
Overall Height (inc. TV Aerial)	2.80m/9'2"	2.80m/9'2"	2.71m/8'11"	2.71m/8'11"
Overall Length	6.68m/21'11"	6.96m/22'10"	7.45m/24'5"	7.95m/26'1"
Mass in Running Order (inc. tolerance)	1346kg/26.5cwt	1408kg/27.7cwt	1463kg/28.8cwt	1564kg/30.8cwt
Essential Habitation Equipment Payload	115kg/2.3cwt	115kg/2.3cwt	115kg/2.3cwt	115kg/2.3cwt
Personal Effects Payload	108kg/2.1cwt	130kg/2.6cwt	135kg/2.7cwt	140kg/2.8cwt
Optional Equipment Payload	27kg/0.5cwt	47kg/0.9cwt	47kg/0.9cwt	27kg/0.5cwt
Maximum Technical Permissible Laden Mass (DECLARED)	1596kg/31.4cwt	1700kg/33.5cwt	1760kg/34.6cwt	1846kg/36.3cwt
Maximum Technical Permissible Laden Mass (POSSIBLE)	1600kg/31.5cwt	1700kg/33.5cwt	1800kg/35.4cwt	1900kg/37.4cwt
Awning A/A dimension	9.42/30'11"	9.69m/31'9"	10.18m/33'5"	10.68m/35'0"
Tyre Size	195/70 R15 104	195/70 R15 104	165 R13 82	165 R13 82
Tyre pressure at DECLARED MTPLM	52psi	58psi	33psi	33psi
Tyre pressure at POSSIBLE MTPLM	52psi	65psi	33psi	33psi
Static Load on Coupling Head	100kg	100kg	100kg	100kg
Thermal Insulation & Heating Grade	TWO	TWO	TWO	TWO
Bed Sizes				
Front Double	205cm x 188cm/ 6'9" x 6'2"	205cm x 177cm/ 6'9" x 5'10"	205cm x 188cm/ 6'9" x 6'2"	205cm x 177cm/ 6'9" x 5'10"
or one Single	188cm x 71cm/ 6'2" x 2'4"	177cm x 71cm/ 5'10" x 2'4"	188cm x 71cm/ 6'2" x 2'4"	177cm x 71cm/ 5'10" x 2'4"
and one Single	188cm x 71cm/ 6'2" x 2'4"	188cm x 71cm/ 6'2" x 2'4"	188cm x 71cm/ 6'2" x 2'4"	188cm x 71cm/ 6'2" x 2'4"
Rear Double				190cm x 137cm/ 6'3" x 4'6"
Side Single		180cm x 66cm/ 5'11" x 2'2"	180cm x 66cm/ 5'11" x 2'2"	
Optional Bunk		172cm x 56cm/ 5'8" x 1'10"	172cm x 56cm/ 5'8" x 1'10"	

Please note that double bed sizes are quoted with wrap round seating

CAMEO RANGE 2003 - ROAD LIGHTS

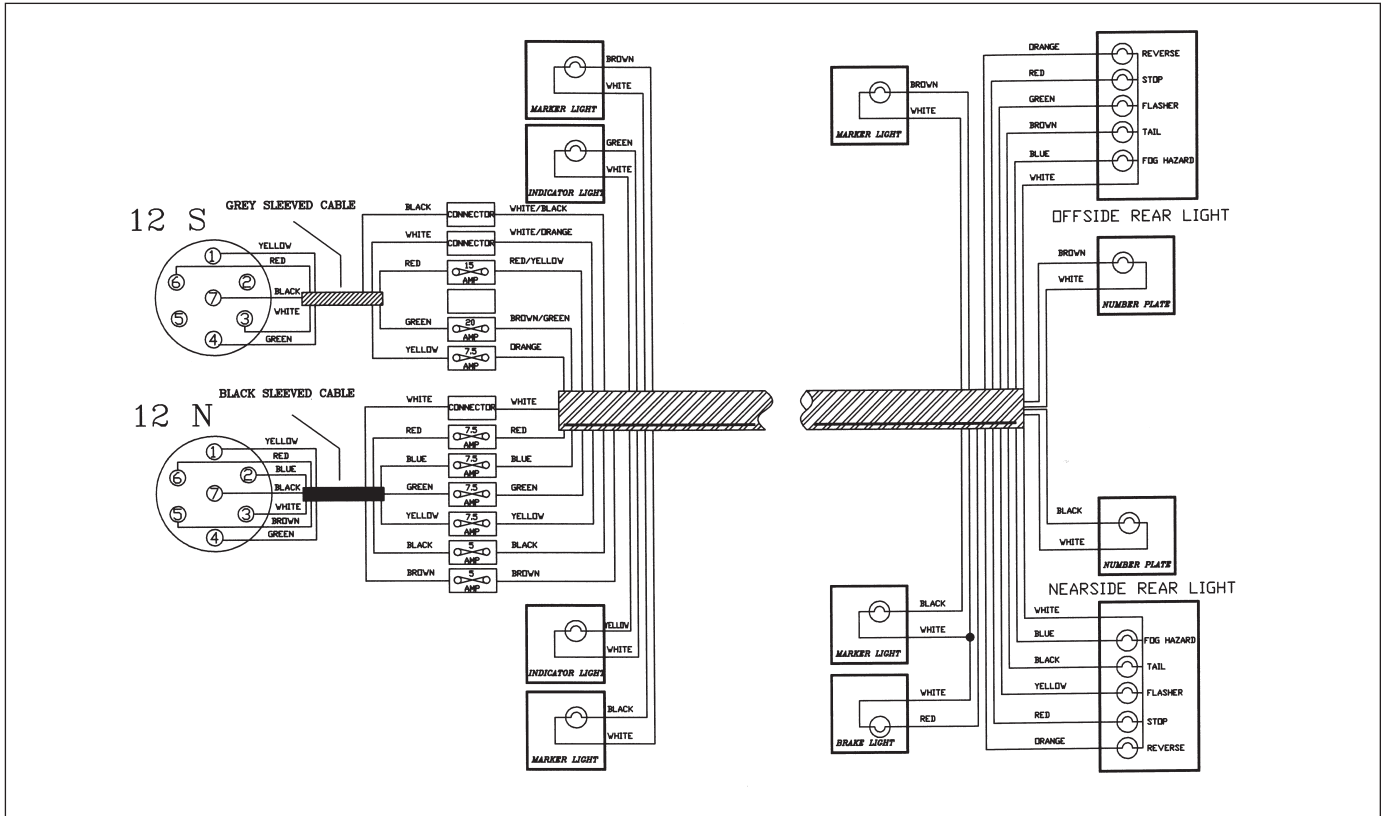

Wiring Diagrams

CAMEO 495SL AND 525SL 2003 - 12V AND 230V

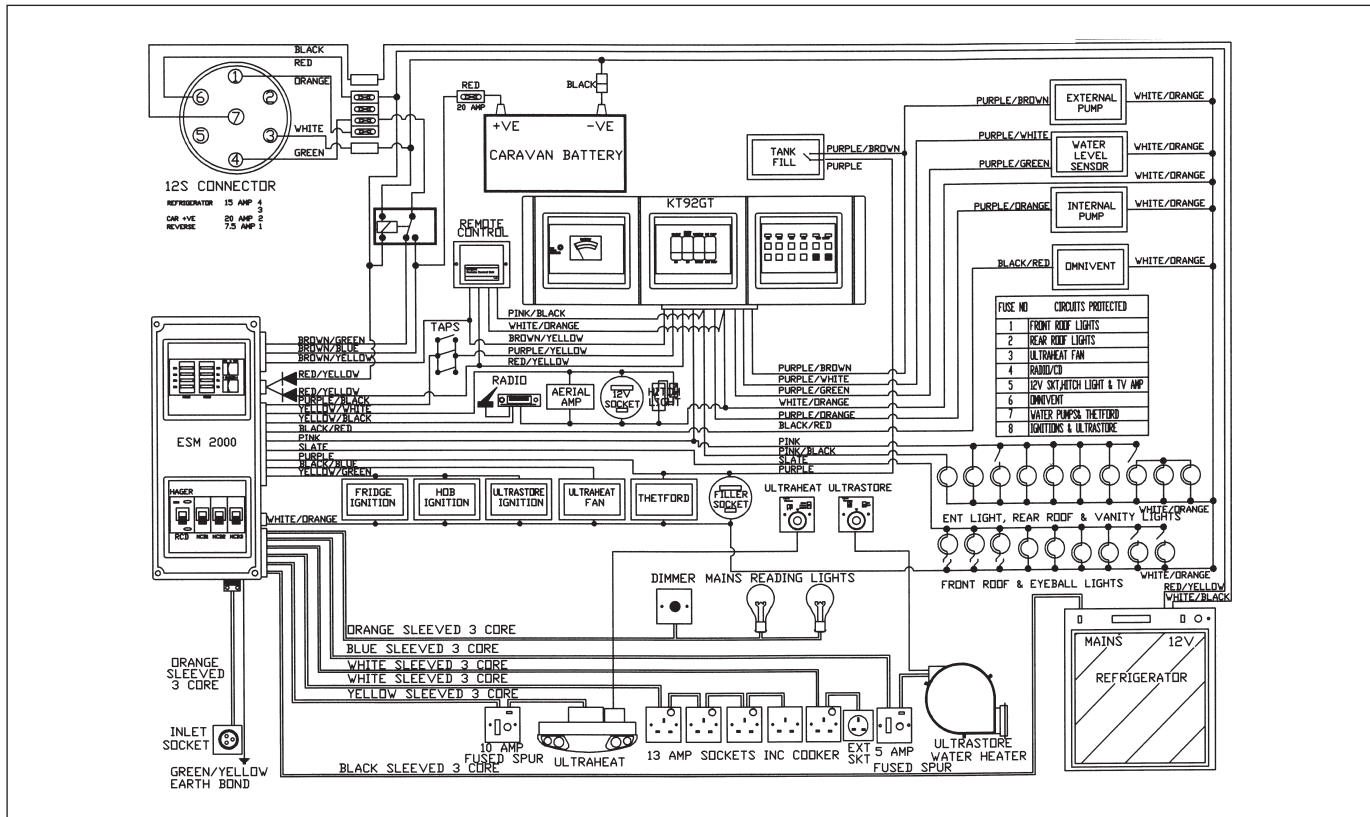

Bulb Replacement

	TYPE	POWER	CAMEO		
ROAD LIGHTS					
Front marker lights	W501W	12v 3w	✓		
Side marker	F239	12v 5w	✓		
Reversing light	L382	12v 21w	✓		
Rear indicator light	L382	12v 21w	✓		
Brake / tail light	L380	12v 21w / 5w	✓		
Fog light	L382	12v 21w	✓		
Number plate light	F239	12v 5w	✓		
High level brake light	Capless	12v 2.3w	✓		
Hitch cover light	F239	12v 5w	✓		
INTERIOR/OTHER					
Awning (Internal switch)	P21W	12v 20w	✓		
Reading lights	Halogen capsule	G4 12v 10w	✓		
Ceiling lights	Halogen capsule	G4 12v 10w	✓		
Spotlights	Dichroic	12v 10w	✓		
Step light	Halogen capsule	G4 12v 5w	✓		
Mains lights	Small screw	240v 40w	✓		

Note: Not all lights and bulbs feature on all models within a range

NOTIFICATION OF CHANGE OF OWNERSHIP

If you sell your caravan, please notify the change of ownership by completing this page, detaching it and sending it to:
Swift Group Ltd., Dunswell Road, Cottingham, East Yorkshire, HU16 4JX.

DETAILS OF CARAVAN:	Model:	_____
	Chassis No:	_____
CURRENT OWNER:	Name:	_____
	Address:	_____

NEW OWNER:	Name:	_____
	Address:	_____

Please note that the benefit of any unexpired warranty cannot be transferred to the new owner until the change of ownership details above have been received.



Individually Styled ~ Beautifully Built

Bessacarr Caravans, Dunswell Road,
Cottingham, East Yorkshire HU16 4JX.
Tel: 01482 875740 Fax: 01482 840082

e-mail: enquiry@supercare.co.uk website: www.bessacarrcaravans.co.uk

A MEMBER OF THE SWIFT GROUP

Issued September 2002

1048553