

Sterling Owner's

Service Handbook



Caravan Details

IMPORTANT Enter all your caravan details on this page (see specification in rear of this handbook).

Model
Model Year
Chassis Number
Key Number
Hitch/Steady Lock Key Number
Internal Length
Overall Length
Overall Width
Maximum External Height
Mass in Running Order
User Payload
Maximum Technical Permissible Laden Mass
Nose Weight
Awning Size
Tyre Pressures/Size

Supplied and Pre-delivery Inspection by:
--

Service History	
Signed/Dealer	Date



CONTENTS

Annual Service/Inspection Record	2
Warranty.....	5
Specifications.....	6
Wiring Diagrams – Road Lights	9
Wiring Diagrams – Internal Wiring	12
Bulb Replacement	15
Change of Ownership	

TOURING CARAVANS - ANNUAL SERVICE/INSPECTION RECORD

In order to comply with the warranty, you must have your caravan inspected and serviced by an authorised Swift Group Service Centre at least once per year.

It is important that the Owner's Handbook is stamped on the appropriate page by the authorised Swift Group Service Centre. Failure to do this will invalidate the warranty and the transfer of the warranty on the change of ownership.

The inspection should take approximately two to four hours and will cover the areas dealt with in the annual service check list. Any areas requiring service and/or maintenance will be highlighted by your dealer and we recommend that you authorise any necessary work to be carried out.

NB. It is essential, to validate the warranty, that an annual inspection be carried out by an authorised Swift Group Service Centre covering the items listed.

1. Damp and lamination test.
2. Coupling head and breakaway cable.
3. Jockey wheel.
4. Chassis and chassis to body security.
5. Corner steadies.
6. Folding step (if fitted).
7. Tyres and tyre pressures.
8. Torque wheel nuts.
9. Brake rods and linkages.
10. Hub bearings, brakes and brake shoes.
11. Handbrake operation and performance.
12. Suspension and shock absorbers (if fitted).
13. 12N and 12S 7-pin plugs and cables.
14. Road lights, wiring and reflectors.
15. Internal lights and 12V DC system.
16. Water heater - gas and 230V AC (if fitted).
17. Hob, grill and oven (if fitted).
18. Refrigerator 230V AC, 12V DC and gas.
19. Gas system.
20. Water pump, taps and water system.
21. Mains 230V AC system.
22. Windows and fittings.
23. Smoke alarm and battery.
24. Roof lights.
25. Furniture hinges/stays etc.
26. Exterior locks and hinges.
27. Grab handle security.
28. All internal vents.
29. Oil seals.
30. Blinds and fly screens (if fitted).

ANNUAL SERVICE/INSPECTION RECORD

CARAVAN MODEL _____ YEAR _____

CHASSIS NUMBER _____

<p>1st SERVICE</p> <p>DATE:</p> <p>DEALER'S STAMP</p> <p>We certify that an annual service has been carried out in accordance with the handbook.</p>	<p>2nd SERVICE</p> <p>DATE:</p> <p>DEALER'S STAMP</p> <p>We certify that an annual service has been carried out in accordance with the handbook.</p>
<p>3rd SERVICE</p> <p>DATE:</p> <p>DEALER'S STAMP</p> <p>We certify that an annual service has been carried out in accordance with the handbook.</p>	<p>4th SERVICE</p> <p>DATE:</p> <p>DEALER'S STAMP</p> <p>We certify that an annual service has been carried out in accordance with the handbook.</p>

<p>5th SERVICE</p> <p>DATE:</p> <p>DEALER'S STAMP</p> <p>We certify that an annual service has been carried out in accordance with the handbook.</p>	<p>6th SERVICE</p> <p>DATE:</p> <p>DEALER'S STAMP</p> <p>We certify that an annual service has been carried out in accordance with the handbook.</p>
<p>7th SERVICE</p> <p>DATE:</p> <p>DEALER'S STAMP</p> <p>We certify that an annual service has been carried out in accordance with the handbook.</p>	<p>8th SERVICE</p> <p>DATE:</p> <p>DEALER'S STAMP</p> <p>We certify that an annual service has been carried out in accordance with the handbook.</p>
<p>9th SERVICE</p> <p>DATE:</p> <p>DEALER'S STAMP</p> <p>We certify that an annual service has been carried out in accordance with the handbook.</p>	<p>10th SERVICE</p> <p>DATE:</p> <p>DEALER'S STAMP</p> <p>We certify that an annual service has been carried out in accordance with the handbook.</p>

All the illustrations and descriptive matter in this handbook are intended to give a general idea of the caravan. Changing market and supply situations and our policy of continuous product development may prevent us from maintaining the exact specifications detailed in this handbook. We therefore reserve the right to alter specifications as materials and conditions demand.

Dealers are not agents of Swift Group Limited, the manufacturer of Swift Group caravans, and have absolutely no authority to bind the manufacturer by any express or implied undertaking or representation.

All caravans have a 3 year SuperSure warranty from the date of purchase (or hire purchase), which is subject to a chargeable annual service and inspection being carried out at an authorised Swift Group Service Centre.

In the first 12 months this covers faults arising from a manufacturing defect but not those which are a result of normal wear and tear. The manufacturer will honour the warranty until 36 months from the date of sale, and providing that the caravan has been serviced annually within 90 days before or 30 days after the anniversary of the original sale. The third service must, however, be carried out before the expiry of the 36 month period from the original date of sale.

In years two and three the warranty will cover:

- i) All original components of the caravan including permanently fitted equipment forming part of the manufacturer's original specification.
- ii) Water ingress and body delamination.

Specific exclusions to SuperSure warranty:

Tyres, glass, paint, brightwork and all similar trim and finish. Soft furnishings, carpets, floor coverings, work surfaces and all other décor. Window catches, stays and associated fittings. Adjustments of brakes, blinds, hinges, catches, stays and doors. Replacement of bulbs, fluorescent tubes, fuses and electrical connections. Natural movement of internal doors and furniture. Audio equipment. Fair wear and tear.

The warranty will be invalidated if the caravan has been neglected, misused or modified. The warranty on all internal components will be invalidated if the caravan has been used for hire or reward. The caravan will be deemed to have been neglected if it has not been serviced and maintained as stated in this handbook.

The warranty only applies to caravans purchased and used within the UK, and for continuous journeys abroad of no longer than 90 days per journey.

The cost of transporting, towing or moving the caravan by any means to or from the place of repair is the responsibility of the owner.

The benefit of this warranty may be transferred to a new owner if the caravan is sold, provided that the caravan has been serviced by an authorised service centre in accordance with the requirements of this handbook, and details of the change of ownership have been supplied to Swift using the change of ownership form set out in this handbook. Failure to notify Swift of a change of ownership within 14 days of such change will invalidate the warranty.

This warranty only applies to caravans purchased in the UK.

The above conditions in no way affect your statutory rights in respect of the caravan.

Specifications

EUROPA	390	460	480	490	500L	510	520
Berths	2	2	2	4	5	5	4
Internal Length (bed box height)	3.94m/12'11"	4.61m/15'2"	4.61m/15'2"	5.09m/16'8"	5.03m/16'6"	5.03m/16'6"	5.23m/17'2"
Overall Width	2.16m/7'1"	2.16m/7'1"	2.16m/7'1"	2.23m/7'4"	2.16m/7'1"	2.16m/7'1"	2.16m/7'1"
Overall Height (inc. TV Aerial)	2.76m/9'1"	2.76m/9'1"	2.76m/9'1"	2.76m/9'1"	2.76m/9'1"	2.76m/9'1"	2.76m/9'1"
Overall Length	5.53m/18'2"	6.21m/20'4"	6.21m/20'4"	6.68m/21'11"	6.62m/21'9"	6.62m/21'9"	6.83m/22'5"
Mass in Running Order (inc. 3% tolerance)	902kg/17.8cwt	977kg/19.2cwt	986kg/19.4cwt	1070kg/21.1cwt	1067kg/21.0cwt	1061kg/20.9cwt	1095kg/21.5cwt
Essential Habitation Equipment Payload	90kg/1.8cwt	82kg/1.6cwt	82kg/1.6cwt	82kg/1.6cwt	90kg/1.8cwt	90kg/1.8cwt	82kg/1.6cwt
Personal Effects Payload	96kg/1.9cwt	103kg/2.0cwt	103kg/2.0cwt	128kg/2.5cwt	137kg/2.7cwt	137kg/2.7cwt	129kg/2.5cwt
Optional Equipment Payload	22kg/0.4cwt	48kg/1.0cwt	49kg/1.0cwt	50kg/1.0cwt	51kg/1.0cwt	52kg/1.0cwt	49kg/1.0cwt
Maximum Technical Permissible Laden Mass (DECLARED)	1110kg/21.8cwt	1210kg/23.8cwt	1220kg/24.0cwt	1330kg/26.2cwt	1345kg/26.5cwt	1340kg/26.4cwt	1355kg/26.7cwt
Maximum Technical Permissible Laden Mass (POSSIBLE)	1230kg/24.2cwt	1230kg/24.2cwt	1230kg/24.2cwt	1350kg/26.6cwt	1350kg/26.6cwt	1350kg/26.6cwt	1500kg/29.5cwt
Awning A/A dimension	8.15m/26'9"	8.82m/28'11"	8.82m/28'11"	9.30m/30'6"	9.24m/30'4"	9.24m/30'4"	9.44m/31'0"
Tyre Size	195/70R14 91	195/70R14 91	195/70R14 91	195/70R14 95	195/70R14 95	195/70R14 95	175R14 99
Tyre pressure at DECLARED MTPLM	33psi	36psi	36psi	42psi	42psi	42psi	54psi
Tyre pressure at POSSIBLE MTPLM	36psi	36psi	36psi	42psi	42psi	42psi	65psi
Static Load on Coupling Head	100kg	100kg	100kg	100kg	100kg	100kg	100kg
Thermal Insulation & Heating Grade	TWO	TWO	TWO	TWO	TWO	TWO	TWO
Bed Sizes							
Front Double	204cm x 190cm 6'8" x 6'3"	204cm x 180cm 6'8" x 5'11"	204cm x 139cm 6'8" x 4'7"	211cm x 155cm 6'11" x 5'1"	204cm x 190cm 6'8" x 6'3"	204cm x 190cm 6'8" x 6'3"	204cm x 180cm 6'8" x 5'11"
or One Single	190cm x 69cm 6'3" x 2'3"	190cm x 69cm 6'3" x 2'3"	190cm x 69cm 6'3" x 2'3"		190cm x 69cm 6'3" x 2'3"	190cm x 69cm 6'3" x 2'3"	190cm x 69cm 6'3" x 2'3"
and One Single	190cm x 69cm 6'3" x 2'3"	180cm x 69cm 5'11" x 2'3"	190cm x 71cm 6'3" x 2'4"	187cm x 137cm 6'2" x 4'6"	190cm x 69cm 6'3" x 2'3"	190cm x 69cm 6'3" x 2'3"	180cm x 69cm 5'11" x 2'3"
Rear Double					204cm x 116cm 6'8" x 3'10"	204cm x 116cm 6'8" x 3'10"	
Rear Bunk					198cm x 56cm 6'6" x 1'10"	198cm x 56cm 6'6" x 1'10"	180cm x 66cm 5'11" x 2'2"
Side Single							172cm x 58cm 5'8" x 1'11"
Side Bunk							

Please note that double bed sizes are quoted with wrap round seating

Specifications

ECCLES	JADE	AMBER	TOPAZ	ONYX	MOONSTONE	EMERALD	AMETHYST	SAPPHIRE	JEWEL
Berths	2	2	2	4	4	4	5	5	4
Internal Length (bed box height)	3.94m/12'11"	4.61m/15'2"	4.61m/15'2"	5.09m/16'8"	5.23m/17'2"	5.23m/17'2"	5.23m/17'2"	5.23m/17'2"	5.50m/18'1"
Overall Width	2.16m/7'1"	2.16m/7'1"	2.16m/7'1"	2.23m/7'4"	2.16m/7'1"	2.16m/7'1"	2.16m/7'1"	2.16m/7'1"	2.23m/7'4"
Overall Height (inc. TV Aerial)	2.76m/9'1"	2.76m/9'1"	2.76m/9'1"	2.76m/9'1"	2.76m/9'1"	2.76m/9'1"	2.76m/9'1"	2.76m/9'1"	2.76m/9'1"
Overall Length	5.52m/18'1"	6.20m/20'4"	6.20m/20'4"	6.67m/21'11"	6.81m/22'4"	6.81m/22'4"	6.81m/22'4"	6.81m/22'4"	7.09m/23'3"
Mass in Running Order (inc. 3% tolerance)	954kg/18.8cwt	1052kg/20.7cwt	1056kg/20.8cwt	1122kg/22.1cwt	1166kg/23.0cwt	1166kg/23.0cwt	1157kg/22.8cwt	1175kg/23.1cwt	1226kg/24.1cwt
Essential Habitation Equipment Payload	90kg/1.8cwt	82kg/1.6cwt	82kg/1.6cwt	82kg/1.6cwt	82kg/1.6cwt	82kg/1.6cwt	90kg/1.8cwt	90kg/1.8cwt	82kg/1.6cwt
Personal Effects Payload	96kg/1.9cwt	103kg/2.0cwt	103kg/2.0cwt	128kg/2.5cwt	129kg/2.5cwt	129kg/2.5cwt	139kg/2.7cwt	139kg/2.7cwt	132kg/2.6cwt
Optional Equipment Payload	50kg/1.0cwt	48kg/0.9cwt	49kg/1.0cwt	18kg/0.4cwt	48kg/0.9cwt	48kg/0.9cwt	49kg/1.0cwt	46kg/0.9cwt	46kg/0.9cwt
Maximum Technical Permissible Laden Mass (DECLARED)	1190kg/24.3cwt	1285kg/25.3cwt	1290kg/25.4cwt	1350kg/26.6cwt	1425kg/28.1cwt	1425kg/28.1cwt	1435kg/28.2cwt	1450kg/28.5cwt	1486kg/29.2cwt
Maximum Technical Permissible Laden Mass (POSSIBLE)	1230kg/24.2cwt	1350kg/26.6cwt	1350kg/26.6cwt	1350kg/26.6cwt	1500kg/29.5cwt	1500kg/29.5cwt	1500kg/29.5cwt	1500kg/29.5cwt	1500kg/29.5cwt
Awning A/A dimension	8.15m/26'9"	8.82m/28'11"	8.82m/28'11"	9.30m/30'6"	9.44m/31'0"	9.44m/31'0"	9.44m/31'0"	9.44m/31'0"	9.71m/31'10"
Tyre Size	195/70R14 91	195/70R14 95	195/70R14 95	195/70R14 95	175R14 99	175R14 99	175R14 99	175R14 99	175R14 99
Tyre pressure at DECLARED MTPLM	35psi	39psi	39psi	42psi	54psi	54psi	58psi	62psi	62psi
Tyre pressure at POSSIBLE MTPLM	36psi	42psi	42psi	42psi	65psi	65psi	65psi	65psi	65psi
Static Load on Coupling Head	100kg	100kg	100kg	100kg	100kg	100kg	100kg	100kg	100kg
Thermal Insulation & Heating Grade	TWO	TWO	TWO	TWO	TWO	TWO	TWO	TWO	TWO
Bed Sizes									
Front Double	204cm x 190cm 6'8" x 6'3"	204cm x 139cm 6'8" x 4'7"	204cm x 190cm 6'8" x 6'3"	208cm x 151cm 6'10" x 4'11"	204cm x 180cm 6'8" x 5'11"	204cm x 139cm 6'8" x 4'7"	204cm x 137cm 6'8" x 4'6"	204cm x 190cm 6'8" x 6'3"	208cm x 158cm 6'10" x 5'2"
or One Single	190cm x 67cm 6'3" x 2'2"	190cm x 67cm 6'3" x 2'2"	190cm x 67cm 6'3" x 2'2"		190cm x 67cm 6'3" x 2'2"	190cm x 67cm 6'3" x 2'2"		190cm x 67cm 6'3" x 2'2"	
and One Single	190cm x 67cm 6'3" x 2'2"	190cm x 71cm 6'3" x 2'4"	190cm x 67cm 6'3" x 2'2"	198cm x 138cm 6'6" x 4'6"	180cm x 67cm 5'11" x 2'2"	190cm x 71cm 6'3" x 2'4"	204cm x 132cm 6'8" x 4'4"	190cm x 67cm 6'3" x 2'2"	197cm x 137cm 6'6" x 4'6"
Rear Double							204cm x 58cm 6'8" x 1'11"	188cm x 132cm 6'2" x 4'4"	
Rear Bunk					180cm x 66cm 5'11" x 2'2"	180cm x 66cm 5'11" x 2'2"		188cm x 58cm 6'2" x 1'11"	
Side Single					178cm x 56cm 5'10" x 1' 10"	178cm x 56cm 5'10" x 1' 10"			
Side Bunk									

Please note that double bed sizes are quoted with wrap round seating

Specifications

ECCLES ELITE	WAYFARER	SEARCHER	TREKKER	EXPLORER
Berths	5	4	5 opt 6	4
Internal Length (bed box height)	6.35m/20'10"	6.35m/20'10"	6.35m/20'10"	6.35m/20'10"
Overall Width	2.23m/7'4"	2.23m/7'4"	2.23m/7'4"	2.23m/7'4"
Overall Height (inc. TV Aerial)	2.75m/9'0"	2.75m/9'0"	2.75m/9'0"	2.75m/9'0"
Overall Length	7.95m/26'1"	7.95m/26'1"	7.95m/26'1"	7.95m/26'1"
Mass in Running Order (inc. 3% tolerance)	1415kg/27.8cwt	1436kg/28.3cwt	1425kg/28.1cwt	1447kg/28.5cwt
Essential Habitation Equipment Payload	115kg/2.3cwt	115kg/2.3cwt	123kg/2.4cwt	115kg/2.3cwt
Personal Effects Payload	150kg/3.0cwt	140kg/2.8cwt	160kg/3.2cwt	140kg/2.8cwt
Optional Equipment Payload	50kg/1.0cwt	44kg/0.9cwt	52kg/1.0cwt	44kg/0.9cwt
Maximum Technical Permissible Laden Mass (DECLARED)	1730kg/34.1cwt	1735kg/34.2cwt	1760kg/34.6cwt	1746kg/34.4cwt
Maximum Technical Permissible Laden Mass (POSSIBLE)	1800kg/35.4cwt	1800kg/35.4cwt	1800kg/35.4cwt	1800kg/35.4cwt
Awning A/A dimension	10.48m/34'5"	10.48m/34'5"	10.48m/34'5"	10.48m/34'5"
Tyre Size	165R13 83	165R13 83	165R13 83	165R13 83
Tyre pressure at DECLARED MTPLM	33psi	33psi	33psi	33psi
Tyre pressure at POSSIBLE MTPLM	33psi	33psi	33psi	33psi
Static Load on Coupling Head	100kg	100kg	100kg	100kg
Thermal Insulation & Heating Grade	TWO	TWO	TWO	TWO
Bed Sizes				
Front Double	208cm x 190cm/6'8" x 6'3"	208cm x 180cm/6'8" x 5'11"	208cm x 190cm/6'8" x 6'3"	208cm x 180cm/6'8" x 5'11"
or One Single	190cm x 71cm/6'3" x 2'4"	190cm x 71cm/6'3" x 2'4"	190cm x 71cm/6'3" x 2'4"	180cm x 71cm/5'11" x 2'4"
and One Single	190cm x 71cm/6'3" x 2'4"	182cm x 71cm/6'0" x 2'4"	190cm x 71cm/6'3" x 2'4"	190cm x 71cm/6'3" x 2'4"
Rear Double	192cm x 138cm/6'4" x 4'6"	192cm x 138cm/6'4" x 4'6"	205cm x 137cm/6'9" x 4'6"	202cm x 145cm/6'6" x 4'9"
Rear Bunk	184cm x 56cm/5'11" x 1'10"			
Side Single (O/S)			177cm x 68cm/ 5'10" x 2'3"	
Side Single (NS)			177cm x 68cm/ 5'10" x 2'3"	
Side Bunk			172cm x 56cm/5'8" x 1'10"	
Optional Bunk			172cm x 56cm/5'8" x 1'10"	
Side Double				

Please note that double bed sizes are quoted with wrap round seating

EUROPA RANGE 2002 - ROAD LIGHTS

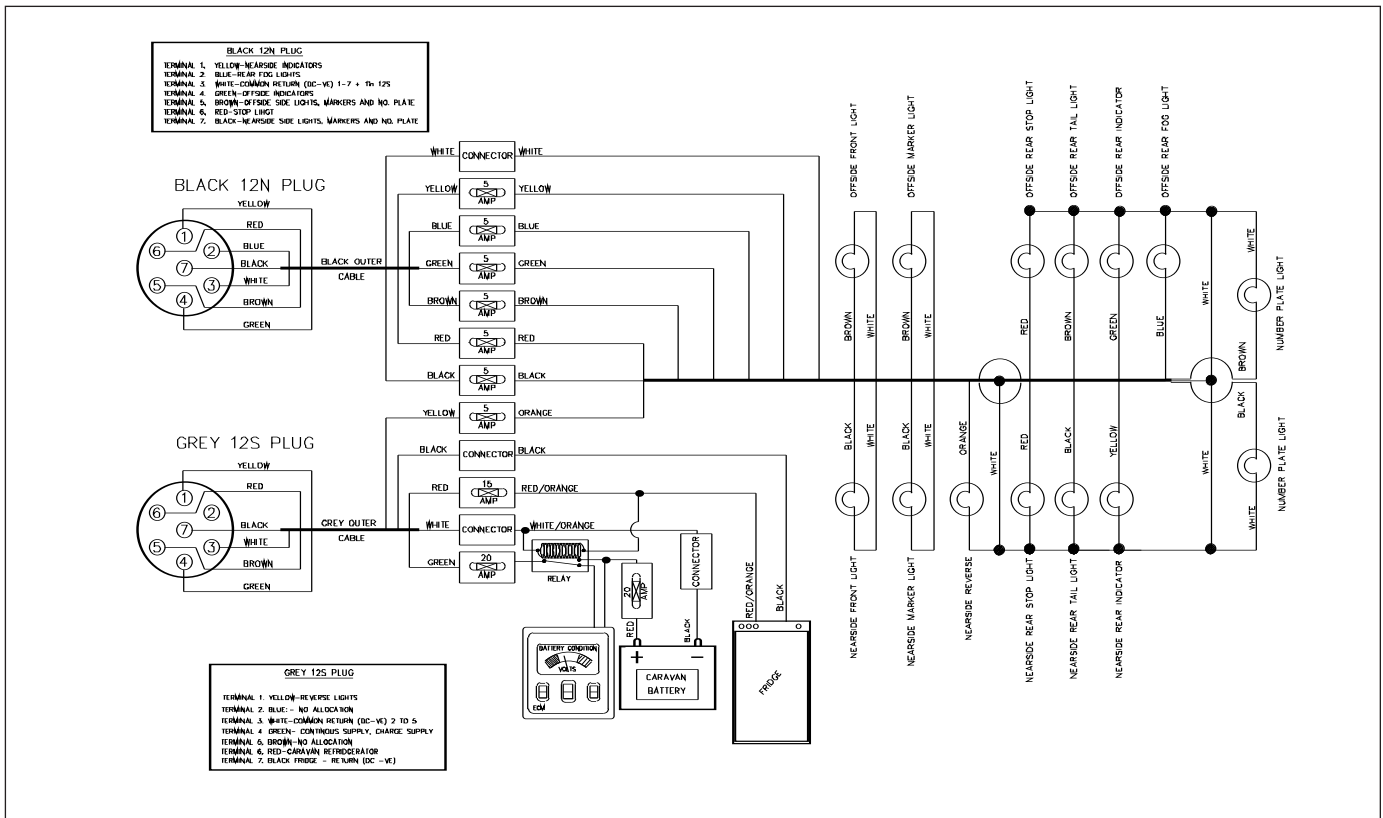

Wiring Diagrams

ECCLES RANGE 2002 - ROAD LIGHTS

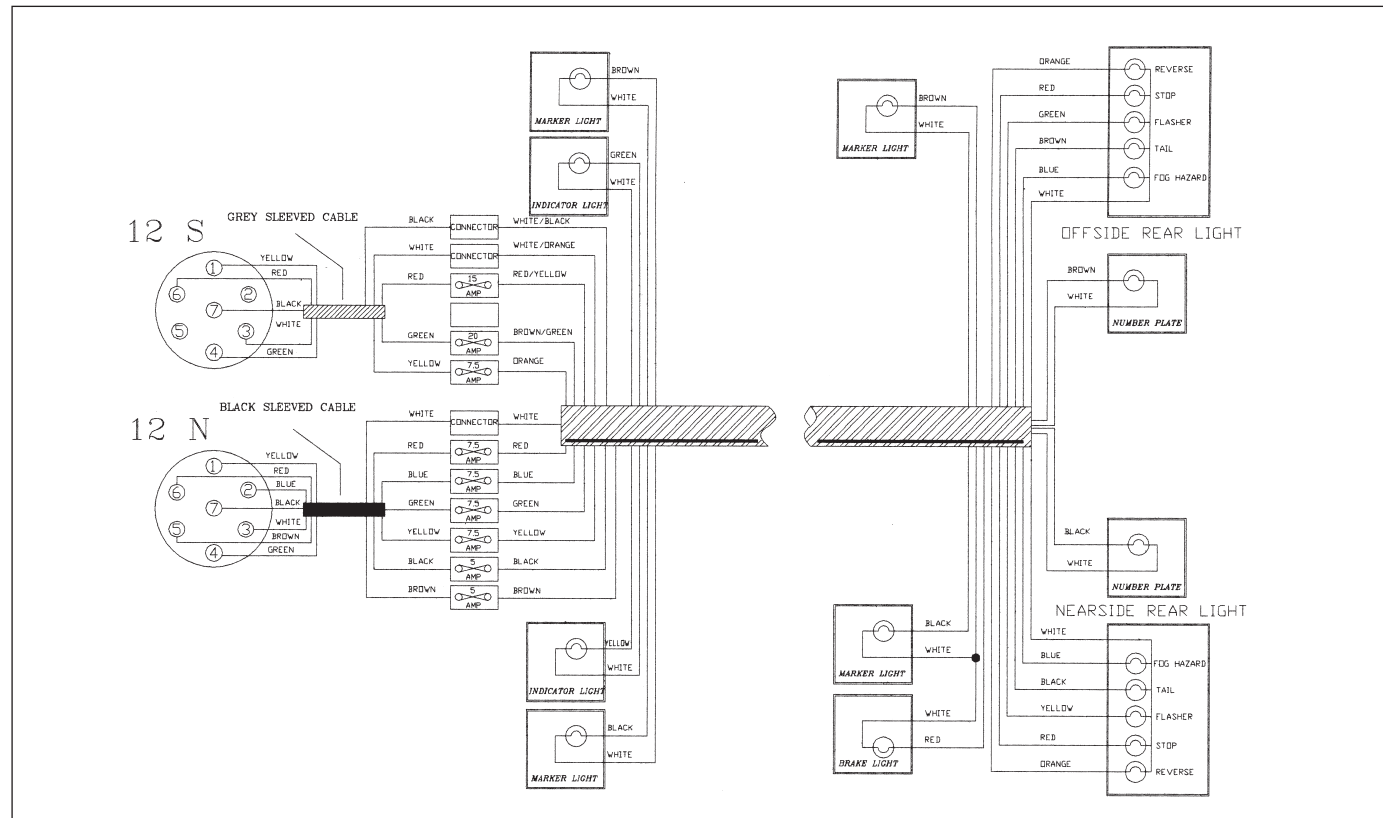

ECCLES ELITE RANGE 2002 - ROAD LIGHTS

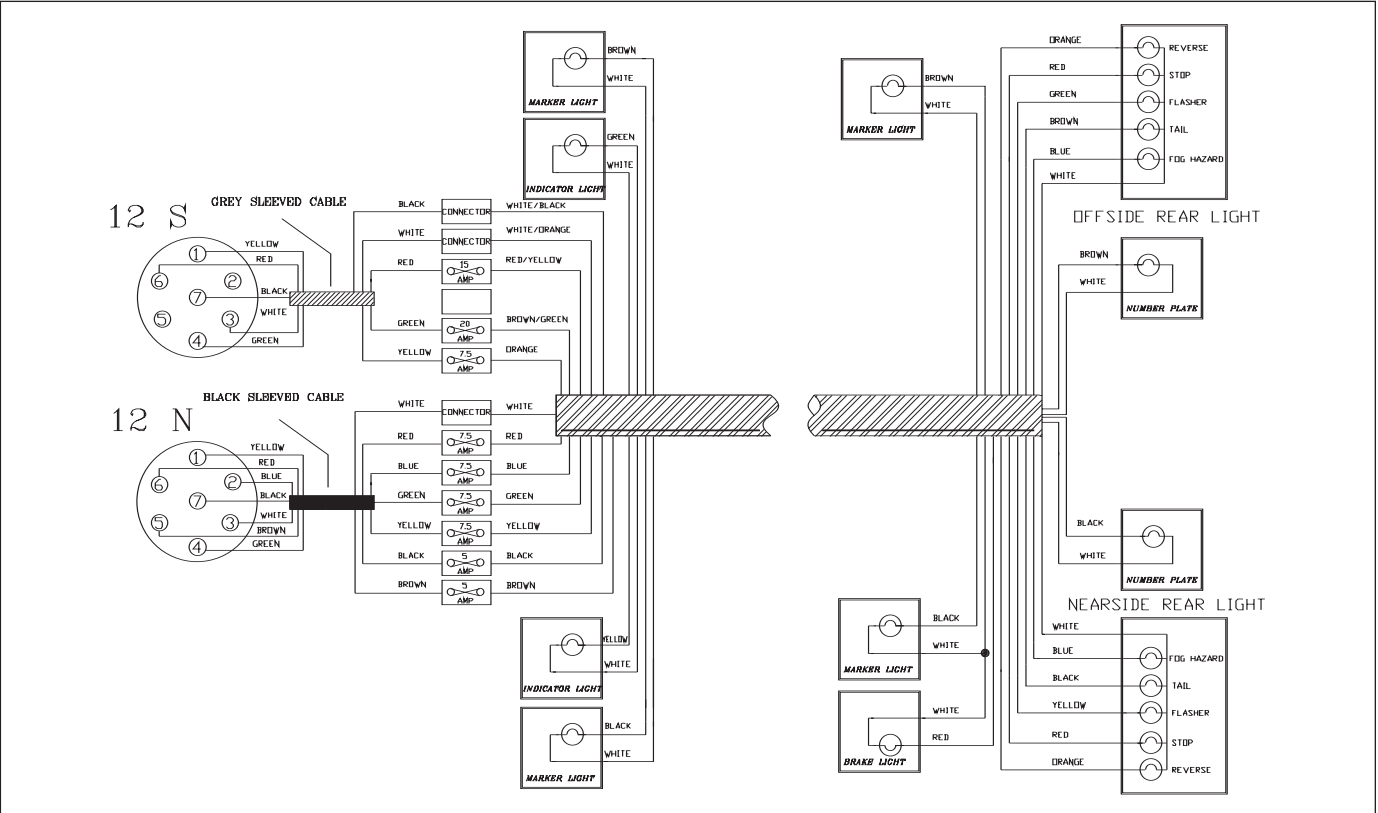

Wiring Diagrams

ECCLES ELITE RANGE 2002 - 12V AND 230V

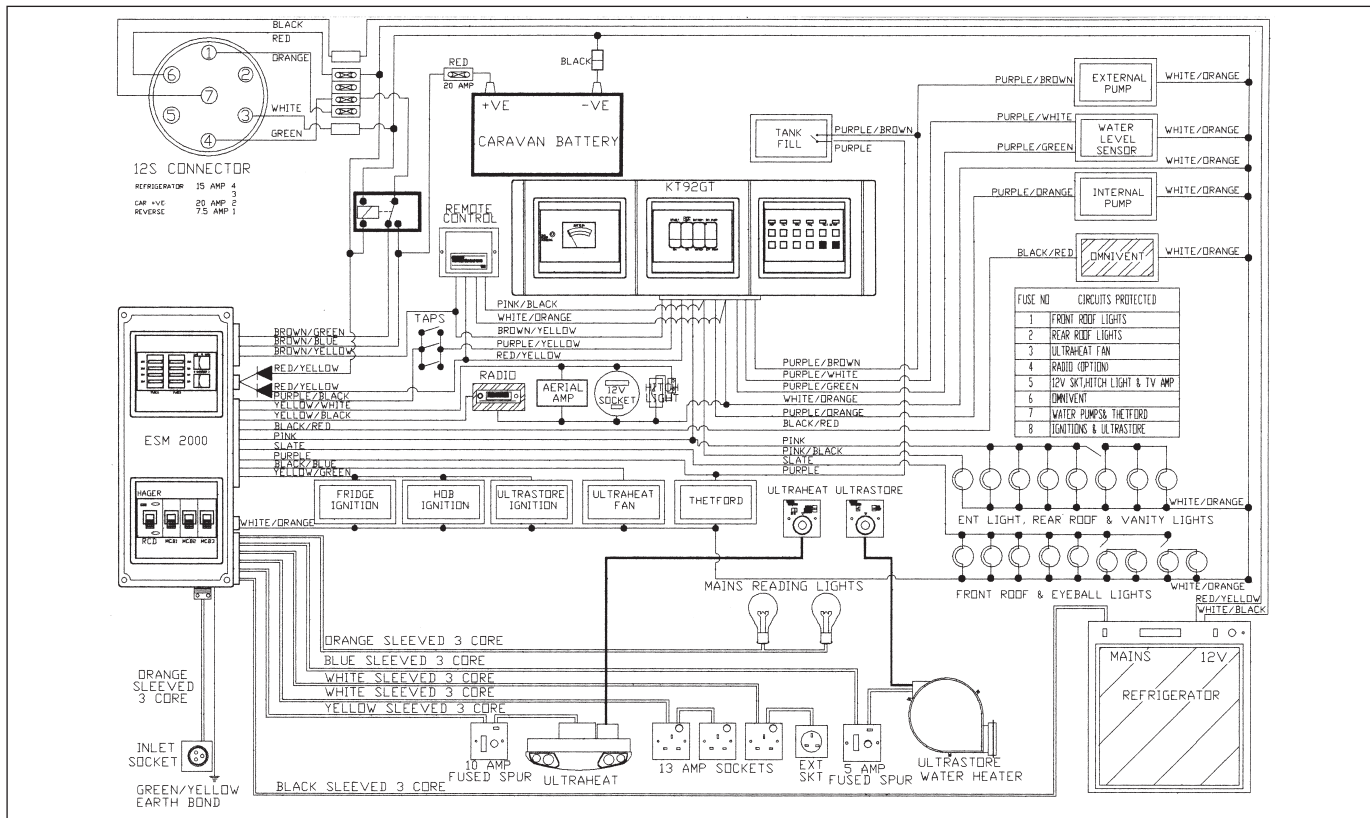

Bulb Replacement

	TYPE	POWER	SPECIAL EDITION	EUROPA	ECCLES	ECCLES ELITE
ROAD LIGHTS						
Front marker lights	W501	12V 3W	✓			
Front marker lights	F239	12V 5W		✓	✓	✓
Side marker	F239	12V 5W	✓	✓	✓	✓
Reversing light	L382	12V 21W	✓	✓	✓	✓
Rear indicator light	L382	12V 21W	✓	✓	✓	✓
Brake light	L382	12V 21W	✓			
Brake / tail light	L380	12V 21W/5W		✓	✓	✓
Fog light	L382	12V 21W		✓	✓	✓
Fog / tail light	L380	12V 21W/5W	✓			
Number plate light	F239	12V 5W	✓	✓	✓	✓
High level brake light	Capless	12V 2.3W		✓	✓	✓
Hitch cover light	F239	12V 5W			✓	✓
INTERIOR/OTHER						
Awning	L245	12V 10W	✓	✓		
Awning	P21W	12V 20W			✓	✓
Eyeball reading	L245	12V 10W	✓	✓		
Adjustable reading light	Halogen Capsule	G4 12V 5W			✓	✓
Downlighters	Halogen Capsule	G4 12V 5W			✓	✓
Round ceiling lights	Halogen Capsule	G4 12V 20W	✓	✓		
Round ceiling lights	Halogen Capsule	G4 12V 10W			✓ (2)	✓ (2)
Round ceiling lights(small)	Halogen Capsule	G4 12V 10W	✓	✓		
Kitchen strip light	Fluorescent 300mm	12V 8W	✓	✓		
Vanity strip light	Fluorescent 300mm	12V 8W	✓	✓		
Mains reading	Small Screw Candle	240V 40W	✓	✓	✓	✓

Note: Not all lights and bulbs feature on all models within a range

NOTIFICATION OF CHANGE OF OWNERSHIP

If you sell your caravan, please notify the change of ownership by completing this page, detaching it and sending it to:
Swift Group Ltd., Dunswell Road, Cottingham, East Yorkshire, HU16 4JX.

DETAILS OF CARAVAN:	Model:	_____
	Chassis No:	_____
CURRENT OWNER:	Name:	_____
	Address:	_____

NEW OWNER:	Name:	_____
	Address:	_____

Please note that the benefit of any unexpired warranty cannot be transferred to the new owner until the change of ownership details above have been received.



The Hallmark of Excellence

Sterling Caravans, Dunswell Road, Cottingham, East Yorkshire HU16 4JX.

Tel: 01482 875740 Fax: 01482 840082

e-mail: enquiry@supercare.co.uk website: www.sterlingcaravans.co.uk

A MEMBER OF THE SWIFT GROUP

Issued September 2001

1043692