

Swift Owner's Handbook



Wherever you want to go, we're right behind you.

Congratulations. You couldn't have made a better choice than a Swift caravan.

And when it comes to buying a new caravan or car, Black Horse are the finance experts.

With a range of finance options to suit you, and a wealth of experience, you can relax in the knowledge that Swift and Black Horse are right behind you wherever you want to go.



blackhorse
CARAVAN FINANCE

Credit is available to persons aged 18 or over. Guarantors may be required. Written quotations available on request from:
Black Horse Caravan Finance, 24 - 26 Newport Road, Cardiff CF24 0SR Tel: 029 2029 6863

INTRODUCTION

DEAR OWNER,

THANK YOU FOR DECIDING TO BUY ONE OF OUR NEW CARAVANS. WE ARE SURE YOU WILL ENJOY MANY HAPPY HOURS IN IT AND WE HOPE THE INFORMATION AND HINTS IN THIS HANDBOOK WILL HEIGHTEN YOUR ENJOYMENT.

THE HANDBOOK HAS BEEN DESIGNED TO GIVE YOU A GENERAL GUIDE TO THE CARE, USE AND MAINTENANCE OF YOUR CARAVAN. WHETHER YOU ARE A NEW OR AN EXPERIENCED CARAVANNER THE HINTS WILL HELP TO PROTECT YOUR INVESTMENT.

THE INFORMATION CONTAINED WILL ANSWER MOST OF YOUR QUERIES, BUT IF THERE ARE ANY ASPECTS WHICH ARE NOT COVERED PLEASE CONSULT YOUR APPOINTED DEALER.

HAPPY CARAVANNING!

CONTENTS

The Towing Code



Safety and Security



Services



Electrical Equipment



Fitted Equipment



Maintenance



General Data





THE TOWING CODE

The Caravan Towing Code	2
Scope of the Code	2
Caravan Terms	2
Weights	2
Towing Vehicle Terms	3
Weights	3
Measurement of Noseweight	4
Type of Driving Licence Held	4
Glossary & Checklist	4
Preparing for the Road	7
Checklist	7
Loading & Distribution	7
Stability	8
Pre-tow Checklist	10
Pulling Off	13
Reversing	13
Speed Limits	13
Caravan Handling	13
Motorway Driving	13
Changing a Wheel	14
Jacking Points	14
Stopping on a Hill	14
Arrival on Site	15



The Towing Code

THE CARAVAN TOWING CODE

This Code of Practice contains recommendations jointly reviewed and agreed by the following organisations:

The National Caravan Council
The Caravan Club
The Camping and Caravanning Club
The Caravan Writers Guild
The Department of Transport

Scope of the Code

The Code applies to all trailer caravans of maximum laden weight not exceeding 3500 kg (7,700 lbs), overall width not exceeding 2.3m (7ft 6in approximately) and overall length not exceeding 7m (23ft approximately), excluding the drawbar and coupling.

This is legally the maximum size of trailer that can be towed by a motor vehicle with a maximum gross weight of less than 3500 kg.

CARAVAN TERMS

Mass in Running Order:

The mass of the caravan as stated by the caravan manufacturer, as new with standard fixtures and fittings.

Note: Because of differences in the weight of materials supplied for the construction of caravans, a tolerance of +3% of the weight has been allowed in the Mass in Running Order weight.

User Payload:

The maximum allowable weight to be put into the caravan whilst it is being towed. This is made up of 3 sections:

Personal effects, optional equipment and essential habitation equipment.

The user payload is the difference between the Maximum Technically Permissible Laden Mass and the Mass in Running Order.

Essential Habitation Equipment:

Those items and fluids required for safe and proper functioning of the equipment for habitation as defined by manufacturer of the caravan.

Personal Effects:

Those items which a user can choose to carry in a caravan and which are not included as Essential Habitation Equipment or Optional equipment.

Optional Equipment:

Items made available by the manufacturer over and above the standard specification of the caravan.

Maximum Technically Permissible Laden Mass:

The maximum weight for which the caravan is designed for normal use when being towed on a road, laden. This should not be exceeded. This mass takes into account specific operating conditions including factors such as the strength of materials,

loading capacity of tyres etc.

Nose weight:

That part of the static mass of the caravan supported by the towing device on the rear of the towing vehicle.

Notes:

- (i) When measuring the noseweight it is important that the caravan is fully loaded. Do not place extra items indiscriminately into the caravan after this adjustment has been made.
- (ii) The caravan is intended to be towed slightly nose heavy. The nose weight can be adjusted by distribution of the load within the caravan. The nose weight should be approximately 7% of the actual laden weight (but not greater than the hitch capacity) and at the same time suit the towing vehicle. See section on Measurement of Nose Weight.
- (iii) It is not recommended that you tow with just a battery, spare wheel and gas bottles as this may exceed the the permitted nose weight. Additional payload must be placed behind the axle to compensate for this or consider repositioning the wheel to a underfloor carrier.

TOWING VEHICLE TERMS

Kerb weight (Mass of Vehicle in Running Order):

The weight of the towing vehicle as defined by the vehicle manufacturer. This is normally with a full tank of fuel, with an adequate supply of liquids incidental to the vehicles propulsion, without driver or passengers, without any load except loose tools and equipment with which the vehicle is normally provided and without any towing bracket.

Caravan to Towing Vehicle Weight Ratio:

The towing vehicle to caravan weight ratio can be determined by calculation and is equal to:

$$\frac{\text{actual laden weight of caravan}}{\text{Kerb weight of towing vehicle}} \times 100\%$$

THE **LAW** REQUIRES THAT CARAVANS & THEIR TOWING VEHICLES & THE LOADS THEY CARRY MUST BE IN SUCH A CONDITION THAT NO DANGER OR NUISANCE IS CAUSED.

(Regulation 100 of the Road and Vehicles [Construction and Use] Regulations 1986).

Power to weight ratio:

No hard and fast rules can be stated but, here is a general guide.

- (a) Conventional petrol engines with a capacity up to approximately 1500 cc should be adequate for towing a

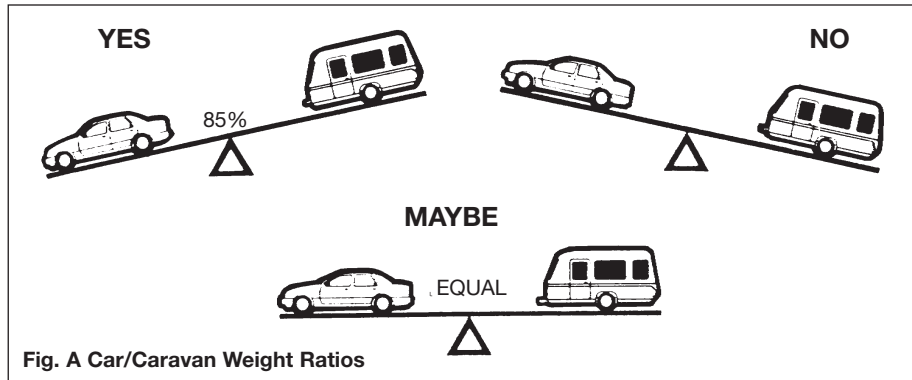

Fig. A Car/Caravan Weight Ratios

caravan weighing around 85% of the kerb weight of the towing vehicle.

- (b) Above 1500 cc such engines should manage a caravan weighing up to 100% of the kerb weight of the towing vehicle and still give adequate performance.

Note: The towing vehicle manufacturer's limit is, in some cases, less than the kerb weight.

Vehicles with automatic transmission may need an oil cooler fitting or the SAE rating of the gearbox oil increasing when towing. The advice of the vehicle manufacturer should be sought.

Mass in Running Order:

Caravanners can use a public weighbridge to establish the mass in running order.

Note: Weighbridges have varying weight tolerance levels.

Maximum Permissible Towing Mass:

The weight defined by the vehicle manufacturer as being the maximum that the vehicle is designed to tow.

Train Weight (Combination Weight):

The maximum combined weight of the towing vehicle and trailer combination as specified by the towing vehicle manufacturer.



The Towing Code

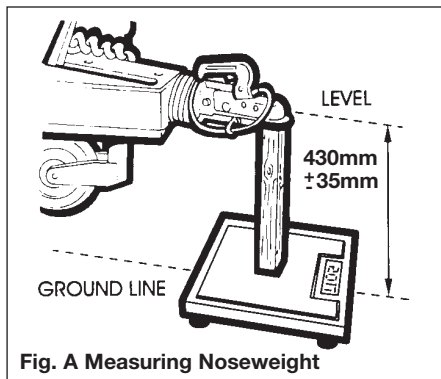

MEASUREMENT OF NOSEWEIGHT

Noseweight may be measured using a proprietary brand of noseweight indicator.

Such equipment is obtainable at your Caravan Dealer.

Note: These indicators have a varying tolerance level.

Another simple method is to use bathroom scales under the coupling head with a piece of wood, fitted between the coupling head and the scales, of such length that the caravan floor is horizontal with the jockey wheel raised clear of the ground. (Fig. A)

Noseweight can be adjusted simply by distribution of weights in the caravan. Always

lower jockey wheel before entering the caravan and then raise before measuring again. (See **Loading**).

Note: The height of the towball on the towing vehicle, when laden, is also critical.

TYPE OF DRIVING LICENCE HELD

In order to be able to tow a caravan a driver must hold a Category B licence. Those car drivers who passed their tests prior to 1 January 1997 would have automatically obtained Category B+E. However, anyone who passed their test after 1 January 1997 will need to take a further test in order to obtain a Category B+E if they wish to tow a car and caravan combination whose train weight exceeds 3,500kg, or up to 4,250 if the caravan is less than 750kg or if the caravan's Maximum Technically Permissible Laden Mass exceeds the unladen weight of the car.

Note: The unladen weight of a car is normally less than the kerbside weight.

GLOSSARY & CHECKLIST

Awnings - Can consist of just a simple top sheet but may extend to a five sided frame tent attached to the side of the caravan.

Fire blanket - approved to BS 6575 is ideal for dealing with 'fat pan' fires.

Fire extinguisher - It is strongly recommended that a fire extinguisher is carried in the caravan. (For suitable types see **Safety and Security**).

Gas bottles - Bottled L.P. gas is the most convenient portable source of fuel. Two bottles are required for a constant supply. An initial deposit is payable on each cylinder. We recommend the use of 6kg Propane or 7kg Butane bottles. One position for use and one for storage only. (For detailed information see **Services - Gas**).

Jack - A suitable jack is essential (screw, scissor, side mounted or air jack type). Many car jacks are unsuitable.

Levellers - Levellers help level the caravan from side to side before unhitching. Proprietary products can be purchased from your caravan dealer and need to be positioned as indicated by a spirit level.

Spare Wheel - It is always advisable to carry a spare wheel for your caravan.

Spirit Level - A spirit level is extremely useful when siting the caravan.

Stabiliser - Stabilisers help to dampen the side to side movement of the caravan. One end fits to the car's towing bracket and the other end to the caravan. (See **Stability**)

Torque Wrench - A torque wrench is the only way that the exact recommended torque can be achieved for wheel nuts and bolts. (See **Preparing for the Road**).

Towing Bracket - Car manufacturers recommend that their own bracket is fitted at a specialist dealer, to ensure that it is fixed to the correct mounting points. Never use cheap alternatives, obtain one manufactured by a reputable company complying with the relevant standards.

Wooden Blocks - Wooden blocks typically 25cm. square and 2cm. thick are ideal for placing under corner steadies and jockey wheel when the ground is uneven or soft.

Water Containers - Two containers are required, one to carry fresh water to the caravan and one for waste water, which needs to be disposed of properly. Several types are available including jerry cans, folding cans and wheeled containers.

12N & 12S Sockets - Two sockets designated 12N and 12S are fitted to your car to accept corresponding plugs from the caravan. These are necessary to energise the road lights and caravan auxiliary circuits respectively.

12 Volt Battery - A deep cycling, heavy duty leisure type battery should be purchased to provide back-up power for lights and other electrical appliances. (See **Battery**).

WARNING: Your caravan dealer should be consulted if additional equipment is to be fitted as strong points may or may not be provided in the design.

Note: Fitting additional equipment will reduce the caravan allowable payload.



The Towing Code

Useful memory aid for other items.

Car	Gas regulator	Domestic	Floor cloth	Tea strainer
Distilled water	Jack	Adhesive tape	Fly spray	Tea towels
External mirrors	Levelling boards	Air freshener	Food	Table cloths
Fan belt	Mallet	Aluminium foil	Food mixer	Table mats
Fire extinguisher	Site/caravan mains lead	Ashtrays	Frying pan	Television
Jack	Spare bulbs	Bin liners	Glasses	Tin opener
Jump leads	(Mandatory in E.C.)	Binoculars	Grill pan	Tissues
Petrol can	Spare 12v fuses	Bottle opener	Jugs	Toilet paper
Socket set	Spare gas hose	Breadboard	Kettle	Torch
Spare bulbs	Spare wheel	Breadbin	Kitchen roll	Towels
Spare keys	Spirit level	Brush and dustpan	Kitchen tools	Toys & Games
Spare wheel	Toilet fluid	Butter dish	Litter bin	Vacuum cleaner
Tool kit	Waste water container	Camera and films	Matches	Washing up bowl
Towball cover	Wheel brace	Carving knife	Measuring jug	
Tow rope		Cassette recorder	Milk jug	Documents
Tyre pressure gauge	Personal	Chairs	Mixing bowl	Bail Bonds
Warning triangle	After sun cream	Clock	Needles and thread	(some Euro countries)
Tyre Pump	First Aid Kit	Clothes brush	Oven gloves	Bank and credit cards
	Flannels	Clothes line	Pegs	Caravan Certificate
Caravan	Hairbrush and comb	Coat hangers	Piezo Gas lighter	Cheque book
Awning pegs and poles	Make up. etc.	Coffee percolator	Potato peeler	CRIS document
Awning ground sheet	Raincoats	Coolbox	Pressure cooker	Driving licence
Battery 12 volt charger	Toothbrush	Colander	Radio	Green Card Insurance
Bucket	Toothpaste	Crockery	Rubbish bin	(some Euro countries)
Corner steady brace	Scissors	Cruet	Salad shaker	Maps and guides
Corner steady pads	Shampoo	Corkscrew	Saucepans	Money
Coupling lock	Shaving kit	Cutlery	Scissors	MOT Certificate
Door mat	Shoe cleaning kit	Dish cloth and brush	Sieve	Vehicle Registration
Fire blanket	Soap	Dusters and polish	Sugar bowl	Documents
Fire extinguisher	Sun tan oil	Disposable cloths	Shopping bags	
Fresh water container	Wellington boots	Egg cups	Sleeping bags	
Gas cylinder		Electrical extension lead	Tea pot	

PREPARING FOR THE ROAD

PRE-LOAD CHECKLIST

Caution: Never enter the caravan without first lowering the four corner steadies with the brace provided.

BEFORE LOADING CHECK:

- loose articles are stowed securely. Do not stow tins, bottles or heavy items in overhead lockers prior to towing.
- all lockers and cupboard doors are closed and secured.
- all bunks are secure.
- all rooflights are closed and secured.
- main table is stored in its transit position.
- fridge is on 12v operation and door lock is set.
- all windows are fully closed and latched. Never tow with windows on night setting. Leave all curtains and blinds open to aid rear visibility.
- gas cylinders are correctly positioned, secured and turned off.
- battery is secure and mains connecting cable is disconnected and stowed.
- 12v distribution panel selector switch is set to centre position.

WARNING: Isolate all gas appliances before setting off.

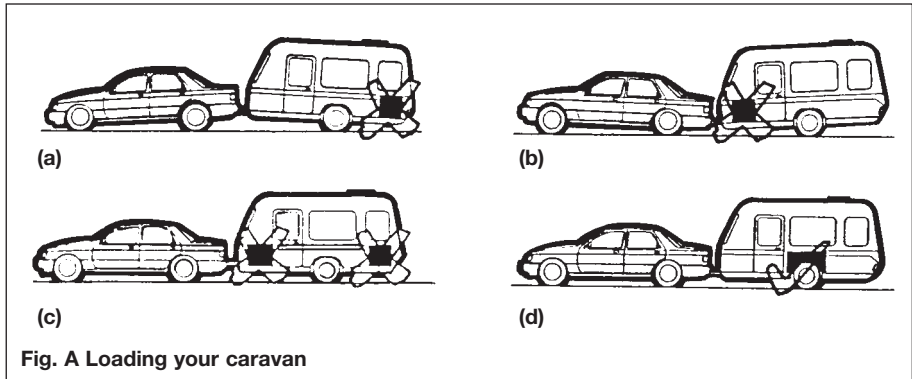

WARNING: Do not travel with televisions or microwaves in overhead lockers unless the appliance was supplied fitted to your caravan by the manufacturer.

LOADING AND DISTRIBUTION OF WEIGHT IN THE CARAVAN

Do not exceed recommended maximum loading for your caravan.

1. Load heavy items low down near the floor and mainly over or just in front of the axle(s) (Fig. A).
2. Load evenly right to left so that each caravan wheel carries approximately the same weight.
3. Do not load items at the extreme front or

rear since this can lead to instability due to the 'pendulum effect'.

4. Load remainder to give a suitable noseweight at the towing coupling.

Check noseweight.

Note: Do not overload car boot.

Note: Please take care to ensure that you have allowed for the masses of all items you intend to carry in the caravan

The Towing Code

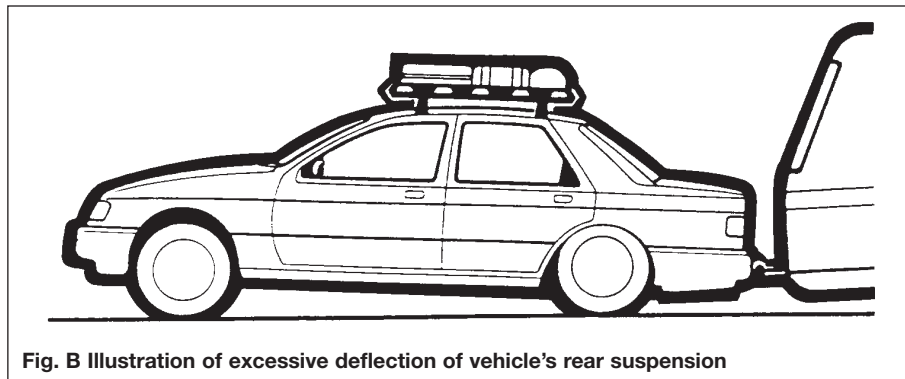
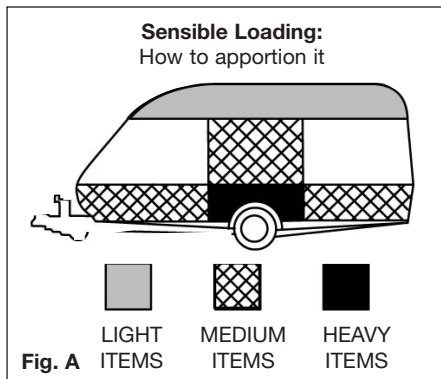

Towing vehicle's rear suspension

It is important that the towing vehicle's rear suspension is not deflected excessively by the noseweight on the tow ball. If it is excessive the steering and stability will be affected. (Fig. B)

The greater the towing vehicle's tail overhang (the distance between the rear axle and the tow ball) the greater the effect the noseweight will have on the towing vehicle's rear suspension.

After trying out the caravan it may be found that stiffening of the rear suspension is necessary - but note that this may give the towing vehicle a firmer ride when not towing.

There are a number of suspension aids available and advice should be sought on which to use and how to fit. It is important to ensure that the caravan is towed either level or slightly nose down.

If you have any doubts about the suitability of your towbar for towing a twin axle caravan consult the towing bracket manufacturer.

DO NOT exceed the:

- Gross Vehicle Mass (G.V.M. on car plate).
- Maximum Technically Permissible Laden Mass (M.T.P.L.M.).
- Gross Vehicle Combination Mass (Train Weight) (G.V.C.M. on car plate).
- Maximum Permissible Towing Mass.

STABILITY

All our models are of a well balanced design and should be exceptionally good towers. The most common causes of poor stability include:

- (a) Worn springs or loose spring fixings on the towing vehicle.
- (b) Towing vehicle springs too soft.
- (c) Insufficient noseweight.
- (d) Nose of caravan is towing too high.

Galvanised steel chassis

Drilling of the galvanised steel chassis will invalidate the warranty. If fixing a towing aid, in the first instance consult your dealer as regards suitability.

The Towing Code

Never drill the coupling head to aid the fitting of a stabiliser.

Note: Some stabilisers may require the towing vehicle to be fitted with an ungreased or swan neck tow ball. Please refer to manufacturer's fitting instructions.

Suitable towing vehicles

The caravan is manufactured for towing behind normal road cars and is not suitable for towing behind commercial vehicles. It is strongly recommended that whenever a caravan is to be towed over rough terrain, e.g. a farmer's field or track, great care should be taken to ensure that no undue stress is placed upon the caravan via the hitch mounting, i.e. reduce speed. If in doubt, please consult the chassis manufacturer and the towing vehicle manufacturer who will advise. Touring caravans based on standard Al-Ko chassis can be towed by four wheel drive off road leisure vehicles providing the unit is used to tow in a like manner to a conventional road-going car and driven in the same considered manner.

Snaking

This is a term used to denote an unstable car and caravan combination where the caravan 'weaves' from side to side often causing a similar swaying movement in the car itself.

Causes:

i) Unsuitable or unbalanced outfit.

- ii) Incorrect loading or weight distribution.
- iii) Excessive speed especially downhill.
- iv) Side winds.
- v) Overtaking.
- vi) Being overtaken by a large fast moving vehicle.
- vii) Erratic driving.
- viii) Insufficient tyre pressures.
- ix) Mixing radial and cross ply tyres.

Cures:

Cases of persistent snaking can be alleviated by the use of a stabiliser, about which your dealer will advise you.

On the road

If you do find your outfit snaking, try to keep the steering wheel in a central position as far as possible, decelerate and avoid braking if possible.

OTHER IMPORTANT TOWING CONSIDERATIONS THAT COULD AFFECT STABILITY

Types of tyres fitted

The tyres fitted by the manufacturer are suitable for towing at sustained speeds of up to 81 mph (130 kph).

Radial and cross ply tyres should never be mixed. It is dangerous and can cause snaking.

Periodically tyres should be rotated to equalise wear in the same manner as car tyres.

Do not mix four ply/six ply/eight ply tyres on the same axle.

Tyre tread

The law requires that tyres and pressures must be suitable for the use to which they are being put. The minimum tread depth of both car and caravan tyres must be 1.6mm throughout a continuous band comprising the central three quarters of the breadth of tread and around the entire circumference of the tyre.

Tyre pressures

Towing vehicle's tyres must be at the pressures recommended for towing or heavy loading as stated in handbook not on tyre wall. Towing stability may otherwise be affected. The pressures can be found in the towing vehicle handbook. The caravan tyre pressures should be as recommended in the specification details in your handbook.

Note: Although the caravan may be fitted with the same type of tyre as the towing vehicle, the pressures specified are different. All charts show values for cars and are therefore not applicable for caravans. Pressures displayed on tyre walls apply ONLY in North America and Canada.



The Towing Code

Wheels

Caravan wheel nuts should be tightened to a torque of 88Nm (65lb/ft) on steel wheels or 115Nm (85lb/ft) on alloy wheels and should be checked with the use of a torque wrench regularly. Only use a spare wheel and tyre recommended by the manufacturer.

Wheel Rims

The majority of caravans manufactured since 1993 have been fitted with steel wheel rims which are the wider 5J size incorporating a double safety hump rim which conforms to European standards of safety. The alternative to steel wheel rims are alloy wheel rims.

If you are in any doubt, have your wheels checked by a competent tyre supplier.

Hitch head load capacity

The maximum vertical static load which can be put upon the hitch head when connected is 100kg. Please refer to the technical data in your handbook.

(But see also vehicle manufacturer's weight limits on towball loading.)

PRE-TOW CHECKLIST AND HITCH-UP

Check Gas Locker, Battery Locker (if fitted) and Cassette Toilet (if fitted) door/s are secure.

Check wheelnuts, tyre pressures and tyre conditions.

Fully raise all four corner steadies. (Fig. A).

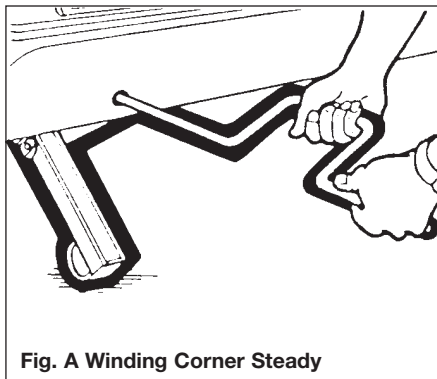

Fig. A Winding Corner Steady

Pick up any levelling pads or levelling boards.

Check rooflights/vents are securely closed.

Switch off gas supply and change over to electricity if required.

Lock the caravan exterior door.

An assistant can help in the hitching operation by standing on the left hand side of the drawbar (facing rear of car) and extending an arm horizontally to indicate position of the coupling. When reversing aim the towball of the car directly at the caravan drawbar. Remove towball cover and keep in car.

Adjust the jockey wheel to ensure the cup is high enough to slide over the towball.

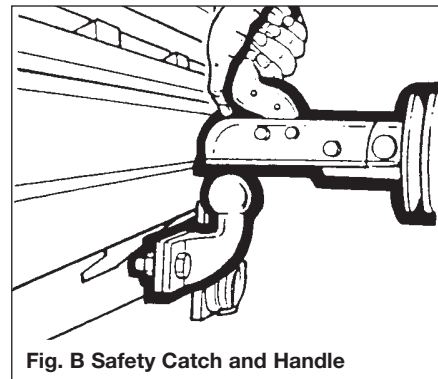

Fig. B Safety Catch and Handle

Release caravan handbrake.

Position cup over greased towball, release safety catch and lift handle (Fig. B). The hitch head is fitted with a visual indicator to show whether or not it is properly connected to the towball. A green band will show immediately below the red indicator button on the hitch head when a proper connection has been made. (See Fig. D, Page 11)

WARNING: Serious damage will occur unless the locking button is depressed first and the handle lifted forward before the caravan is lowered manually. This prevents the noseweight being transmitted through the locking button.

The Towing Code

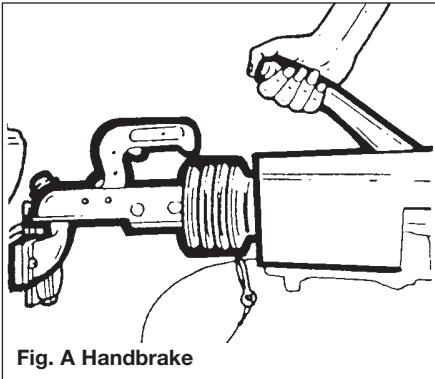

WARNING: If the green band is showing when the hitch head is not connected to the towball there is a fault - contact your Dealer.

Adjust jockey wheel to lower cup on to the ball. A click indicates it is fully engaged. Ensure locking button has returned to its free position.

Secure caravan handbrake. (Fig. A)

Connect breakaway cable (emergency braking device) in the form of a noose to suitable anchorage point on towbar. DO NOT attach to towball.

Ensure that the jockey wheel is fully wound up and properly located in the slots, then release the clamp handle, lift the whole unit

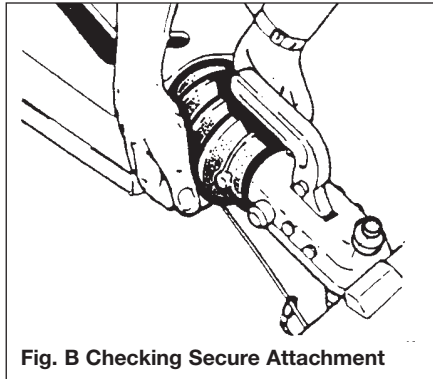

as high as possible and retighten the clamp handle.

Note: Ensure jockey wheel locates in recess provided.

Take hold of the caravan under the rubber gaiter behind the coupling and lift to ascertain whether the caravan is properly attached. (Figs. B & D.)

Lock hitch if possible (see Safety and Security, page 20).

Connect 7 pin plugs to car sockets ensuring there is enough loose cable for cornering. (Fig. C)

Check all car and caravan roadlights are working. Check round the caravan for anything left behind.

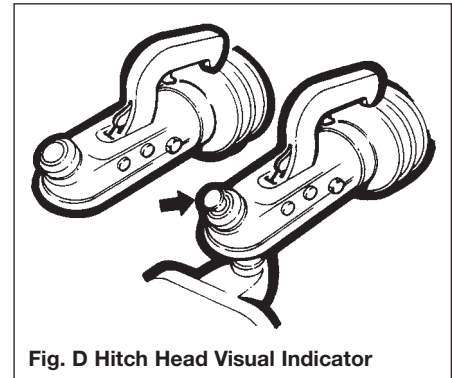
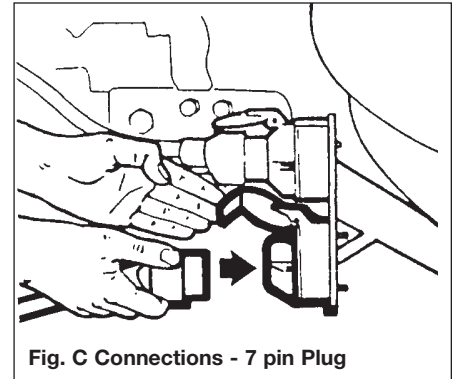

Release caravan handbrake, adjust all mirrors from driving seat and proceed.

The Towing Code

12N AND 12S VIEWED FROM REAR OF PLUG

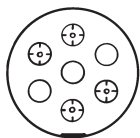

12N (BLACK)

TERMINAL	COLOUR	12N PLUG
1	YELLOW	L/H INDICATOR
2	BLUE	REAR FOG LAMP
3	WHITE	COMMON RETURN (1-7)
4	GREEN	R/H INDICATOR
5	BROWN	R/H SIDE TAIL & No PLATE LIGHT
6	RED	STOP LAMP
7	BLACK	L/H SIDE TAIL & No PLATE LIGHT

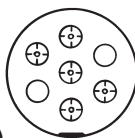

12S (GREY)

TERMINAL	COLOUR	12S PLUG
1	YELLOW	REVERSING LIGHT
2	BLUE	NO ALLOCATION
3	WHITE	NEGATIVE PIN 4
4	GREEN	CONTINUOUS POWER SUPPLY
5	BROWN	NO ALLOCATION
6	RED	FRIDGE
7	BLACK	RETURN FOR FRIDGE

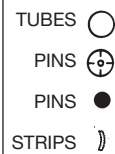

ROAD LIGHTING

For your information the wiring diagram of the 12N and 12S connectors is shown opposite. These should be checked regularly and if in any doubt a qualified electrician consulted.

Some European cars may be equipped with Volta, Jeager, West or multi-con sockets, an adaptor or replacement sockets may be required. If so consult your dealer or qualified electrician.

The wiring allocations were changed in 1998 and it is important that you check the car to caravan connections are compatible prior to coupling up to the car.

VOLTA/JEAGER & MULTICON FEDER 13 PIN PLUGS (viewed from rear)

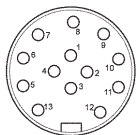

VOLTA/JEAGER

PIN NO	COLOUR	DESCRIPTION
1	YELLOW	LEFT FLASHER
2	BLUE	FOG HAZARD LIGHT
3	WHITE	EARTH FOR 1-8
4	GREEN	RIGHT FLASHER
5	BROWN	RIGHT TAIL LIGHT
6	RED	STOP LIGHTS
7	BLACK	LEFT TAIL LIGHT
8	ORANGE	REVERSE LIGHTS
9	BROWN/BLUE	CAR +
10	BROWN/RED	FRIDGE
11	WHITE/BLACK	EARTH FOR 10
12	NOT YET ALLOCATED	
13	WHITE/GREEN	EARTH FOR 9

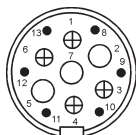

WEST

PIN NO	COLOUR	DESCRIPTION
1	YELLOW	LEFT FLASHER
2	BLUE	FOG HAZARD LIGHT
3	WHITE	EARTH FOR 1-8
4	GREEN	RIGHT FLASHER
5	BROWN	RIGHT TAIL LIGHT
6	RED	STOP LIGHTS
7	BLACK	LEFT TAIL LIGHT
8	ORANGE	REVERSE LIGHTS
9	BROWN/BLUE	CAR +
10	BROWN/RED	FRIDGE
11	WHITE/BLACK	EARTH FOR 10
12	NOT YET ALLOCATED	
13	WHITE/GREEN	EARTH FOR 9

MULTICON FEDER 13K

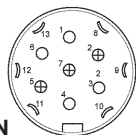

WARNING: Always disconnect the electrical connector between the towing vehicle and the caravan before connecting a low voltage supply to the caravan (mains) and before charging the battery (EN 1648-1).

PASSENGERS

Passengers are forbidden to ride in a caravan with the exception of authorised test personnel.

BRAKES/BREAKAWAY CABLE

A breakaway cable is required for caravans and the device must be such that the caravan stops automatically if the coupling breaks (Regulation 15 of the Road Vehicles [Construction and Use] Regulations 1986).

Always ensure that the breakaway cable is connected to the towing vehicle, not to the towball.

MIRRORS

The driver of the towing vehicle must have an adequate view of the rear.

If there is no rear view through the caravan it is essential that additional exterior towing mirrors are fitted. This is mandatory in some European countries and drivers can face instant fines if extension mirrors are not fitted.

Caution: Any rear view mirror must not project more than 200 mm outside:

- the width of the caravan when being towed.
- the width of the towing vehicle when driven solo.

Note: Any rear view mirror fitted shall be 'e' marked and cover the field of view as stipulated by type approval requirements (Regulation 33 of the Road Vehicles [Construction and Use] Regulation 1986).

PULLING OFF

Let the clutch in smoothly.

Allow more engine speed to produce the power to move the additional weight of the caravan.

Reduce wear and tear on clutch and transmission by taking extra care.

Change gears smoothly.

Try not to jerk the clutch.

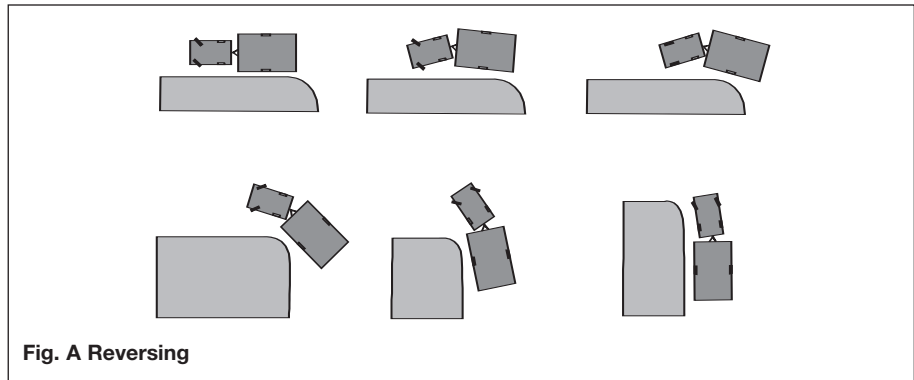

REVERSING

Proficiency at reversing can only be achieved with practice and should be first attempted in a large open area (Fig. A).

SPEED LIMITS

Normal road towing: 50mph

Motorways (including dual carriageways): 60mph

CARAVAN HANDLING

Allow for caravan being wider than car.

Do not bump kerb with caravan wheels.

When passing other vehicles allow more than the normal clearance for driving solo.

Allow longer to get up speed to pass.

Allow for the outfit being twice its normal length.

Do not suddenly swing out.

Carry out all manoeuvres as smoothly as possible.

Use nearside wing mirror to check caravan has cleared when overtaking.

IMPORTANT POINTS ESPECIALLY FOR MOTORWAY DRIVING

- Caravans may not be towed in the outside lane of a three or four lane motorway. (Reg. 12(2) of the Motorway Traffic [England and Wales] Regulations 1982).



The Towing Code

2. Reduce Speed:
 - i) In high or cross winds.
 - ii) Downhill.
 - iii) In poor visibility.
3. High sided vehicles cause air buffeting so extra care must be taken when passing or being passed. As much space as possible should be given.

CHANGING A WHEEL

1. Leave caravan hitched to towing vehicle and ensure handbrake is applied.
2. Lower corner steadies (as safety measure) on the side that the wheel is being changed to stabilise the caravan.
3. Use wheel brace to slacken off wheel nuts on the wheel to be changed.
4. Position jack under the axle at the appropriate jacking point (see fig. B)
5. Jack up the caravan until the wheel for removal is just off the ground.
6. Remove the wheel nuts, wheel trims and remove the wheel.
7. Fit spare wheel and reverse the above procedure.
8. Tighten all four nuts, according to Fig. A, to 88Nm (65lb/ft) for steel wheels or 115Nm (85lb/ft) for alloy wheels using a torque wrench or have checked as soon as possible.

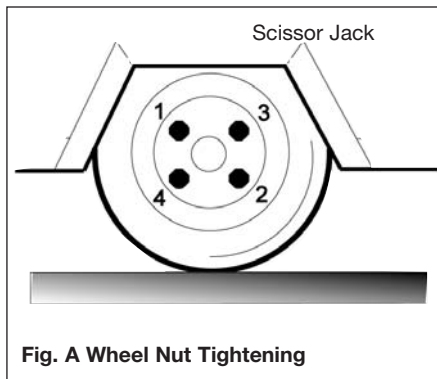

Fig. A Wheel Nut Tightening

IMPORTANT

When a wheel has been removed and replaced the torque of the wheel nuts should be re-checked after approximately 15 miles of running. (See 8 above).

JACKING POINTS

WARNING: Only jack up your caravan when it is coupled up to the car with its handbrake applied and in 1st gear (engine off).

Ensure that the jack is located in the correct position, i.e. on the jacking bracket on the chassis for the Al-Ko side mounted jack (Fig.B). Alternatively the reinforced axle mounting plate can be used as an alternative

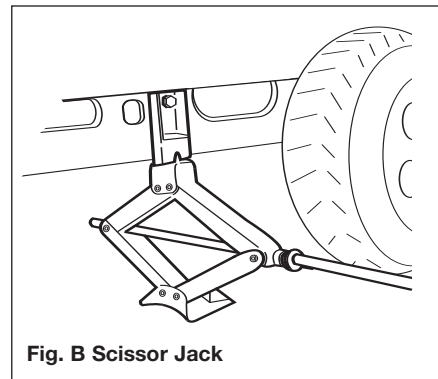

Fig. B Scissor Jack

but the chassis member itself **MUST NEVER** be used as a jacking point.

All caravans are provided with the facility to fit Al-Ko side jacking points and although a scissor, trolley or bottle jack may be used, it is recommended that the side mounted Al-Ko Jacking System should be used.

STOPPING ON A HILL

Pulling off again can sometimes present a problem. The easy solution is

- (i) Carry a good sized wedge shaped piece of wood with a rope or light chain attached.
- (ii) Attach the other end of the rope to the nearside rear grab handle.

The Towing Code

- (iii) Place the wood behind the nearside caravan wheel.
- (iv) Carefully reverse the car slightly back down the hill, the caravan will stop against the wedge and turn.
- (v) Drive forward since this attempt to move up the hill will now not involve pulling the full weight of the caravan until the car has gained some traction.

ARRIVAL ON SITE

Note: Check and observe site regulations.

1. Selecting a pitch

Do not pitch in such a position that your outfit will obstruct others coming in.

Try to choose an area which is dry, reasonably level and preferably with a hard base.

If you have no alternative but to pitch on a slope ensure that, for when you leave, you are facing down the slope.

It is good practice to chock the wheels of the caravan when parked on a slope even though the caravan brakes are applied.

2. Levelling the caravan

Levelling must be carried out in both directions in order for the refrigerator and other equipment to function correctly. This should be done before unhitching the caravan. Levelling boards (Fig. C) can be used to raise one side of the caravan by driving or reversing the caravan onto the boards. Apply the handbrake and chock the wheels.

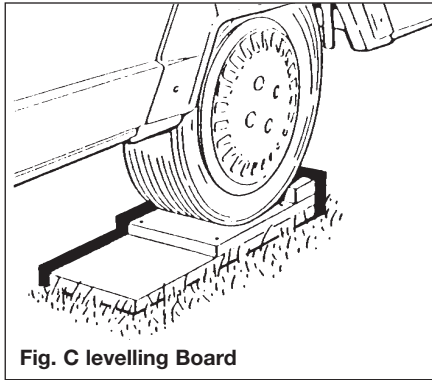

Fig. C levelling Board

The positioning of the jockey wheel can be used to help level the caravan.

Lower the corner steadies until they are in firm contact with the ground.

DO NOT use the steadies as a jack they are only a means of stabilising the caravan.

Levelling pads or boards should be used under the steadies where the ground is soft or uneven.

In extreme cases where it is necessary to raise a wheel off the ground for levelling purposes, further adequate support should be applied so that the steadies do not take

any undue strain.

Exterior Door

To prevent distortion of the body, the caravan must be always correctly sited and levelled. Failure to site the caravan correctly may prevent the exterior door from closing properly.

3. Unhitching

Apply the caravan handbrake.

Lower the jockey wheel to the ground.

Disconnect the breakaway cable and road lighting plugs.

Operate the handle by depressing the locking button on the lever mechanism and lift the handle upwards and forwards, at the same time winding down the jockey wheel, to assist in lifting the caravan clear of the towing vehicle.

When this operation is complete, replace towball cover.

Park your vehicle alongside the caravan on the offside.





SAFETY AND SECURITY

Fire	18
Notice	18
In Case of Fire	18
Dicon 300AP Smoke Alarm.....	18
Smoke Alarm.....	18
Fire Extinguishers.....	19
Children	19
Ventilation	19
Security	20
Caravan Theft	20
Chassis Number.....	20
Additional Security	20
Security Chips.....	20



Safety & Security

FIRE

Important: Your attention is drawn to the notice affixed inside the caravan advising on fire precaution, ventilation and what to do in case of fire.

IN CASE OF FIRE

1. Get everyone out of the caravan as quickly as possible using whichever exit is the quickest, including windows. Do not stop to collect any personal items.
2. Raise the Alarm. Call the Fire Brigade.
3. Turn off the gas supply valve if it is safe to do so.
4. Turn off the electricity supply at supply point.

DICON 300AP SMOKE ALARM

This smoke alarm is approved for use in caravans and mobile homes. (Fig. A)

The National Caravan Council requires that all new or used caravans sold by its members be fitted with a smoke alarm featuring an alarm silence facility.

FEATURES

- Battery operated. No need for mains power wiring.
- Operating Light (LED)
Flashes approximately every 45 seconds confirming unit is powered.

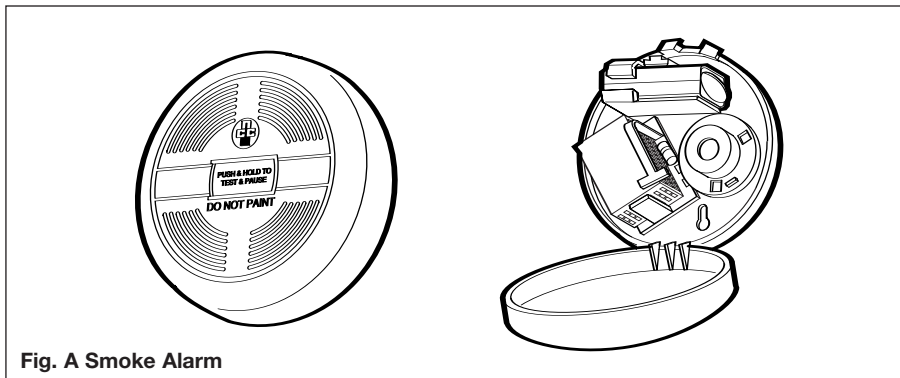

Fig. A Smoke Alarm

- Low Battery Warning
Unit “beeps” approximately every 45 seconds for up to 30 days when the battery needs replacing.
- Sensitivity Test Button
Test sensitivity, circuitry, battery and horn.
- Loud 85 Decibel Piezo Electric Alarm
Automatically resets when hazardous condition has passed.
- Precise Sensitivity
- High Quality Solid State Components

CONNECTING THE BATTERY

Your alarm requires one 9 volt battery to power the smoke detector portion of the unit. Under normal use the battery powering

the smoke detector should last approximately one year.

WARNING: Ensure that batteries are correctly installed. Positive terminal to positive contact (marked +), negative terminal to negative contact. Reversing a battery in its compartment will immediately drain the battery and could damage the smoke alarm.

HOW TO TEST

Press test button until alarm sounds, then release. Repeat test weekly.

Note: Always test smoke alarm operation after vehicle has been in storage, before each trip and at least once per week during use.

WARNING: The electronic test button provides a full test of the unit's functionality. DO NOT try to test the alarm with a naked flame, as this may present a potential fire hazard.

FALSE ALARMS

Abnormal air conditions may cause the highly sensitive smoke alarm to give a "false" alarm. **DO NOT DISCONNECT THE BATTERIES.** If no fire is apparent, ventilate the caravan and/or blow fresh air into the unit until the alarm stops. Once cleared the smoke alarm will automatically reset.

MAINTENANCE

Dust can lead to excess sensitivity therefore it is recommended that the unit be vacuumed every 6 months to help keep the unit working efficiently.

Open cover and gently vacuum interior of detector trying to keep the nozzle from touching the unit.

WARNING: Never use portable cooking or heating equipment other than electric heaters that are not of the direct radiant type, as it is a fire and asphyxiation hazard.

FIRE EXTINGUISHER

It is recommended that a 1kg (2lb) minimum capacity dry powder fire extinguisher be carried inside your caravan at all times.

When using a dry powder extinguisher it is suggested that the caravan be evacuated until the powder has settled, to avoid inhalation.

A fat pan fire should not have a fire extinguisher aimed at it. It should be smothered with a fire blanket.

WARNING: Provide one dry powder fire extinguisher of an approved type or complying with ISO 7165, of at least 1kg capacity, by the main exterior door and a fire blanket next to the cooker. Familiarise yourself with the instructions on your fire extinguisher and the local fire precaution arrangements.

ESCAPE PATHS

It is important that you do not block escape paths to emergency exits with obstructions or hazards.

CHILDREN

Do not leave children alone in the caravan in any event. Keep potentially dangerous items out of reach, as at home e.g. matches, drugs etc.

VENTILATION

All caravans comply with BS EN 721. The ventilation points on your caravan are fixed points of ventilation which are required by the European Standards.

All caravans have ventilation at high level and low level which have been calculated to suit the individual needs of your caravan.

High level ventilation is achieved by means of the roof lights and washroom roof ventilators. The low level ventilators are positioned underneath the oven housing. Some models with sliding doors have two vents located underneath the sliding doors.

Under no circumstances must these vents be blocked or obstructed.

It is advised that fixed ventilation points are checked and cleaned (if necessary) on a regular basis using a small brush and a domestic vacuum cleaner.

Additional night time ventilation is obtained by releasing the window catches and placing them in the second groove. Note the windows are not sealed from rain in this position.

As the ventilation levels are calculated to suit each models requirements there should be no modifications made which may result in reduced ventilation levels.

WARNING: Do not obstruct ventilation.



Safety & Security

Petrol/Diesel Fumes

The fitting of a tail pipe to your car exhaust will reduce the possibility of fumes entering your caravan through the ventilation points.

Note: Never allow modification of electrical or LPG systems and appliances except by qualified persons at an authorised Swift Group dealership.

SECURITY

Caravan theft

The theft of a caravan can occur in the most unlikely circumstances; from a motorway service area, even from an owner's driveway.

Secure all windows and doors when your caravan is unoccupied even if only for a short length of time.

Chassis number

Record your caravan chassis number which can be found on the **front offside section of the drawbar (Fig. A) or any of the eye level windows.**

Make a note of this number in the space provided at the front of this handbook and make a separate note of the number to keep safe at home.

Additional security

Consider fitting any device which might deter or prevent intrusion by thieves.

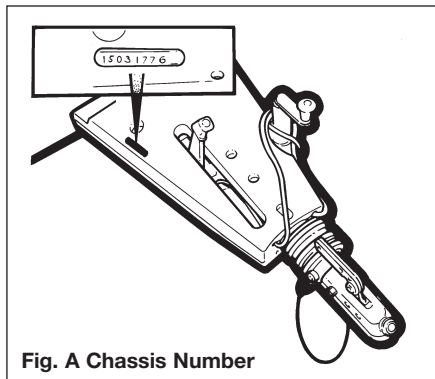

Fig. A Chassis Number

A hitch lock cover prevents towing of the caravan.

A wheel lock prevents towing of the caravan and removal of the wheel.

Customers are advised to identify their caravan with a method for subsequent identification if other forms of identification have been altered or removed.

Free crime prevention advice about securing your caravan, protecting your valuables, property marking, either at home or whilst on site, can be obtained from the Crime Prevention Officer through your local Police Station.

SECURITY CHIPS

A special security chip is concealed within the body of every caravan. This chip contains the individual identity of your caravan and can only be read by using a special decoder. Your local police can obtain the use of a decoder by contacting C.R.I.S. on telephone no: 01722 411430



SERVICES

Connection of Services	22
Water	22
Typical Water Schematic Drawing	22
Truma compact Crystal 2.....	23
Whale Watermaster System.....	24
Whale Supersub System.....	24
Inboard Water Tanks and On-line Water Systems	25
Whale Aqua-Source	25
Reich Microswitch Taps	26
Reich Keramik Twist.....	26
Reich Kama.....	27
Whale 'Elegance' Microswitch Mixer Tap	28
Whale 'Elite' Microswitch Taps	29
Gas	31
General Information.....	31
Typical Gas Schematic Drawing	32
Types of Gas	33
Gas Safety Advice.....	33
Electricity	34
Instructions for Electricity Supply	34
Overseas Connection.....	36
Wiring of Connecting Cable and Caravan Mains Inlet.....	37



Services

Connection of services is dealt with under the separate headings.

In all cases users should become familiar with the equipment manufacturers' instructions.

Advice and leaflets, if not supplied with the caravan, can be obtained from the suppliers of the equipment.

Before making connections of any description to the caravan or its equipment, ensure that ALL equipment is turned off.

WATER

The caravan can use three separate systems for its water supply.

1. External water carrier.
2. Inboard water tank (for winter use essential).
3. Watermaster Aqua Source (mains water).

Typical water schematic drawing with water tank (model specific)

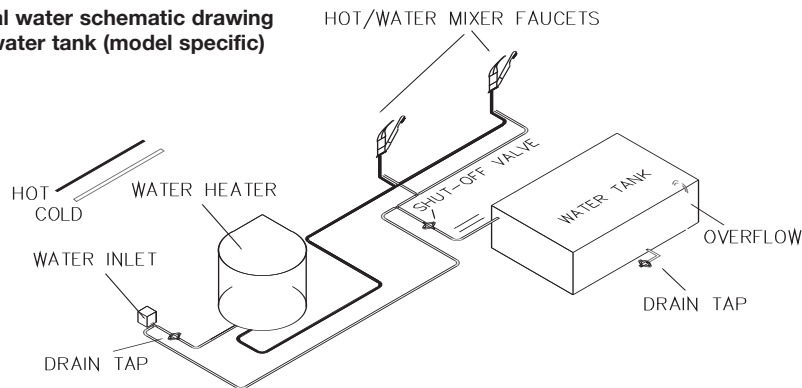

Typical water schematic drawing without water tank (model specific)

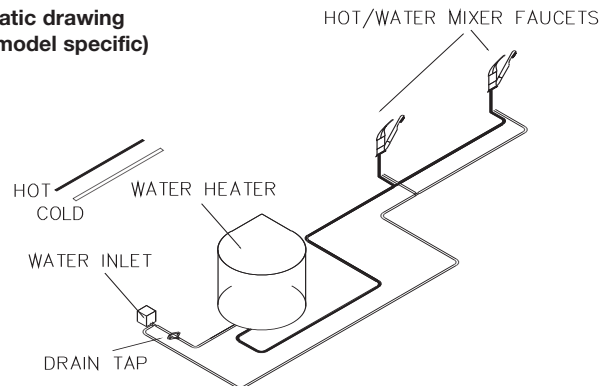

TRUMA COMPACT CRYSTAL 2

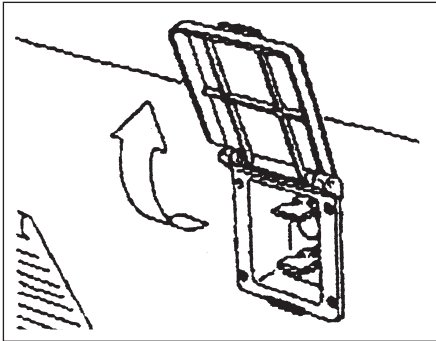

Raise the lid, clean both the water socket and the plug of the pump assembly.

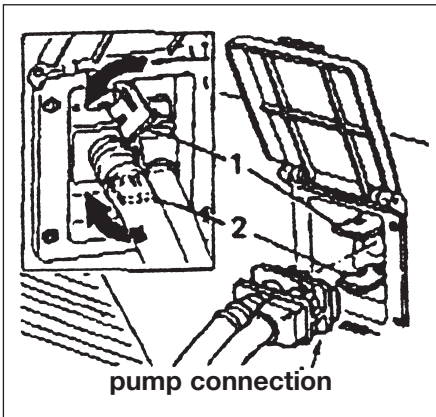

Plug the pump connector into the socket. Turn the top security clip anti-clockwise and the bottom security clip clockwise to lock the plug into place.

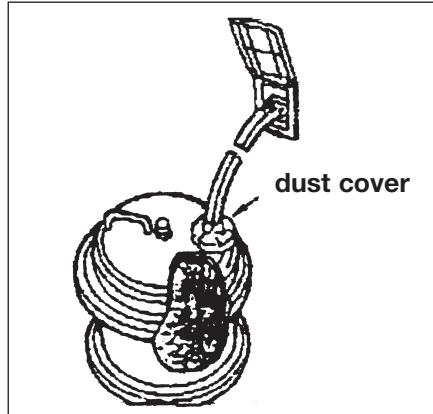

Place the pump into the water container, ensuring that it is fully submerged before operating the system. A dust cover is available to stop contaminants falling into the water container.

To remove the pump assembly from the Crystal Compact Housing, release the security clips and pull the hose adaptor by using the finger grips provided.

Do not remove by pulling the hose or electric cable.

When using the Winter Kit the blanking plug provided will be fitted to the housing not being used.

Clean the water system at the start and end of the season with sterilising fluid (see notes under sterilising).

If the pump fails to deliver water the most likely cause will be air in the system. Switch off the pump and shake the pump assembly in the water. Then switch on again.

STERILISING

1. When cleaning the water system at the start or the end of the season it is advisable to use a sterilising fluid e.g. Chempo SDP or similar.
2. Flush the system thoroughly to remove the effective fluid traces.
3. After sterilising the system at the start of the season it is recommended that a new filter cartridge should be fitted. (Not standard).



Services

WHALE WATERMASTER SYSTEM

Fresh water is supplied to the caravan from an external water container by the Whale Watermaster system, which consists of a socket in the offside exterior wall of the caravan and a separate plug-in pump assembly.

The wall socket is protected by a hinged lid which should be kept shut when the pump is not connected. Never tow the caravan with the lid open. The lid is easily opened by gripping the lower edge and pulling outwards.

To operate the system from the external pump, switch the pump control switch on the electrical panel to external position.

The system will operate as a normal micro-switched system when the taps in the bathroom or kitchen are opened.

WHALE SUPERSUB SYSTEM

The separate plug-in pump assembly consists of a Whale Supersub pump, hose and plug. The plug provides connection of both water supply to the caravan and 12V dc electric power to the pump. A dust cover is fitted to the connecting dual hose to prevent contaminants falling into the water container.

The Whale Supersub pump is a completely sealed unit designed for intermittent use. It is NOT self-priming and therefore to ensure

proper performance, the pump MUST ALWAYS be fully submersed in water BEFORE plugging into the wall socket.

Initial connection to fresh water supply

1. Fill the fresh water container and place it alongside the Whale wall socket located in the offside external wall of the caravan.
2. Ensure the pump isolator switch at the control panel inside the caravan is switched OFF.
3. Open the 'hot' kitchen tap. Ensure all other taps are closed.
4. Place the Whale Supersub pump into the water container outside the caravan, taking care to ensure the pump reaches the bottom of the container.
5. Lift the lid of the Whale wall socket and fit the pump assembly plug into the socket. Ensure it is pressed in fully.
6. Adjust the dust cover to fit over the opening in the water container to keep contaminants out.
7. Switch ON the pump isolator switch at the control panel inside the caravan.
8. Wait until water flows freely from the 'hot' kitchen tap. Allow to flow for a few more seconds to ensure release of any trapped air in the water system, then turn the tap off.

Repeat the same procedure with the 'cold' kitchen tap.

After turning off the taps, check 'pump running' light at the control panel.

If light is OFF — the system is ready for use.

If the system has been drained, the above procedure MUST be repeated EVERY time the water container is filled.

Leave the pump isolator switch at the control panel ON.

Once a tap is turned on, the pump is activated automatically by a micro switch.

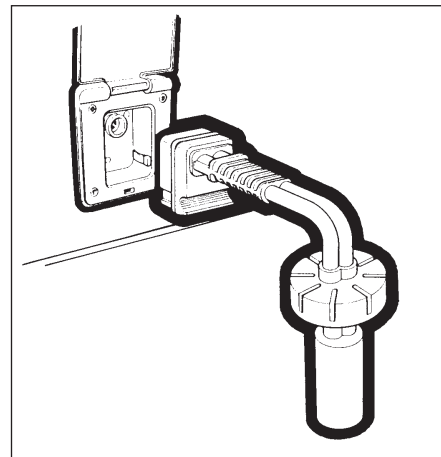

Fault Finding

1. **Pump runs very noisy but does not pump water.** Likely to occur after water container has been refilled. Pump is air locked. Cure: unplug from socket allowing pump to flood, and reconnect by plugging in again. The correct sequence when refilling the container is to unplug, replace pump in container, then reconnect.
2. **Pump does not run at all.** If not due to blown fuse or faulty connections, then most likely cause is excessive continuous running. Cure: replace pump.

Never allow the pump to run dry.

Never allow the pump to run continuously for more than 15 minutes.

Note: When refilling the water container, the pump assembly may be left unplugged into the wall socket so that the pump can be kept off the ground by inserting the hose into the groove on the underside of the plug. But, the pump assembly **MUST** be unplugged **BEFORE** replacing the pump into the refilled water container.

INBOARD WATER TANKS AND ON-LINE WATER SYSTEMS

To fill the inboard/underslung tank from an external container follow these simple instructions:

1. Insert water master pump into container.
2. Plug pump hose connection into water master socket.
3. Ensure the inline stem shut off valve is in the open position (not Cameo). This is located adjacent to the tank or T-connector feeding the tank.
4. On the control panel or above the electrical panel located inside the caravan, turn on the tank fill or auto fill switch (dependant on model). The tank will fill.
 - 5a. Automatic shut-off will take place when the tank is full (Cameo only) or
 - 5b. When water starts to flow from overflow on underside of caravan, or when the container is empty, pull out pump hose connection immediately and turn off switch.
6. On control panel located inside caravan, switch to internal pump and turn on a cold tap for a few seconds to relieve pressure in the tank.

WHALE AQUA-SOURCE

To use an on-line water system (“Aqua-Source”) with an inboard/underslung tank, isolate the tank facility by turning the in-line stem shut-off valve to the OFF position (not Cameo).

Note: It is advisable to check the system for leaks on the first occasion using an on-line water system as they work at slightly higher pressure than pump systems.

The internal and external pumps should NOT be switched on when an on-line pressure system is plugged into the caravan.

WARNING: It is not recommended to tow with water in the onboard or underslung water tank as this could affect stability.

To drain the underslung water tank, reach under the floor and unclip the drain hose, feed the pipe through the chassis holes (if required) to ensure the pipe has a natural fall and open the tap on the end of the drain hose.

To drain the on-board tank open the stem shut off valve adjacent to the tank under the front bed.



Services

REICH MICROSWITCH TAPS

The micro switch taps are used when the water supply is not pressurised.

When the tap is turned on the micro switch (which is fitted inside the tap) activates the pump to supply water.

Operation

Swivel the tap spout (a) to the desired position over the sink, lift the control lever (b) to activate the pump and allow water to flow simultaneously. To adjust the temperature swivel the lever (c) to the left or right as shown opposite.

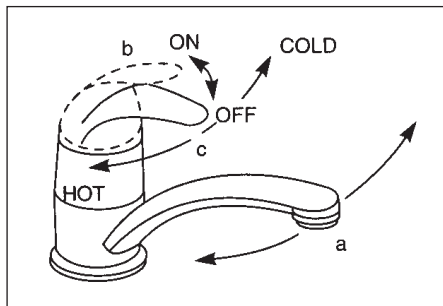

Note: Before commencing microswitch replacement ensure instructions are read through thoroughly. The entire process can be completed without the need to remove the tap from the worktop.

Before you Start

1. Ensure pump is isolated.
2. Position lever in central, i.e. mixer, off location.

REICH TWIST SINGLE LEVER MIXER TAP

Exchange of the ceramic cartridge/ micro switch

1. Detach cover (1) carefully. If the cover is damaged use spare part no.: 240-054312 (red cover) and 240-054313 (blue cover).
2. Loosen screw inside the handle.
3. Detach the handle (2).



4. Detach the housing carefully.



5. Detach the plastic part (3) from the cartridge lever.
6. Loosen screws with screwdriver (Tor® TX6).
7. Detach the plastic ring.
8. Pull out the ceramic cartridge (4).
9. If the cartridge is defect:
 - Install a new ceramic cartridge, part no.: 240-0552M
 - Make sure that the cartridge is in the right position.
10. If the microswitch (5) is defect:
 - Pull the wire out of the mixer
 - Install a new microswitch, part no.: 240-06220M.

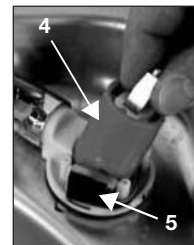
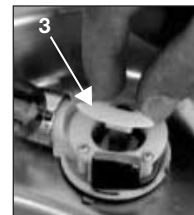

11. Install cartridge, plastic parts, housing and handle in the opposite way.

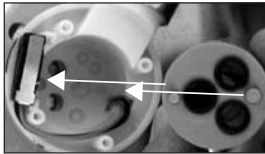

Maintenance

To prevent your single mixer tap TWIST from being impacted by frost, always drain the tap in the middle position of the handle.



The middle position of the handle is marked by an arrow!

REICH KAMA SINGLE LEVER MIXER TAP

Exchange of the ceramic cartridge/micro switch

1. Detach cover (1) carefully. If the cover is damaged use spare part no.: 240-059512 (red cover) and 240-059513 (blue cover).

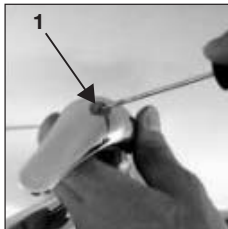

2. Loosen screw inside the handle.

3. Detach the handle (2).

4. Turn out the rosette.

5. Turn out the brass nut with spanner.



6. Pull out the ceramic cartridge (3).

7. If the cartridge is defect:
 - Remove the brass ring (4) from the top of the cartridge
 - Install a new ceramic cartridge, part no.: 240-0528M
 - Make sure that the cartridge is in the right position.

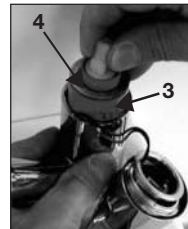

8. If the microswitch is defect:
 - Pull the wire out of the mixer
 - Install a new microswitch, part no.: 240-06220M.

9. Install ceramic cartridge, brass ring, rosette and handle in the opposite way.



Maintenance

To prevent your single mixer tap KAMA from being impacted by frost, always drain the tap in the middle position of the handle.

The middle position of the handle is marked by an arrow!



Services

WHALE 'ELEGANCE' MICROSWITCH MIXER TAPS

The microswitch taps are used when the water supply is not pressurised.

When the tap is turned on, the microswitch (which is fitted inside the tap), activates the pump to supply water.

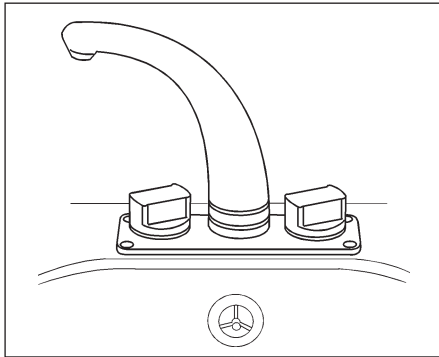

Operation

Swivel the tap spout to the required position over the sink and turn on either the hot or cold tap to activate the pump and allow water to flow. To adjust the water temperature, open both taps to the required mix.

Cleaning

It is recommended that a non-abrasive damp cloth is used for cleaning the Elegance tap.

Microswitch replacement

Before you start:

- Ensure the pump is isolated.
 - Ensure the taps are in the OFF position.
1. Remove the crimp terminals.
 2. Hold the sides of the microswitch clip with your thumb and finger and gently pull off the clip.
 3. The microswitch should slide off the two retaining pins. Be careful not to break the pins off (see fig. 1).
 4. Replace in the reverse order.

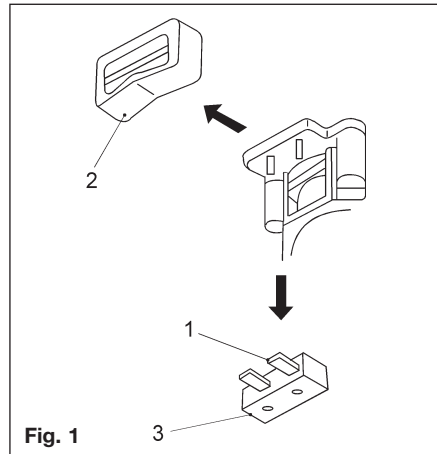

Fig. 1

Dismantling the taps for maintenance

1. Pull off knob(s) and spindle(s).
2. Unscrew securing screw(s), using a 17mm (11/16") spanner.
3. Control unit(s) can now be released for inspection (see fig. 2).

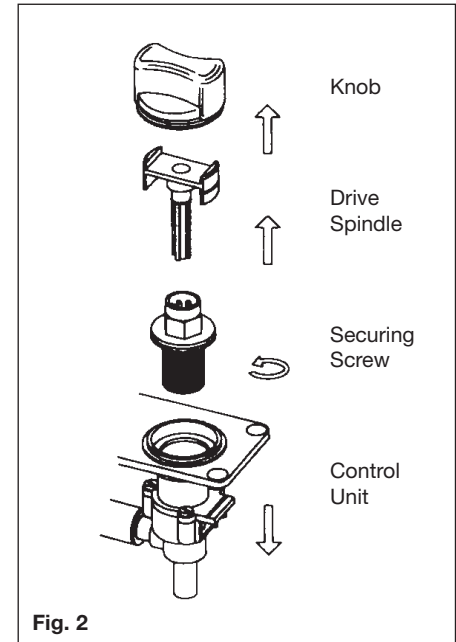

Fig. 2

WINTERISING

To avoid damage as a result of freezing, drain the entire water system. To protect Elegance Tap or Shower units, the tap control(s) and the shower handset on/off control should be opened when draining the system to enable stored water in the outlet to drain back through the control valves and out of the system (switch off pump at isolator). Ensure that both the hot and cold systems are fully drained, the cold drain plug is a separate drain plug from the heater drain plug. Tap spouts and shower heads should be unscrewed, removed and stored in a dry place. Please consult your dealer if in difficulty. If they are unable to solve the problem, contact Whale Customer Services on 01247 270531 ext. 211 or 213.

WHALE 'ELITE' MICROSWITCH TAPS

The micro switch taps are used when the water supply is not pressurised.

When the tap is turned on the micro switch (which is fitted inside the tap) activates the pump to supply water.

Operation

Swivel the tap spout (a) to the desired position over the sink, lift the control lever (b) to activate the pump and allow water to flow simultaneously. To adjust the temperature

swivel the lever (c) to the left or right as shown below.

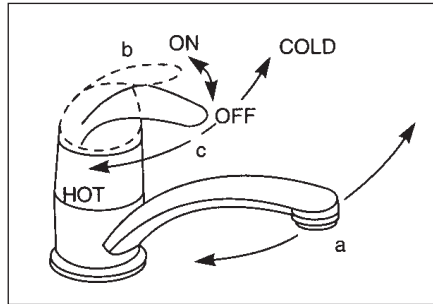

Cleaning

It is recommended that a non-abrasive damp cloth is used for cleaning the Elite Tap/Shower.

Microswitch Replacement: A microswitch replacement kit is available (ref. MT8000).

Note: Before commencing microswitch replacement ensure instructions are read through thoroughly. The entire process can be completed without the need to remove the tap from the worktop.

Before you Start

1. Ensure pump is isolated.
2. Position lever in central, i.e. mixer, off location.

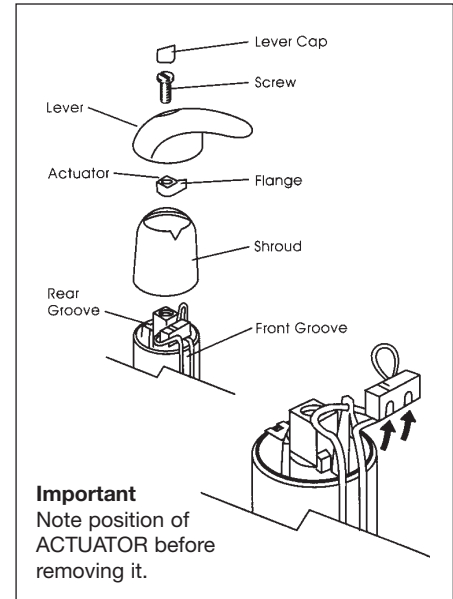

Important

Note position of ACTUATOR before removing it.

Microswitch Replacement

1. Carefully remove lever cap. A recess at the back of the lever cap is provided to assist with this.
2. Remove screw with No. 2 Pozzi screwdriver. Note the position of the lever at this stage.
3. Lift off the lever.



Services

- Note the position of actuator before removal. Flange should be facing forward.
- Remove actuator.
- To remove shroud, squeeze clips with one hand and slide shroud off with other hand.
- Remove microswitch, using finger and thumb, pull up and outwards.
- Slide wire terminals off microswitch.
- Attach replacement microswitch and relocate. **Note:** Ensure microswitch snaps fully home.
- Before relocating shroud ensure wires are neatly located in the front groove as shown.
- Replace shroud. **Note:** Ensure shroud locating rib is aligned with the rear groove of tap and snap fully home, ensuring clips are retaining the shroud.
- Replace actuator in position noted in 4 above.
- Replace lever and fix with screw.
Note: Do not overtighten screw.
- Replace lever cap.

WINTERISING

To avoid damage as a result of freezing, drain the entire water system. To protect Elite tap or shower units, the tap control(s) and the shower control should be opened when draining the system to enable stored water in

the outlets to drain back through the control valves and out of the system. (Switch off pump at isolator). Ensure that both the hot and cold systems are fully drained by draining separately. The cold drain plug is a separate drain plug from the heater drain plug. The lever should be up and in the centre to drain the hot and cold system when not in use. Remove water filter if fitted. Please consult your dealer if in difficulty. If they are unable to solve the problem, contact Whale Customer Services: tel: 01247 270531 ext. 211 or 213.

GUIDANCE ON CLEANING PORTABLE WATER TANKS AND THE WATER SYSTEM IN TOURING AND MOTOR CARAVANS

The water systems, and in particular storage tanks, in caravans are susceptible to contamination by bacteria if care is not taken with their use and cleaning. The symptoms caused by bacterial contamination are not purely limited to gastro-intestinal diseases, but may also manifest themselves as ear, nose, throat, eye or skin infections. It is therefore important that you carry out the following procedure prior to using the caravan each time, even if you boil or filter all water you use for drinking.

Separate Water Containers

- All water remaining in the container should be disposed of so that the container is empty.

- The outside of the container should be thoroughly cleansed and washed down to remove any dirt, dust or other contaminant. Water at a suitably hot temperature containing an appropriate detergent is recommended for this purpose.
- Water should be put in the container, swirled around, then emptied out.
- The container should then be totally filled with water containing an appropriate sterilant solution and allowed to stand for the recommended contact time (e.g. Milton for 15 minutes).
- The solution should be emptied from the container.
- The opening of the container should be cleaned thoroughly with an appropriate prepared wipe impregnated with a sterilant.
- The container should be inverted whilst stored overnight (if possible).
- The container must be filled with mains water only and mains water only should be used for the above cleaning procedure.
- On no account should garden hoses be used to fill water tanks.

For Systems:

1. Drain down the system (open all taps to allow air in, enabling the system to drain quickly). (See Maintenance Systems).
2. Remove any water filters fitted, and replace with a short length of hose or empty filter cartridge (this will ensure the filter is not affected by the disinfectant/sterilant solution).
3. Fill the system by using the pump with a disinfectant/sterilant solution (check that the solution at full strength appears at all taps/showers). Allow to stand for the recommended period of time.
4. Drain the system completely.
5. Thoroughly clean the outside of all taps/connectors with a cloth soaked in the disinfectant/sterilant.
6. Flush the system through with clean drinking water until no traces of disinfectant/sterilant can be detected at any tap.
7. Replace the filter.

Suitable sterilising chemicals are available from your caravan dealer, accessory shop, chemist or home-brew shops. It is not, however, recommended to use bleach or sodium metabisulphite.

This guidance has been prepared with the kind co-operation and assistance of The

Environmental Health Department of The Borough Council of King's Lynn and West Norfolk.

WARRANTY

Products are guaranteed from the date of purchase against defects in materials and workmanship. If the unit proves faulty, return it to your supplier with proof of purchase and purchase date. Please note that frost damage is not a valid warranty claim.

The manufacturer retains the right to repair or replace the unit. The manufacturer cannot be held responsible for claims arising from incorrect installation, unauthorised modification or misuse of the product. The above does not affect your statutory rights.

GAS

GENERAL INFORMATION

Gas Bottles

Bottled Liquefied Petroleum Gas (LPG) is the most convenient portable source of fuel for your caravan.

Make sure that heating and cooking appliances and the gas cylinders are switched off before you move the caravan.

Regularly check flexible gas hose, joints and connections for tightness. Finally make sure that each gas appliance is working efficiently to the recommendations of the appliance manufacturers.

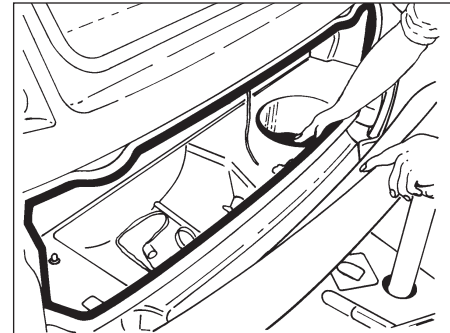

Fig. A Gas Bottle Compartment

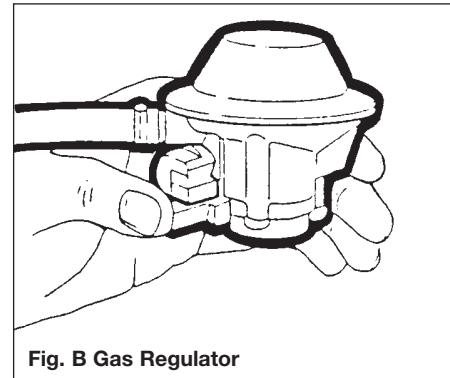
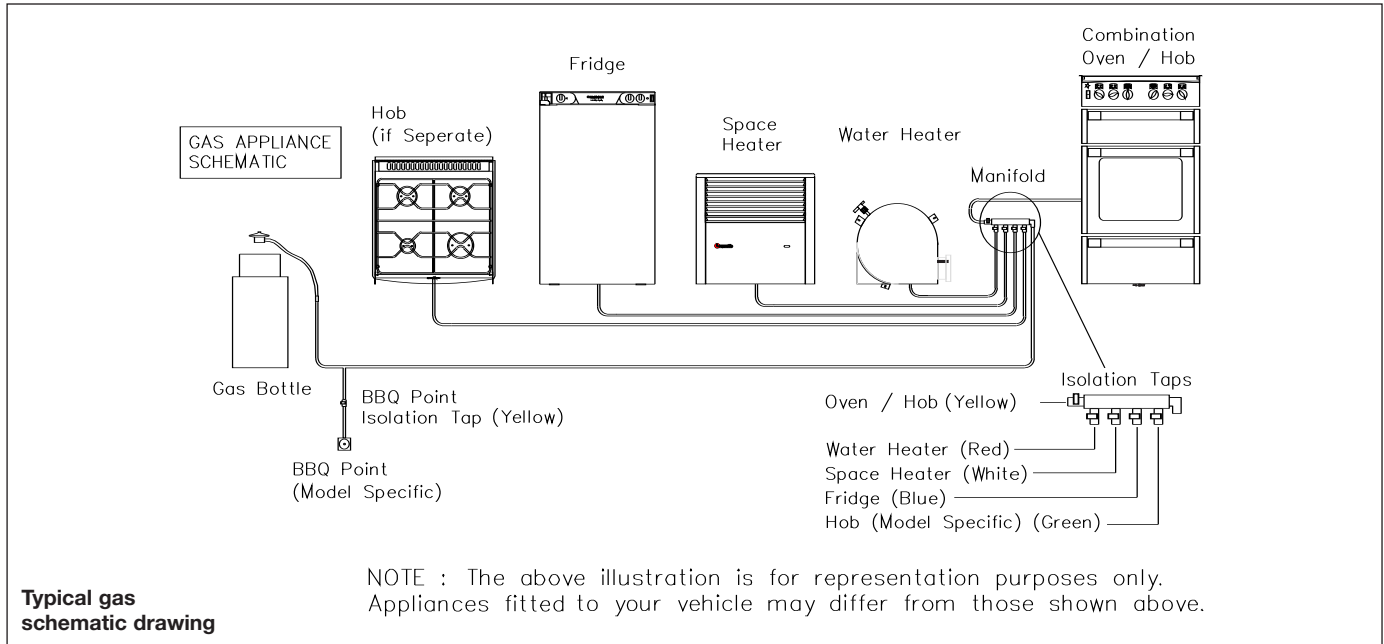

Fig. B Gas Regulator



Services



The regulator

The regulator (Fig. B) is a governing device which adapts the bottle pressure to one that suits the equipment in the caravan.

Note: Regulator valves should always be in the 'OFF' position when towing.

WARNING: Some industrial LPG appliances operate at high pressure and require a 'high pressure' regulator. This often has an adjusting handle on it. NEVER use such a regulator on a caravan.

Propane and Butane gas regulators are not interchangeable.

Cylinders and regulators are also not interchangeable between different makes of gas cylinder.

Hoses

Hoses should be made from Neoprene and should conform to BS 3212. Rubber hosing should never be used. It is good practice to replace hoses annually, and a jubilee clip is a worthwhile addition to prevent accidental removal of the hose.

WARNING: Inspect flexible gas hose regularly for deterioration and renew, as necessary, with the approved type. In any case the hose should be renewed not later than the expiry date marked on the hose. Flexible gas hose length should not exceed 400mm.

WARNING: Ensure hoses do not become entangled in door mechanism.

TYPES OF GAS

Butane

Butane is supplied in the U.K. in green, blue or aluminium bottles.

All these have a male left hand thread EXCEPT for Camping Gaz which has a special female right hand thread and Calor 7kg and 15kg and aluminium bottles which have a special clip-on connection.

A 7kg bottle is recommended for butane gas.

Continental bottles usually have a male left hand thread similar to but not identical with U.K. butane.

Butane is suitable for use at temperatures down to 2°C but will not work below that.

Propane

Propane is supplied in Red, or partly red bottles which have a female left hand threaded connector.

Scandinavian countries use the same connector.

Germany and Austria supply propane with a male connection.

Propane will work at temperatures as low as -40°C and is therefore suitable for all winter caravanning.

A 6kg bottle is recommended for propane gas.

GAS SAFETY ADVICE

WARNING: If you smell gas or suspect a leak and if it is safe to do so, isolate the gas appliances and turn off the gas bottles at the regulator. Evacuate the caravan and ventilate. Seek professional advice as to the cause of the leak.

Facts about LPG

LPG is not poisonous.

Bi-products are harmless.

There is danger if all air and oxygen were excluded.

(Ventilation holes must be kept clear at all times).

LPG has been given a smell by the manufacturers in order to identify leaks.

Awning Spaces LPG Appliance Exhaust

There is no danger of pollution of an enclosed awning space by the LPG exhaust from a refrigerator venting into it, as awning spaces are generally well ventilated.

Space heaters may produce sufficient exhaust to pollute the awning space, if it is totally enclosed, from a general comfort, smell and hygiene point of view. In the extreme case there could be a build up of carbon dioxide to a dangerous level.

Caravan owners are advised to allow some fresh air circulation in the awning space when such appliances are in use.

PRECAUTIONS

- a) Never look for a leak with a match. Always use a soap solution or its equivalent when testing connections. Do not operate any electrical apparatus whatsoever, especially light switches. If the leak is not obvious, the caravan should be evacuated and qualified personnel consulted.
- b) Avoid naked lights when connecting or changing a cylinder.



Services

- c) Check the flexible hose frequently.
- d) The gas is heavier than air and therefore sinks to the lowest point.
- e) Keep bottle gas containers outside (and protected against frost). If they must be kept inside make sure they are well away from heat.

Ventilation

All ventilation complies with BSEN 721 and vents should not be obstructed in any manner as this could lead to insufficient fresh air. In this case the confined atmosphere becomes depleted of oxygen which leads to the formation of the highly poisonous gas 'carbon monoxide'. Carbon Monoxide is odourless, colourless and tasteless and will rapidly cause unconsciousness and death with little or no warning prior to collapse. THERE IS NO DANGER WHEN ADEQUATE VENTILATION IS PROVIDED.

Roof-mounted Flue installations

All flue installations should be inspected once a year throughout their length for corrosion. Flues should be replaced if any sign of perforation is found. Ensure that the replacement is of an approved type.

CONNECTION

Ensure that the gas regulator is correctly connected to the gas cylinder in gas bottle compartment and that the hose is tight.

Before turning on the gas supply, ensure that all gas operated equipment in the caravan is turned off.

All gas equipment (except barbecue) is supplied through a central Gas Manifold System which has individual isolation taps for each appliance, as follows:

- RED - Water Heater
- WHITE - Space Heater
- BLUE - Fridge
- GREEN - Hob (Separate)
- YELLOW - Hob & Oven (Combination)
- YELLOW - Barbecue (if fitted)

Note: the external barbecue point is fed from the main feed through an isolation tap. See schematic layout for details.

Thermal insulation heating

Your caravan has been designed to achieve a thermal insulation and heating level for specific climatic conditions when tested according to the procedure in EN1645-1. The classifications are as follows:

GRADE 1

A caravan with an average thermal transmittance (u) that does not exceed 1.7w/(m²k).

GRADE 2

A caravan with an average thermal transmittance (u) that does not exceed

1.7w/(m²k) and which can achieve an average temperature difference of at least 20k between inside and outside temperatures when the outside temperature is 0°C.

GRADE 3

A caravan with an average thermal transmittance (u) that does not exceed 1.2w/(m²k) and which can achieve an average temperature difference of at least 35k between inside and outside temperatures when the outside temperature is -15°C.

ELECTRICITY

As with electricity in the home, care must be exercised when handling mains electricity.

Your attention is drawn to the following notice as laid down by the Institute of Electrical Engineers.

INSTRUCTIONS FOR ELECTRICITY SUPPLY

On arrival at caravan site

1. Before connecting the caravan installation to the mains supply, check that
 - (a) both 12N & 12S plugs and hitch have been disconnected from the towing vehicle,
 - (b) the mains supply is suitable for your installation and appliances, i.e. whether it is a.c. or d.c. and whether it is at the correct voltage and

frequency,

- (c) your installation will be properly earthed. Never accept a supply from a socket outlet or plug having only two pins, or from a lighting outlet, and
- (d) any residual current device (earth leakage circuit breaker) in the mains supply to the caravan has been tested within the last month.

In case of doubt, consult the site owner or his agent.

2. **MAKE SURE THAT THE SWITCH AT THE SITE SUPPLY POINT IS OFF.**
3. Lift the cover of the electricity inlet provided on the caravan, and insert the connector of the supply flexible cable.
4. Remove any cover from the socket outlet provided at the site supply point, and connect the plug at the other end of the supply flexible cable to this. Switch on the main switch at the site supply point.

Note: Use mains cable fully uncoiled and protect from traffic.

IT IS IMPORTANT THAT THE MAIN SWITCH AT THE SITE SUPPLY POINT SHOULD BE SWITCHED OFF, THE SUPPLY FLEXIBLE CABLE DISCONNECTED, AND ANY COVER REPLACED ON THE SOCKET OUTLET AT

THE SITE SUPPLY POINT BEFORE DISCONNECTING THE FLEXIBLE CABLE FROM THE CARAVAN. IT IS DANGEROUS TO LEAVE THE SUPPLY SOCKET OR SUPPLY FLEXIBLE CABLE LIVE.

Because touring caravans are generally left unused for long periods in the open, it is strongly advised that the mains installation is inspected periodically to ensure that it is safe to use. The IEE Wiring Regulations recommend that mains installations in touring caravans are re-inspected every 3 years by a qualified person (see list) who should sign and issue a periodic inspection report. (The manufacturer recommends annual inspections).

Suitably qualified persons acceptable to the NCC to sign and issue inspection and completion certificates are:

- an approved contractor of the National Inspection Council for Electrical Installation Contracting* or
- a member of the Electrical Contractors' Association
- a member of the Electrical Contractors' Association of Scotland
- a qualified person acting on behalf of the above (in which event it should be stated for whom he is acting).

**The names and addresses of Approved Contractors in any locality (there are over 10,500 in the UK) can be obtained from Electricity Shops, or direct from:*

NICEIC, Vintage House,
37 Albert Embankment, London SE1 7UJ
Telephone: 0171 582 7746

The names and addresses of members of the Electrical Contractors' Associations can be obtained direct from:

ECA, Esca House,
Palace Court, London W2 4HY

Telephone: 0171 229 1266

ECA of Scotland, 23 Heriot Row
Edinburgh EH3 6EW

Telephone: 0131 225 7221



WARNING: CURRENT CONSUMPTION IN THE CARAVAN MUST NOT EXCEED 16 AMPS OR THE PITCH PERMITTED MAXIMUM IF THIS IS LESS THAN 16 AMPS.

IT IS DANGEROUS TO ATTEMPT MODIFICATIONS AND ADDITIONS YOURSELF. LAMPHOLDER—PLUGS (BAYONET-CAP ADAPTORS) SHOULD NOT IN ANY CIRCUMSTANCES BE USED.

Services

CAUTION

The Ultraheat has the potential to draw 8 amps at 2kW. An ALDE heater has a potential drain of 3kW/13amp. It is, therefore, advisable to check the supply rating before switching on two loads (items) greater than the supply as this may cause an overload and the circuit breaker to trip.

OVERSEAS CONNECTION

Note: Connection to a mains voltage supply OVERSEAS requires particular attention.

Care must be taken when connecting supplies abroad since the supplies can be of REVERSE POLARITY.

The significance of REVERSE POLARITY is that when equipment is switched off it may not be electrically isolated.

The only certain way of making equipment safe is to unplug it.

It is useful to have a means of checking polarity of the mains supply, especially when touring overseas. There are available several proprietary makes of equipment for testing polarity.

If it can be achieved, it is preferable to connect live to live, and neutral to neutral to maintain full electrical protection.

WIRING OF CONNECTING CABLE AND CARAVAN MAINS INLET

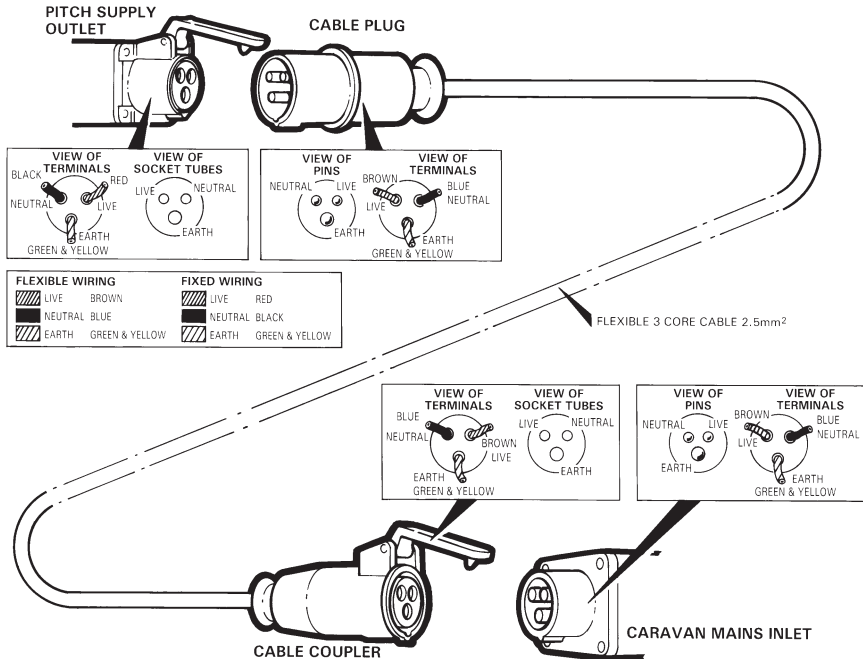

WARNING

IT IS ESSENTIAL THAT CONNECTIONS ARE MADE EXACTLY AS SHOWN. IF TERMINAL MARKINGS ARE NOT IN ACCORDANCE WITH THE DIAGRAM THEY MUST BE IGNORED. IF IN DOUBT CONSULT A QUALIFIED ELECTRICIAN.
THE LEGAL LENGTH OF THE MAINS INLET CABLE IS 25 ± 2 METRES. WHEN IN USE IT MUST BE FULLY UNCOILED AND PROTECTED FROM TRAFFIC.



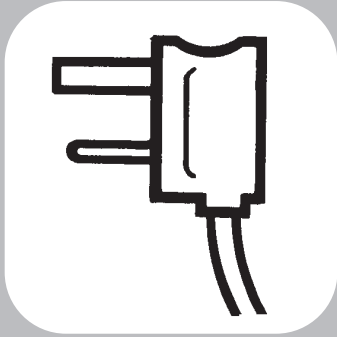

ELECTRICAL EQUIPMENT

Distribution Panels	40
KT9/2000 GL, GX, GT, GS	41
KT9/2000 BT, GP	41
Remote Control Instructions	42
ESM 2 - Electrical Supply Module	43
ECM - Electrical Control Module	44
ESM 2000 - Electrical Control Module	44
Battery	46
Habitation Relay	46
Generator Guidelines	46
Alarm Module IDM 2000	47
12V Electrical Supply	50
Wiring of 12S Socket to Towing Vehicle	51



Electrics

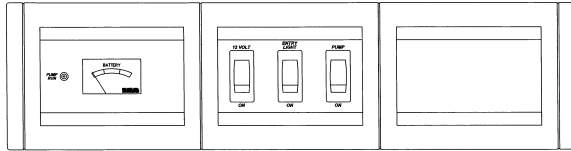

KT9/2000GL

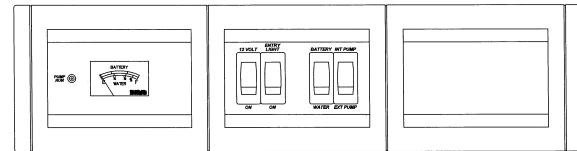

KT9/2000GS

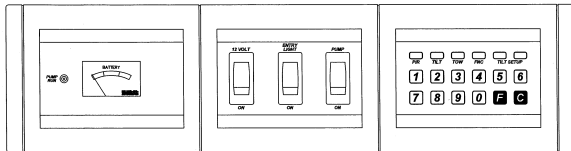

KT9/2000GX

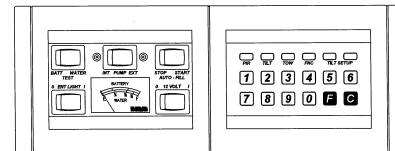

KT9/2000BT

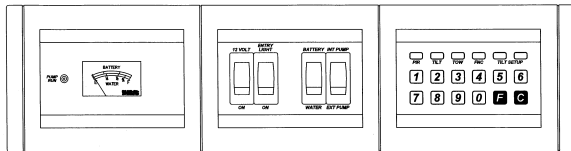

KT9/2000GT

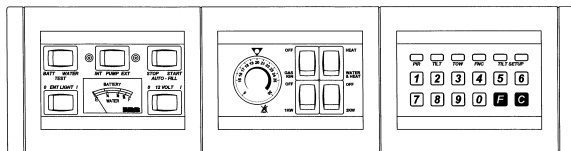

KT9/2000GP

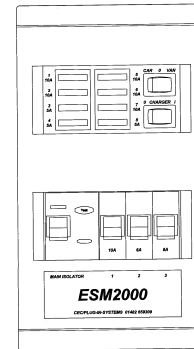

ESM2000

DISTRIBUTION PANEL - KT9/2000GL, GX, GT, GS for specific models

Indicator Module

*Battery / Water Level Meter
(KT9/2000GT/GS only)*

This meter indicates the amount of fresh water remaining in the inboard water tank. Simply press the test switch to the water position and the meter will display a level on the following scale:

Empty - $1/4$ - $1/2$ - $3/4$ - Full

To test battery voltage simply press the test switch to the battery position, readings should be taken as shown below.

*Battery Condition Meter
(KT9/2000GL/GX only)*

This battery condition meter indicates the power remaining in your caravan battery. Readings should be taken as follows:

Green region - Fully charged
(no charge necessary)

Yellow region - Adequate charge
(re-charge if desired)

Red region - Low charge
(turn on charger switch
to re-charge)

Also included in this module is a pump running indicator. This red indicator will light up as a warning when the water pump has been activated.

Switch Module

This module contains all the control switches for electrical facilities within the caravan.

12V Isolation Switch

This switch will effectively isolate 12 volt power to all dc circuits by opening a relay. This switch should be used only when wishing to isolate power for reasonably short periods (e.g. when going out for the day). For isolation during storage the Car/Van switch on the ESM2000 unit should be used (place Car/Van switch to the centre 'off' position)

Pump switch

This switch merely energises the inboard water pump ready for use. In caravans with an outboard pump, this switch will be a two way type for energising whichever pump is required (i.e. internal or external)

Entry Light switch

This switch energises an internal entry light.

Battery / Water test switch (KT9/2000GT/GS only)

This switch should be pressed to the battery position to test battery voltage or the water position to test the water remaining in the inboard tank.

DISTRIBUTION PANEL - KT9/2000BT, GP for specific models

Switch & Indicator Module

Water Level Meter

This meter indicates the amount of fresh water remaining in the inboard water tank. Simply press the test switch to the water position and the meter will display a level on the following scale:

Empty - $1/4$ - $1/2$ - $3/4$ - Full

Battery Condition Meter

This battery condition meter indicates the power remaining in your caravan battery. To test battery voltage simply press the test switch to the battery position, readings should then be taken as follows:

Green region - Fully charged
(no charge necessary)

Yellow region - Adequate charge
(re-charge if desired)

Red region - Low charge
(turn on charger switch
to re-charge)

Pump switch

This switch merely energises the inboard water pump ready for use. In caravans with an outboard pump, this switch will be a two way type for energising whichever pump is



Electrics

required (i.e. internal or external). The RED indicator associated with the pump chosen, will illuminate when the pump is on.

Entry Light switch

This switch energises an internal entry light.

Battery / Water test switch

This switch should be pressed to the battery position to test battery voltage or the water position to test the water remaining in the inboard tank.

Auto-fill Start/Stop switch

This switch is a part of the automatic water filling system and controls the filling process from the external to internal water tanks. The Auto-Fill system is operated by the WLS/S/A unit mounted near to the internal water tank. This unit controls the filling of the Internal Fresh Water Tank from an external pump, the filling process is automatically stopped if: -

- i) The water tank is full.
- ii) The pre-set timer period expires (approx. 3min).
- iii) The control switch is pressed to the 'off' position

These operations are controlled from the Auto-fill START / STOP switch incorporated in the KT9/2000 Panel and an AUTO/OFF/MANUAL switch, which is positioned on the Auto-fill unit.

The function and operation of these switches is described below: -

Auto - In this position the Auto-fill system is enabled. Control of the system is passed to the Auto-fill Start/Stop switch on the KT9/2000 Panel. NB. *Keep the switch in this position for normal use.*

Off - In this position the Auto-fill system will be disabled. This means it will not be possible to fill the internal water tank directly from external pump.

Manual - In this position the external pump will be directly switched on and will remain energised until this switch is moved out of this position.

The manual position also allows direct filling of the internal tank from the external inlet via Aqua-source or hosepipe. NB. *The auto cut-off and water level monitoring does not operate in manual override.*

Start/Stop - When the switch is depressed in the Start direction the external pump will start and run until:

- i) A Tank full sensing stud is reached.
- ii) The pre-set timer period is expired (approx. 3min).
- iii) The momentary control switch is depressed into the Fill-Off position.

NB. *When the Auto-fill process is started the Water level meter will also be activated this allows monitoring of the water tank as it fills.*

12V Isolation Switch

This switch will effectively isolates 12 volt power to all dc circuits by opening a relay. This switch should be used only when wishing to isolate power for reasonably short periods (e.g. when going out for the day). For isolation during storage the Car/Van switch on the ESM2000 unit should be used (place Car/Van switch to the centre 'off' position).

Note: On models with ALDE central heating the isolation switch excludes the heating system.

REMOTE CONTROL INSTRUCTIONS

Some models are equipped with a remote control unit which allows the user to isolate the caravan outputs from the battery, using button II, whilst still maintaining the charging of the battery (when connected to a mains supply). It can also switch on the entry light inside the caravan, using button I.

1. Button I controls the first light inside the caravan.
2. Button II controls the isolation of the 12 V systems.

Overriding the remote control is possible by using the two switches located on the control panel above the door. These switches should be left in the OFF position when using the remote control during normal operations.

Important Note: Ensure that the polarity of the caravan battery is correct, as reverse connecting the battery may damage the control unit.

Switching current should be limited to 1.0 Amp DC at 12 V.

On the rear of the control is a UH number, make a note of this and remove. This number is to be used when obtaining a replacement or additional control.

ESM 2 ELECTRICAL SUPPLY MODULE

The ESM 2 Electrical Supply Module from Plug-In-Systems Ltd is a 230V mains and 12V DC power supply unit, providing all the necessary features for supply of electric in your caravan. The unit provides the following important features.

Connections

Plug & socket input/outputs

Mains 230V AC

Mains module with
Earth leakage protection (RCD)
Overcurrent protection (MCBs)

12V DC

Fully automatic transformer/charger with
Overcurrent protection
Short circuit protection
Charger on/off switch

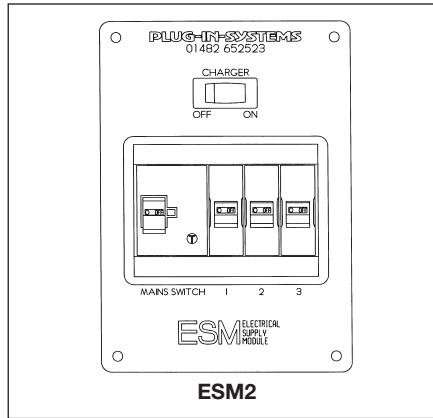

UNIT DESCRIPTION

Mains Module

The ESM 2 is designed to operate on a mains supply of 185-265 volts ac (making it ideal for use with low continental voltages). The 40 amp RCD (Residual Current Device) gives protection against earth faults and also acts as the main switch.

The mains module also has three MCBs (Miniature Circuit Breakers) which are basically resettable mains fuses, to protect against overcurrent. Allocation of the MCBs is as follows:

- MBC1- Sockets/Space Heater (if fitted)
- MBC2- Space Heater/Lights (if fitted)
- MBC3- Fridge/Charger

TRANSFORMER/CHARGER

The ESM 2 employs a fully automatic mains transformer and battery charger, able to operate with a wide range of input voltages and provide a stable output voltage even under load.

The unit can provide up to 12 amps maximum, after which it will begin to shut down to protect itself.

To use the charger simply place the rocker switch to the ON position, at which point it should illuminate and charging will commence.

ROADS LIGHTS FUSES

The fuses are located on the front bulkhead of the right hand front locker.

Fuse Ratings

1	LH ROAD	5A
2	RH ROAD	5A
3	LH INDICATOR	7.5A
4	RH INDICATOR	7.5A
5	FOG	7.5A
6	STOP	7.5A



Electrics

ECM ELECTRICAL CONTROL MODULE

PUMP SWITCH & INDICATOR

Included on this panel is a pump isolation switch and pump running indicator. The pump isolation switch is used to isolate power to the water pump in the event of a pump fault or merely as a safeguard against unwanted pump operation. The red pump running indicator will light up as a warning when the water pump has been activated.

AUX SWITCH

This switch may be used to power any auxiliary dc circuits the user may wish to have added to the system.

Battery Condition Meter

This meter indicates the power remaining in your caravan battery.

Readings should be taken as follows:

- Green region - Fully charged
(no charge necessary)
- Yellow region - Adequate charge
(re-charge if desired)
- Red region - Low charge
(turn on charger switch to re-charge)

A car/caravan changeover switch is provided in this module and should be used in the following way:

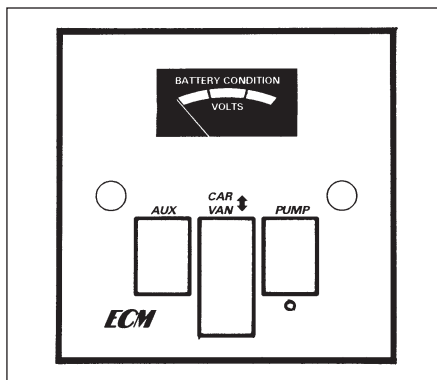

Caravan position

When in this position dc power is available from the caravan battery to power all 12 volt electric circuits. If the charger is switched ON the caravan battery will be charged up via the charger/transformer unit.

Central position

When in this position with the charger switch ON, power is provided to all 12 volt circuits via the charger/transformer only. With the charger OFF all dc circuits are isolated.

Note: The switch should be placed in this position when the van is being towed.

Car position

Note: First of all the towing vehicle should be electrically connected to the caravan via the 12S socket.

The switch can be placed in this position should the caravan battery become discharged and no mains power is available.

ELECTRICAL SUPPLY MODULE ESM2000

The ESM2000 Electrical Supply Module is a 230 volt ac and 12 volt dc power control unit. It provides all the necessary features for control of the electrics in a caravan. The unit provides the following features:

Mains 230V ac - MAINS MODULE

with EARTH LEAKAGE PROTECTION
OVERCURRENT PROTECTION (RCD)
REVERSE POLARITY INDICATION

12 volt dc - FULLY AUTOMATIC TRANSFORMER/CHARGER

with OVERCURRENT PROTECTION
SHORT CIRCUIT PROTECTION

SWITCH & FUSE MODULE

with BATTERY CHANGEOVER SWITCH
CHARGER ON/OFF SWITCH
8 FUSED DC OUTPUT CIRCUITS

UNIT DESCRIPTION

Mains Module

The ESM2000 is designed to operate on a mains supply of 207 - 253 volts ac (making it ideal for use with low continental voltages). The 40 amp RCD (Residual Current Device) gives protection against earth faults and also acts as the main switch. The mains module also has three MCB's (Miniature Circuit

Breakers) which are basically resettable mains fuses, to protect against overcurrent. Allocation of the MCB's is as follows:-

For Abbey, Sterling and Swift models

MCB1 - SOCKETS/BLOWN-AIR HEATING
(if fitted)

MCB2 - WATER HEATER/LIGHTS (if fitted)

MCB3 - FRIDGE/CHARGER

For Bessacarr models

MCB1 - HEATING SYSTEM

MCB2 - SOCKETS

MCB3 - LIGHTS/FRIDGE/CHARGER

Using a generator

When using a generator in conjunction with the ESM2000 the following must be observed, failure to do so may result in damage to the unit:

- i) Always start the generator with the mains isolator in the caravan turned off.
- ii) Allow the generator to warm up for a few minutes before energising power in the caravan, as the output voltage can be higher when cold.
- iii) Check the generator output voltage regularly to ensure it is within the specification of the ESM2000 system (i.e. 230 volts +/- 10%)

Transformer/Charger

The ESM2000 employs a fully automatic mains to 12 volt dc transformer and battery charger, able to operate with a wide range of input voltages and provide a stable output

voltage even under load. The unit can provide upto 12 amps maximum, after which it will begin to shut down to protect itself.

Switch & Fuse Module

Car/Van Selector Switch

The car/caravan changeover switch provided in this module should be used in the following way:

Caravan position -

When in this position dc power is available from the caravan battery to power all 12 volt electric circuits.

If the charger is switched on, the caravan battery will be charged via the charger/transformer unit.

Central position -

When in this position with the charger switch on, power is provided to all 12 volt circuits via the charger/transformer only.

With the charger off all dc circuits are isolated.

Note: The switch should be placed in this position when the van is being towed.

Car position -

The switch can be placed in this position should the caravan battery become discharged and no mains power is available.

Note: First of all the towing vehicle should be electrically connected to the caravan via the 12S socket.

Charger switch

When the caravan battery requires charging, press this switch to the on position (it should then illuminate). Also ensure the Selector Switch is in the van position.

DC Fuses

Eight fuses are provided in this module to protect all dc circuits, the fuse allocation is shown below. Fuses must be replaced only with the specified values.

For KT9/2000 GL, GX, GT, GS

Distribution Panels

Fuse 1 - Front roof lighting

Fuse 2 - Rear roof lighting

Fuse 3 - Blown-Air Heating

Fuse 4 - Radio

Fuse 5 - 12v sockets/Hitchlight/TV amp

Fuse 6 - Fan circuits

Fuse 7 - Water pumps/Water sensor/
Thetford toilet

Fuse 8 - Ignitions

For KT9/2000 BT, GP Distribution Panels

Fuse 1 - Front roof lighting

Fuse 2 - Rear roof lighting

Fuse 3 - Heating System

Fuse 4 - Radio

Fuse 5 - 12v sockets/Hitchlight/TV amp

Fuse 6 - Fan circuits

Fuse 7 - Water system/Thetford toilet

Fuse 8 - Ignitions

Note: For models fitted with Primus central heating, there is an additional 10 amp fuse located behind the ESM 2000 distribution panel.



Electrics

BATTERY

It is recommended that a good quality leisure battery is always in circuit when the system is in use.

A deep cycling heavy duty 12v battery should be purchased to provide power for lights and other electrical appliances. A proprietary brand leisure battery with either a 60 or 90amp capacity is recommended.

Note: 90 amp batteries and above should be checked dimensionally before purchasing, to ensure fitment within the battery compartment, as brands vary in size.

It should be remembered that batteries suitable for the electrical demands of a caravan differ in design from those for use with a car, and whilst the system may operate with a car battery it is strongly recommended that only a leisure type battery, maintained in good condition is used. The battery should be kept topped up at all times.

The battery should be positioned in a compartment vented to the outside and should be properly secured.

WARNING: When connecting the battery, ensure that the correct polarity is observed (black is negative and red is positive) and that the terminals are securely fastened.

Under normal circumstances it should not be necessary to remove the battery other than for routine inspection of terminals and "topping up".

WARNING: Explosive gases may be present at the battery. Take care to prevent flames and sparks in the vicinity.

Your caravan has been fitted with an in-line fuse between the battery terminal and strip connector. It is recommended that the fuse rating fitted in this location does not exceed 20 amps.

WARNING: Switch off all appliances and lamps before disconnecting the battery.

Smoking is prohibited around the battery compartment.

To preserve the life of your leisure battery and charger please observe the following:

- i) Do not leave all 12v lights powered at the same time as this will drain your leisure battery more rapidly.
- ii) If all 12v lights must be powered together, ensure the battery is 'in-circuit' i.e. selector switch in the 'van' position and that the battery charger is turned on.
- iii) For optimum performance use the transformer/charger unit with a leisure battery attached.

SUPPORT SERVICE

PLUG-IN SYSTEMS LIMITED PROVIDE AN ON-CALL SERVICE FOR WARRANTY OR NON-WARRANTY REPAIRS.

IF YOU WISH TO TAKE ADVANTAGE OF THIS SERVICE FOR PLUG-IN-SYSTEMS ONLY

Telephone (01482) 652523 and ask for PRODUCT SUPPORT SERVICE.

HABITATION RELAY

To conform with European Safety Standards (EMC) all caravans have been equipped with a habitation relay.

This relay is actuated when the 12N/12S plugs are connected to the car's sockets and the car ignition is turned on.

The relay automatically isolates all 12V equipment within the caravan, excluding the fridge's 12V power supply, from the car.

GENERATOR GUIDELINES

- Lack of regular servicing can be the cause of most generator problems, gensets under 2kW are mainly dependent on engine speed for output frequency and voltage, poor or no servicing may cause the engine speed governor to run the genset engine too fast. Therefore frequency and output voltage can rise above the specification of the machine data plate i.e. 230V at 50Hz, this may cause damage to electrical/electronic

equipment (such as battery chargers).

- A generator should always be run for a few minutes prior to connection with the caravan or motorhome electrics, to allow it to warm up and the output to settle to a steady level.
- The AC output of generators is often derived from an AC alternator, rectified to DC then inverted back to AC. In essence this means the output sinewave may not be very smooth and may not run sophisticated electronics efficiently. Some of the new wave of gensets are more sophisticated in their production of a sinewave output and are more suited to run electronic equipment.
- If in doubt consult your genset dealer or manufacturer for advice.

ALARM MODULE - IDM 2000

Important

This handbook should be read through carefully before any attempt is made to install and use the system. For ease of understanding it is suggested that this handbook is read whilst viewing the keypad. Your alarm system, when new, contains the manufacturers code 1234. For security reasons this should be changed as soon as practical. (See 'Changing the Personal Code').

Factory Settings

Entry Delay	-	0:00 (0 secs)
Exit Delay	-	0:20 (20 secs)
Siren On Time	-	1:00 (1 minute)
Manufacturers Personal Code	-	1234

Changing the Personal Code

1. Press "F", press "1".
2. Enter the current code. (1234 if new).
3. Enter desired 4 digit code.
4. Press "F".
5. This operation can be cancelled at any time before step 4 by pressing "C".

Changing the Entry Delay Time

1. Press "F", press "0".
2. Enter your personal code.
3. Enter the new entry delay as 3 digits, i.e. 10 seconds is entered 010.
4. Press "F".
5. This operation can be cancelled at any time before step 3 by pressing "C".

Note: The Entry Delay Time must be as short as possible to prevent compromising security.

Changing the Exit Delay Time

1. Press "F", press "2".
2. Enter your personal code.
3. Enter the new exit delay as 3 digits, i.e. 20 seconds is entered 020, 1 minute is 100. (Please note the maximum time allowed is 4 minutes i.e. 400).
4. Press "F".
5. This operation can be cancelled at any time before step 3 by pressing "C".

Changing the Siren-on Time

1. Press "F", press "3".
2. Enter your personal code.
3. Enter the preferred time as 3 digits, i.e. 2 minutes is entered 200. (Please note the maximum time allowed is 4 minutes, i.e. 400).
4. Press "F".
5. This operation can be cancelled at any time before step 3 by pressing "C".

Setting up the Tilt Sensor

The tilt sensor is not adjustable and requires the caravan to be reasonably level. If the Tilt Sensor is active, one of the Tilt Sensor Indicators will illuminate on the keypad. Adjust the level of the van until the light goes off.



Electrics

Arming the System

If you are in the PIR's sight, then it is possible that when arming the system, any movement detected by the PIR will deselect the PIR channel. To avoid deselecting the PIR accidentally please ensure that you remain perfectly still when arming the system. This is very important when the keypad is sited within the PIR coverage area.

1. Enter the personal code, the indicators for all available sensors will light (IF a sensor indicator fails to light, see "TROUBLESHOOTING").
2. To Disable any sensors not required, press the relevant key, i.e. 1 for PIR, 2 for tilt, 3 for tow sensor. Repeated pressing will select (light comes on) and disable (light goes off) the relevant sensor.
3. Press "F". The exit delay will begin, 1 pulse per second.
4. 2 short bursts on the siren will be heard at the end of the exit delay. This confirms the system is armed.
5. This operation can be cancelled at any time before step 4 by pressing "C".

Disarming the System

1. Enter your personal code. (This is the only way to disarm the system).
2. If the system has been inactive all indicators will flash twice on the keypad.

3. If a sensor has been activated then the corresponding light on the keypad will flash five times. However, if the system had been continuously active for 20 minutes or more (and subsequently reset) there will be a random flashing of indicators proceeding the display of the sensor(s) responsible.

Note: When the siren is active there is no limit on key entries. When the siren is inactive a maximum of 16 key entries are allowed. If 16 key entries are exceeded then the system will not accept any more entries until the siren is activated.

Memory Recall

This enables the user to tell if any sensors were active during the previous armed state.

1. Press "F", press "5", watch the indicators.
2. If all indicators flash twice the system has been quiet.
3. If any indicator flashes 5 times, the corresponding sensor has been active.
4. A random flashing of indicators followed by 5 flashes for sensor(s) means that the system has had to reset (i.e. disarm itself) due to the siren being active for 20 minutes.

Testing

A time limit of 2 minutes is imposed when in the test modes described. After this time the system will return to standby. This is to preserve battery power.

Checking the Battery Life

Battery Life (between recharges) is eight months maximum. NEVER allow the battery to completely discharge. Regular battery life checks are strongly recommended.

1. Press "F", press "4".
2. A number of pulses will be heard; 1 pulse = 1 month, 3 pulses = 3 months etc up to a maximum of 8 pulses. If, however, a random flashing of indicators occurs, this indicates that the battery is in need of immediate charging.
3. If the battery is low, connect the battery charger via the socket on the main control box. This will be located under the front offside bed-box. Battery charging should be complete within 24 hours (for a fully discharged battery).

Please note

- i) avoid charging battery while the system is armed.
- ii) reading the battery status whilst charging the battery will give a false indication of battery life, please wait 15 minutes after charging battery before taking a reading.

Testing the PIR

1. Press "F", press "6".
2. Walk in front of the PIR. The light on the keypad marked PIR will illuminate five times, and give an audible signal.

Testing the Siren

1. Press "F", press "7".
2. The siren will sound. Press "C" to stop the siren.

Testing the Tow Sensor

The towing vehicle must be connected to the caravan via the 12S plug before this test can be carried out. This sequence also assumes that the towing vehicle is correctly wired.

1. Press "F", press "9".
2. The "FNC" light on the keypad will stay on.
3. Disconnect the car from the caravan. The siren will emit a short burst followed by five flashes on the keypad sensor indicator, and give an audible signal.

Testing the Tilt Sensor

1. Press "F", press "9".
2. Adjust the level or move the caravan until one of the Tilt Sensor Indicators on the keypad illuminates and gives an audible signal.
3. Press "C".

Troubleshooting

1. When attempting to arm, on entering the personal code, sensor lights do not illuminate - The code entered is incorrect, or all sensors are active. Check the tow vehicle is attached, that there is no-one in the PIR's field of vision, connections to the PIR are good and that the caravan is level.
2. The tilt sensor light does not illuminate on arming - The tilt sensor is active. (Press "C" to cancel then refer to section 'Setting up the Tilt Sensor').
3. The tow sensor light does not illuminate on arming - The 12S (grey) socket on the towing vehicle must be correctly wired. Assuming this is the case then the vehicle may have been disconnected from the caravan (e.g. when on site).
4. The PIR sensor light does not illuminate on arming - Ensure no-one is in the PIR's field of view, including the person who is arming the system. Move everyone outside the PIR's field of view and press "1". If the PIR indicator still does not light then check PIR connections.
5. On disarming the system the sensor indicators do not light - An incorrect personal code has been entered.
6. If you are unable to resolve your problem please contact Plug-In-Systems Product Support Department; Tel: 01482 659309.

Clearing the System back to Manufacturers Settings

If for any reason you wish to set the IDM2000 back to its factory settings then the following procedure should be used:

1. Press "F", keep finger on the "F" key until 5 bursts are heard from the keypad buzzer. The IDM2000 has now reverted to factory settings.

This can only be done when the system is disarmed.

The Noise Pollution Act

If the alarm is activated continuously for 20 minutes, the system will shut down. This effectively disarms the system. This is a requirement of the Noise Pollution Act.

Plug-In-Systems reserve the right to change product specification at any time without prior notice.



Electrics

SPECIFICATION

Mains Input 230 volts +/- 10% ~ ac

Frequency 50Hz

Output voltage 13.8 volts DC

Output current 12 amps (max)

Battery

recommended Re-chargeable lead-acid 12 volt battery, 6 cells, leisure type, 44 ampere-hours minimum

Dimensions

Height 193mm

Width 102mm

Depth 210mm (max)

Weight 2.28Kg

PRODUCT SUPPORT

Plug-In-Systems Ltd offer the customer an On-Site Service, available for both Warranty and Non-Warranty repairs (on the CEC and Plug-In-Systems range of equipment only). If you would like to take advantage of this service then please ring Plug-In-Systems (direct) on:

HULL (01482) 659309
and ask for PRODUCT SUPPORT

12 VOLT ELECTRICAL SUPPLY

If your car is fitted with the appropriate relay, please note the following points:

1. The caravan battery will be charged by the car charging system independently of the distribution panel.
2. If the caravan battery level is "low", power for the caravan 12 volt system can be obtained from the car battery, by connecting the 12S (grey) plug to the car, and setting the distribution panel selector switch to "car". This will draw power from the car battery and care should be taken not to reduce the level of the car battery so low that the car engine cannot be started. (The battery level indicator in the caravan distribution panel will show the condition of the car battery in these circumstances).
3. When the car and caravan are connected through the 12N and 12S plugs and the car engine is running, 12 volt power will be supplied to the refrigerator, provided the refrigerator selector switch is set to the 12v position, regardless of the position of the distribution panel selector switch.
4. If an extension lead from the 12S socket on a towing vehicle to the 7-core connecting cable is used while a caravan is parked on a caravan pitch, its length should be kept to a minimum and not exceed 5 metres. The minimum cross sectional area of the supply and return leads in the extension cable should be 2.5mm².

WIRING OF 12S SOCKET TO TOWING VEHICLE

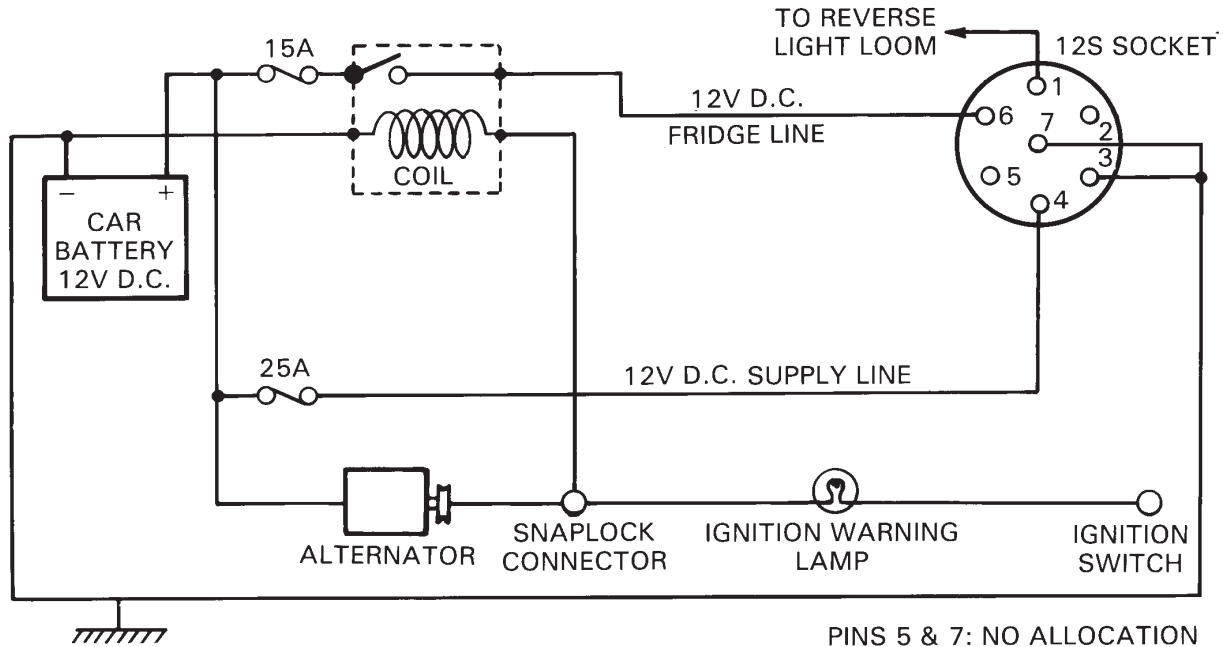

Note:

If using a combination relay, ensure the supply fuse is the correct amperage. A lower rating will 'blow' causing the fridge, if switched on, to be connected directly to the caravan battery. While towing, the caravan battery will be discharged instead of being charged.





FITTED EQUIPMENT

Whale Water Pump	54
Shurflo Water Pump	54
Truma Ultra-Store	54
Truma S3000P, S3000A Space Heaters	57
Truma Ultraheat for S3002	59
ALDE Heating System	60
TP5 Electronic Programmable Room Thermostat	67
Refrigerator	69
Model RM4270	69
Model RM4271	70
Model RM4501	71
Model RM6270, RM6271 & RM6291	72
Fridge Use and Maintenance	73
Travel Catch	76
Stoves Hobs, Grills & Ovens	76
The Hob	77
The Grill	78
The Oven	78
Cleaning	79
Thetford Cassette Porta Potti	81
Thetford Cassette C-200 CW & C-200 CWE	84
Beds	88
Cassette Blinds & Flyscreens	91
Doorscreen	91
Roof Lights, Windows and Air Conditioning	92
Ash Framed Doors	93
Shower	93
Tables	94
Fixing of Awnings	95



Fitted Equipment

The instructions covering fitted equipment to your caravan were correct at the time of going to print. Owners handbooks are updated annually and we take great care to try and ensure their accuracy. However, the Swift Group Limited cannot accept responsibility for any changes that may be made in specification or operating instructions to the equipment described in this section after the time of going to press.

Every care is taken to ensure that the information provided in this handbook is correct and easy to understand.

Separate manufacturers' leaflets on many of the components are also included in the Owner's Pack provided with this caravan and we recommend that you compare the instructions in the handbook with the component manufacturers literature, to ensure the information provided is as accurate as possible.

If you are in any doubt as to how to operate the equipment in your caravan, please contact the component manufacturer's service department on the telephone number shown on their component leaflet. If you remain in any doubt, please contact the Swift Group Supercare customer care service department on 01482 875740.

Equipment Specification

For details on type of equipment fitted in your caravan, please refer to the Sales Brochure or Dealer.

IMPORTANT

To maximise the use and life of all fitted equipment in your caravan it is essential that any accompanying manufacturers' literature is read fully. All recommended maintenance and preparation procedures should be followed. The information provided in this handbook is only intended as a guide. If in any doubt consult your manufacturer appointed dealer, particularly before attempting to install EXTRA EQUIPMENT.

WHALE WATER PUMP (Model specific)

The Whale pump is a non self priming intermittently rated centrifugal pump which draws approximately two amperes from a 12 volt battery and therefore maximum continuous operation should not exceed 15 minutes.

The pump should not be run without water and should not be used to pump water of a temperature above 60°C.

SHURFLO WATER PUMP (Model specific)

Fresh water is supplied to the caravan by a Shurflo pump. This pump is a completely sealed unit designed for intermittent use and is self-priming.

THE TRUMA ULTRASTORE WATER HEATER

OPERATING INSTRUCTIONS

Filling the Truma Ultrastore with water

e = Lever position "Closed"

f = Lever position "Drain"

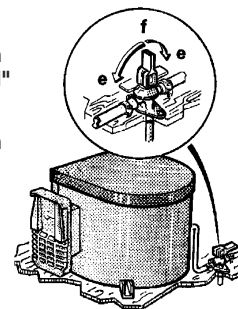

Fig. 1

1. Check that the safety/drain valve in the cold-water intake is closed. Lever should be in the horizontal position, position (e).
2. Open the hot tap in the bathroom or kitchen with pre-selecting mixing taps or single lever fittings set to hot.
3. Switch on power for water pump (main switch or pump switch). Leave the tap open to let air escape while the water heater is filling. The heater is filled when water flows out of the tap.

Residues of frozen water can prevent filling if there is a frost. The water heater

Fitted Equipment

can be defrosted by switching on the heater for a short period (max 2 mins). Frozen pipes can be defrosted by heating the room.

Gas Operating Instructions

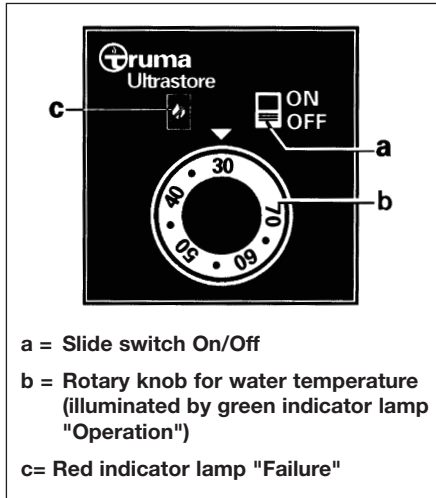

Attention: Never operate the water heater without water in it!

1. Remove cowl cover. This is the weather cover which is mounted over the exhaust on the exterior of the caravan.
2. Open gas cylinder and open quick-acting valve in the gas supply line.



3. Select required water temperature at rotary knob (b) infinitely variable from approx. 30° to 70°C.
4. Switch on water heater at the side switch (a) on the control panel, green indicator lamp "Operational" lights up.
5. If there is air in the gas supply line, it may take up to a minute before the gas is available for combustion. If the appliance switches to failure during this period, switch off the appliance, wait 5 minutes and switch on again.

Switching Off (Gas Operation)

Switch off the water heater at the side switch (a). Mount cowl cover. Drain the water if there is a risk of frost. Close quick-acting valve in the gas supply line if the appliance is

not to be used for an extended period of time and close the gas cylinder.

Red Indicator Lamp "Failure"

The red indicator lamp (c) lights if there is a failure. The reason for such an indication is, no gas available or air in the gas supply system triggering the excess temperature monitor etc. To reset the red light, switch off the appliance, wait 5 minutes and switch on again.

Note: In the event of faults always contact the Truma Service, Tel: 01283 511092.

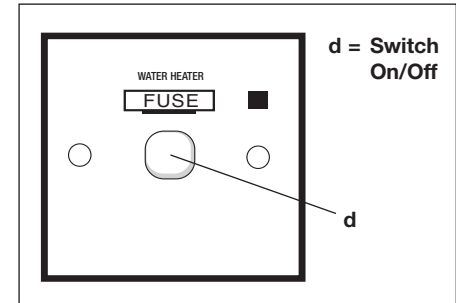

Electrical Operating Instructions

Switch the switch (d) on the fuse spur to "On". The indicator lamp indicates the electrical water-heating element is operative.

When using the vehicle switches refer to operating instructions of the vehicle manufacturer or see switch labels.



Fitted Equipment

Note: The water temperature cannot be selected, automatic temperature limitation at approx. 70°C. For a faster heating up period the appliance can be simultaneously operated with gas and electrical power.

Draining the Water Heater

e = Lever position "Closed"

f = Lever position "Drain" (see Fig.1 page 52)

1. Disconnect power for water pump (main switch or pump switch).
2. Open hot water taps in bathroom and kitchen.
3. Open safety/drain valve in vertical position, position (f).
4. The water heater is now drained directly to the outside via the safety/drain valve. Check that the water contents have been completely drained (10 litres)

Maintenance

Use wine vinegar for de-scaling the water heater, this being introduced into the appliance via the water supply. Allow the product to react and then thoroughly flush out the appliance with plenty of fresh water. To sterilise the water we recommend "Certsil-Argento". Other products, particularly those containing chlorine, are unsuitable.

Note: The water tank in the Truma Ultrastore is of high quality food-grain stainless steel.

The special equipment available, elbow water hose connections and safety/drain valve, fulfil the EC guidelines for quality in plastic parts (90/396/EEC).

In order to prevent the formation of micro-organisms, we recommend heating up the tank at regular intervals to 70°C and not using the water for drinking.

Important Operating Notes

1. If the cowl is positioned close to an opening hatch (window), keep this closed during operation. See warning plate. Always mount the cowl cover if the heater is not being used. Non-observation of this point can lead to the function of the appliance being impaired through water, dirt or insects.
2. The guarantee will be invalidated if this point is not observed. Always remove the cowl cover prior to operating the water heater!
3. If there is a defect in the electronics, return the control Printed Circuit Board well padded. If you fail to pack it correctly the guarantee will be invalidated. Only use original Truma Ultrastore control P.C.B's as spare parts.
4. If just the cold water system is being used, without water heating, the header tank becomes more vulnerable to frost damage. Accordingly the contents should be drained by operating the

safety/drain valve. This also applies when the caravan is in storage.

General Safety Notes

In the event of leaks in the gas system or if there is a smell of gas:

- Extinguish all naked flames
 - Do not smoke
 - Switch off the appliance and gas cylinder
 - Open the windows
 - Do not operate any electrical switches
 - Have the entire system checked by an expert
1. Repair jobs are only to be carried out by an expert.
 2. The following would invalidate the guarantee:
 - a. Any alteration to the appliance (including cowl)
 - b. The use of non-Truma spare parts/accessories
 - c. Non observance of the operating instructions.
 3. The operating pressure for the gas supply is 30mbar (or 28mbar butane/37mbar propane) and must correspond to the operating pressure of the appliance (see name plate).
 4. Do not operate the water heater when refuelling the vehicle and when in the garage.

Fitted Equipment

- During the initial operation of a brand new appliance (or after it has not been used for some time, a certain amount of fumes, and a slight smell, may be noticed for a short time. Remedial action is to immediately run the heater at maximum output and to ensure adequate room ventilation.
- If the burner makes an unusual noise or if the flame lifts off, it is likely that the regulator is faulty and it is essential to have it checked.

Technical Data

Water contents:	10 litres
Water pressure:	up to max. 2.8 bar
Type of gas:	Liquid Gas (propane or butane)
Operating Pressure:	30mbar (or 28mbar butane, 37mbar propane)
Rated thermal output:	1500W
Gas consumption:	120g/h
Heating time to approx. 70°C:	
Gas operation:	approx. 35 mins
Electrical operation:	approx. 70 mins
Gas and electrical operation:	approx. 20 mins
Power consumption 12 V	
Ignition:	0.17 A
Heating Up:	0.08 A
Standby:	0.04 A

Power consumption 230 V
Heating Up: (2A) 450 W
Weight (empty): 6.7 Kg

THE TRUMA S 3002 P & S 3002 AUTO SPACE HEATER

INSTRUCTIONS FOR HEATERS FITTED WITH AUTOMATIC IGNITOR OR PIEZO IGNITOR

Switching On

- Open the valve on the gas cylinder. Open quick-acting valve in gas supply line.
- Turn control knob to thermostat setting 1-10 and press it down as far as the stop. At the same time keep operating the piezo ignitor rapidly until the flame ignites.
- Keep the control knob depressed for a further 10 seconds to allow the safety pilot to operate.
- (Piezo only) Watch through the flame window for another 10 seconds to make sure that the flame does not go out through air in the supply pipe (caused by the valve being closed or changing the cylinder).

Attention: Always wait at least 2 minutes before attempting to re-ignite, otherwise there is a risk of blowbacks (misfiring). This also applies if a working heater goes out has to be re-lit.

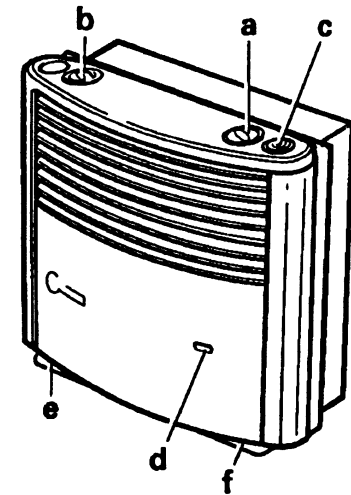

- a = Control knob**
b = Integrated control panel for Trumavent fan TEB
c = Piezo ignitor or automatic ignitor
d = Flame observation window
e = Name plate (remove casing)
f = Thermostat probe

In the case of left-handed installation, the parts are arranged on the other side.



Fitted Equipment

Automatic Ignitor

Prior to first ignition, make sure that the batteries have been inserted; observe correct fit battery cassette (see changing batteries, page 57).

Thermostat

Set the required room temperature at the control knob (numbers 1-10). For an average room temperature of approx. 22°C we recommend setting:

3-5 Without the Trumavent Fan
(switched on)

4-8 With the Trumavent Fan

Switching Off

Set control knob to "0". If turning off for a long period of time, close the quick-acting valve in the gas supply line. Close valve of gas cylinder.

Important Operating Notes

1. If the gas supply line is filled with air, it may take up to a minute before the gas becomes available for combustion. During this time depress the control knob and continuously operate the piezo ignitor until the flame ignites.
2. You will have to find out the exact thermostat setting yourself, depending on how much heat you need.

3. Repairs are only to be carried out by a competent service engineer.

Attention: A new O-ring must always be installed after dismantling the exhaust duct.

4. Any alteration to the appliance (including exhaust duct and cowl) or the use of spare parts and accessories, which are important to the function of the heater and which are not original Truma parts, as well as the non-observance of the installation and operating instructions, will lead to the cancelling of the guarantee and exclusion of liability claim.
5. During the initial operation of a brand new appliance, a certain amount of fumes and a slight smell may be noticed for a short while. Remedial action is to immediately run the heater at maximum output and to ensure adequate room ventilation.
6. In winter, before switching on the heater, remove all snow from the cowl.
7. Inspect the exhaust duct and all connections at regular intervals and always whenever there is a blowback (misfire). It is essential that the exhaust duct is installed so that it slopes upwards over its whole length and is securely fixed with several clamps. Never place any object on the exhaust duct, since this could result in damage. The exhaust

duct connection to both the heater and the cowl must be firm and well sealed. Do not operate heaters with incorrectly fitted or damaged exhaust ducts.

8. Never allow the warm air outlet on the heater to be obstructed in any way. For instance never hang washing on or in front of the heater to dry. Misusing your heater in this way could cause serious damage from overheating. Do not place flammable objects near the heater. Please follow these guidelines in the interest of your own safety.
9. If the burner makes an unusual noise or if the flame lifts off while burning, it is likely that the regulator is faulty and it is essential to have it checked.
10. Cleaning (with switched off appliance): It is recommended that at least once a year, before the heating season starts, you remove any dust that has collected on the heat exchanger base plate.

Technical Data:

Type of gas:	Liquid gas (propane/butane)
Operating pressure:	30mbar (28mbar butane, 37mbar propane)
Rated thermal output:	3400W
Gas consumption:	30-280 g/h

Fitted Equipment

Product Ident. No: CE-0085AP0325

Automatic Ignitor

Power consumption: 50 MA (ignition)
0.01 MA
(monitoring)

Operating voltage: 3V

CHANGING OF BATTERIES

Changing the Batteries on the Automatic Ignitor

Only change the batteries with the heater switched off.

Always insert new batteries at the beginning of the heating season.

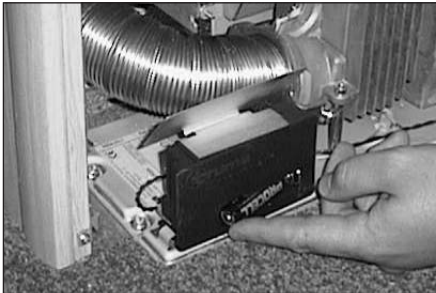

Unclip front of heater, slide up battery cover to reveal battery. Change the batteries. Observe plus/minus.

Only use temperature resistant (+70°C), leak-proof Mignon round cells (LR 6, AA, AM 3, Art. no. 30010-23600). Other batteries could lead to malfunctions!

TRUMA ULTRAHEAT ADDITIONAL ELECTRIC HEATING FOR TRUMATIC S 3002

OPERATING INSTRUCTIONS

Important: Before operating the heater for the first time it is essential to observe the operating instructions enclosed with the heater.

Switching on

Warning: Before switching on, ensure that the fuse protection for the power supply of the camp site is sufficient for the selected power setting (b) (see Technical Data).

Important: The electric feed line for the caravan must be fully unwound in the cable drum.

1. Push slide switch (b) to the required power setting.
2. Push slide switch (a) to the "ON" position.
3. Set rotary control knob (c) to the desired room temperature.

The electric heater can also be operated without the Trumavent fans.

If the heater is operated simultaneously with electricity and gas, the electrical unit will switch itself off before overheating occurs as a result of the stronger gas burner.

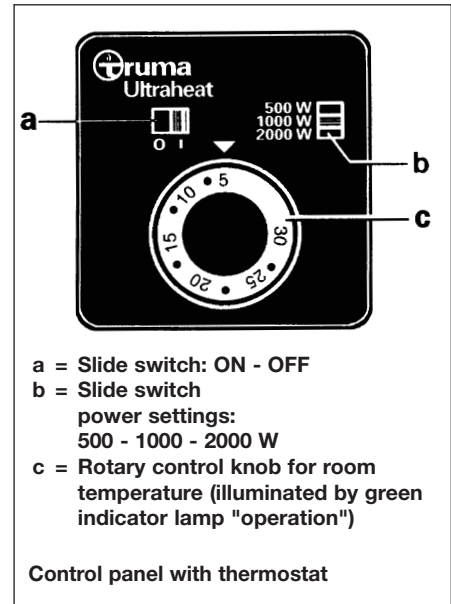

Fitted Equipment

Blown air

The air ducting outlets are generally of the butterfly type and may be opened or closed by adjusting the butterfly valves. Twisting the disc in its housing directs the flow in the direction required.

One outlet on each leg of the air ducting layout must be kept open at all times.

Switching off

Push slide switch (a) to the "OFF" position.

IMPORTANT OPERATING NOTES

1. **Repairs may only be carried out by an expert.**
2. Under no circumstances should the hot air outlet be blocked. Never hang clothes or similar in front of or on top of the heater to dry. This could cause serious damage to the heater as a result of overheating. Do not place inflammable materials near the heater! Please observe these instructions for your own safety.
3. When operating a brand new heater for the first time (or after it has been idle for a lengthy period) you may temporarily notice a slight smoke and smell. We advise running the heater at full power and thoroughly ventilating the room
4. Any modifications to the appliance or the use of spare parts and accessories important for the operation, which are not original Truma parts, or non-observance

of the instructions for installation and use will result in the guarantee becoming invalid and no liability will be assumed. Furthermore, the approval for operating the appliance will become invalid and in some countries also the approval for operating the vehicle.

TECHNICAL DATA

Power supply: 230 V ~, 50 Hz

Power consumption at power setting:
500 W: 2,2 A 1000W: 4,5 A 2000 W: 8,5 A

Weight: approx. 2 kg

ALDE HEATING SYSTEM

Please read these instructions carefully before using the boiler.

These instructions are approved for Alde Compact 3000 92X, 93X and 94X boilers fitted in caravans, motor caravans and buildings in accordance with CE no. 048 AP-0013.

A professional may only carry out installation and repairs. National regulations must be adhered to.

BOILER DESIGN

The boiler consists of three eccentrically fitted cylinders (heat exchanger, water jacket for the heating system and, outermost, water jacket for hot water). The two outer pipes, as

well as their ends and connections, are made from stainless steel, while the heat exchanger is made from aluminium.

The heat exchanger is divided into two semi-circles. The burner is located in the upper half, the combustion chamber, and the combustion gases are expelled through the lower half. The burner unit is fitted on the end of the heat exchanger. It consists of a combustion fan, burner, solenoid valve and intake/exhaust connections. One or two heating cartridges are fitted to the water jacket of the heating system. Output is 2 or 3 kW, depending on model.

DESCRIPTION OF FUNCTIONS

Using LPG

When the sliding switch on the control panel is set to LPG, the combustion fan starts. The fan creates pressure against the pressure gauge. When the fan pressure is sufficiently high, the pressure gauge signals the electronics box that the boiler can be lit. The electronics box sends ignition sparks to the spark plug at the same time as it sends electricity to the solenoid valves, which open to allow gas in. The burner ignites, and a sensor transmits a signal back to the electronics box that the boiler is lit and ignition spark stops. The burner keeps burning until the boiler thermostat or the room thermostat reaches the set temperature reading. Should the boiler go out for any

reason, the sensor is activated and the electronics box ensures that a new attempt is made to start the boiler (in about 10 seconds).

Using the heating cartridge

When the heating cartridge sliding switch is set to any of the output settings on the control panel, the 12-volt relays on the circuit board trip, allowing the 230-volt supply to reach the cartridge. The heating cartridge is controlled in the same way as the gas boiler.

IMPORTANT INFORMATION

- The LPG boiler and heating cartridge may be operated in parallel.
- The heating system may be heated up without the warm water heater being filled with fresh water.
- Always drain the warm water heater of fresh water if there is a risk of frost.
- The LPG boiler must not be operated when filling the vehicle with fuel, in a garage or elsewhere.
- The boiler must not be started if there is no glycol in the system.

THE CONTROL PANEL

The boiler is controlled using sliding switches on the control panel. The desired temperature in the vehicle is set and regulated via the thermostat on the control panel.

Control panel functions:

- A. Heating cartridge switched off.
- B. Heating cartridge switched on at 1050 W.
- C. Heating cartridge switched on at 2100 W.
- D. Heating cartridge switched on at 3150W (if the boiler is fitted with this output setting).
- E. LPG boiler switched off.
- F. LPG boiler switched on.
- G. LED indicates that the LPG boiler is in blocking mode (the burner has not ignited, or has gone out for some reason).
- H. Warm water setting. The circulation pump switched off. The heating cartridge/LPG boiler is operated by the boiler's built-in thermostat. Used when only hot water is wanted.
- I. Normal setting. The circulation pump is switched on and is controlled by the thermostat on the control panel. The operation of the heating cartridge/LPG boiler is controlled by the boiler's built-in thermostat. Used when both heating and warm water is wanted.
- J. Permanent setting. The circulation pump is switched on and runs constantly. The thermostat on the control panel controls the operation of the heating cartridge/LPG boiler. This setting is used in particular circumstances, mostly during the winter.

Provides an even flow of heat, but also reduces the hot water capacity.

- K. Knob for setting the desired room temperature.
- L. Index marking for a room temperature of approx. 22°C.

THE WARM WATER HEATER

ABOUT LPG

The properties of LPG

LPG is a petroleum product, formally known as 'liquid petroleum gas'. It is mainly made up of propane and butane gas. The advantage of propane is that it remains gaseous at temperatures as low as -40°C, while butane loses effectiveness at +10°C. For this reason, propane is used in colder countries. The cylinders contain LPG both in liquid and gaseous form. Then the cylinders are filled, the pressure turns the gas into liquid. When the cylinder valve is opened, the LPG becomes a gas again. The risk involved in using LPG is that any leaking gas may ignite and explode. Since LPG is heavier than air, any leaking gas will collect at the lowest point.

LPG contains no toxic substances but breathing in concentrated gas may have a certain anaesthetising effect, and can also result in shortness of breath and symptoms of suffocation. These symptoms quickly disappear if the sufferer breathes in ordinary



Fitted Equipment

air or oxygen. Naturally, it is inadvisable to inhale either LPG or exhaust fumes. To make it easier to detect gas leaks, a substance with a distinctly rank smell has been added.

Combustion

Complete combustion of LPG only generates carbon dioxide (CO₂) and water vapour, just like the air we exhale. A good supply of air is essential to ensure complete combustion. The centre of the flame should be blue/green. LPG is extremely environmentally compatible and does not generate any soot during complete combustion.

It can be stored in cylinders for an unlimited time period, without any deterioration of quality.

Pressure

The LPG burner usually works at a lower pressure than that in the cylinder. The most common pressure is a low pressure (0-50 mbar), which is created by allowing the gas to pass through a reduction valve. There is also intermediate pressure (50 mbar-2.0 bar) and, finally, high pressure (over 2.0 bar), which is unreduced pressure mainly used in camping equipment. Low pressure and intermediate pressure are always reduced pressure.

FAULT FINDING

The boiler does not start

1. No LPG?
2. Is the main tap fully open?
3. If the boiler has not been operated for some time, or if the gas cylinder has been changed, it may take longer than normal to light the boiler.
4. Check that the boiler is connected to the electricity supply (> 11 V).
5. Check that the fuse (T) for the boiler is intact.
6. Check whether the overheating protection has been tripped by unscrewing the black plastic cap (U) and pressing the reset button (V).

NB! If the overheating protection has been tripped it cannot be reset until the boiler has cooled down by 10-20°C. Before restarting the boiler, check that it has been properly bled.

7. Check whether the red LED on the control panel has gone out. If not, switch off the boiler. Wait 30 seconds and then try restarting it.
8. Check that the boiler's electrical connections are properly attached.
9. If none of these help, please contact a service company.

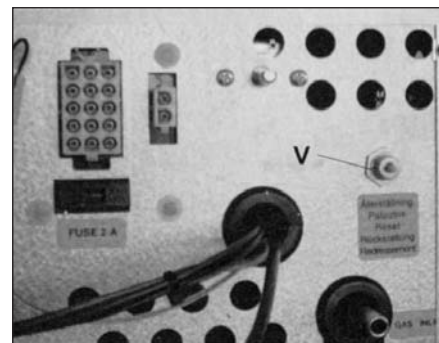
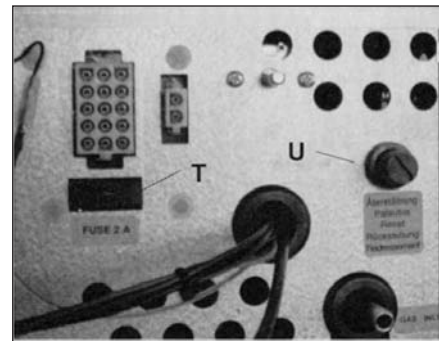

The heating cartridge is not working

1. Check that there is an electricity supply (230 V~) to the heating cartridge.

2. Check that the relays fitted to the boiler come on (a slight click can be heard from the relays when the heating cartridge is switched on at the control panel).
3. Check whether the overheating protection has been tripped by unscrewing the black plastic cap (U) and pressing the reset button (V).
4. If none of these work, please contact a service company.

GUARANTEE

Alde's guarantee is valid for one year from the date of delivery and only covers materials or manufacturing faults, provided that the directions for installation and use have been followed. The guarantee does not cover frost damage.

NB! Only Alde original parts should be used as replacement parts.

The boiler is fitted with a built-in warm water heater with a volume of approx. 8.5 litres fresh water. The warm water heater can produce around 12 litres of 40°C water per half-hour (at a cold water temperature of 10°C). If the heating cartridge is used instead of gas for heating the boiler, the capacity is slightly reduced.

Always rinse out the heater before it is used, particularly if it has not been in operation for some time.

NB! The hot water is not intended for drinking or cooking. When the heater is in continuous use, it should be emptied approx. once a month, to ensure that a new air cushion is formed in the heater. The air cushion is essential for absorbing pressure surges in the heater.

For emptying specially adapted boilers, as well as any other freshwater systems in the vehicle, please refer to the manufacturer's instructions.

NB! The warm water heater should always be drained of fresh water when there is a risk of frost and when the caravan is not in use. The guarantee does not cover frost damage.

Draining the heater using the combined safety/drain valve:

1. Switch off the freshwater pump.
2. Open all water taps.
3. Then open the safety/drain valve by raising the yellow lever (M) to a vertical position.
4. The heater will now drain directly below the vehicle through the safety/drain valve hose. Check that all the water is emptied out (about 7-10 litres). Leave the valve in the open position until the next time the heater is used.

NB! Check that the automatic check valve (N) is open and is allowing air to enter the heater when it is being drained, and that the hose (O) is not blocked.

Fitted Equipment

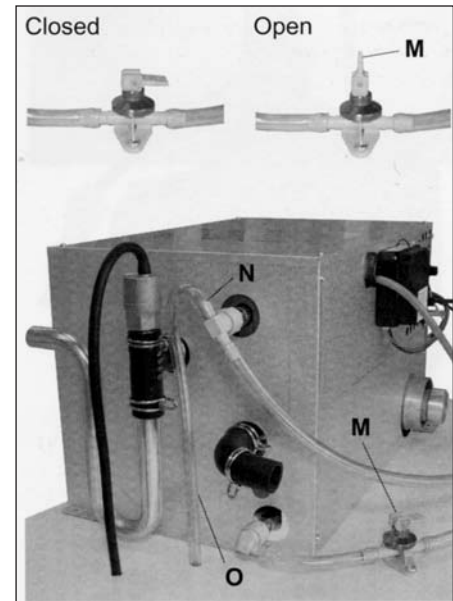

THE HEATING CARTRIDGE

All compact boilers are fitted with one or two 230 V heating cartridges with a maximum output of either 2100 or 3150 W. Select the heating cartridge output by sliding the switch on the control panel to the desired output position. Always check that the input fuse of the vehicle has the correct amperage in relation to the selected output.



Fitted Equipment

1050 W requires a 6-amp fuse.

2100 W requires a 10-amp fuse.

3150 W requires a 16-amp fuse.

THE CIRCULATION PUMP

A 12 V circulation pump is fitted in the expansion tank. It circulates the heated glycol fluid in the heating system. Use the sliding switch on the control panel to start the circulation pump. The room thermostat on the control panel controls the circulation pump, i.e. switches it on or off according to the amount of heat required. The circulation pump may also be operated continuously. (See the control panel section.)

Please note that continuous operation of the 12 V circulation pump considerably reduces the service life of the motor.

SYSTEM TEMPERATURE

The boiler is set to a system temperature of 80°C, i.e. the temperature of the glycol fluid as it circulates in the heating system. The system temperature may be reduced when required, i.e. if the warm water becomes too hot.

Lowering the system temperature

Turn the spindle (Q) anti-clockwise. A quarter turn represents a temperature reduction of 10°C. To increase the system

temperature, turn the axle clockwise until it reaches its maximum position and cannot be turned any further. The system temperature is then reset to 80°C.

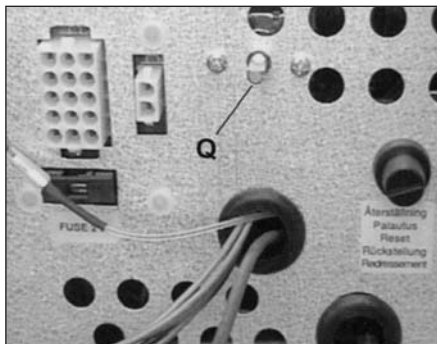

AIR CIRCULATION

In order to achieve the best possible result from the principle of waterborne heat, it is important to allow air to circulate freely under bunks, and behind backrests and wall-mounted cabinets. If the vehicle has a fitted carpet, ensure that the carpet does not obstruct the air supply to the radiators. It is just as important that cushions or blankets do no interrupt the flow of air behind backrests and wall cabinets.

MAINTAINING THE HEATING SYSTEM

Winter camping

While camping during the winter, ensure that the flue is kept clear of snow and ice since the inlet air to the LPG boiler enters through the flue. Do not start the LPG boiler until the flue is completely free of snow. A flue extension (part no. 300 320) for fitting on the roof is recommended for winter camping.

The LPG system

A professional, who will ensure that there are no leaks from connections or hoses, should check the LPG system regularly. LPG hoses should be changed every second year, since their propensity to dry out and crack will eventually result in leaks.

To increase safety, we recommend fitting an Alde leak gauge, type 4071, as close as possible to the pressure reduction valve.

The heating system

Regularly check the heating system's fluid level in the expansion tank. The level should be about 1cm above the minimum indicator in a cold tank.

The heating system should be filled with a mixture of water and glycol. For preference, use high quality ready-mixed glycol (with inhibitor) intended for use in aluminium heating systems. If using concentrated glycol, the mixture should consist of 60% water and 40% glycol. If the heating system

Fitted Equipment

will be exposed to temperatures below - 25°C, the glycol content must be increased, but not to more than 50%.

Any vessels used for the liquid must be spotlessly clean, and the pipes in the heating system must be free of contamination. This will prevent the growth of bacterial in the system.

The glycol mixture should be checked before topping up with new liquid. This will ensure that the concentration of glycol in the mixture is not too high.

If the fluid level in the expansion tank falls for reasons other than evaporation, please check all joints, drain cocks and bleeder screws to ensure that they are not leaking. If the glycol-water mixture leaks out, rinse with water and wipe up. New allow the heating system to stand empty of glycol.

FILLING THE SYSTEM WITH GLYCOL FLUID

NB! Any vessels used for the liquid must be spotlessly clean, and the pipes in the heating system must be free of contamination. This will prevent the growth of bacterial in the system.

The system is filled through the expansion tank, either manually or using the Alde filling pump which both tops up and bleeds the system. For manual filling, unfasten the circulation pump nut (R) and life the pump (S) out of the tank. Slowly pour the glycol

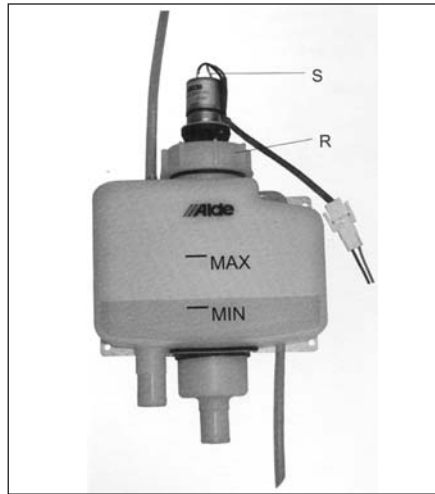

mixture into the tank. Bleed the system. Top up with more liquid if the level has fallen after bleeding. Bleed a newly filled system regularly during the first days the heating system is in operation.

BLEEDING THE SYSTEM

Depending on how the pipes have been fitted, air pockets may form when the system is filled with glycol fluid. A sign that there is air trapped in the system is that the heat released into the pipes only extends a metre or so from the boiler even though the

circulation pump is operating. In newly filled systems, small air bubbles can form in the expansion tank, creating a murmuring sound. If the circulation pump is stopped for a few seconds, the bubbles will disappear.

Bleeding

If a bleeder screw is fitted to the outgoing pipe on the rear of the boiler, open this bleeder screw and leave it open until it starts to discharge water. If the boiler is fitted with an automatic bleeder, there is no need to bleed it manually.

Start the LPG boiler. The circulation pump should be switched off. Open the remaining bleeder screws in the system (please refer to the instruction manual of the vehicle for their locations). Leave the bleeder screws open until they start discharging fluid. Start the circulation pump and let it run for a while. Check that the pipes and radiators around the vehicle are heating up. If they still fail to heat up, try the following:

Single-axle caravans: Stop the circulation pump. Using the jockey wheel, lower the front of the caravan as far as possible so that the rear is tilted upwards. Leave it in this position for a few minutes to allow the air to travel upwards in the system. Open the bleeder screw at the highest point. Leave it open until it discharges glycol fluid.

Using the jockey wheel, raise the front of the caravan as far as possible and repeat the



Fitted Equipment

procedure in this position. Then position the caravan horizontally and start the circulation pump. Check that the pipes and radiators around the vehicle are heating up.

Motor caravan or twin-axle caravan: The easiest way to bleed the heating system is to place the vehicle on a sloping surface or to raise one end of the vehicle using a jack. Bleed the system as described above.

SETTINGS FOR OPERATION OF THE HEATING SYSTEM AND WARM WATER HEATER

For more information on the settings on the panel, please refer to the 'Control Panel' section.

WARM WATER ONLY WITH 230 V HEATING CARTRIDGE

1. Switch the circulation pump switch to position (H).
2. Switch the LPG switch to position (E).
3. Switch the electric cartridge switch to position (B).

(When the system is being used for warm water only, the electronics limit output to 1kW, irrespective of the output actually selected).

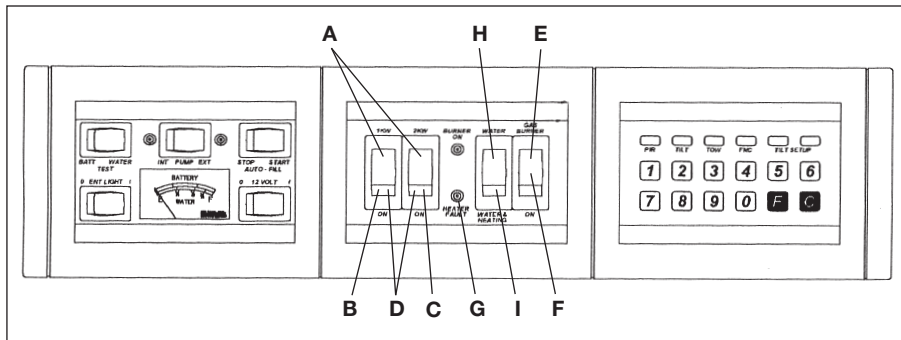

WARM WATER ONLY WITH LPG BOILER

1. Open the LPG shut-off valve.
2. Switch the circulation pump switch to position (H).
3. Switch the LPG switch to position (F).
4. Switch the heating cartridge switch to position (A).

HEATING AND WARM WATER WITH 230 V HEATING CARTRIDGE

1. Switch the circulation pump switch to position (I).
2. Switch the LPG switch to position (E).
3. Switch the heating cartridge switch to the desired output position (B, C or D).

In the illustration, an output of 2100 W has been selected.

4. Adjust the temperature to the desired level (5-30°C) using the TPS control thermostat (K).

HEATING AND WARM WATER WITH LPG BOILER

1. Open the LPG shut-off valve.
2. Switch the circulation pump switch to position (I).
3. Switch the LPG switch to position (F).
4. Switch the heating cartridge switch to position (A).
5. Adjust the temperature to the desired level (5-30°C) using the TPS control thermostat (K).

HEATING AND WARM WATER WITH BOTH 230 V HEATING CARTRIDGE AND LPG BOILER

(Use only when electricity or gas alone is not sufficient)

1. Open the LPG shut-off valve.
2. Switch the circulation pump switch to position (I).
3. Switch the LPG switch to position (F).
4. Switch the heating cartridge switch to the desired output position (B, C or D).

In the illustration, an output of 2100 W has been selected.

5. Adjust the temperature to the desired level (5-30°C) using the TPS control thermostat (K).

SETTINGS FOR OPERATION OF THE HEATING SYSTEM AND WARM WATER HEATER

For more information on the settings on the panel, please refer to the 'Control Panel' section.

SWITCHING OFF THE LPG BOILER, HEATING CARTRIDGE AND CIRCULATION PUMP

1. Switch all three switches on the control panel to the O-position (H, E, A).
2. Close the main switch to the heating system if the vehicle will not be used.

If the main switch is not closed, the boiler will remain in the stand-by position and use a small amount of electricity.

3. Close the LPG shut-off valve.

IF THE RED LED-LIGHT COMES ON

The boiler is fitted with an ionised flame sensor. This means that if the flame goes out for some reason, the electronics will attempt to re-light it. If the flame is not re-lit within ten seconds, the solenoid valve switches off the gas supply, the electronics are blocked and the red LED (G) on the control panel is switched on. The electronics must be reset before the boiler can be started.

Resetting from the blocked position:

1. Switch the LPG switch to position (E). The LED (G) will go out.
2. Wait approx. 30 seconds while the electronics reset the block.
3. Switch the LPG switch to position (F). The electronics will once again attempt to start the boiler.

TP5 ELECTRONIC PROGRAMMABLE ROOM THERMOSTAT

FEATURES

- Controls central heating systems to provide different room temperatures up to 6 times a day
- The TP5 has one programme for Monday to Friday, with a different programme for Saturday and Sunday.
- Setting the TP5 to the lowest temperature will effectively switch off the heating, whilst providing frost protection for the controlled area*

RESET

The unit may be reset to 12:00PM (MO) and the factory set programme by pressing and holding down the four buttons, temperature ▲ and ▼, time + and -, until the display goes blank.

SETTING THE CLOCK

Press the PROGRAMME button once; the colon is no longer flashing. Use the + and - button to set the time. Hold down a button to change the time quickly; press and release a button to change the time by one minute. When the time and AM or PM are correct, press the PROGRAMME button to start the clock, now only the day and the colon are on display. Use + or - button to select the



Fitted Equipment

correct day. Press PROGRAMME to display the first setting.

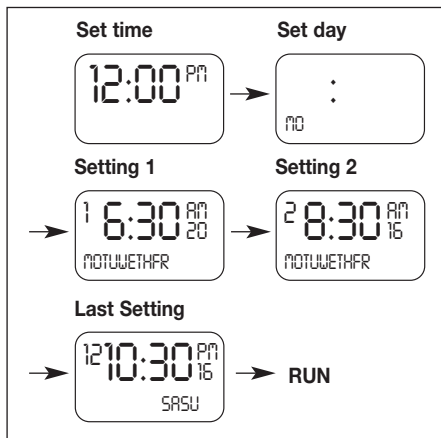

REVIEWING THE EXISTING SETTINGS AND PROGRAMME YOUR OWN

Now each press of the PROGRAMME button shows, in, turn, the set times, (twelve with the TP5), together with their associated control temperatures. The time and/or temperature of each setting may be altered to your own requirements using the + and - (time) and ▲ and ▼ (temperature) buttons.

LIMITS OF ADJUSTMENT FOR TIME SETTINGS

Time setting 1 can be at any time of the day or night, but would normally be in the morning.

Each of the time settings 2 to 6 can be at any time between the preceding setting and 1.59am. Time settings 2 to 5 can be set later than the next setting, but doing this changes the next setting as well..... E.g.changing setting 2 in any of the above to 3.00pm would also change setting 3 and 4 to 3.00pm.

This feature prevents times being set out of sequence. If you wish to return to the pre-set programme reset the unit as described above.

EVERYDAY OPERATION

When all twelve time/temperature settings have been checked and/or altered, ensure the Programmable Room Thermostat is in the RUN mode with the colon blinking before sliding the cover shut.

MANUAL OVERRIDE

If you wish to temporarily change the control temperature from the automatic setting, there is no need to re-programme the thermostats; just press the up or down button until the temperature you want is displayed. An up or down arrow will

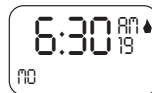

appear in the display to remind you that you have over-ridden the programmed temperature. The unit will revert to programmed temperature at the start of the next programmed event.

CONSTANT LOW TEMPERATURE CONTROL

To set the thermostat to control at its low setting (5°C to 16°C depending on model) for 24 hours a day press both t and u buttons at the same time. The display will show the blinking colon, the low setting and the snowflake symbol. To return to the automatic programme press the t and u buttons together again.

BATTERY REPLACEMENT

When the batteries approach the end of their life, a battery symbol blinks in the display. Have the new batteries unwrapped and ready, slide the battery cover fully off to the left, remove the old batteries and insert the new ones WITHIN ONE MINUTE.

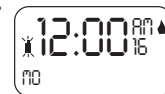

Fitted Equipment

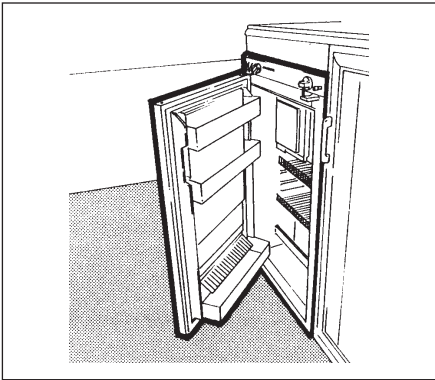

REFRIGERATOR

When using your refrigerator for the first time, it is advisable to wash the interior and its accessories.

When the caravan is on tow, the refrigerator should be operated electrically, i.e. from the 12V battery in the towing vehicle, and not by means of bottled gas.

CONTROLS

The refrigerator can be run on either 230V, 12V or LP gas. Changing between these modes of operation is carried out by means of the controls shown on the relevant control panel.

Caution!
Only use one source of energy at a time.

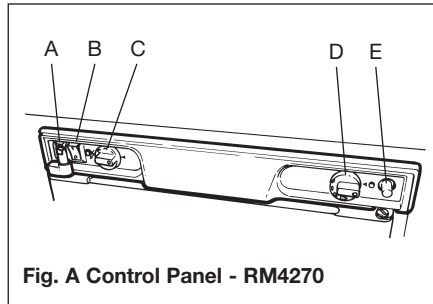

Fig. A Control Panel - RM4270

MODEL RM4270

Bottled Gas Operation - Lighting the burner

1. Open the shut-off valve of the gas bottle (check that there is enough gas). Open any on-board shut-off valve.
2. Check that the switches for mains and 12V are off.
3. Depress and turn on the gas control safety device knob (D) to the large flame symbol.
4. Depress the gas control safety device knob (D) and hold it down while depressing the piezo-electric igniter button (E) rapidly 3 or 4 times in quick succession.

5. Check the flame viewer (located bottom left of refrigerator) to see if the flame is alight.
6. Keep the safety device control knob depressed for a further 15-30 seconds.
7. Release the safety device control knob and again check to see that the flame is alight.
8. To terminate gas operation, turn knob (D) to 'O'.

ELECTRIC OPERATION

230V Operation

1. Turn off gas or 12V operation when applicable.
2. Turn the knob (C) of the thermostat to its highest (coldest) position.
3. Set switch (B) to position I.

12V Operation

There is no thermostat control on 12V operation.

Only operate your refrigerator on 12V when the engine of your vehicle is running.

Note: Before operating the refrigerator on 12V it should be pre-cooled, together with its contents, by running it on bottled gas or 230V for a few hours before changing over to 12V and starting on a journey.



Fitted Equipment

1. If applicable, turn off the gas operation.
2. Set the 230V rocker switch (B) to 'O' and the 12V rocker switch (A) to I.

Regulating the temperature

Once the refrigerator has been started it will take a few hours to become cold.

On 230V operation the refrigerator is controlled by a thermostat and the thermostat knob (C) should be set at 3. If a colder temperature is required, set the thermostat to a higher number and vice versa.

On LP gas operation the refrigerator temperature is regulated by the gas control knob (D). If the ambient temperature is above 25°C and/or the door of the refrigerator is frequently opened, the knob should be set in the 'max' position. Below 25°C, the knob should be set at 'mid' and below 10°C at 'min' to avoid temperatures below freezing in the main compartment.

MODEL RM4271

Two rocker switches are used to select the electric power supply, one for 230V (B) and one for 12V (A) (See Fig. B).

Refrigerator temperature is controlled by a thermostat knob (C) when the refrigerator runs on 230V.

The gas supply is turned ON/OFF by means of the knob (D). When lighting the gas, the

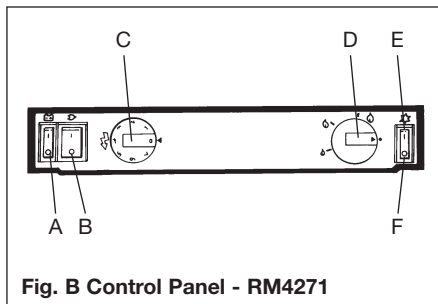

Fig. B Control Panel - RM4271

knob must be pressed as explained in LP Gas Operation.

Refrigerator temperature is controlled by a thermostat (E) when the refrigerator runs on LP gas. Please note that the thermostat has no 'OFF' position.

The gas flame is electronically lit, monitored and re-lit if necessary. For this, the toggle switch (F) should be 'ON' during gas operation.

STARTING THE REFRIGERATOR

LP Gas Operation

Before you start gas operation:

1. Open the shut-off valve of the gas bottle (check that there is enough gas). Open any on-board shut-off valve.
2. Check that the switches for mains and 12V operation are off.

3. Turn on gas supply by pressing knob (D) and turning it to the flame position.
4. Set the thermostat knob (E) to the highest setting.
5. Turn on switch (F). A light in the switch should now start to flash, indicating that sparks are being generated at the burner.
6. Press button (D). This opens the flame failure device and allows gas to flow to the burner.
7. When the flame ignites, the sparking stops automatically and the switch stops flashing.
8. Keep the knob (D) pressed for a further 10 to 15 seconds to activate the flame failure device, then release it.

230V Operation

1. Turn off gas or 12V operation when applicable.
2. Turn the knob (C) of the thermostat to its highest (coldest) position.
3. Set switch (B) to position I. The switch will light up green when the power supply is connected.

12V Operation

Only operate your refrigerator on 12V when the engine of your vehicle is running. Install through a relay, otherwise your battery will soon be discharged.

Fitted Equipment

Note: Before operating the refrigerator on 12V, it should be pre-cooled, together with its contents, by running it on bottled gas or 230V for a few hours before changing over to 12V and starting on a journey.

1. If applicable turn off the gas operation.
2. Set the 12V rocker switch (A) to I. The switch will light up red when the power supply is connected.

REGULATING THE TEMPERATURE

The position numbers refer to Fig. B.

Once the refrigerator has been started it will take a few hours to become cold.

On 230V operation the refrigerator is controlled by a thermostat and the thermostat knob (C) should be set at 3-5. If a lower (colder) temperature is desired, set the thermostat to a higher figure.

On LP gas operation the refrigerator temperature is regulated by the gas thermostat knob (E), which should be set at 3-5. If a lower (colder) temperature is desired, set the thermostat at a higher figure.

On 12V operation the refrigerator works continuously.

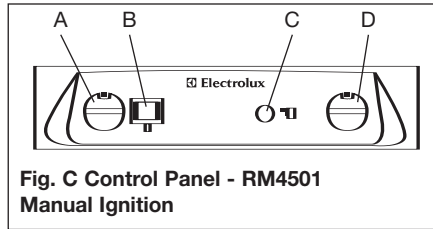

**Fig. C Control Panel - RM4501
Manual Ignition**

MODEL RM4501

The refrigerator can be run on 230V, 12 V or LP gas. Changing between these modes of operation is carried out by means of the control buttons positioned as shown in fig. C.

The energy selection (A) can be set at either "AC" (230V), "DC" (12 V), "GAS" (LP gas) or "OFF".

An indicator lamp (B) at the control panel flashes when the automatic ignitor attempts to light the burner. Otherwise this lamp is off.

The refrigerator is fitted with a safety device, which automatically shuts off the supply of gas if the flame goes out. The safety device can be opened manually by depressing knob (C).

The refrigerator temperature is controlled by a thermostat (D) when the refrigerator runs on 230V and LP gas. Please note that the thermostat has no "off" position when the refrigerator runs on LP gas.

STARTING THE REFRIGERATOR

LP Gas operation

After initial installation, servicing, or changing gas cylinders etc., the gas pipes may contain some air, which should be allowed to escape by briefly turning on the refrigerator or other appliances. This will ensure that the flame lights immediately.

To start gas operation:

1. Open the shut off valve of the gas bottle (check that there is enough gas). Open any on-board shut-off valve.
2. Set the thermostat knob (D) to the highest setting.
3. Turn the energy selector (A) to position "GAS". A ticking sound will be heard and the lamp (B) will start flashing.
4. Press the button (C). This opens the flame failure device and allows gas to flow to the burner.
5. When the flame lights, the sparking stops automatically and the lamp stops flashing.
6. Keep the knob (C) depressed for another 10-15 seconds to activate the flame failure device, then release it.

If the lamp starts flashing again, repeat steps 4-6.

To terminate gas operation, turn the knob (A) to "OFF" position.



Fitted Equipment

230V operation

Before taking the refrigerator into operation, check that the voltage stated on the data plate is the same as the main voltage in use.

- Turn the thermostat knob (D) to its highest (coldest) position.
- Set the energy selector (A) to position "AC"

12 V operation

Only operate your refrigerator on 12 V when the engine of the vehicle is running - otherwise your battery will soon be discharged.

- Set the energy selector (A) to position "DC"

REGULATING THE TEMPERATURE

It will take a few hours for the refrigerator to reach normal operating temperature. We therefore suggest you start it well in advance of a trip and if possible store it with pre-cooled foodstuffs.

On 230V operation and LP gas operation the refrigerator is controlled by a thermostat and the thermostat knob (D) should be set at 3-5. If a lower (colder) temperature is desired, set the thermostat to a higher figure.

On 12 V operation the refrigerator works continuously.

MODEL RM6270, RM6271 AND RM6291

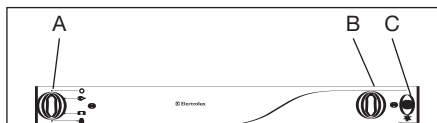

**Fig. D Control Panel - RM6270
Manual Ignition**

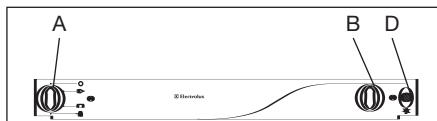

**Fig. E Control Panel - RM6271 & RM6291
Automatic Ignition**

The refrigerator is equipped to operate off mains power, 12V/24V or liquid gas. The desired option is selected by means of energy selector switch (A). Energy selector switch (A) has four settings: AC mains power, DC (12V/24V), gas (liquid gas), O off.

Refrigerator temperature is controlled by a thermostat (B) when the fridge runs on gas and mains electric. No thermostat control is available on 12V/24V operation.

(C) is the manual ignition button (Piezo ignition).

(D) is the automatic ignition indicator.

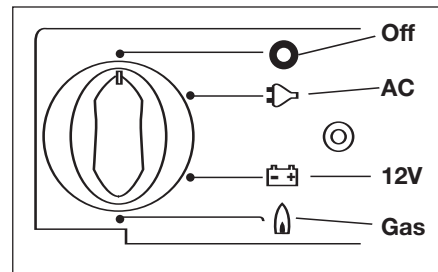

STARTING THE REFRIGERATOR

LP Gas Operation

Open the shut off valve of the gas bottle (check there is enough gas). Open any on board shut off valve.

For models with manual ignition

1. Set the energy selector switch (A) to gas 
2. Press and hold rotary thermostat switch (B)
3. Activate Piezo ignition (C) several times at intervals of 1-2 seconds.
4. Check the inspection glass to see if there is a flame (the inspection glass is inside the refrigerator at the bottom left).
5. Keep rotary switch (B) depressed for another 10-15 seconds, then release.
6. Check the inspection glass, to see that the flame is burning.
7. Repeat the entire procedure if the flame has gone out.

- Adjust the temperature in the main refrigerator compartment using rotary switch (B)

For models with automatic ignition

- Set the energy selector switch (A) to gas 
- Press and hold rotary thermostat switch (B)
- The ignition process is activated automatically, accompanied by a ticking sound; the indicator lamp (D) will flash. Upon successful ignition, the sound and flashing will stop.
- Keep rotary switch (B) depressed for another 10-15 seconds, then release.
- If there is an inspection glass, check to see that the flame is burning.
- If the flame goes out the ignition system will repeat the ignition process automatically.
- Adjust the temperature in the main refrigerator compartment using rotary switch (B)

Note:

The fridge must exclusively be operated using liquid gas (propane and butane)

All refrigerators are equipped with automatic flame protection, which automatically cuts off the gas supply 30 seconds after the flame goes out.

When using for the first time or after changing the gas cylinder, the gas pipes may contain air. By means of brief operation of the refrigerator and any other gas appliance (eg cooker) air is removed from the gas pipes. The gas will then ignite without delay.

Main 230V Operation

Note:

The operation may only be selected where the supply voltage of the connection for the power supply corresponds to the value specific on the data plate. Any difference in values may result in damage to the appliance.

- Set the energy selector switch (A) to 
- Use rotary switch (B) to regulate the temperature in the main refrigerator compartment.

12V/24V Operation

Only operate your refrigerator on 12V/24V when the engine of your vehicle is running. Install through a relay otherwise your battery will soon be discharged.

Note:

Before operating the refrigerator on 12V/24V, it should be pre-cooled, together with its contents, by running it on gas or 230V for a few hours before changing over to 12V/24V for your journey.

Fitted Equipment

- Set the energy selector switch (A) to 

The refrigerator will run continuously without thermostatic control.

FRIDGE USE AND MAINTENANCE

WINTER OPERATION

Please check that the ventilation grilles or the flue outlet are not blocked by snow, leaves etc.

Some caravans with outside ventilation may have so called winter covers that protect the cooling unit against cold air (ask your dealer). The covers may be fitted when the outside temperature is below approx. 10°C and should be fitted when the temperature is below freezing point.

We suggest that you fit the winter covers when the vehicle is laid up during winter months.

FOOD STORAGE

Always keep food in closed containers. Never put hot food in the refrigerator; allow it to cool first.

Never keep items in the refrigerator which might give off flammable gases.

The frozen food compartment is intended for the storage of frozen food and for making ice. It is not suitable for freezing items of food.



Fitted Equipment

Never put bottles or cans of fizzy drinks in the frozen food storage compartment as they may burst when freezing.

Most kinds of frozen food can be stored in the frozen food compartment for about a month. This period of time may vary, however, it is important to follow the instructions on the individual packages.

ICE MAKING

It is practical to make ice during the night - when the refrigerator is less demanded and the cooling unit has more reserves. Fill the ice tray to just below the brim with drinking water and place it on the freezer shelf.

It is possible to make ice faster by turning the control knob temporarily to its highest value but do not forget to turn it back to its regular setting afterwards as the refrigerator might otherwise become too cold.

DEFROSTING

Frost will gradually accumulate on the refrigerator surfaces. It must not be allowed to grow too thick as it acts as an insulator and adversely affects refrigerator performance. Check the formation of frost regularly every week and when it gets about 3mm thick, defrost the refrigerator.

To defrost the refrigerator, turn it off and remove the ice trays and all food items. Leave the cabinet and freezer doors open.

Do not try to accelerate defrosting by using any kind of heating appliance as this might damage the plastic surfaces of the refrigerator. Neither should any sharp objects be used to scrape off the ice.

The defrost water runs from a collector channel to a receptacle at the rear of the refrigerator where it normally evaporates.

Heavy frost build up on the freezer plate and the cooling fins, and a lot of defrost water:

Move the plastic drain tube into a watertight bucket or container. (Access through the lower ventilation grill on the outside of the vehicle). As the frost melts, the water will flow into the container. Replace the drain tube to its original position after defrosting.

Defrost water in the freezer compartment should be mopped up with a cloth.

When the ice has melted, wipe the refrigerator dry and restart it. Place the food items back inside but wait until the refrigerator is cold before making ice cubes.

CLEANING THE REFRIGERATOR

Clean the inside of the refrigerator regularly to keep it fresh and hygienic.

Soak a cloth in a solution consisting of a teaspoon of bicarbonate of soda to half a litre of warm water. Wring out the cloth and use it to clean the interior of the refrigerator and its fittings.

Never use detergents, scouring powder, strongly scented products or wax polish to clean the interior of the refrigerator as they may damage the surfaces and leave a strong odour.

The exterior of the refrigerator should be wiped clean now and then, using a damp cloth and a small quantity of detergent, but not the door gasket which should only be cleaned with soap and water and then thoroughly dried.

The cooling unit behind the refrigerator should be cleaned with a brush from time to time, but make sure that the refrigerator is switched off when doing this.

TURNING OFF THE REFRIGERATOR

If the refrigerator is not to be used for some time:

1. Turn all controls "OFF".
2. Shut off any on-board valve in the gas line to the refrigerator.
3. Empty the refrigerator. Defrost and clean it as described earlier. Leave the doors of the refrigerator and frozen food compartment ajar.
4. When the vehicle is laid up for a long period of time (e.g. during the winter months), we suggest fitting the winter covers on to the grills.

Fitted Equipment

IF THE REFRIGERATOR FAILS TO WORK

Check the following points before calling a service technician:

1. That the "STARTING THE REFRIGERATOR" instructions have been followed.
2. The refrigerator is level.
3. If it is possible to start the refrigerator on any of the connected sources of energy.
4. If the refrigerator fails to work on gas, check:
 - That the gas bottle is not empty
 - That the LP gas valves are open.
5. If the refrigerator fails to work on 12 V, check:
 - That the 12 V supply is connected to the refrigerator.
 - That the fuse on the 12 V supply is intact.
 - That the battery is not run down.
6. If the refrigerator fails to work on 230V, check:
 - That the 230V supply is connected to the refrigerator.
 - That the fuse is intact.

If the refrigerator is not cooling sufficiently, the reason may be:

1. Inadequate ventilation of the cooling unit due to the intake and/or exhaust air vents being partly or completely blocked.

2. The evaporator is frosted up.
3. Incorrect thermostat settings.
4. Incorrect gas pressure - please check the pressure regulator on the gas container.
5. The ambient temperature is too high.
6. Too much food is loaded at one time.
7. The door is not properly closed or the magnetic sealing strip is defective.

If the refrigerator still does not work properly, call a service technician.

The sealed cooling system must not be opened, since it contains corroding chemicals under high pressure.

MAINTENANCE

Always turn to a qualified service technician who is familiar with LP gas systems and refrigerators.

We recommend that a service technician check the refrigerator once a year.

- Check all connections in the LP gas system for gas leaks. Connections can be tested for leaks using a soap solution. Do not use a naked flame! If there is any suspicion of damage, call for a service technician
- The ventilation openings are unobstructed.

- The Instruction Manual is available.
- Check that the burner is clean and free from combustible material.

SOME USEFUL HINTS

Make sure that:

- The refrigerator is not operating on 12 V when the vehicle is parked, otherwise you will drain the car battery in a short time.
- Defrosting is carried out periodically.
- The refrigerator is clean and dry with the door left open when it is not to be used for some time.
- Liquids or items with a strong odour are well packed.
- The ventilation openings are unobstructed.
- The doors are secured by means of both travel catches when the caravan is on the move.

SERVICE AND SPARE PARTS

Service and spare parts are obtainable from your dealer of Electrolux - consult the telephone directory.



Fitted Equipment

TRAVEL CATCH

All models are fitted with a travel catch (type A or B depending on model) to keep the refrigerator door securely closed when the vehicle is on the move.

Remember always to push the catch down, so that its lower end fully engages the plastic bush in the top of the door, before moving off.

FURTHER DETAILS

Consult the accompanying literature to obtain the full benefit of your Electrolux Refrigerator.

In the event of failure, contact Electrolux Service. Details of which can be found in your Yellow Pages Directory.

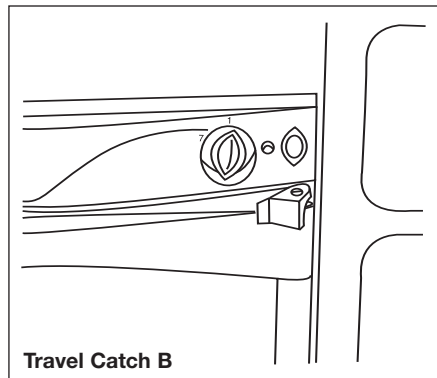
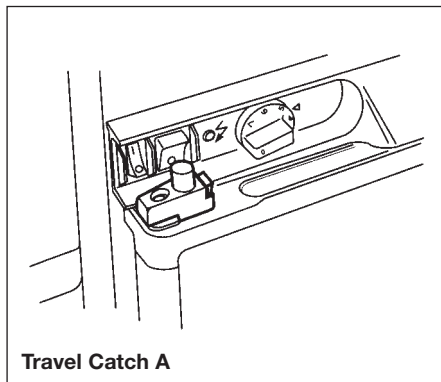

PLEASE READ THE MANUFACTURERS INSTRUCTIONS BEFORE OPERATING THE APPLIANCE

WARNING: When you are cooking it is essential to provide additional ventilation such as opening windows.

WARNING: When using cooking or heating appliances, surfaces and handles may become hot. Care should be taken and if necessary hand protection used.

STOVES HOBS, GRILLS AND OVENS

BURNER IGNITION

The hotplate lid must be open for the hotplate, grill or oven burners to ignite.

The ignition should not be operated for more than 15 seconds. If, after 15 seconds the burner has not lit, stop operating the ignition, open the compartment door and wait at least 1 minute before attempting to ignite the burner.

In the event of the burner flames being accidentally extinguished, turn off the burner control and do not attempt to re-light the burner for at least 1 minute.

SPARE PARTS

When ordering spare parts, please give the following information so the appliance can be correctly identified:

Fitted Equipment

1. The name of the appliance from the fascia, and its colour.
2. The model number and the serial number of the appliance (from the data badge).

BE SAFE - NOT SORRY

Warning: Good ventilation is essential to the continuing safe operation of all gas appliances. Do not allow any ventilation openings to become accidentally or deliberately blocked.

Keep all flammable materials (such as curtains, furnishings, towels and clothing) away from the appliance.

Parts of the appliance may be hot during or immediately after use. Allow sufficient time for the appliance to cool after switching off.

When opening the appliance door, take care to avoid skin contact with any steam which may escape from the cooking.

Do not use aluminium foil to cover the grill pan, or put items wrapped in foil under the grill as this can create a fire hazard.

Do not use the oven with the door inner glass panel removed (glass oven doors only).

If the cooker has a storage compartment below the oven, this should only be used to store oven furniture. Do not store any flammable materials in this compartment.

When cooking with fat or oil, never leave unattended.

Turn pan handles inwards so they are out of reach of children and cannot be caught accidentally.

Glass lids may shatter when heated, turn off all burners before shutting the lid.

Models without ignition button: For safety reasons, we recommend the use of a hand held spark ignitor or gas lighter to ignite the burner, rather than a match or taper, which could allow burning debris to fall behind the appliance.

When you have finished cooking, check that all controls are in the off position.

THE HOB

Caution:

- Do not use foil on the hob, as it creates a fire hazard
- Glass lids may shatter when heated, turn off all burners before shutting the lid
- Note: When positioning the pan support, ensure that the fingers are central to the burners (Fig 1).

Always use the most appropriate size of burner for the pan you wish to use. Use pans with a flat base of minimum 100mm/4 ins diameter, and maximum 200mm/8 ins diameter, which are stable in use. Avoid odd or misshapen pans as these may cause instability.

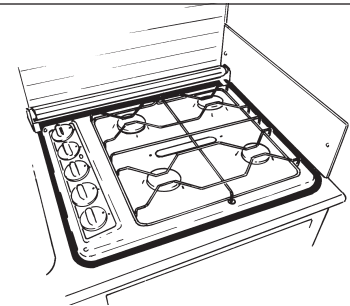

Stoves Hob

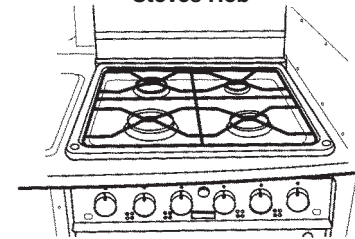

Stoves Hob

Important: Any spillage of liquid should be cleaned away immediately to reduce the risk of fluid entering the appliance.

Ignition - Push in the control knob and turn anticlockwise to the large flame symbol. Keep the knob depressed, and press the ignition button (if fitted), or use a hand held spark ignitor or gas lighter. The knob must be held in for 15-20 seconds before releasing.



Fitted Equipment

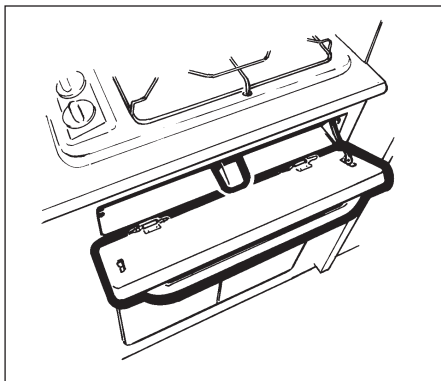

THE GRILL

- Note: The door must be open when the grill is used.
- Caution: When the grill is being used, accessible parts may be hot; young children should be kept away.
- Never cover the grill pan or grid with cooking foil, or allow fat to build up in the grill pan as this creates a fire hazard.
- Keep all flammable material away from the appliance.

To light the grill

Push in the control knob and turn anticlockwise to the large flame symbol. Keep the knob depressed, and press the

ignition button (if fitted), or use a hand held spark ignitor or gas lighter. The knob must be held in for 15-20 seconds before releasing.

Detachable grill handle (if supplied)

Place the handle (shield uppermost) over the edge of the grill pan at the recess and slide along to position centrally between the two locator bumps. To remove the handle, place the grill pan down, and lift the handle slightly as you slide it along the recess.

Using the grill

Push in the grill pan until it locates centrally under the grill burner

There are three different grilling positions as the trivet can be inverted to give a high or low position or it may be removed.

1. The high trivet position is suitable for toasting bread.
2. The low trivet position is suitable for grilling all types of meat.
3. With the trivet removed the food is placed directly on the base of the grill pan, eg; when cooking dishes such as whole fish.

Always preheat the grill for 3 minutes for best results.

When you have finished grilling, check the control knob is in the off position

THE OVEN

Caution: When you are cooking, keep children away from the vicinity of the oven.

- **Important:** A safety device stops the ignition being used when the oven door is closed.
- Do not use foil on the oven shelves as this creates a fire hazard, and can hinder circulation of heat.
- Keep all flammable material away from the appliance.

To light the oven

1. Open the oven door and turn the control knob anticlockwise to the required gas mark. Push in and hold in the control knob, and either press the ignition button (if fitted) or use a hand held spark ignitor or gas lighter.
2. Once the burner has lit, close the oven door and hold the knob in for 15-20 seconds.
3. If the flame goes out, the flame sensing device cuts off the gas supply to the burner. To light the oven again, wait for 3 minutes then repeat the above procedure.

To turn off - Push in the control knob and turn clockwise.

Fitted Equipment

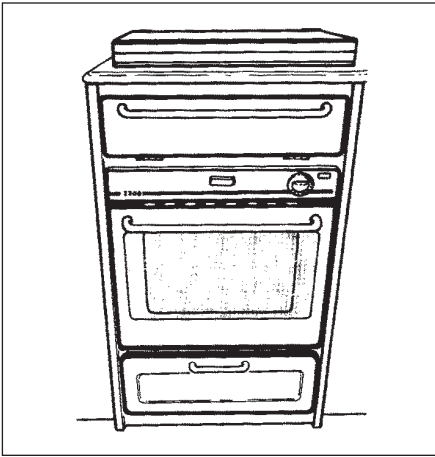

Preheating

The oven must be preheated for 10 minutes when reheating frozen or chilled food, and we recommend preheating for all yeast mixtures, batters, soufflés and whisked sponges.

Using the oven

The shelf positions in the oven can be altered. If you prefer darker cooked results, cook on a higher shelf. For paler results use a lower shelf.

The cake tray and roasting tin that are supplied with this appliance are the largest which can be used for good results and even baking. Extra shelves, tins or trays can be

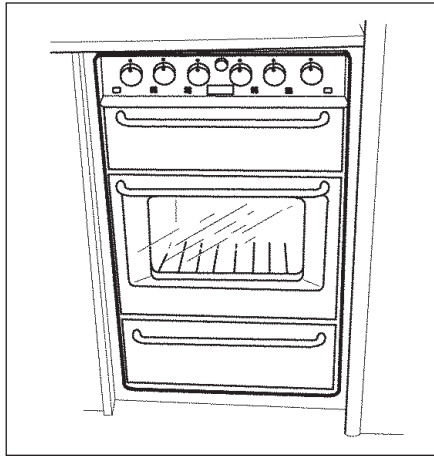

ordered from your supplier.

Place food items on the tray and position the tray on the centre of the shelf, leaving one clear shelf position between shelves to allow for circulation of air.

CLEANING

Caution: Any cleaning agent used incorrectly may damage the appliance.

Always let the appliance cool before cleaning.

Some cooking operations generate a considerable amount of grease. This combined with spillage can become a hazard

if allowed to accumulate on the appliance through lack of cleaning. In extreme cases this may amount to misuse of the appliance and could invalidate your guarantee.

Do not use caustic pastes, abrasive cleaning powders, coarse wire wool or any hard implements as they will damage the surfaces.

All parts of the appliance can be safely cleaned with a cloth wrung out in hot soapy water.

Burner caps and heads

Important: Allow burners to cool before cleaning.

Caution: Hotplate burners can be damaged by soaking, automatic dishwashers (or dishwasher powders/liquids), caustic pastes, hard implements, coarse wire wool and abrasive cleaning pastes.

For the burners to work safely, the slots in the burner head, where the flames burn, need to be kept clear of deposit. Clean with a nylon brush, rinse and dry thoroughly.

Clean with a mild cream cleaner eg; Jif, or use a moist soapy Brillo pad.

Note: Fixed burners (if fitted): Some versions incorporate fixed burners. These burners are secured to the hob with 2 screws. Fixed burners must be cleaned whilst in position. Make sure that the gap between the burner and the hotplate does not become blocked with grease.



Fitted Equipment

Glass parts (if fitted)

DOOR PANELS, FACIA PANEL,
HOTPLATE LID

Do not use abrasive cleaners or polishes. Use a mild cream cleaner, eg; Jif. Rinse thoroughly and dry with a soft cloth.

The inner door glass panel can be removed for cleaning; open the door wide, hold the bottom and top edges and slide out. When replacing the glass panel, hold it level and straight with the grooves in the door trims before sliding back in.

Painted, plastic and gold coloured parts

DOOR FRAME & HANDLES, CONTROL
KNOBS

Only use a clean cloth wrung out in hot soapy water.

Vitreous enamel parts

GRILL PAN, HEATGUARD, OVEN/GRILL
COMPARTMENT(S), HOB SPILLAGE WELL,
PAN SUPPORTS

Use a mild cream cleaner. Look for one that has the Vitreous Enamel Council's recommendation seal, eg; Jif.

Chrome plated parts (Fig 1)

GRILL GRID, SHELVES, SHELF RUNNERS

Do not use abrasives or polishes. Use a moist soap pad, eg; Brillo. Shelf runners can

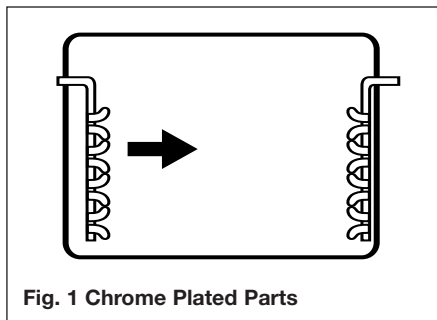

Fig. 1 Chrome Plated Parts

be removed for cleaning. Grasp the runners and slide out of the hanging holes as shown in fig 1.

Stainless steel surfaces (stainless steel models only)

Only use a clean cloth wrung out in hot soapy water, and dry with a soft cloth. Do not use undiluted bleach or any products containing chlorides as they can permanently damage the steel.

Some foods are corrosive, eg; vinegar, fruit juices and salt, and they can mark or damage stainless steel if they are left on the surface for any length of time. Wipe any spillage immediately.

Sharp objects can mark the surface of stainless steel but will become less noticeable with time.

THETFORD CASSETTE PORTA POTTI

INTRODUCTION

The Cassette Porta Potti is constructed of high quality plastics for durability and has a high gloss finish that is easy to clean and maintain. The unit consists of two sections, a permanently installed toilet system and a slide out waste holding tank — CASSETTE.

The toilet section includes a seat and cover, flush and valve blade opener knob, toilet tissue compartment and holder, waste level indicator, built-in toilet fluid storage compartment, a drip tray — a drain tube assembly and a fresh water tank.

The unique Cassette section is located underneath the toilet and is removed for emptying from outside the caravan through an access door. A rotating pour-out spout, automatic holding tank vent, air release valve, valve blade, carrying handles and hand grips are incorporated into the Cassette.

PREPARING FOR USE

1. Open access door on the side of the caravan and swing out fresh water fill funnel.
2. Fill fresh water tank using a hose or jerrycan until water funnel level reaches neck. Tank capacity is 15 litres. Aqua Rinse may be added to improve cleaning of bowl and flushing of unit.

3. Replace cap. Swing water fill funnel inward until it touches side of water tank.
Note: 150ml of water will remain in fill bottle when fresh water tank is empty.
4. Next add Aqua Kem to Cassette for controlling odours. Depress retaining clip.
5. Remove cassette by pulling straight out. When Cassette hits stop, tilt downward slightly and remove (stop for safety when Cassette is full).
6. Position tank vertical and swivel pour out spout upward.
7. Remove cap. Remove deodorant from storage compartment. Add 100ml of Aqua Kem or 120ml of Aqua Kem Bio through pour out spout. Add small amount of water through spout to cover tank bottom. Replace cap and return pour out spout to its original stored position.

Note: As an alternative deodorant can be added to Cassette through the valve blade opening. Hotter weather or longer retention time may require addition of more Aqua Kem.

CAUTION: Do not add Aqua Kem Concentrate or Aqua Kem Bio directly into toilet bowl while Cassette tank valve blade is closed. Pressure due to heat and altitude change can build up in the Cassette tank causing bowl contents to splash upward upon opening the valve blade, if opened too fast. Before each use, open and shut the Cassette valve blade to vent the tank

Fitted Equipment

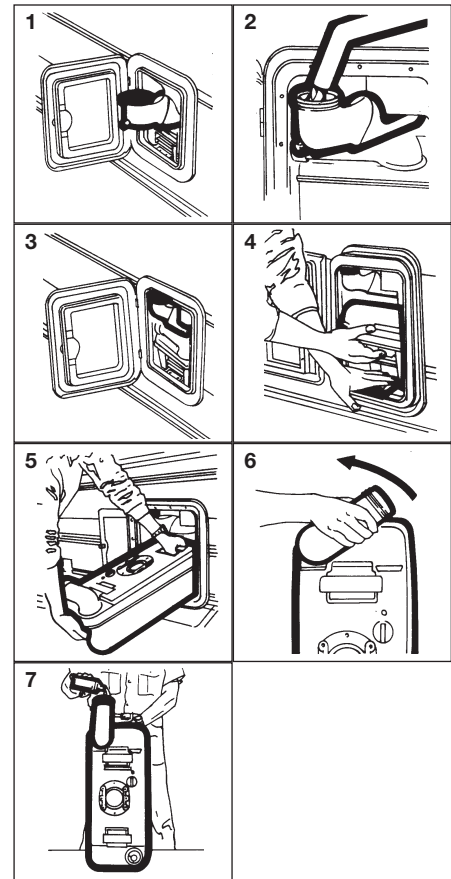

Fitted Equipment

- Slide the Cassette, pour out spout facing outside into the caravan through access door. Never force insertion or removal of the Cassette tank, damage to system can occur.
- Make sure the Cassette is secured by the retaining clip. Close and lock access door.

OPERATION

Flushing (Electric Models)

- Before using the toilet we advise to add some water to the bowl by pressing down the flush knob. This avoids marking the bowl. Water will stop flowing when knob is released.
- To flush after use, press the flush knob down while turning in an anti-clockwise direction. The turning motion opens the valve blade, emptying the toilet bowl. This procedure results in the best bowl rinse and most efficient use of water. After flushing, turn the knob in a clockwise direction to close the valve blade. The toilet can also be used with valve blade open, which allows the waste to go directly into the holding tank.

Flushing (Manual Models)

- Before using the toilet, we advise you to add some water to the bowl by turning the flush knob in clockwise direction. When flush knob is released it will turn automatically back.

- To flush after use, turn the valve knob in anti-clockwise direction and turn the flush knob. This procedure results in the best bowl rinse and most efficient use of water.

TOILET TISSUE

- Toilet tissue is stored in the specially designed storage compartment that helps keep tissue clean and dry (electric models only). Tissue can also be suspended on a tissue holder using the special wall mount bracket, if desired.
- To replace tissue, remove tissue holder from compartment by pulling up on tissue cover. Hold bottom of tissue holder in one hand and cover in the other, and turn in opposite directions until you hear a click. Pull apart. Place tissue on holder, insert prongs of cover into holder. Hold cover and holder and twist in opposite direction until locked. Aqua Soft toilet tissue is recommended for best results.

Emptying the Cassette

The Cassette capacity is 20 litres and should be emptied when the waste level gauge indicator goes from green to full red.

The gauge does not begin to move from green to red until the tank is over half full.

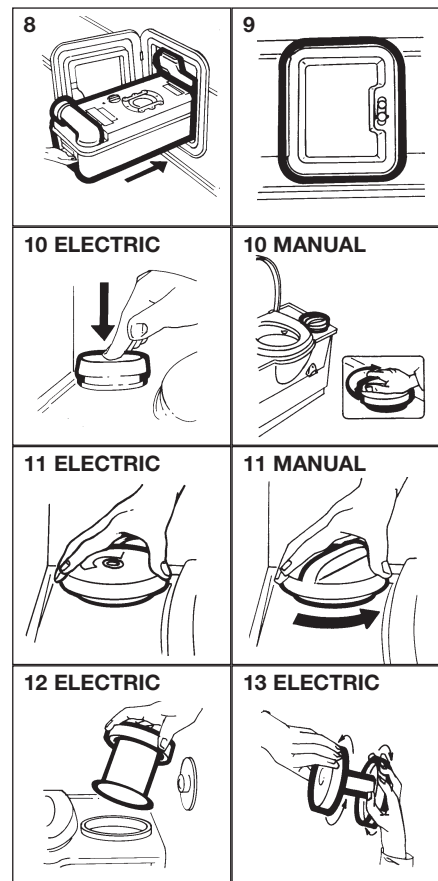

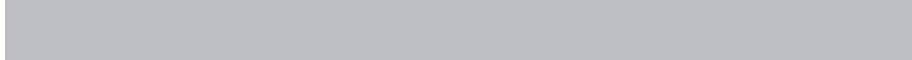

Caution: Do not allow Cassette to become overfilled, see Trouble Shooting section for emergency emptying procedure.

The holding tank features a unique sliding cover (1) which guarantees optimal hygiene. The sliding cover moves automatically when the holding tank is inserted. When holding tank is removed, the cover automatically assumes its correct position. To clean the holding tank, you may remove the cover manually by sliding it towards the pour-out spout.

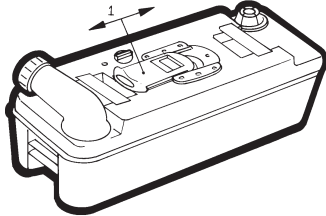

To empty Cassette be sure that the valve blade is in the closed position.

14. Open the access door on side of caravan.
Depress the retainer clip, pull Cassette until stop, tilt and remove Cassette.
15. Carry the Cassette using the lower carrying handle, pour out spout up, to a normal household type toilet or other authorised disposal point. Set Cassette in vertical position on the ground and rotate pour out spout upward.

16. Remove spout cap. Grasp unit by upper carrying handle nearest to pour out spout. Place other hand on upper rear grip so that the air relief valve button can be depressed with thumb while emptying, to ensure smooth outflow of tank contents. When empty, rinse tank and valve blade with water.

Note: Depress air release valve button only when pour out spout is pointed downwards.

17. After preparing for use, slide the Cassette into the caravan. Check to make sure that the retaining clip secures the tank in a locked position. The pour out spout end of the tank should be visible through the access door opening. Add water to the fresh water tank as outlined in "Preparing for Use" section. Close and lock access door.

CLEANING AND MAINTENANCE

No routine maintenance is required on the Thetford Cassette Porta Potti. The use of Aqua Rinse helps to clean and protect the toilet bowl, valve blade and seals during flushing. Do not use strong household detergents or cleaners with chlorine, solvents or acid contents, as they will damage valve seals.

Empty Cassette and rinse tank with clear water. Use a mild soap to clean toilet bowl, seat and cover, as well as exterior of toilet



Fitted Equipment

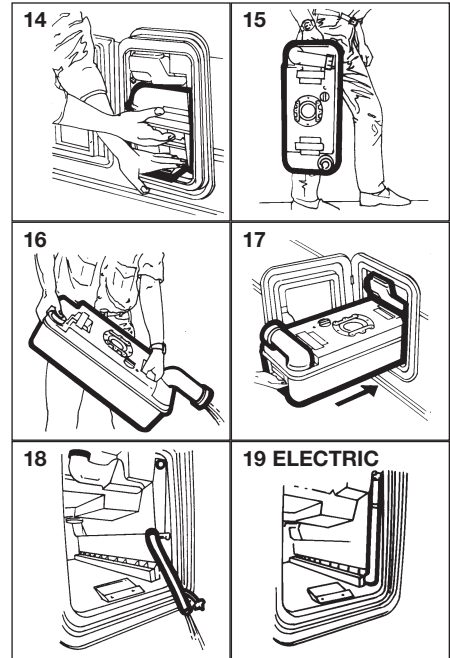

unit and Cassette. Replace tank inside caravan.

Note: Pour-out spout and vent plug can be removed. Seals should be greased if necessary with acid-free vaseline.



Fitted Equipment

THETFORD CASSETTE C-200 CW (Manual) and C-200 CWE (Electric)

FEATURES

1. Removable seat and cover.
2. Rotatable bowl.
3. Valve blade handle: opens and closes valve blade.
4. Flush-handle activates the flush by lifting and pushing down the handle.
- 4a **C-200 CWE.** Flush button: activates flush.
- 4b **C-200 CWE.** Valve blade buttons: open and close valve blade electronically.
5. Power-supply for the waste-level indicator: two batteries, type: Penlite 1,5V AA alkaline.
6. Waste-level indicator: indicates when holding tank requires emptying.
7. Rotating pour-out spout: makes emptying holding tank easy and convenient.
8. Upper carrying handle
9. Automatic holding tank vent: vents the holding tank when the tank is inserted in the toilet. This prevents under- or overpressure in the holding tank.
10. Valve blade opener.
11. Sliding cover: closes automatically when holding tank is taken out. Guarantees optimal hygiene.
12. Valve-blade
13. Vent button: vents the holding tank to avoid splashing while emptying.
14. Hand grip
15. Access door
16. Waterfill door

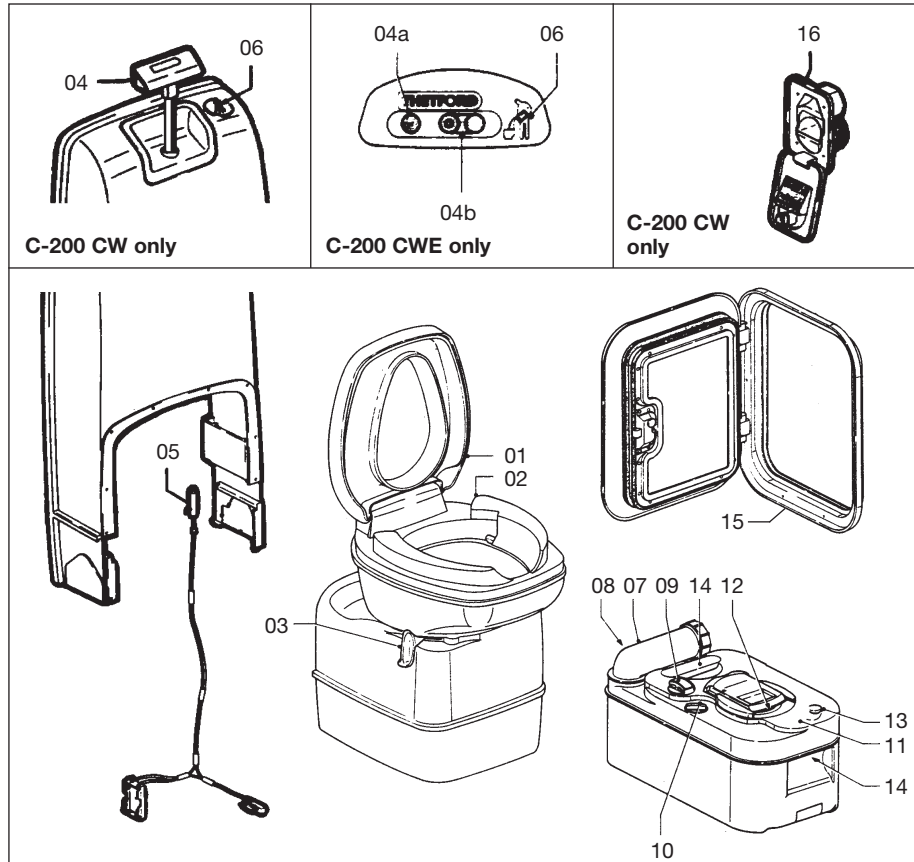

Fitted Equipment

CASSETTE C-200 CW AND C-200 CWE

The toilet section of the C-200 includes a rotatable bowl, removable seat and cover, a console with a flush handle/flush buttons, a built in flush-watertank and a waste level warning indicator. Underneath the bowl, the valve blade handle is located.

PREPARING FOR USE

1. Open access door pull retaining clip upwards (fig. 1).
2. Remove holding tank by pulling straight out. When holding tank hits the stop, tilt front end downwards slightly and remove (fig. 2).
3. Position tank vertically and swivel pour-out spout upwards (fig. 3).
4. Remove the cap of the pour-out spout. Add required quantity of toilet fluid through pour-out spout then add approx. 2 litres of water through the spout to cover holding tank bottom. Replace cap and return pour-out spout to its original stored position (fig. 4).

Note: Warmer weather or longer intervals between emptying the waste tank may require additional toilet fluid. Use only Thetford toilet fluid to achieve the best results.

Caution: Never add toilet fluid directly into toilet bowl.

5. Slide the holding tank into position through access door (fig. 5).
6. Make sure the holding tank is secured by the retaining clip (fig. 6).
7. Open the waterfill door and add 50 ml of Aqua Rinse. Aqua Rinse results in a better flush and improves the hygiene of the toilet. Then fill the watertank with fresh water using a jerrycan or a hose. Tank capacity is 7 litres (fig. 7).

OPERATION

8. Turn the bowl in the most comfortable position (fig. 8).
9. **C-200 CW only:** Before using the toilet it is recommended to flush some water into the bowl by lifting and pressing down the flush handle (fig. 9).
- 9a. **C-200 CWE only:** Before using the toilet it is recommended to flush some water into the bowl by pressing and releasing the flush button (fig. 9a).

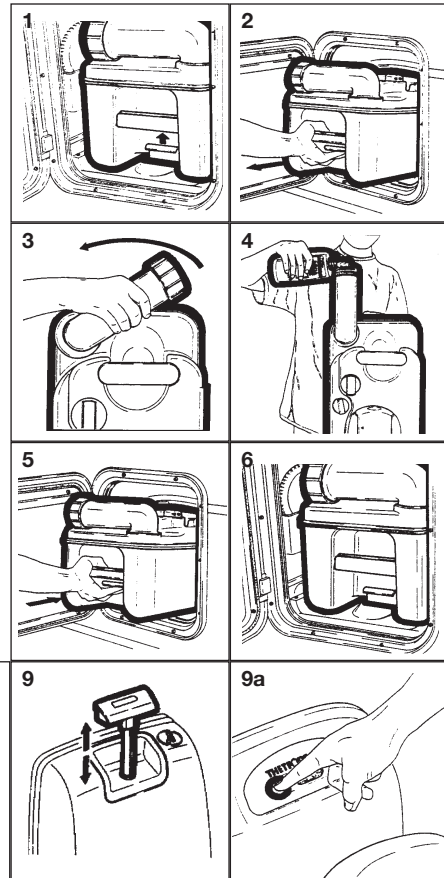

Fitted Equipment

10. After use open the blade by turning the blade-handle anti-clockwise (fig. 10).
- 10a. C-200 CWE only: After use open the blade by pressing the 'open' button (fig. 10a).
11. C-200 CW only: To flush, lift the flush handle and press it down (fig. 11). After flushing, close the blade by turning the blade handle clockwise.
- 11a. C-200 CWE only: To flush press the flush button (fig. 9a). After flushing, close the blade by pressing the close button on panel (fig. 11a).

The toilet may also be used with the valve blade open, which allows the waste to pass directly into the holding tank.

The waste holding tank is located underneath the toilet and is removed for emptying from the outside of the vehicle through an access door. A rotating pour-out spout, automatic holding tank vent, air release valve, valve blade, carrying handles and hand grip are incorporated in the waste holding tank. A sliding cover guarantees you optimal hygiene.

EMPTYING THE HOLDING TANK

The holding tank capacity is approx. 17 litres and the tank should be emptied when the waste-level indicator lights up. The waste-level indicator lights up when the holding tank contains more than 15 litres of waste.

CAUTION: Do not allow the holding tank to become overfilled. See trouble shooting section for emergency emptying procedure.

12. Open access door and remove the holding tank. The holding tank can only be removed when the valve blade is closed (fig. 12).
13. Carry the holding tank to a normal household type toilet or other authorised disposal point. Place the holding tank in vertical position and rotate pour-out spout upwards (fig. 13).
14. Remove the spout cap. Grasp unit by upper carrying handle nearest to pour-out spout. Place other hand on upper rear hand grip so that vent button can be depressed with the thumb while emptying. This ensures a smooth outflow of the tank contents. (fig. 14).

Note: Only depress the vent button when pour-out spout is pointed downwards.

Rinse the holding tank with clean water. For preparing for use again, see steps 1 to 7.

CLEANING AND MAINTENANCE

The lipseal and the seal of the automatic vent are made of rubber and therefore these parts need regular maintenance (depending on frequency of use, once or twice a month).

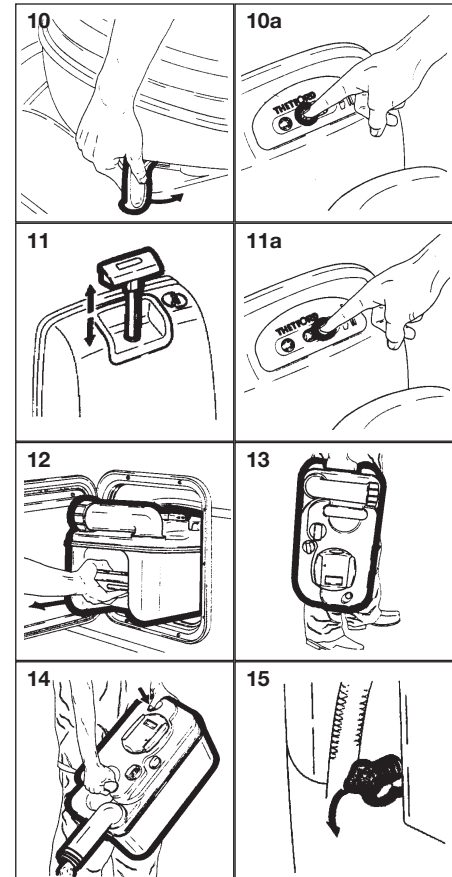

Lipseal: Remove the sliding cover. Open the valve-blade by turning the blade-opener knob anti-clockwise. Clean the seal with water. Dry the seal and grease with silicone spray/oil or vegetable oil.

Seal of automatic vent: Turn the automatic vent 60° anti clockwise and remove gently. Clean the seal with water. Dry the seal and grease with silicone spray/oil or vegetable oil.

To clean the holding tank, empty the tank, and rinse with clean water. Use a mild soap to clean toilet bowl, seat and cover, as well as exterior of toilet unit and holding tank.

NOTE: Do not use strong household detergents or cleaners that contain chlorine, solvents or acid contents.

WINTERING/STORAGE

The Thetford Cassette C-200 CW/CWE is easily winterised for storage.

Empty remaining fresh water into the bowl by activating the flush handle up and down (C-200 CW) or by pressing the flush button (C-200 CWE).

Once pump has been cleared and water flow has stopped completely, release into waste tank. Remove waste tank and empty contents in normal way.

To evacuate any remaining water from the fresh water tank, place a container underneath the drainplug and remove drainplug.

When procedure has been completed replace drainplug and waste holding tank (fig. 15). Clean the seals and grease them after drying (see cleaning and maintenance).

Leave the blade of the holding tank open.

Do not replace cap on the pour out spout, to ventilate the holding tank. (Also grease the seal of the pour out spout cap.)

COLD WEATHER USE

The toilet can be used in cold weather conditions provided that the toilet is in heated surroundings. If this is not the case, you can use a nontoxic antifreeze (propylene glycol) or an antifreeze such as those used in car radiators. Add the antifreeze to the water in the tank. Add the quantity specified in the instructions, paying due regard to the safety instructions.

HIGH ALTITUDE AND WARM WEATHER USE

Pressure may build up in the holding tank if the tank is not inserted while driving at high altitudes or in warm weather conditions. The automatic holding tank vent will vent the tank when there is over- or under-pressure. High temperatures may require additional Thetford toilet fluid.

THETFORD WARRANTY

1. The Thetford Cassette is warranted for one year from the date of purchase, please fill in and return the warranty card.
2. The warranty covers replacement of

defective or flawed parts and the inadequate performance of the toilet.

3. In case of a defect apply to an original dealer or Thetford Service Centre with proof of purchase.
4. Defects, which in our judgement occurred from misuse, negligence or accident, are not covered by the warranty. In addition, the warranty does not apply if the product is installed or handled improperly or if other than the prescribed toilet fluids have been used or if the product has been altered in any way or has been repaired by unqualified persons, or if the serial number and/or date has been altered or removed.
5. Should the original buyer wish to return to us parts believed to be defective, the parts should be sent prepaid. If we find the parts defective and covered by warranty, they will be repaired and returned. If warranty does not apply or has expired, a nominal charge will be made. Any transport costs are for the account of the owner.
6. Before returning product or parts they should be properly cleaned, in order to carry out inspection and repair.
7. No other warranty is given and no personal representative is authorised to make any warranty other than that is contained herein.



Fitted Equipment

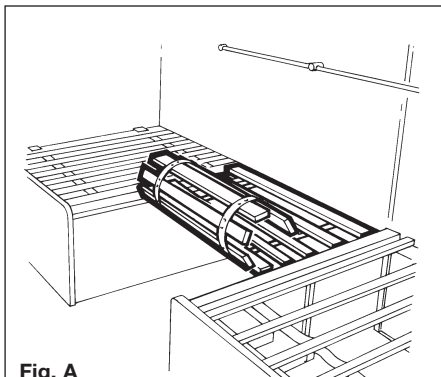

Fig. A

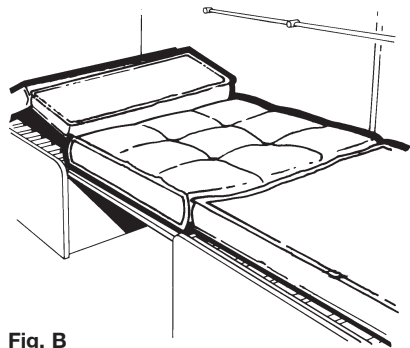

Fig. B

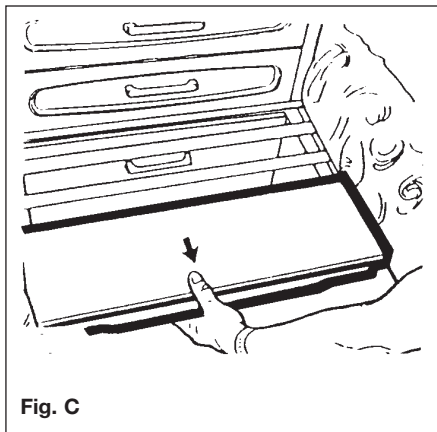

Fig. C

BEDDING

Sleeping bags and continental quilts can be compressed into small spaces and can be ready to use in minutes.

LOWER SINGLE BEDS ASSEMBLY

(Figs. A & B)

1. Unroll bed slat bundle and place between the recess in both seats.
2. Arrange seat cushions as appropriate.

DOUBLE BED ASSEMBLY

(Fig. C)

1. Grip front of slatted bed and walk backwards until bed is fully extended.
2. Arrange seat cushions as appropriate.

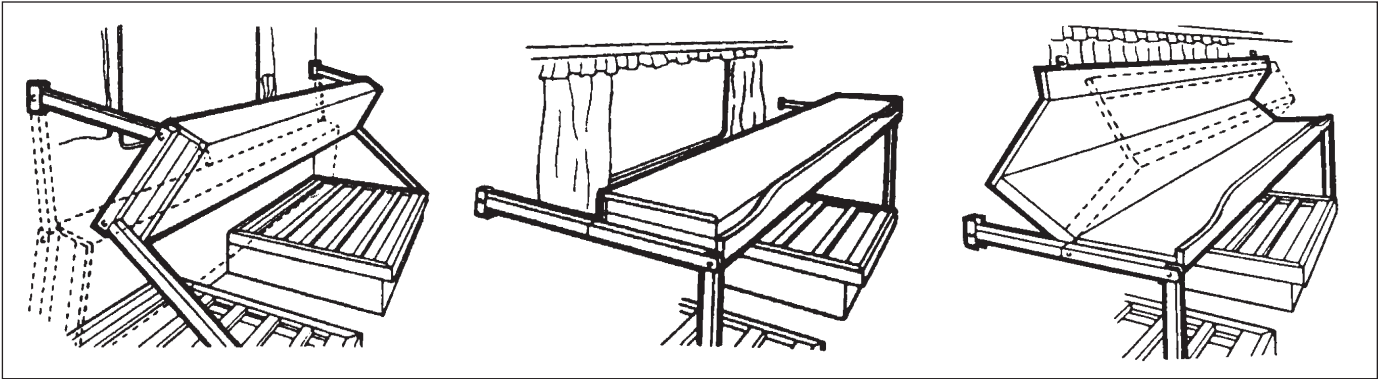

PULLMAN BUNKS

1. Release catches, one at a time.
2. Release press studs on the bed board.
3. Grasp the bunk as shown and pull carefully in direction of arrows.
4. The bunk is designed to automatically move into the correct position.
5. Where a bed board is fitted, unfold and make sure it is secured by press studs when lifted into position. (The bed board is required to protect both the occupant and the window from damage during use of the bunk.)
6. Locate safety boards.
7. Arrange seat cushions as appropriate.

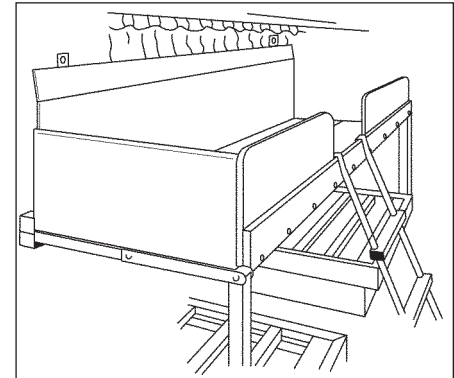

Fitted Equipment

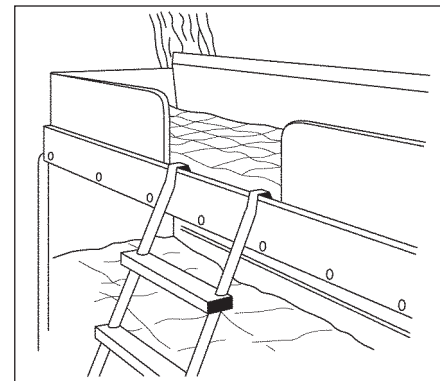
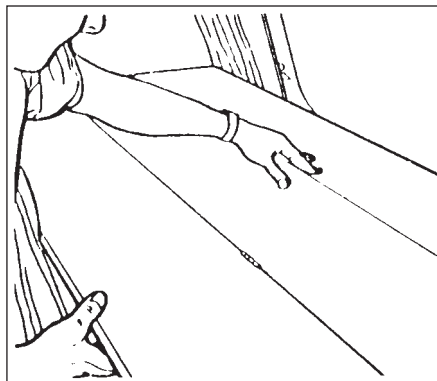
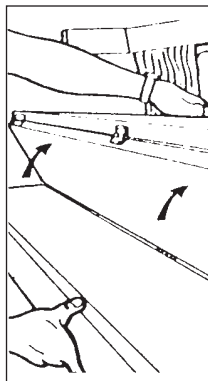
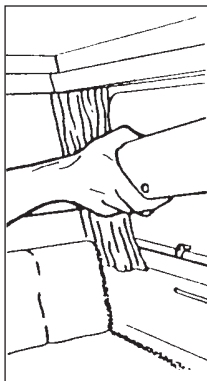

DROP DOWN BUNK

The bunks (if any) fitted to your caravan are guaranteed to a weight limit of 11 stones (70 kg).

1. Remove bunk from its stored position below lockers, taking care to draw out each side equally thus avoiding damage to the caravan walls.
2. Locate on bunk supports and unfold, ensure open bunk is pressed firmly into position and cannot slide out of bunk supports.
3. Locate safety boards.
4. Arrange seat cushions to suit.

On caravans with rear side windows fitted with cassette blinds, care must be taken to avoid damaging the blind frame. Lower the bunk bed (unopened) onto the rearmost section of the bunk support rails, slide the front of the bunk forward whilst at the same time unfolding it.

Ensure that your fingers are clear of the front upstand whilst opening and closing the bunk.

WARNING: Always ensure safety boards are located before entering the bunk.

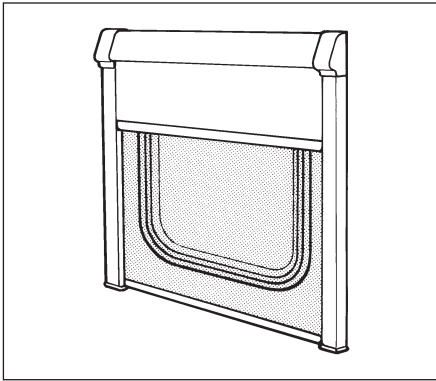

DOUBLE CASSETTE BLINDS (SEITZ)

Blinds and Flyscreens

Flyscreen and blinds operate in the same manner. The flyscreen can only be 'fully up' or 'fully' down, but the blind also has an intermediate position.

To operate, pull down by holding the finger(s), gently ease towards the window to locate the catches. To retract, pull down easing away from the window to release the catches and guide to the required position.

- ONLY OPERATE BY HOLDING THE FINGERGRIP(S) - pulling on one side will cause uneven running and snagging.

- DO NOT ALLOW THE BLIND OR FLYSCREEN TO RE-COIL WITHOUT CONTROL.
- It is not recommended that blinds and/or flyscreens are left in the down position for long periods, or when travelling, as this can result in fatigue of the spring.
- Clean the cassette, side track and fabrics with mild detergent and water.
- Lubrication of mechanism or spring is not required or recommended. However, if components should require cleaning, use only WD40 or similar with fluff-free cloth. Other lubricants may result in damage to fabrics and plastics.

Tension Adjustment

Remove plastic cover (if fitted) to locate tension lugs. The tension lugs have a slot and are located in the cassette on a 'bayonet' principle. Insert screwdriver into slot (ensure a good fit), turn lug clockwise to allow the spring tension to push the lugs just free of the cassette. Keep fingers away from screwdriver tip to avoid accidental injury. Spring can now have more or less tension applied as required.

If in doubt of tension to be applied, release all tension and re-start. In which case, with blind fully wound on the roller, apply 12 revolutions of lug (factory setting).

Refitting is a reversal of removal procedure.

For more detailed information, see manufacturer's instructions.

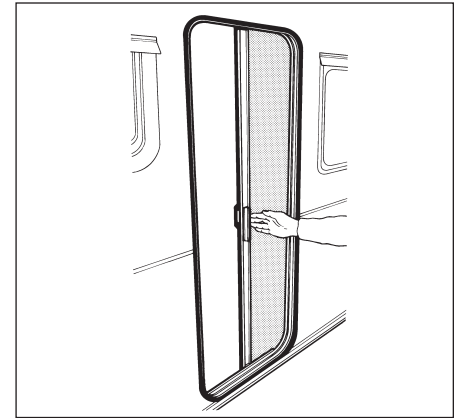

DOORSCREEN

When drawing or releasing the doorscreen, care should be taken not to let it spring back freely, this may result in damage to the screen or its fittings.

Always pull the doorscreen close to the centre. It is not advisable to pull close to the top or bottom as this will cause snagging and uneven running.

Caution

When opening or releasing the doorscreen, care must be taken to avoid trapping fingers.

Do not allow the doorscreen to slam open.



Fitted Equipment

ROOF LIGHTS

When opening the roof lights, care must be taken to release the locking mechanism as the unit is raised.

Roof lights must be fully closed when towing.

Roof lights provide 12,500mm² of fixed ventilation each.

WINDOWS

All opening windows have two catch positions. The first position is for ventilation the second seals the window from ventilation and rain.

HEKI-2 ROOF LIGHT (SEITZ)

The lift/tilt roof light can be set in 3 positions by means of pneumatic springs.

Position 1 lifts the pane 12mm without allowing rain to enter the caravan.

Position 2 sets the pane to a 150mm opening and locks with a bar.

Position 3 opens the pane through 55°.

A fully adjustable flyscreen and black-out screen are built into the inner frame. The flyscreen can be drawn independently and the black-out screen is variable for partial or full black-out.

Forced ventilation functions via a brush lined duct instead of a ventilated pane.

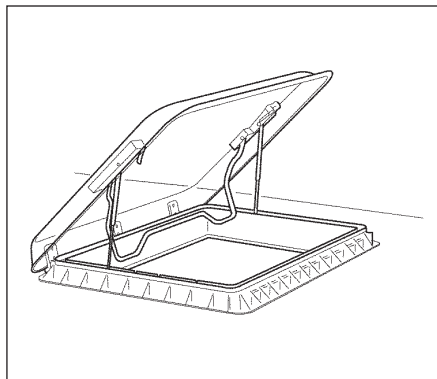

A cover hood can be fitted for winter protection.

Heki-2 roof lights provide 13,200mm² of fixed ventilation

THE OMNIVENT (12V) ROOFLIGHT

The Omnivent is a double glazed rooflight constructed from a synthetic ultra-violet screened material. Its side operating mechanism allows a completely free central opening with built-in fixed ventilation when closed.

Red Switch = Mode of Operation

Induction (IN)

Expel (OUT)

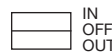

Black Switch = Speed Control

1, 2 and 3

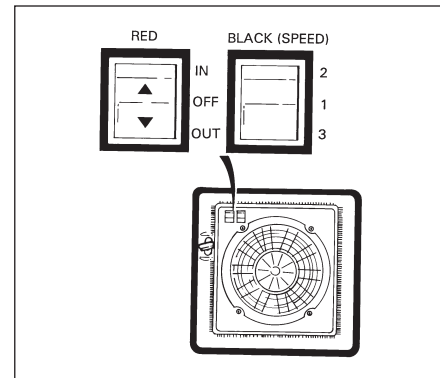

Omnivents give no fixed ventilation when set on induction.

AIR CONDITIONER (BLIZZARD 1500)











The Electrolux air conditioner is optional and replaces rooflights or Omnivents.

Fitted Equipment

THE BLIZZARD 1500 AIR CONDITIONER

WARNING: Never introduce your hands or other object within the air inlet openings.

Starting and function selection

	Main Switch	ON-OFF	Position  air conditioner ON Position  air conditioner OFF
	Warm/Cold Dual Switch	Warm-Cold	Position  fresh air Position  warm air
	Thermostat	Air Temperature (18°C-40°C)	By rotating the knob clockwise, temperature increases (max 40°C) By rotating the knob anti-clockwise, temperature reduces (min 18°C)
	Fan Switch	Air Speed	Position  high speed Position  low speed

Maintenance

To ensure trouble free running it is recommended that the unit be cleaned once or twice a year.

Never attempt the following until the power is disconnected and the unit is cool

Remove dust and dirt with a damp cloth (do not use petrol or solvents).

Check that water trap holes are not clogged.

Periodically open cover and clean filters by washing with a mild detergent solution and allow to dry before refitting.

The Blizzard air conditioning unit provides no fixed ventilation.

ASH FRAMED DOORS

In order to provide customers with the latest designs of door furniture it is possible, due to the use of natural wood, that warping may occur. This should not detract from the correct functioning of items fitted in the caravan.

SHOWER

When using the shower, always ensure that the shower curtain is fully drawn thus avoiding water spray on unprotected areas.

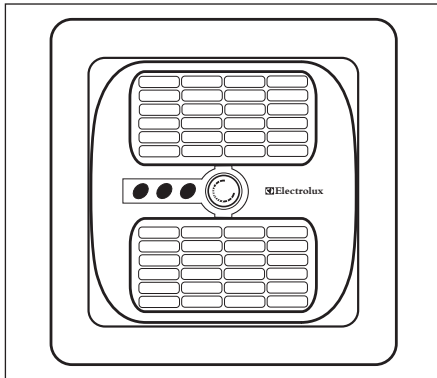

To set the required temperature adjust the RED/BLUE selector control knob against the indicator mark on the outer bezel. Airflow direction can be achieved fore and aft by adjustment of the air outlet louvres.

Attention

Never obstruct the air inlets and outlets

The air conditioning compressor runs during the refrigerating phase, if switched on and off at once it may get damaged. Therefore, it is very important to wait at least 3 minutes before attempting to switch it on again.



Fitted Equipment

TABLES

Slide top of drawers out and fold back to form convenient table. (Fig. A)

The pedestal table can be swung round for easy access to the seating and then re-positioned afterwards. (Fig. B)

Tables stored in the table storage compartment must be securely clipped into place whilst in transit.

CAUTION

When erecting the free standing table, be careful to avoid trapping fingers.

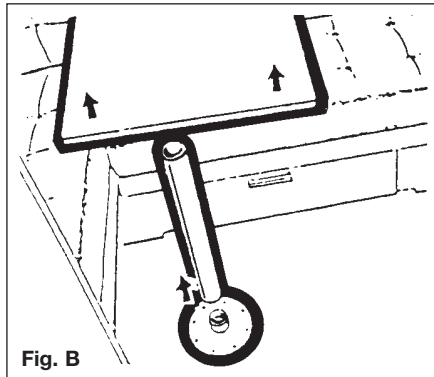
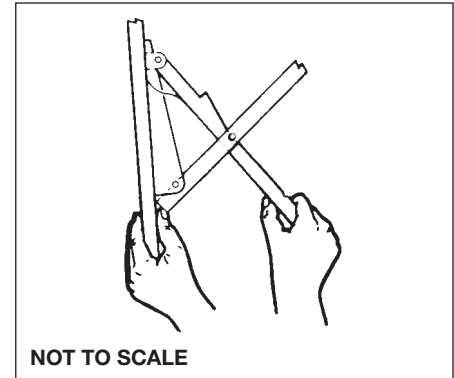
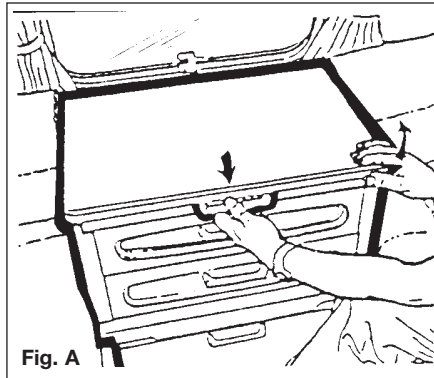

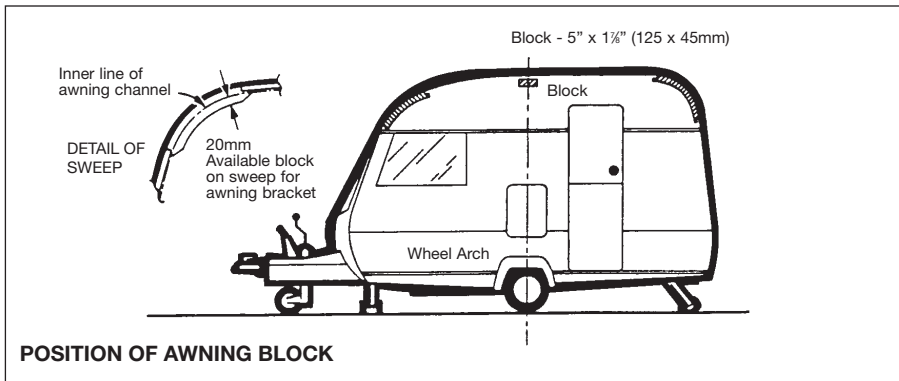

FIXING OF AWNINGS

In order to avoid puncturing the outer skin of the caravan wall, it is recommended that awning poles are fixed to your caravan using load spreading eyelet pads or rubber sucker pads.

Attaching awning brackets and associated fixings to your caravan by using mechanical methods which pierce the outer skin of the caravan wall can allow water ingress which will invalidate the product warranty.

Important:

Care must be taken when using an awning as poles and suckers can cause damage to exterior side panels.

Note:

Awnings should be kept ventilated when discharging products of combustion exhaust into them.





MAINTENANCE

Modifications	98
Caravan Exterior	98
Caravan Interior	98
Winterisation/Storage	99
Alko Running Gear	101
Operation and Maintenance	101
General Maintenance	104
Brake Drum/Hub Assembly	104
Couplings	104
Towing Ball	105
Over-running Device	105
Jockey Wheel	105
Brake Linkage	105
Corner Steadies	105
Braking System	105
Tyre Wear and Damage	105
Wheels	105
Al-Ko and Vario Galvanised Chassis	106
Shock Absorbers	106



Maintenance

MODIFICATIONS - DIY WORK

Owners need to be aware that carrying out DIY modifications to your caravan may in certain instances, invalidate the warranty cover and could also affect the safety and structure of the caravan.

Before carrying out any DIY work within the warranty period (3/5) years please check with your nearest Swift Group dealer or contact Supercare customer services on 01482 875740 for advice.

CARAVAN EXTERIOR

Aluminium Panels

The stove enamelled paintwork is very durable and easy to clean owing to the high gloss properties.

Plastic Panels (GRP/ABS)

These are used for front and rear panels and, in some cases, for roof and side panels.

Cleaning

For both aluminium panels and plastic panels.

1. Wash the caravan regularly with mild detergent. Rinse with cold water and leather off.
2. For better protection a similar coloured good quality car wax may be applied.

When cleaning Sikaflex sealed areas, use Domestos/water.

WARNING: Under no circumstances use any abrasive cleaning agents or solvents on the exterior panels.

Care should be taken as the silicon in some polishes can attack the rubber used on the exterior for seals and gaskets.

Mouldings

All mouldings are of anodised aluminium and will retain their lustre for a long period if no abrasive materials are used to clean them.

Acrylic Windows

The windows in your caravan are fully double glazed and with care will remain sparkling and scratch-free.

Cleaning: Wash down as you would your car. Do not use a sponge on dirty windows.

When all dirt has been removed, dry with a leather or 'Vyleda' type cloth, the catches and stays do not require lubricating.

Keeping your acrylic windows sparkling:

Removing Tar

Use 'Jove Tar Remover' on our double glazed windows, it is obtainable from most leading car accessory or Do-It-Yourself shops. Do not use petrol or other chemicals.

Condensation

As your caravan is double glazed you may occasionally get condensation inside the double glazing. This is particularly so in

severe weather change (usually spring and autumn) and is easily cured in dry weather.

- i) Remove the plastic plugs from interior top of each window.
- ii) Leave unplugged for approximately 1-4 hours until condensation has cleared.

WARNING: Do not wash your caravan with a high pressure washer as these can permanently damage the seals of your caravan.

CARAVAN INTERIOR

Follow these guidelines to ensure your investment is receiving the very best attention.

Side Walls, Roof Lining

A simple wipe over with a damp cloth and a very mild detergent is all that is needed.

Soft Furnishings

Should be vacuumed occasionally to remove grit and sand and help to keep its smart appearance and ensure long life. The upholstery can be cleaned with a mild, reputable upholstery cleaner. It is recommended that the curtains and pelmets are specialist cleaned only. The foam used in cushions is manufactured to meet fire regulations. It requires time to return to its normal position after prolonged use.

Work Surfaces

You should not stand very hot items on any of the work surfaces, especially models with polycarbonate moulded sinks and drainers.

Cupboard Catches

It is advisable to lightly oil all cupboard catches, sliding bolts and hinges from time to time.

Bathroom, Shower Room and Kitchen Equipment

All the Thermoplastic parts in these areas have easy clean surfaces. To ensure long life and prevent damage you must not use any cleaning materials at all and ensure water temperatures do not exceed 70°C, (putting cold water in first is suggested). After every use it is essential that you rinse with clean water only and wipe with a soft damp cloth. Failure to follow these simple instructions may result in premature failure or cracking which will not be covered by any guarantees (including extended warranties).

Furniture

A simple wipe over with a damp cloth should be all that is required. Polishing with a proprietary brand of wax polish enhances and maintains furniture in showroom condition.

It must be remembered that because the frames of the doors are made of ash, which is a natural product, they can be affected by temperature and humidity and may bow under certain conditions. As conditions

change they should revert to their original positions.

WINTERISATION/STORAGE

This is probably an opportune moment to arrange for the caravan to have its annual service at your appointed dealer.

The following applies wherever your caravan is stored particularly during the winter months.

Do not park near trees or larch type fences, due to possible wind damage.

Keep any grass around the floor of the caravan short, to maintain air flow and stop any possible damp getting into the caravan.

It is advised that the caravan is ventilated regularly throughout the winterisation /storage period, opening windows, doors and rooflights when possible.

General

All moving parts should be checked for free operation.

Clean all cooking appliances and refrigerator.

Lubrication should be carried out at the points illustrated in the general notes on chassis maintenance (page 98).

Charge up the on-board battery every 2 months.

Check alarm battery condition every 2 months and charge if necessary.

Leave the refrigerator door open.

Leave furniture doors and lockers open to allow air to circulate fully.

Soft Furnishings

Clean and dust the upholstery and if possible remove before placing the caravan into winter storage. Alternatively, stand the cushions on their edges to allow circulation of air. This will reduce the possibility of dampness from condensation.

Keep curtains or blinds closed, to minimise fading of furniture.

If the blinds and/or flyscreens remain down for a prolonged period of time, re-tensioning of the springs will be necessary before re-use.

Wheels and Tyres

Do not store in one position with partially deflated tyres. The tyre walls will suffer and do present a real danger of blow outs, especially when travelling at faster speeds than are allowed in the UK.

The wheels should be turned every couple of weeks or even better, the wheels removed and the caravan placed on “winter wheels” or axle stands.

If you are removing the wheels, follow the jacking procedure for changing a wheel.



Maintenance

Water System

Ensure water pump is turned off.

Lift kitchen sink unit lid and clip in open position.

All single lever mixer taps, including the shower control, should have the lever moved to the central position and lifted to the open position for hot and cold.

All conventional taps should be opened.

Remove shower head. Let the shower hose drain into the shower tray and then return to holder.

Drain water tanks if fitted:

Internal tanks- open inline valve adjacent to the tank. Valve is open when handle is inline with valve.

External underslung tanks - remove drain pipe from retaining clip and open tap. Allow water to drain. Clip pipe back in position.

Open system drains. Remove red drain plug from under the floor of the vehicle (Fig.1) and place in drawer.

Drain water heater. Open yellow handle on inline valve adjacent to heater. Valve is open when handle is vertical.

Before recommissioning the system reverse all above actions. (See Taps in Services section)

The Thetford Cassette porta potti is easily winterised for storage. Empty the fresh water tank using the drain tube/fresh water tank level indicator (level indicator on electronic

Push up collar (A) to release and pull plug (B) down to remove.

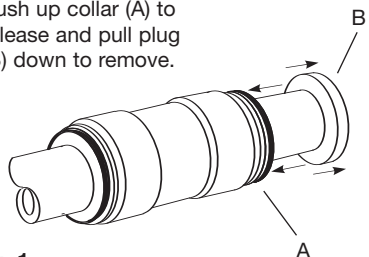

Fig. 1

models only). Pull the lever indicator/drain tube down from top plug position and outward through door opening to drain water from the tank.

Empty the water fill funnel by pulling the bottle away from tank. Remove the small water cap on the filler bottom, allowing water to drain from the water funnel. (Not C-200 toilet).

Do not tighten caps, this helps in keeping unit dry.

The pour out spout and vent plug can be removed. Seals should be greased if necessary with acid-free vaseline.

Recommissioning the Water System

Fill the fresh water tank on the Thetford Cassette porta potti using a hose or jerrycan until the water in the funnel reaches the neck. Tank capacity is 15 litres. Aqua Rinse may be added to improve cleaning of bowl and flushing of unit.

Replace cap. Swing back the water fill funnel until it touches the water tank.

Add Aqua Kem (100 ml) into the Cassette (or 120 ml if using Aqua Kem Bio) through the pour out spout. Add small amount of water through the pour out spout and replace the cap.

It is advisable after storage to flush the water system initially with a sterilising agent (such as Milton), and then with water repeating until the system is well flushed through.

Connect the pump.

Fill the system with water until water flows freely from the hot taps. About 2 gallons of water will be required. Close the hot taps.

Appliances

Before starting caravanning after storage check all gas appliances and electrical points.

Note: Preferably not less than once a year, the electrical installation should be inspected and tested by a qualified electrician.

After storage it is advisable to air the caravan and clean throughout, especially cooking appliances and the refrigerator.

Replace the bedding and wheels if they were removed for storage.

Important

Always follow the manufacturers recommended procedures after use of fitted equipment in the caravan and before storing for any length of time.

ALKO RUNNING GEAR

Coupling Head

The ball couplings are entirely automatic in operation and designed for one hand operation to suit the 50mm international ball recommended by the British Standards Institution, National Caravan Council and the Society of Motor Manufacturers and Traders. Each type has provision for an anti-theft device (available as an extra) consisting of brass insert, complete with 2 keys. The locked button will prevent movement of the handle, therefore making it possible to lock the coupling either “on” or “off” the towing ball.

Operation - Type AK10/2

Lift locking trigger, and lift handle upward and forward. Place the unlocked coupling onto the towing ball and with the slightest downward pressure it will lock onto the ball automatically. Ensure locking trigger returns to its free position before commencing to tow.

Operation - Type AK 13/2

Lift handle upward and forward, this disengages the security tooth. Place the unlocked coupling onto the towing ball and with the slightest downward pressure it will lock onto the ball automatically. The security tooth should again be fully engaged.

Uncoupling

Having lowered the jockey wheel to the ground, operate the handle as previously described. Lift the coupling clear of the towing ball either manually or by operating the telescopic jockey wheel.

IMPORTANT

If the nose of the caravan is lifted manually the locking trigger must be engaged first and the handle lifted forward. Failure to do this will cause the nose-weight to be transmitted through the locking button and damage will occur.

Forward Braking

In the free position, with the handbrake fully forward in the OFF position, the drawshaft of the overrun device is fully extended and the shoes are clear of the drum.

As the towing vehicle brakes, or starts to drive downhill, the drawshaft of the overrun device is depressed toward the unit being towed. This action imparts linear motion to the main shaft of the overrunning device which is transmitted via the overrun lever, brake rod and Bowden cable to the expanding clutch. This mechanism forces the leading brake shoe and, by reaction, the trailing shoe outwards into contact with the drum.

Friction between the brake shoes and the drum creates a tendency for both shoes and

the expanding clutch to move in the direction of forward rotation until they abut against the adjuster box. This ensures that both remain in the braking position.

Reversing

When the towing vehicle reverses, the drawshaft is pushed backward, moving the overrunning device through its full travel. This movement is transmitted in the normal manner to the expanding clutch.

The clutch forces both shoes into contact with the drum. Initial friction between these creates a tendency for the shoes and expanding clutch to move in the direction of wheel rotation i.e. reverse. This movement imparts pressure to the spring-loaded auto-reverse lever, causing it to collapse. Thus, friction between the shoes and drum is almost eliminated, allowing the trailer to reverse as one with the towing vehicle.

Slight forward movement of the chassis will allow the coil spring to reassert itself, enabling the reverse lever to recover to its normal position. Normal braking is then immediately available.

Parking

The AL-KO parking brake system incorporates a patented device for added safety when parking on a reverse-sloping site or steep hill.



Maintenance

The AL-KO parking brake system comprises a handbrake lever mechanism actuating a Bowden cable which operates a brake unit assembly contained within the wheel hub.

AL-KO provide two types of parking brake system on their trailers, with the Bowden cable and the wheel hub brake unit being common to both types.

The difference between the systems is the handbrake mechanism used to actuate the Bowden cable.

AL-KO's unique parking brake system requires a source of stored energy to lock the wheel brakes should the trailer start to move after it has been uncoupled from the towing unit.

This energy source can be provided by either a spring cylinder charged by hand or by a gas filled cylinder acting as an energy store.

Each system requires a slightly different method of operation when parking the trailer, though they both operate in the same manner when forward or reverse braking is applied.

Spring Cylinder Type

A spring system is attached to the link between the handbrake lever and the central brake rod. Full application of the handbrake lever (such that the lever is vertical) to the last tooth of the ratchet compresses a steel spring inside the steel cylinder and energy is stored.

The action of the brake lever imparts motion to the brake rod, the Bowden cable and the expanding clutch. This mechanism forces both shoes into contact with the drum.

At this stage, the brake unit is latent, the mechanism waiting to see in which direction the trailer will start to move.

If the trailer starts to move backwards, the stored energy in the spring will be released. The trailing brake shoe and by reaction, the leading shoe together with the expanding clutch will tend to move in the direction of rotation (reverse) and abut against the stop. Thus the trailer is braked.

However, if the handbrake is NOT fully applied to the last tooth (i.e. vertical) and is set to some lesser position than the full vertical, then problems will almost certainly arise after the trailer has been uncoupled from the towing unit.

If the trailer is parked on a reverse slope or if it is pushed backwards, then the brake mechanism will act as though the trailer is being reversed by the towing unit. The shoes and expanding clutch will tend to move with the direction of rotation (reverse) which imparts pressure to the spring-loaded reverse lever, causing it to collapse. Thus, friction between the shoes and the drum is almost eliminated and the trailer will run away.

Operating the Handbrake

Some people may find it difficult to set the handbrake lever to its full vertical position without a great deal of physical effort.

However, AL-KO have designed their system so that the average user need not do so.

For successful parking on a reverse slope or steep hill, the operator need only apply the handbrake with one hand while gently but purposefully inching the caravan trailer a small distance backwards with the other.

The user must supply this small but essential backward movement to ensure that the fulcrum of the transmission lever moves past the point of reverse, thus preventing the lever from collapsing as it would normally do when reversing.

Most users will find it easier to stand facing the towing unit while applying the hand brake and at the same time gently push the caravan an inch or two backwards with their posterior.

Gas Cylinder Type

A gas cylinder, acting as an accumulator of stored energy, can be fitted to the handbrake lever to provide the same effect as a spring cylinder.

This system is much more user friendly, as the handbrake lever need only be applied until it passes a clearly detectable dead point for it to render parking on reverse slopes or steep hills absolutely safe.

It takes minimal effort from the operator to move the handbrake lever past this dead point.

If the caravan or trailer starts to move when uncoupled from the towing unit, then the energy stored in the cylinder is released and the brakes applied in the normal manner.

Important Points to Remember

It is absolutely vital that the slight backwards push of the caravan or trailer is applied before it is uncoupled from the towing unit.

It is also important to check that the brake has in fact operated correctly as soon as the caravan has been uncoupled.

If the caravan or trailer is to be parked on a steep slope or on loose or slippery surfaces, it is advisable to chock the wheels.

Where possible, always ensure that the handbrake lever is in the fully vertical position.

When the handbrake has been applied, it is possible for the caravan or trailer to roll back as much as 25cm before the full force of the brake takes effect.

All components of both the overrun device and the wheel brakes must be those manufactured by AL-KO as the braking and reversing systems must be matched to ensure optimum braking performance.

Combining parts manufactured by AL-KO with those produced by other suppliers will invalidate any guarantee entered into by AL-KO.

Recommended Brake Adjustment Procedure

Jack up the axle raising the road wheels clear off the ground. Ensure drawshaft is fully extended (in the towing position) and the handbrake is in the "OFF" position (fully forward).

Check that there is some end float in the rod and spring cylinder.

Adjust brakes first (Fig. A) and the linkage only if necessary.

IMPORTANT: During Wheel brake adjustment the drum must only be revolved in the direction of FORWARD rotation. Do not use excessive force during adjustment.

Wheel brake adjustment is effected through a hole in the brake backplate (see Fig. A). With a screwdriver adjust the starwheel in the direction of the arrow until there is resistance to wheel movement. Slacken until the brake drum turns freely in the forward direction. A check for correct adjustment can

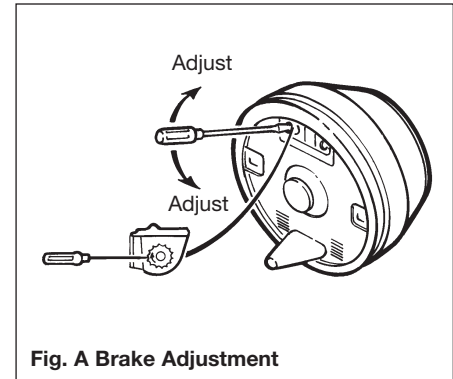
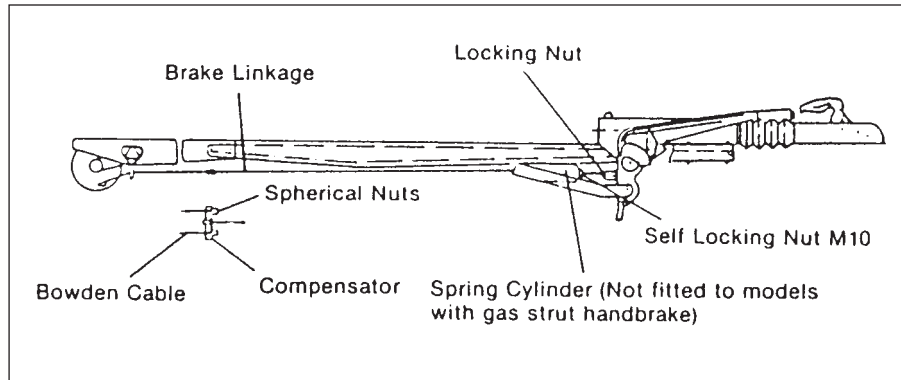

Fig. A Brake Adjustment

be made at the chassis end of the bowden cable. When pulled the cable should extend between 5 and 8mm.

Apply the handbrake two or three times to ensure brake shoes are centralised in the drum. Re-check the shoe clearance at the wheel brake.





GENERAL NOTES ON MAINTENANCE

1. Brake Drum/Hub Assembly

The EURO AXLE fitted to your caravan comes complete with maintenance-free wheel bearings GREASED AND SERVICED FOR LIFE. Adjustment is not required during the design life of the sealed bearing (100,000 km).

WARNING: If replacement of the brake drum or shoes is required, this must be carried out by authorised AL-KO Service Centres.

Centre brake rod. Check full thread engagement in the fork end of the overrunning device. Secure locking nut.

At the axle ensure compensator plate is parallel to the axle by setting the adjuster nuts on the bowden cables. Secure lock nuts.

Adjust centre brake rod at the rear nut so there is no clearance between the overrun lever and the drawshaft and plate. Secure lock nuts.

Correct adjustment of the linkage can be checked by engaging handbrake lever on the second tooth of the ratchet segment. In this position you should feel a slight braking force at the wheels.

Finally screw up the self locking nut to give 1mm clearance between the nut and the spring cylinder.

Note: Reversing will be difficult if either wheel brake or brake linkage is overadjusted.

If the warning is not observed:

- the warranty is void and
- the wheel may become detached.

Any attempt to slacken the nuts on the stub axle will result in the toe-in being adjusted.

This will cause:

- Loss of guarantee
- Bad towing performance
- Increased tyre wear

2. Couplings

1. Clean and grease spherical seat, bearing parts and pivot pins regularly.
2. Thoroughly examine all moving parts for wear and correct functioning.
3. Couplings should never be drilled.

3. Towing Ball

The automobile towing ball should measure 50mm maximum and 49.5mm minimum (DIN 74058). If the ball is found to be worn it should be replaced immediately.

4. Overrunning Device

The device housing is packed with grease on assembly, but will require periodic maintenance to ensure smooth operation of the braking system.

1. Regrease the shaft bearings via the grease nipples provided at 3000 mile intervals, and before storage.
2. Ensure correct functioning of all pivot pins and levers and oil regularly.
3. Ensure correct functioning of handbrake ratchet and oil regularly.

5. Jockey Wheel

Lubricate wheel and screw thread periodically.

6. Brake Linkage

All moving parts should be lubricated periodically to ensure their satisfactory operation.

It is recommended that all brake linkage threads are liberally smeared with grease for protection and as an aid to future adjustment of the system.

7. Corner Steadies

The screw and pivot pins should be lubricated periodically to ensure their satisfactory operation.

8. Braking System

At 500 miles then every 3000 miles or 1 year check and adjust brake linkage to compensate for any stretch of the bowden cables.

Check and adjust wheel brakes to compensate for wear.

IMPORTANT

When replacing the wheels you should tighten the nuts in rotation diagonally, taking care to tighten them equally.

The recommended torque for steel wheels is 88Nm (65 lb/ft) and for alloy wheels 115Nm (85 lb/ft).

CHECK THE WHEEL NUTS BEFORE STARTING EVERY JOURNEY.

TYRE WEAR AND DAMAGE

The legal requirement for tread depth on motor vehicles also apply to caravans.

In order to equalise wear it is suggested that the wheels be balanced and changed around from time to time.

It is dangerous to neglect tyre damage and should you detect a blister, a rupture or a cut which exposes the casing or if it has suffered a violent impact (for example against a kerb) such that there is a risk of internal damage, it is advisable to have it examined by a tyre specialist as soon as possible (as this can affect tracking).

Tyres should be inspected regularly and if any signs of visible deterioration (sidewall cracking, delamination of tread, etc) are evident, they should be replaced regardless of there being a legal minimum tread depth.

WHEELS

The condition of the wheels should be checked regularly, particularly for distortion of flanges and the wheel dish. Wheels which are damaged or distorted, or having wheel stud seatings cracked or deformed, must not be repaired.



Lubrication points are same for all chassis

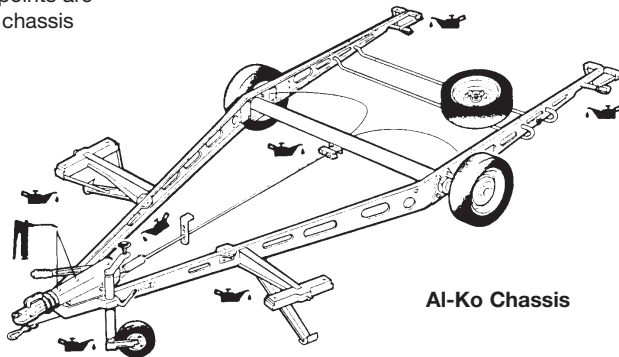

Al-Ko Chassis

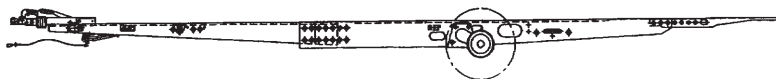

Vario Chassis

ALKO AND VARIO GALVANISED CHASSIS

Hot dip galvanising offers high corrosion protection by forming a barrier layer through reaction with the atmosphere. This will be apparent by the chassis members changing to a light grey colour. During winter periods or storage where there is insufficient air circulation or heavy moisture, a soft porous, light grey oxidation layer may form. This is known as 'White Rust' and should NOT be confused with rust. As applied to steel these deposits should be removed by use of a wire or hard nylon brush.

SHOCK ABSORBERS (OPTIONAL)

The Euro Axle fitted to the caravan is capable of being equipped with octagon shock absorbers specially developed by AL-KO to ensure optimum roadholding of your caravan. They are designed to reduce even the slightest suspension rebound and make towing safer and more comfortable.



GENERAL DATA

Fault Finding	108
Water	108
Gas	110
Cassette Toilet	111
Useful Information	112
Owners Club	112
Spares and After Sales	112
Repair Facilities	112
Factory Tours	112
Caravan Clubs.....	113
Motoring Associations	113
Trade Association.....	113
CRIS	113



Fault Finding

WATER

Problem	Possible Cause	Remedy
Water not flowing from any tap when operated but pump runs	<p>Freshwater tank empty</p> <p>Pump wired in reverse</p> <p>Pump not primed</p> <p>Pipe inlet or outlet pipe disconnected</p> <p>Pump pipes restricted by kinking</p> <p>Blockage in pump inlet or outlet pipe</p> <p>Blocked in-line filter of pump filter</p> <p>Air leak in suction line to pump</p>	<p>Check</p> <p>Check wiring, refer to pump manufacturers instructions</p> <p>Refer to pump manufacturers instructions</p> <p>Check connections</p> <p>Check pipes run</p> <p>Check, starting inside freshwater tank</p> <p>Dismantle and clean</p> <p>Check for bubbles & secure with clip</p>
Pump does not run	<p>Pump or tap incorrectly wired</p> <p>Pump fuse blown</p> <p>Battery disconnected</p> <p>Pump seized or overheated</p> <p>Pressure pump sensing switch may have failed</p> <p>Contacts may be faulty</p> <p>Wiring connections may be faulty</p> <p>On switched tap version, microswitch could be faulty</p>	<p>Refer to pump/tap manufacturers instructions</p> <p>Check wiring connection and then replace with fuse of correct rating</p> <p>Check connections</p> <p>Refer to pump manufacturers servicing instructions</p> <p>Refer to pump manufacturers servicing instructions</p> <p>Check contacts in plug and socket are clean and making contact</p> <p>Check wiring connections</p> <p>Disconnect wires from microswitch and join together. If the pump operates, microswitch should be replaced</p>
Water flows from cold tap but not from hot	<p>Feed pipe to water heater incorrectly connected to the heater outlet</p> <p>Blockage in hot pipeline</p> <p>Heater inlet or outlet pipes kinked preventing flow</p> <p>Hot tap not connected</p> <p>Hot tap failed or blocked</p> <p>Heater non-return valve jammed</p>	<p>Refer to installation instructions</p> <p>Disconnect pipes and inspect</p> <p>Check and re-route if necessary. Ensure that hose is Carver recommended type</p> <p>Refer to installation manual</p> <p>Disconnect and inspect</p> <p>Seek service attention</p>

WATER (continued)

Problem	Possible Cause	Remedy
Water flows from hot tap but has reduced flow from cold	<p>Cold water pipe kinked preventing flow</p> <p>Blockage in cold pipe line</p> <p>Cold tap not connected</p> <p>Cold tap failed or blocked</p> <p>If a water filter is fitted, the cartridge is exhausted</p>	<p>Check and re-route if necessary</p> <p>Disconnect pipes after 1st Y connector and check up to tap</p> <p>Refer to installation instructions</p> <p>Disconnect and inspect</p> <p>Replace cartridge</p>
Reduced flow from both hot and cold taps	<p>Battery condition low causing pump to run slowly</p> <p>If new taps have been fitted they may be restricting flow</p> <p>Pump needs servicing</p> <p>Partially blocked pump filter or in-line filter, if fitted</p> <p>Pump outlet pipe kinked restricting flow</p> <p>Water leak</p>	<p>Check battery state of charge, refer to electrical supply note</p> <p>Disconnect and check that they have at least 1/4" (6.3mm) bore</p> <p>Refer to pump servicing instructions</p> <p>Dismantle and clean if necessary</p> <p>Check and re-route if necessary</p> <p>Check all water connections</p>
Reduced flow from either tap	<p>Y' connector(s) fitted incorrectly</p> <p>Pipe kinking restricting flow</p> <p>Bore size difference in taps</p>	<p>Refer to installation instructions</p> <p>Check and re-route if necessary</p> <p>Use taps of equal bore size</p>
Warm water flows out of cold tap	<p>Hot water back-feeding into cold line, usually if mixer tap or single outlet hot and cold taps being used</p>	<p>Fit non-return valve in cold supply, near tap</p>
If pump motor runs steadily and will not stop	<p>Battery voltage may be too low (below 10.5 volts)</p>	<p>Check that there is water in the container</p> <p>Adjust switch and/or re-charge battery</p> <p>Check all connections in pipework</p>



Fault Finding

GAS

Problem	Possible Cause	Remedy
Hob does not light	No gas Air in pipe	Check level of gas in bottle Check gas bottle valve is on Check gas taps are on Purge system Refer to hob manufacturers instructions
Oven does not light	No gas Air in pipe	Check level of gas in bottle Check gas bottle valve is on Check gas taps are on Purge system Refer to oven manufacturers instructions
Space heater or central heating	No gas Over gassed Air in pipe	Check level of gas in bottle Check gas bottle valve is on Check gas taps are on Check exhaust outlet is clear Turn off appliance, wait 2 minutes and try again Purge system Refer to space heater or central heating boiler manufacturers instructions
Fridge does not light	No gas Air in pipe	Check level of gas in bottle Check gas bottle valve is on Check gas taps are on Purge system Refer to fridge manufacturers instructions
Water heater does not light	No gas Air in pipe	Check level of gas in bottle Check gas bottle valve is on Check gas taps are on Purge system Refer to water heater manufacturers instructions

CASSETTE TOILET

Problem	Remedy
<p>Bowl does not drain when toilet is flushed.</p> <p>Cassette is overfilled</p>	<p>DO NOT REMOVE CASSETTE. While inside the caravan turn flush knob anti-clockwise to open valve blade and leave it in the open position.</p> <p>Open access door on side of caravan. Rotate pour-out spout outward. Place appropriate size container under spout cap. Remove cap carefully. Allow bowl contents to drain into container. This will lower the water level in the bowl. Replace cap and return pour-out spout to stored position. DO NOT REMOVE CASSETTE.</p> <p>Go inside the caravan and turn the flush knob clockwise to close valve blade. Now, the cassette may be removed following the normal removal and emptying procedure.</p>
Odours	Use proper amount of holding tank deodourant specified on bottle.
Toilet tissue does not fit into compartment.	Since some tissues are supplied on larger rolls, it may be necessary to use some tissue before storing into compartment.
Soiled bowl after flushing	Partially fill bowl to cover soiled portion of bowl. Next flush will dissolve waste. Tip: Leave valve blade open during use.
No power to add water to toilet bowl	<p>Check cassette safety sensor switch and fuse-holder for proper engagement and operation.</p> <p>Note: Cassette has to be removed to reach switch and fuse.</p> <p>Insert cassette and try adding water to toilet bowl.</p> <p>Toilet can be flushed manually. Add water. Add water to bowl from a separate container. Turn flush knob anti-clockwise to open valve blade. Turn clockwise to close valve blade.</p>
Cassette cannot be removed	<p>Check for obstacles under retaining clip. Depress retaining clip several times to check operation. Remove cassette.</p> <p>Flush knob and valve blade in partial open position. Close valve blade by moving knob clockwise.</p> <p>CAUTION: If valve blade is open during cassette removal, severe damage to system can occur. Never force insertion or removal of the cassette tank.</p>
Valve blade mechanism sticks or is hard to open	Spray light film of silicone on blade.
Major unit malfunction	Contact your original Caravan Dealer.



Useful Information

OWNERS CLUB

The Owners Club is a completely independent organisation run for the benefit of the caravan owners. They have numerous rallies during the year in various parts of the country and every third year there is a 'Works Rally' where owners have the opportunity to visit the factory. Apart from the friendliness and companionship the Club generates it is also actively engaged in charity work for those less fortunate than ourselves. The address of the Secretary of the Owners Club can be obtained from Supercare (SML Ltd), Tel: 01482 875740.

SPARES AND AFTER SALES SUPERCARE (SML LTD)

There are numerous items available from your dealer ranging from door catches through to spare wheels and touch-up paints. Please note that all after sales enquiries must be directed through your supplying dealer. The after sales service at the factory is geared to support our dealer network as is the service provided by appliance manufacturers.

In the interest of safety, replacement parts for an appliance shall conform to the appliance manufacturers specifications and should be fitted by them or their authorised agents.

Note: Please remember to quote chassis

number when ordering any items from your dealer.

Spares and After Sales

Supercare (SML Ltd)
Dunswell Road
Cottingham
East Yorkshire HU16 4JX
Tel: 01482 875740
Fax: 01482 840082

Customer Care

Tel: 01482 875740
Fax: 01482 840861

NOTE:

The times for contacting Customer Care by telephone are:

9am to 4pm Monday to Thursday.
9am to 12.45pm Friday.

Swift Group Website

www.swiftleisure.co.uk

Swift Group E-Mail Enquiry

enquiry@swiftleisure.co.uk

REPAIR FACILITIES

Should you be unfortunate enough to suffer a major accident with your caravan it is comforting to know that we have a completely separate repair shop facility where their fully trained experts will undertake all types of major damage repair work.

Repairs of a minor nature should be referred first to your local dealer.

FACTORY TOURS

The ultra modern Northmoor production complex at the heart of the Group's manufacturing facilities is now open to the public, offering you a unique opportunity to see how the caravans are produced.

The tours operate on a Tuesday and Thursday between the beginning of April and the end of September (excluding factory holidays).

A programme of activities has been created to make the tour an interesting day out. You will be met at the Group's purpose built Learning Centre and shown a short corporate video before being given a slide presentation covering our complete manufacturing process. Professional Tour Guides will then take you and your party around the Northmoor complex which features state of the art technology. Headsets are supplied so that you hear every word your guide says. The tour finishes at the Group's after sales facility which holds parts for caravans up to 20 years old.

Taking part in the tour is by prior booking only and there is a small charge for adults and children over sixteen.

To reserve a place, you can complete the booking form enclosed with your new caravan or alternatively, arrangements can be made through any Dealer.

The enjoyment of caravanning can be greatly enhanced by membership of one or more of the various caravanning, motoring and holiday clubs. Here are some useful addresses:

CARAVAN CLUBS

The Caravan Club,

East Grinstead House,
East Grinstead
West Sussex, RH19 IUA
Tel: 01342 326944

The Camping and Caravanning Club,

Greenfields House,
Westwood Way,
Coventry,
West Midlands.
Tel: 01203 694995

MOTORING ASSOCIATIONS

Automobile Association (AA)

Fanum House,
Basingstoke,
Hants. RG1 2EA
Tel: 0990 448866
www.theaa.co.uk
e-mail: customer.services@theaa.com

RAC Motoring Services

RAC House,
M1 Cross,
Brent Terrace,
London, NW2 1BX
Tel: 0990 722722

Green Flag National Breakdown

PO Box 300,
1, Cote Lane,
Leeds, LS99 2LZ
Tel: 0345 670345

TRADE ASSOCIATION

National Caravan Council

Catherine House,
Victoria Road,
Aldershot,
Hampshire, GU11 1SS
Tel: 01252 318251
www.martex.co.uk/ncc
e-mail: mail@martex.co.uk

CRIS

HPI Equifax

Dolphin House,
New Street,
Salisbury,
Wiltshire SP1 2TB
Tel: 01722 411430/422422

Swift Group Limited
Dunswell Road, Cottingham,
East Yorkshire HU16 4JX
Tel: (01482) 875740
e-mail: enquiry@swiftleisure.co.uk
web site: www.swiftleisure.co.uk

© 2000 SWIFT GROUP LTD



Index

- A** Air Conditioning.....92
 Alarm Module47
 AL-KO
 Braking101
 Chassis106
 Coupling/Uncoupling101
 Maintenance.....104
 Parking101
 Reversing101
 Shock Absorbers106
 Arrival on Site15
 Ash Framed Doors93
 Awnings95
- B** Battery46
 Beds88
 Blinds.....91
 Blizzard Air Conditioner92
 Brake Linkage105
 Braking System105
 Breakaway Cable12
- C** Caravan Clubs113
 Caravan Terms2
 Cassette Toilets81
 Central Heating.....57
 Chassis Number20
 Clubs113
 Corner Steadies10/15/105
 CRIS113
- D** Doorscreen91
 Driving Licence.....4
- E** Electrical Control Module.....44
 Electricity Supply34
 Arrival on Site.....34
 Generator45
 Mains Inlet Cable35
 Overseas Connections.....36
 12V50
 Electrical Supply Module.....43
 Escape Paths19
- F** Factory Tours.....112
 Fault Finding.....106
 Cassette Toilet.....111
- Gas.....110
 Water108
 Fire18
 Fire Extinguisher19
 Flyscreens.....91
 Fumes20
 Fuses (DC)45
 Fuses (road lights)43
- G** Gas Supply31
 Butane33
 Connection34
 Fault Finding110
 Flue Installations34
 Gas Bottles31
 Hoses33
 Precautions33
 Propane.....33
 Regulator32
 Safety Advice33
 Ventilation.....34
 Generator Guidelines.....46
 Glossary and Checklist4
 Grill78
- H** Habitation Relay46
 Handling13
 Heating57
 Heki Rooflight.....92
 Hob.....78
- I** IDM Alarm System.....47
- J** Jacking Points14
 Jockey Wheel105
- L** Levelling.....15
 Loading and Distribution of Weight...7
- M** Maintenance.....97
 Exterior98
 Interior98
 Modifications/DIY98
 Winterisation/Storage.....99
 Mirrors13
 Motoring Associations.....113
 Motorway Driving13
- N** Noseweight.....4
- O** Omnivent Rooflight.....92
 Oven78
 Overseas Electrical Connections36
 Owners Club.....112
- P** Passengers12
 Plugs.....11
 Preparing for the Road.....7
 Loading & Distribution of Weight...7
 Other Considerations.....9
 Pre-load Checklist.....7
 Pre-tow Checklist and
 Hitch Up10
 Stability8
 Towing Vehicle - Rear
 Suspension8
 Power Modular Systems40
 Pulling Off13
- R** Refrigerator69
 RM427069
 RM427170
 RM4501.....71
 RM6270, RM6271 & RM629172
 Use and maintenance73
 Travel Catch76
 Repair Facilities112
 Reversing.....13
 Road Lighting12
 Rooflights92
 Reich 'Kama' Taps.....27
 Reich 'Twist' Taps.....26
- S** Safety17
 Security.....20
 Services.....21
 Electricity.....34
 Gas31
 Water22
 Shock Absorbers.....106
 Shower93
- Smoke Alarm18
 Space Heaters57
 Spares and After Sales.....112
 Speed Limits.....13
 Stability8
 Stopping on a Hill.....14
 Stoves Hobs, Grills and Ovens76
- T** Tables94
 Taps26
 Thermal Insulation34
 Thetford Cassette Porta Potti79
 Thetford Cassette C-200.....81
 Towing Code.....2
 Towing Vehicle Terms3
 Trade Associations113
 Transformer/Charger Unit.....43
 Truma Space Heaters.....57
 Truma Ultrastore54
 Tyres105
- V** Ventilation19
- W** Water
 Heater.....54
 Pumps54
 Tanks and Systems24
 Weights2
 Whale Aqua Source.....25
 Whale 'Elite' Microswitch Taps.....29
 Whale 'Elegance' Microswitch
 Mixer Taps28
 Whale Supersub Systems24
 Whale Watermaster System24
 Wheels105
 Changing.....14
 Rims10
 Torque9/14
 Windows92
 Winter Maintenance
 and Storage99



Quality with Style

SWIFT CARAVANS, DUNSWELL ROAD, COTTINGHAM, EAST YORKSHIRE HU16 4JX. TEL: 01482 875740 FAX: 01482 840082

e-mail: enquiry@supercare.co.uk website: www.swiftcaravans.co.uk

Issued September 2001

1043696