



Bessacarr Owner's
Service Handbook



Caravan Details

IMPORTANT Enter all your caravan details on this page (see specification in rear of this handbook).

Model
Model Year
Chassis Number
Key Number
Hitch/Steady Lock Key Number
Internal Length
Overall Length
Overall Width
Maximum External Height
Mass in Running Order
User Payload
Maximum Technical Permissible Laden Mass
Nose Weight
Awning Size
Tyre Pressures/Size

Supplied and Pre-delivery Inspection by:

Service History

Signed/Dealer

Date



CONTENTS

Annual Service/Inspection Record	2
Warranty.....	5
Specifications.....	6
Wiring Diagrams – Road Lights	7
Wiring Diagrams – Internal Wiring	8
Bulb Replacement	10
Change of Ownership	

TOURING CARAVANS - ANNUAL SERVICE/INSPECTION RECORD

In order to comply with the warranty, you must have your caravan inspected and serviced by an authorised appointed Swift Group Dealer at least once per year.

It is important that the Owner's Handbook is stamped on the appropriate page by the appointed Swift Group Servicing Dealer. Failure to do this will invalidate the warranty and the transfer of the warranty on the change of ownership.

The inspection should take approximately two to four hours and will cover the areas dealt with in the annual service check list. Any areas requiring service and/or maintenance will be highlighted by your dealer and we recommend that you authorise any necessary work to be carried out.

NB. It is essential, to validate the warranty, that an annual inspection be carried out by an appointed Swift Group Dealer covering the items listed.

1. Damp and lamination test.
2. Coupling head and breakaway cable.
3. Jockey wheel.
4. Chassis and chassis to body security.
5. Corner steadies.
6. Folding step (if fitted).
7. Tyres and tyre pressures.
8. Torque wheel nuts.
9. Brake rods and linkages.
10. Hub bearings, brakes and brake shoes.
11. Handbrake operation and performance.
12. Suspension and shock absorbers (if fitted).
13. 12N and 12S 7-pin plugs and cables.
14. Road lights, wiring and reflectors.
15. Internal lights and 12V DC system.
16. Water heater - gas and 240V AC (if fitted).
17. Hob, grill and oven (if fitted).
18. Refrigerator 240V AC, 12V DC and gas.
19. Gas system.
20. Water pump, taps and water system.
21. Mains 240V AC system.
22. Windows and fittings.
23. Smoke alarm and battery.
24. Roof lights.
25. Furniture hinges/stays etc.
26. Exterior locks and hinges.
27. Grab handle security.
28. All internal vents.
29. Oil seals.
30. Blinds and fly screens (if fitted).

ANNUAL SERVICE/INSPECTION RECORD

CARAVAN MODEL _____ YEAR _____

CHASSIS NUMBER _____

<p>1st SERVICE</p> <p>DATE:</p> <p>DEALER'S STAMP</p> <p>We certify that an annual service has been carried out in accordance with the handbook.</p>	<p>2nd SERVICE</p> <p>DATE:</p> <p>DEALER'S STAMP</p> <p>We certify that an annual service has been carried out in accordance with the handbook.</p>
<p>3rd SERVICE</p> <p>DATE:</p> <p>DEALER'S STAMP</p> <p>We certify that an annual service has been carried out in accordance with the handbook.</p>	<p>4th SERVICE</p> <p>DATE:</p> <p>DEALER'S STAMP</p> <p>We certify that an annual service has been carried out in accordance with the handbook.</p>

<p>5th SERVICE</p> <p>DATE:</p> <p>DEALER'S STAMP</p> <p>We certify that an annual service has been carried out in accordance with the handbook.</p>	<p>6th SERVICE</p> <p>DATE:</p> <p>DEALER'S STAMP</p> <p>We certify that an annual service has been carried out in accordance with the handbook.</p>
<p>7th SERVICE</p> <p>DATE:</p> <p>DEALER'S STAMP</p> <p>We certify that an annual service has been carried out in accordance with the handbook.</p>	<p>8th SERVICE</p> <p>DATE:</p> <p>DEALER'S STAMP</p> <p>We certify that an annual service has been carried out in accordance with the handbook.</p>
<p>9th SERVICE</p> <p>DATE:</p> <p>DEALER'S STAMP</p> <p>We certify that an annual service has been carried out in accordance with the handbook.</p>	<p>10th SERVICE</p> <p>DATE:</p> <p>DEALER'S STAMP</p> <p>We certify that an annual service has been carried out in accordance with the handbook.</p>

All the illustrations and descriptive matter in this handbook are intended to give a general idea of the caravan. Changing market and supply situations and our policy of continuous product development may prevent us from maintaining the exact specifications detailed in this handbook. We therefore reserve the right to alter specifications as materials and conditions demand.

Dealers are not agents of Swift Group Limited, the manufacturer of Swift Group Caravans, and have absolutely no authority to bind the manufacturer by any express or implied undertaking or representation.

All caravans have a 12 month warranty from the date of purchase (or hire purchase). This covers faults arising from a manufacturing defect but not those which are a result of normal wear and tear. The manufacturer will honour the warranty for up to 60 days after the end of the 12 months to enable the first chargeable annual service to be carried out and the SuperSure extended warranty (see below) to commence.

The warranty will be invalidated if the caravan has been neglected, misused, modified or used for hire or reward. The caravan will be deemed to have been neglected if it has not been serviced and maintained as stated in this handbook.

Every owner of a new caravan benefits automatically from the SuperSure extended warranty covering the caravan for years 2 and 3 from the date of purchase. The detailed terms of the extended warranty are set out in the separate SuperSure policy document.

Your dealer should register you for cover under the SuperSure extended warranty at the time your new caravan is handed over to you. It is important to check this registration has been completed to confirm that the caravan is registered under the SuperSure Extended Warranty Scheme for years 2 & 3.

The cost of transporting, towing or moving the caravan by any means to or from the place of repair is the responsibility of the owner.

The benefit of this warranty may be transferred to a new owner if the caravan is sold, provided that the caravan has been serviced by an authorised dealer in accordance with the requirements of this handbook, and details of the change of ownership have been supplied to Swift using the change of ownership form set out in this handbook. Failure to notify Swift of a change of ownership within 14 days of such change will invalidate the warranty.

The benefit of the SuperSure extended warranty may be transferred to a new owner if the caravan is sold in accordance with the procedure detailed in the separate SuperSure policy document.

This warranty only applies to caravans purchased in the UK.

The above conditions in no way affect your statutory rights in respect of the caravan.

Specifications

CAMEO RANGE	465SLE	465SL	5006L	525SL	550GL
Berths	2	2	2	3 opt 4	3 opt 4
Internal Length (At bed box height)	4.70m/15'5"	4.70m/15'5"	5.07m/16'8"	5.30m/17'5"	5.85m/19'2"
Overall Width	2.23m/7'4"	2.23m/7'4"	2.23m/7'4"	2.23m/7'4"	2.23m/7'4"
Overall Height (Including TV aerial)	2.71m/8'11"	2.71m/8'11"	2.71m/8'11"	2.71m/8'11"	2.71m/8'11"
Overall Length	6.18m/20'3"	6.18m/20'3"	6.56m/21'6"	6.78m/22'3"	7.33m/24'1"
Mass in Running Order (Inc. 3% tolerance)	1162kg/22.9cwt	1164kg/22.9cwt	1292kg/25.4cwt	1255kg/24.7cwt	1447kg/28.5cwt*
Essential Habitation Equipment Payload	106kg/2.1cwt	106kg/2.1cwt	106kg/2.1cwt	106kg/2.1cwt	106kg/2.1cwt
Personal Effects Payload	104kg/2.0cwt	104kg/2.0cwt	108kg/2.1cwt	130kg/2.6cwt	135kg/2.7cwt
Optional Equipment	43kg/0.8cwt	46kg/0.9cwt	54kg/1.1cwt	59kg/1.2cwt	62kg/1.2cwt
Maximum Technical Permissible Laden Mass (Declared)	1415kg/27.9cwt	1420kg/28.0cwt	1560kg/30.7cwt	1550kg/30.5cwt	1750kg/34.4cwt
Maximum Technical Permissible Laden Mass (Possible)	1500kg/29.6cwt	1500kg/29.6cwt	1600kg/31.5cwt	1550kg/30.5cwt	1800kg/35.4cwt
Awning A/A Dimension	9.03m/29'8"	9.03m/29'8"	9.41m/30'10"	9.63m/31'7"	10.18m/33'5"
Tyre Size	175R14 5stud 99	175R14 5stud 99	155R13 78	175R14 5stud 99	165R13 83T
Tyre Pressure at Declared MTPLM	60 psi	60 psi	32 psi	65 psi	33 psi
Tyre Pressure at Possible MTPLM	60 psi	60 psi	32 psi	65 psi	33 psi
Static Load on Coupling Head	100kg	100kg	100kg	100kg	100kg
Thermal Insulation and Heating Grade	Grade 2	Grade 2	Grade 2	Grade 2	Grade 2
Bed Sizes					
Front Double (Wrap Round)	205cm x 187cm 6'9" x 6'2"	205cm x 187cm 6'9" x 6'2"	205cm x 187cm 6'9" x 6'2"	205cm x 187cm 6'9" x 6'2"	205cm x 187cm 6'9" x 6'2"
or Two Singles	187cm x 66cm 6'2" x 2'2"	187cm x 66cm 6'2" x 2'2"	187cm x 66cm 6'2" x 2'2"	187cm x 66cm 6'2" x 2'2"	187cm x 66cm 6'2" x 2'2"
Side Single	- -	- -	- -	180cm x 66cm 5'11" x 2'2"	180cm x 66cm 5'11" x 2'2"
Optional Bunk	- -	- -	- -	172cm x 58cm 5'8" x 1'11"	172cm x 58cm 5'8" x 1'11"

*Estimated weight

CAMEO RANGE 2000 - ROAD LIGHTS

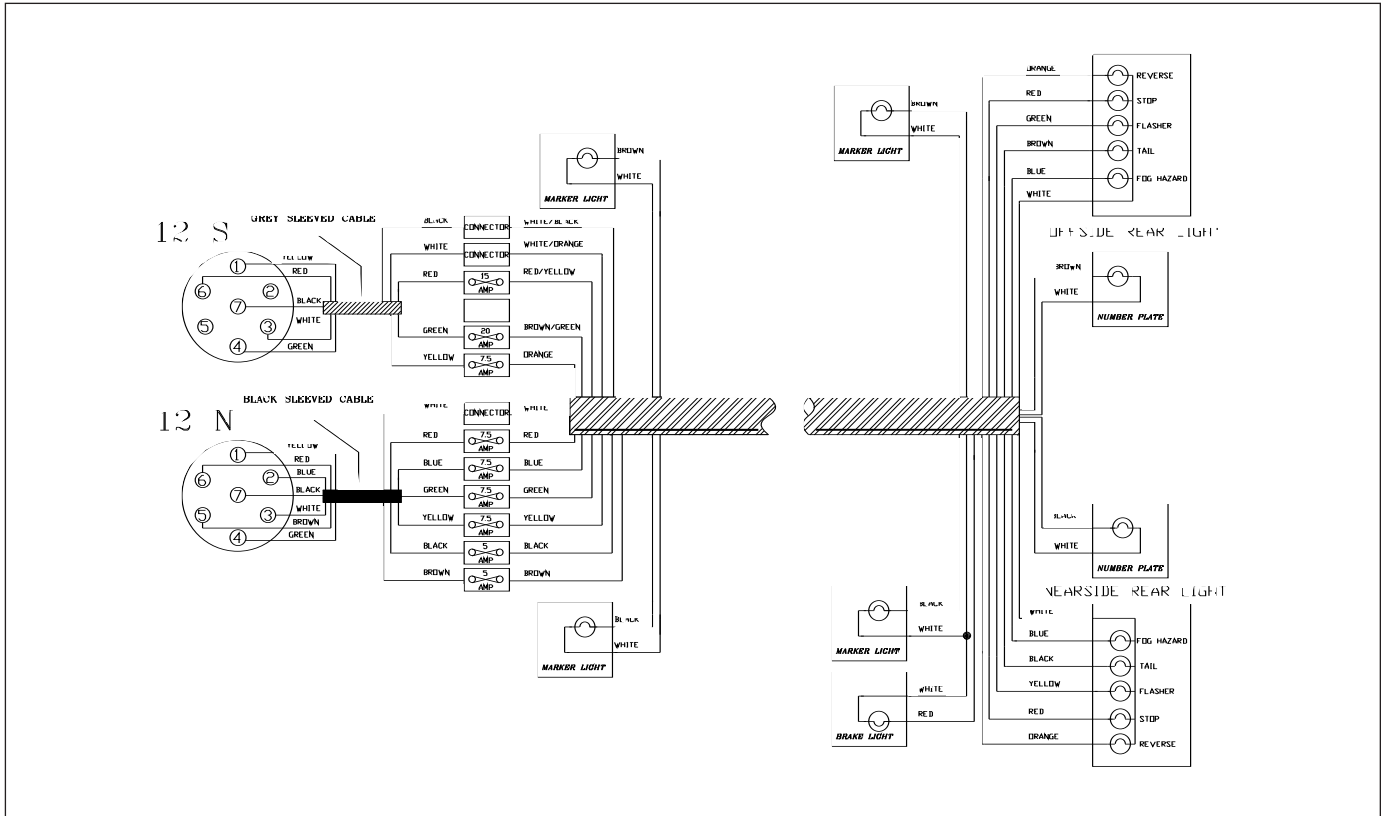

Bulb Replacement

	TYPE	POWER	CAMEO		
ROAD LIGHTS					
Front marker lights	W501	12V 3W	✓		
Side marker	F239	12V 5W	✓		
Reversing light	L382	12V 21W	✓		
Rear indicator light	L382	12V 21W	✓		
Brake light	L382	12V 21W	✓		
Fog/Tail light	L380	12V 21W/5W	✓		
Number plate light	F239	12V 5W	✓		
Hitch cover light	F239	12V 5W	✓		
INTERIOR/OTHER					
Awning	L245	12V 10W	✓		
Double and Single roof	Fluorescent 300mm	12V 8W	✓		
Round ceiling lights	Halogen Capsule	G4 12V 20W	✓		
Round ceiling lights (small)	Halogen Capsule	G4 12V 10W	✓		
Kitchen strip light	Fluorescent 300mm	12V 8W	✓		
Vanity strip light	Fluorescent 300mm	12V 8W	✓		
Vanity down light	Halogen Capsule	G4 12V 5W	✓		
Mains reading	Standard Bayonet	240V 40W	✓		
Doorway Courtesy	Halogen Capsule	G4 12V 10W	✓		
Downlighters	Halogen Capsule	G4 12V 5W	✓		

Note: Not all lights and bulbs feature on all models within a range

NOTIFICATION OF CHANGE OF OWNERSHIP

If you sell your caravan, please notify the change of ownership by completing this page, detaching it and sending it to:
Swift Group Ltd., Dunswell Road, Cottingham, East Yorkshire, HU16 4JX.

DETAILS OF CARAVAN:	Model:	_____
	Chassis No:	_____
CURRENT OWNER:	Name:	_____
	Address:	_____

NEW OWNER:	Name:	_____
	Address:	_____

Please note that the benefit of any unexpired warranty cannot be transferred to the new owner until the change of ownership details above have been received.



INDIVIDUALLY STYLED, BEAUTIFULLY BUILT

Bessacarr Caravans, Dunswell Road, Cottingham, East Yorkshire HU16 4JX.
Tel: 01482 847332 Fax: 01482 840082 e-mail/web site: www.swiftleisure.co.uk

A MEMBER OF THE SWIFT GROUP

Issued September 1999

9830013